



**City of Tacoma**

---

**Environmental Services**

**Stormwater Management Manual  
2016 Edition**

© City of Tacoma  
Environmental Services  
Science and Engineering Division  
326 East D Street  
Tacoma WA 98421-1801

**Notice:**

This manual was developed and written by the Environmental Services Operations and Maintenance Division and Science and Engineering Division staff.

The Stormwater Management Manual is also referred to as the Surface Water Management Manual.

© Copyright 2016 City of Tacoma

All rights reserved. This manual is intended for use by development and redevelopment project proponents, planners and developers, and by City of Tacoma employees and their designees. Any unauthorized use or distribution of this manual or dispersal of its contents is prohibited. This manual may not be reproduced in whole or in part without written permission from the City of Tacoma Environmental Services Department.

---

**Certification Page**

**City of Tacoma Stormwater Management Manual**

I hereby certify that this Stormwater Management Manual was prepared by me or under my direct supervision and that to my knowledge and belief was prepared in accordance with the requirements of Chapter 18.43 RCW. I hereby certify that I am a licensed professional engineer under the laws of the State of Washington. The City of Tacoma does not and will not assume liability for the sufficiency, suitability, or performance of stormwater improvements designed in accordance with this Manual. This Manual is stamped and signed in accordance with Section 196-23-020(1) of the Washington Administrative Code and Section 18.43.070 of the Revised Code of Washington.



# Table of Contents

**Preface . . . . . 25**

## **Volume 1 - Stormwater Site Planning**

**Chapter 1 Development Impacts . . . . . 1-3**

**Chapter 2 Watershed Designations . . . . . 1-5**

- 2.1 City of Tacoma Watersheds . . . . . 1-5
- 2.2 Land Use . . . . . 1-7
  - 2.2.1 Comprehensive Planning . . . . . 1-7
- 2.3 Impaired Water Bodies . . . . . 1-7
- 2.4 Floodplains . . . . . 1-7
- 2.5 Tacoma’s Watersheds and Other Basins – Summary Descriptions . . . . . 1-8
  - 2.5.1 Flett Creek . . . . . 1-8
  - 2.5.2 Leach Creek . . . . . 1-9
  - 2.5.3 Northeast Tacoma . . . . . 1-10
  - 2.5.4 Joe’s Creek . . . . . 1-10
  - 2.5.5 North Tacoma . . . . . 1-10
  - 2.5.6 Thea Foss Waterway . . . . . 1-11
  - 2.5.7 Tideflats . . . . . 1-11
  - 2.5.8 Lower Puyallup . . . . . 1-11
  - 2.5.9 Western Slopes Watershed . . . . . 1-12
  - 2.5.10 South Tacoma Groundwater Protection District . . . . . 1-12
  - 2.5.11 Sensitive Habitat Areas . . . . . 1-13

**Chapter 3 Minimum Requirements for New Development and Redevelopment 1-17**

- 3.1 Overview of the Minimum Requirements . . . . . 1-17
- 3.2 Exemptions . . . . . 1-17
  - 3.2.1 Pavement Maintenance . . . . . 1-18
  - 3.2.2 Underground Utility Projects . . . . . 1-18
  - 3.2.3 Minor Clearing and Grading . . . . . 1-18
  - 3.2.4 Emergencies . . . . . 1-19
- 3.3 Applicability of the Minimum Requirements . . . . . 1-19
  - 3.3.1 New Development . . . . . 1-20
  - 3.3.2 Redevelopment . . . . . 1-20
  - 3.3.3 Equivalent Areas . . . . . 1-21
  - 3.3.4 Cumulative Impact Mitigation Requirement and Vesting . . . . . 1-22
  - 3.3.5 Grade and Fill Projects . . . . . 1-22
  - 3.3.6 Separation of Public and Private Water Quality and Flow Control . . . . . 1-22
  - 3.3.7 Watershed Specific Requirements . . . . . 1-23
  - 3.3.8 Flowcharts . . . . . 1-28
- 3.4 Description of Minimum Requirements . . . . . 1-34
  - 3.4.1 Minimum Requirement #1: Preparation of a Stormwater Site Plan . . . . . 1-34
  - 3.4.2 Minimum Requirement #2: Construction Stormwater Pollution Prevention . . . . . 1-34

3.4.3 Minimum Requirement #3: Source Control of Pollution . . . . .	1-35
3.4.4 Minimum Requirement #4: Preservation of Natural Drainage Systems and Outfalls 1-35	
3.4.5 Minimum Requirement #5: Onsite Stormwater Management . . . . .	1-36
3.4.6 Minimum Requirement #6: Water Quality Treatment . . . . .	1-40
3.4.7 Minimum Requirement #7: Flow Control. . . . .	1-42
3.4.8 Minimum Requirement #8: Wetlands Protection . . . . .	1-45
3.4.9 Minimum Requirement #9: Operation and Maintenance. . . . .	1-46
3.4.10 Minimum Requirement #10: Offsite Analysis and Mitigation. . . . .	1-47
3.5 Exceptions/Adjustments . . . . .	1-50
3.5.1 Exceptions to the Minimum Requirements . . . . .	1-50
3.5.2 Adjustments . . . . .	1-50
3.5.3 Other Exceptions. . . . .	1-51
<b>Chapter 4 Preparation of Stormwater Site Plans . . . . .</b>	<b>1-53</b>
4.1 Stormwater Site Plan Checklist . . . . .	1-53
4.2 Plans Required After Approval . . . . .	1-65
4.2.1 Revisions . . . . .	1-65
4.2.2 Record Drawing Submittal . . . . .	1-66
4.2.3 Engineer's Certification . . . . .	1-66
4.3 Land Use Submittal Requirements. . . . .	1-66
<b>Appendix A Stormwater Site Plan Report Short Form . . . . .</b>	<b>1-69</b>
<b>Appendix B Hydraulic Analysis Worksheet . . . . .</b>	<b>1-79</b>
<b>Appendix C Maintenance Standards for Drainage Facilities . . . . .</b>	<b>1-83</b>
#1 - Maintenance Checklist for Detention Ponds . . . . .	1-85
#2 - Maintenance Checklist for Infiltration Ponds/Basins . . . . .	1-89
#3 - Maintenance Checklist for Infiltration Trenches . . . . .	1-93
#4 - Maintenance Checklist for Closed Detention Systems (Tanks/Vaults) . . . . .	1-95
#5 - Maintenance Checklist for Control Structure/Flow Restrictor . . . . .	1-97
#6 - Maintenance Checklist for Catch Basins/Manholes . . . . .	1-99
#7 - Maintenance Checklist for Debris Barriers (e.g., Trash Racks) . . . . .	1-102
#8 - Maintenance Checklist for Energy Dissipaters . . . . .	1-103
#9 - Maintenance Checklist for Typical Biofiltration Swale . . . . .	1-107
#10 - Maintenance Checklist for Wet Biofiltration Swales . . . . .	1-110
#11 - Maintenance Checklist for Filter Strips . . . . .	1-112
#12 - Maintenance Checklist for Wet Ponds . . . . .	1-114
#13 - Maintenance Checklist for Treatment Wetlands . . . . .	1-117
#14 - Maintenance Checklist for Wet Vaults . . . . .	1-123
#15 - Maintenance Checklist for Sand Filters (above ground/open) . . . . .	1-125
#16 - Maintenance Checklist for Sand Filters (below ground/enclosed) . . . . .	1-127
#17 - Maintenance Checklist for Baffle Oil/Water Separators - American Petroleum Institute (API) Type . . . . .	1-130
#18 - Maintenance Checklist for Coalescing Plate Oil/Water Separators . . . . .	1-132
#19 - Maintenance Checklist for Fencing/Shrubbery Screen/Other Landscaping . . . . .	1-134
#20 - Maintenance Checklist for Gates . . . . .	1-135
#21 - Maintenance Checklist for Grounds (Landscaping) . . . . .	1-136

#22 - Maintenance Checklist for Bioretention Facilities	1-138
#23 - Maintenance Checklist for Rain Gardens	1-157
#24 - Maintenance Checklist for Cisterns	1-163
#25 - Maintenance Checklist for Compost Amended Soil	1-165
#26 - Maintenance Checklist for Vegetated Roof	1-168
#27 - Maintenance Checklist for Pervious Pavement	1-174
#28 - Maintenance Checklist for Ballasted Sidewalk	1-185
#29 - Proprietary Stormwater Devices (Emerging Technologies)	1-186
#30 - General Maintenance Concerns for Stormwater Facilities	1-187
#31 - Maintenance Checklist for Trees	1-189
#32 - Downspout Infiltration Trench or Drywell	1-190
#33 - Downspout Dispersion	1-192
<b>Appendix D Guidelines for Wetlands when Managing Stormwater</b>	<b>1-197</b>

## **Volume 2 - Stormwater Management for Construction Sites**

### **Chapter 1 The 13 Elements of Construction Stormwater Pollution Prevention . 2-3**

<b>Chapter 2 Developing a Construction Stormwater Pollution Prevention Plan (SWPPP)</b>	<b>2-15</b>
2.1 General Requirements and Guidelines	2-15
2.2 BMP Standards and Specifications	2-16
2.3 Step-by-Step Procedure	2-16
2.3.1 Step 1 – Data Collection	2-16
2.3.2 Step 2 – Data Analysis	2-17
2.3.3 Step 3 – Construction SWPPP Development and Analysis	2-18

### **Chapter 3 Standards and Specifications for Best Management Practices (BMPs) . . 2-25**

3.1 Source Control BMPs	2-26
3.1.1 BMP C101: Preserving Natural Vegetation	2-27
3.1.2 BMP C102: Buffer Zone	2-29
3.1.3 BMP C103: High Visibility Fence	2-29
3.1.4 BMP C105: Stabilized Construction Entrance/Exit	2-30
3.1.5 BMP C106: Wheel Wash	2-34
3.1.6 BMP C107: Construction Road/Parking Area Stabilization	2-36
3.1.7 BMP C120: Temporary and Permanent Seeding	2-37
3.1.8 BMP C121: Mulching	2-42
3.1.9 BMP C122: Nets and Blankets	2-46
3.1.10 BMP C123: Plastic Covering	2-51
3.1.11 BMP C124: Sodding	2-53
3.1.12 BMP C125: Compost	2-54
3.1.13 BMP C126: Topsoiling	2-56
3.1.14 BMP C127: Polyacrylamide for Soil Erosion Protection	2-59
3.1.15 BMP C130: Surface Roughening	2-61
3.1.16 BMP C131: Gradient Terraces	2-63
3.1.17 BMP C140: Dust Control	2-65
3.1.18 BMP C150: Materials On Hand	2-66

- 3.1.19 BMP C151: Concrete Handling . . . . . 2-67
- 3.1.20 BMP C152: Sawcutting and Surfacing Pollution Prevention . . . . . 2-69
- 3.1.21 BMP C153: Material Delivery, Storage and Containment . . . . . 2-69
- 3.1.22 BMP C154: Concrete Washout Area . . . . . 2-71
- 3.1.23 BMP C160: Erosion and Sediment Control Lead . . . . . 2-77
- 3.1.24 BMP C161: Payment of Erosion Control Work . . . . . 2-79
- 3.1.25 BMP C162: Scheduling . . . . . 2-79
- 3.2 Runoff, Conveyance and Treatment BMPs . . . . . 2-81
  - 3.2.1 BMP C200: Interceptor Dike and Swale . . . . . 2-82
  - 3.2.2 BMP C201: Grass-Lined Channels . . . . . 2-85
  - 3.2.3 BMP C202: Channel Lining . . . . . 2-89
  - 3.2.4 BMP C203: Water Bars . . . . . 2-90
  - 3.2.5 BMP C204: Pipe Slope Drains . . . . . 2-92
  - 3.2.6 BMP C205: Subsurface Drains . . . . . 2-94
  - 3.2.7 BMP C206: Level Spreader . . . . . 2-97
  - 3.2.8 BMP C207: Check Dams . . . . . 2-99
  - 3.2.9 BMP C208: Triangular Silt Dike (Geotextile-Encased Check Dam) . . . . . 2-102
  - 3.2.10 BMP C209: Outlet Protection . . . . . 2-104
  - 3.2.11 BMP C220: Storm Drain Inlet Protection . . . . . 2-105
  - 3.2.12 BMP C231: Brush Barrier . . . . . 2-115
  - 3.2.13 BMP C232: Gravel Filter Berm . . . . . 2-116
  - 3.2.14 BMP C233: Silt Fence . . . . . 2-117
  - 3.2.15 BMP C234: Vegetated Strip . . . . . 2-124
  - 3.2.16 BMP C235: Wattles . . . . . 2-124
  - 3.2.17 BMP C236: Vegetative Filtration . . . . . 2-127
  - 3.2.18 BMP C240: Sediment Trap . . . . . 2-129
  - 3.2.19 BMP C241: Temporary Sediment Pond . . . . . 2-132
  - 3.2.20 BMP C250: Construction Stormwater Chemical Treatment . . . . . 2-140
  - 3.2.21 BMP C251: Construction Stormwater Filtration . . . . . 2-147
  - 3.2.22 BMP C252: High pH Neutralization using CO<sub>2</sub> . . . . . 2-150
  - 3.2.23 BMP C253: pH Control for High pH Water . . . . . 2-153

- Appendix A Standard Notes for Temporary Erosion and Sedimentation Control Plans . . . . . 2-155**
- Appendix B Construction SWPPP Short Form . . . . . 2-157**

## **Volume 3 - Onsite Stormwater Management, Flow Control & Conveyance**

- Chapter 1 Hydrologic Analysis . . . . . 3-3**
  - 1.1 Minimum Computational Standards . . . . . 3-3
  - 1.2 Western Washington Hydrology Model . . . . . 3-3
  - 1.3 Single-Event Hydrograph Method . . . . . 3-3
    - 1.3.1 Design Storm . . . . . 3-3
    - 1.3.2 Curve Number . . . . . 3-4
  - 1.4 Closed Depression Analysis . . . . . 3-5
  - 1.5 Bypass and Offsite Inflow - Considerations for Flow Control Facilities . . . . . 3-5
    - 1.5.1 Bypass . . . . . 3-5

1.5.2 Offsite Inflow . . . . .	3-5
1.6 Rounding . . . . .	3-6
<b>Chapter 2 Roof Downspout Controls . . . . .</b>	<b>3-9</b>
2.1 Description . . . . .	3-9
2.2 Selection of Roof Downspout Controls . . . . .	3-9
2.3 Roof Downspout Infiltration . . . . .	3-9
2.3.1 Downspout Infiltration Soils Report Requirements . . . . .	3-9
2.3.2 BMP L601: Rain Gardens . . . . .	3-9
2.3.3 BMP L602 Downspout Full Infiltration BMPs . . . . .	3-10
2.4 BMP L603 Downspout Dispersion Systems . . . . .	3-16
2.4.1 Application . . . . .	3-16
2.4.2 Flow Credit for Roof Downspout Dispersion . . . . .	3-16
2.4.3 Roof Downspout Dispersion Setbacks and Site Controls . . . . .	3-17
2.4.4 Infeasibility Criteria for Roof Downspout Dispersion . . . . .	3-17
2.4.5 General Design Criteria for Roof Downspout Dispersion . . . . .	3-18
2.4.6 Maintenance Criteria . . . . .	3-19
2.5 BMP L604: Perforated Stub-Out Connections . . . . .	3-23
2.5.1 Application . . . . .	3-23
2.5.2 Infeasibility Criteria for Perforated Stub-Out Connections . . . . .	3-23
2.5.3 Design Criteria . . . . .	3-24
2.5.4 Flow Credit for Perforated Stubouts . . . . .	3-25
2.5.5 Maintenance Criteria . . . . .	3-25
2.6 BMP L605 Collect and Convey . . . . .	3-25
<b>Chapter 3 Dispersion BMPs . . . . .</b>	<b>3-27</b>
3.1 BMP L611 Concentrated Flow Dispersion . . . . .	3-27
3.1.1 Purpose and Definition . . . . .	3-27
3.1.2 Applications and Limitations . . . . .	3-27
3.1.3 Infeasibility Criteria for Concentrated Flow Dispersion . . . . .	3-27
3.1.4 Design Criteria . . . . .	3-27
3.1.5 Setback Criteria . . . . .	3-27
3.1.6 Flow Credits for Concentrated Flow Dispersion . . . . .	3-28
3.1.7 Maintenance: . . . . .	3-28
3.2 BMP L612 Sheet Flow Dispersion . . . . .	3-29
3.2.1 Purpose and Definition . . . . .	3-29
3.2.2 Applications and Limitations . . . . .	3-29
3.2.3 Infeasibility Criteria for Sheet Flow Dispersion . . . . .	3-29
3.2.4 Design Criteria . . . . .	3-29
3.2.5 Setback Criteria . . . . .	3-30
3.2.6 Flow Credits for Sheet Flow Dispersion . . . . .	3-30
3.2.7 Maintenance Criteria . . . . .	3-30
3.3 BMP L614 Full Dispersion . . . . .	3-31
3.3.1 Purpose and Definition . . . . .	3-31
3.3.2 Applications and Limitations . . . . .	3-31
3.3.3 Design Guidelines for Residential Projects . . . . .	3-32
3.3.4 Setback Criteria . . . . .	3-34
3.3.5 Cleared Area Dispersion BMPs . . . . .	3-34
3.3.6 Design Guidelines for Road-Related Projects . . . . .	3-34
3.3.7 Native Vegetation Landscape Specifications . . . . .	3-36



3.3.8 Flow Credits for Full Dispersion . . . . . 3-38

**Chapter 4 Soil Quality BMPs. . . . . 3-39**

4.1 BMP L613 Post-Construction Soil Quality and Depth . . . . . 3-39

4.1.1 Purpose and Definition . . . . . 3-39

4.1.2 Applications and Limitations . . . . . 3-39

4.1.3 Infeasibility Criteria for Soil Quality BMPs. . . . . 3-39

4.1.4 Design Criteria . . . . . 3-39

4.1.5 Implementation Options: . . . . . 3-41

4.1.6 Maintenance . . . . . 3-46

4.1.7 Flow Reduction Credits for BMP L613 . . . . . 3-46

**Chapter 5 BMP L615 Tree Retention & Transplanting . . . . . 3-47**

5.1 Applications and Limitations. . . . . 3-47

5.2 Retained Trees . . . . . 3-47

5.2.1 Site Considerations . . . . . 3-47

5.2.2 Design Criteria . . . . . 3-47

5.2.3 Flow Control Credit . . . . . 3-50

5.3 Newly Transplanted Trees . . . . . 3-50

5.3.1 Site Considerations . . . . . 3-50

5.3.2 Design Criteria . . . . . 3-50

5.3.3 Flow Control Credit . . . . . 3-51

5.4 Operations and Maintenance Requirements . . . . . 3-52

**Chapter 6 Infiltration Facilities for Stormwater Flow Control . . . . . 3-53**

6.1 Purpose . . . . . 3-53

6.2 Description . . . . . 3-53

6.3 Design Methodology. . . . . 3-55

6.3.1 Select a location . . . . . 3-55

6.3.2 Estimate volume of stormwater, V<sub>design</sub> . . . . . 3-55

6.3.3 Develop trial infiltration facility geometry. . . . . 3-55

6.3.4 Complete a more detailed site characterization study and consider site suitability criteria . . . . . 3-55

6.3.5 Determine the infiltration rate . . . . . 3-55

6.3.6 Size the facility . . . . . 3-55

6.3.7 Construction Criteria . . . . . 3-56

6.3.8 Maintenance Criteria . . . . . 3-57

6.3.9 Verification Testing of the Completed Facility. . . . . 3-57

6.4 Site Characterization Criteria . . . . . 3-57

6.4.1 Surface Features Characterization . . . . . 3-57

6.4.2 Subsurface Characterization. . . . . 3-57

6.4.3 Infiltration Rate Determination. . . . . 3-58

6.4.4 Infiltration Receptor. . . . . 3-58

6.5 Design Saturated Hydraulic Conductivity – Guidelines and Criteria. . . . . 3-59

6.5.1 Large Scale Pilot Infiltration Test (PIT) . . . . . 3-59

6.5.2 Small Scale Pilot Infiltration Test (PIT) . . . . . 3-61

6.5.3 Soil Grain Size Analysis Method . . . . . 3-62

6.5.4 Correction Factors. . . . . 3-64

6.6 Site Suitability Criteria . . . . . 3-66

6.6.1 Setback Criteria. . . . . 3-66

6.6.2	Groundwater Protection Areas . . . . .	3-66
6.6.3	High Vehicle Traffic Areas . . . . .	3-66
6.6.4	Depth to Bedrock, Water Table, or Impermeable Layer . . . . .	3-67
6.6.5	Seepage Analysis and Control . . . . .	3-67
6.6.6	Cold Climate and Impact of Roadway Deicers . . . . .	3-67
6.7	Design Criteria for Infiltration Facilities . . . . .	3-67
6.7.1	Infiltration Facility Setbacks . . . . .	3-67
6.7.2	Pretreatment . . . . .	3-68
6.7.3	Infiltration Facility Access . . . . .	3-68
6.7.4	Infiltration Facility Overflow . . . . .	3-69
6.7.5	Infiltration Facility Seeps and Springs . . . . .	3-69
6.7.6	Infiltration Facility Construction Criteria . . . . .	3-69
6.7.7	Infiltration Facility Maintenance . . . . .	3-69
6.7.8	Infiltration Facility Easements . . . . .	3-69
6.8	Infiltration Basins . . . . .	3-69
6.8.1	Description . . . . .	3-70
6.8.2	Design Criteria Specific for Basins . . . . .	3-70
6.9	Infiltration Trenches . . . . .	3-70
6.9.1	Description . . . . .	3-70
6.9.2	Design Criteria . . . . .	3-70
6.9.3	Construction Criteria . . . . .	3-72
<b>Chapter 7</b>	<b>Detention Facilities for Stormwater Flow Control . . . . .</b>	<b>3-73</b>
7.1	Detention Facility Design Criteria . . . . .	3-73
7.1.1	Detention Facility Setbacks . . . . .	3-73
7.1.2	Detention Facility Access . . . . .	3-74
7.1.3	Detention Facility Overflow . . . . .	3-74
7.1.4	Detention Facility Seeps and Springs . . . . .	3-74
7.1.5	Detention Facility Maintenance . . . . .	3-74
7.1.6	Detention Facility Easements . . . . .	3-75
7.2	Detention Ponds . . . . .	3-75
7.2.1	Dam Safety for Detention Ponds . . . . .	3-75
7.2.2	Design Criteria Specific for Detention Ponds . . . . .	3-75
7.2.3	Methods of Analysis . . . . .	3-84
7.3	Detention Tanks . . . . .	3-86
7.3.1	Design Criteria . . . . .	3-88
7.4	Detention Vaults . . . . .	3-89
7.4.1	Design Criteria . . . . .	3-91
7.4.2	Methods of Analysis . . . . .	3-92
7.5	Control Structures . . . . .	3-92
7.5.1	Design Criteria . . . . .	3-92
7.5.2	Methods of Analysis . . . . .	3-94
<b>Chapter 8</b>	<b>Other Detention Options . . . . .</b>	<b>3-105</b>
8.1	Use of Parking Lots for Additional Detention . . . . .	3-105
8.2	Use of Roofs for Detention . . . . .	3-105
<b>Chapter 9</b>	<b>Conveyance System Design and Hydraulic Analysis . . . . .</b>	<b>3-107</b>
9.1	Design Methods for Conveyance Systems . . . . .	3-107
9.2	Methods of Analysis . . . . .	3-108

- 9.2.1 Onsite Analysis . . . . . 3-108
- 9.2.2 Offsite Analysis . . . . . 3-108
- 9.3 Hydrologic Modeling . . . . . 3-109
  - 9.3.1 Computer Models for Conveyance Systems . . . . . 3-109
  - 9.3.2 Single Segment Capacity Analysis . . . . . 3-109
  - 9.3.3 Full Backwater Analysis . . . . . 3-110
  - 9.3.4 Rational Method . . . . . 3-112
  - 9.3.5 Uniform Flow Analysis Design Events . . . . . 3-118
- 9.4 Inlet Grate Capacity . . . . . 3-119
  - 9.4.1 Inlet Types . . . . . 3-120
  - 9.4.2 Capacity of Inlets on a Continuous Grade . . . . . 3-121
  - 9.4.3 Side Flow Interception . . . . . 3-124
  - 9.4.4 Capacity of Inlets in Sag Locations . . . . . 3-125
- 9.5 Gutter Capacity Analysis . . . . . 3-129
- 9.6 Basis of Design . . . . . 3-131
- Chapter 10 Material Specifications . . . . . 3-133**
  - 10.1 Pipe Specifications . . . . . 3-133
    - 10.1.1 Pipe Materials . . . . . 3-133
    - 10.1.2 Pipe Sizes . . . . . 3-135
    - 10.1.3 Changes in Pipe Sizes . . . . . 3-135
    - 10.1.4 Pipe Alignment and Depth . . . . . 3-135
    - 10.1.5 Pipe Slopes and Velocities . . . . . 3-136
    - 10.1.6 Pipes on Steep Slopes . . . . . 3-136
    - 10.1.7 Pipe Clearances . . . . . 3-137
    - 10.1.8 Pipe Cover . . . . . 3-138
  - 10.2 Culvert Specifications . . . . . 3-138
    - 10.2.1 Inlets and Outlets . . . . . 3-139
  - 10.3 Open Channel Specifications . . . . . 3-139
    - 10.3.1 Natural Channels . . . . . 3-139
    - 10.3.2 Constructed Channels . . . . . 3-139
    - 10.3.3 Open Channel Design Criteria . . . . . 3-140
  - 10.4 Structures . . . . . 3-141
  - 10.5 System Connections . . . . . 3-144
  - 10.6 Debris Barriers . . . . . 3-146
  - 10.7 Riprap Design . . . . . 3-147
- Chapter 11 Outfall Systems . . . . . 3-151**
  - 11.1 Outfall Design Criteria . . . . . 3-151
    - 11.1.1 Energy dissipation . . . . . 3-152
    - 11.1.2 Flow dispersion . . . . . 3-152
  - 11.2 Tightline Systems . . . . . 3-158
  - 11.3 Habitat Considerations . . . . . 3-159
- Chapter 12 Pump Systems . . . . . 3-161**
  - 12.1 Design Criteria . . . . . 3-161
  - 12.2 Pump Requirements . . . . . 3-161
  - 12.3 Additional Requirements . . . . . 3-161
    - 12.3.1 Submittal Requirements . . . . . 3-162
  - 12.4 Sump Pumps . . . . . 3-163

**Chapter 13 Easements, Access, and Dedicated Tracts . . . . . 3-165**

    13.1 Stormwater Facilities . . . . . 3-165

        13.1.1 Public . . . . . 3-165

        13.1.2 Private . . . . . 3-165

    13.2 Conveyance Systems . . . . . 3-165

        13.2.1 Public . . . . . 3-165

        13.2.2 Private . . . . . 3-166

    13.3 Maintenance Access . . . . . 3-167

**Appendix A Tacoma Design Storm . . . . . 3-169**

**Appendix B Soils Reports . . . . . 3-171**

**Volume 4 - Source Control BMPs**

**Chapter 1 Frequently Asked Questions. . . . . 4-3**

    1.1 Applicability. . . . . 4-3

    1.2 Pollutants of Concern . . . . . 4-3

        1.2.1 pH . . . . . 4-3

        1.2.2 Total Suspended Solids . . . . . 4-3

        1.2.3 Oils and Greases . . . . . 4-3

        1.2.4 Oxygen-demanding Substances . . . . . 4-3

        1.2.5 Metals . . . . . 4-4

        1.2.6 Bacteria and Viruses . . . . . 4-4

        1.2.7 Nutrients . . . . . 4-4

        1.2.8 Toxic Organic Compounds . . . . . 4-4

        1.2.9 Other Chemicals and Substances. . . . . 4-4

    1.3 Types of Source Control BMPs . . . . . 4-5

        1.3.1 Operational BMPs . . . . . 4-5

        1.3.2 Structural BMPs . . . . . 4-5

**Chapter 2 Worksheet for Commercial and Industrial Activities . . . . . 4-7**

**Chapter 3 BMPs for Homeowners . . . . . 4-11**

    3.1 Automobile Washing (for Single-Family Residences) . . . . . 4-11

        3.1.1 Required BMPs . . . . . 4-11

        3.1.2 Suggested BMPs . . . . . 4-11

    3.2 Automobile Maintenance . . . . . 4-12

        3.2.1 Required BMPs . . . . . 4-12

        3.2.2 Suggested BMPs . . . . . 4-12

    3.3 Storage of Solid Wastes and Food Wastes . . . . . 4-13

        3.3.1 Required BMPs . . . . . 4-13

        3.3.2 Suggested BMPs . . . . . 4-13

    3.4 Composting . . . . . 4-13

        3.4.1 Required BMPs . . . . . 4-13

        3.4.2 Suggested BMPs . . . . . 4-14

    3.5 Yard Maintenance and Gardening . . . . . 4-14

        3.5.1 Required BMPs . . . . . 4-14

        3.5.2 Suggested BMPs . . . . . 4-14

    3.6 Swimming Pool and Spa Cleaning and Maintenance. . . . . 4-15

3.6.1 Required BMPs . . . . .	4-15
3.6.2 Suggested BMPs . . . . .	4-16
3.7 Household Hazardous Material Use, Storage, and Disposal . . . . .	4-16
3.7.1 Required BMPs . . . . .	4-16
3.7.2 Suggested BMPs . . . . .	4-16
3.8 General Home Maintenance . . . . .	4-17
3.8.1 Required BMPs . . . . .	4-17
3.8.2 Suggested BMPs . . . . .	4-17
3.9 Pet Waste . . . . .	4-18
3.9.1 Required BMPs . . . . .	4-18
<b>Chapter 4 BMPs for Commercial and Industrial Activities . . . . .</b>	<b>4-19</b>
4.1 BMPs for All Activities . . . . .	4-19
4.1.1 Mandatory Operational BMPs . . . . .	4-19
4.1.2 Mandatory Good Housekeeping BMPs . . . . .	4-20
4.1.3 Mandatory Preventive Maintenance BMPs: . . . . .	4-20
4.1.4 Additional Recommended BMPs: . . . . .	4-20
4.2 BMP W100: Washing Best Management Practices . . . . .	4-21
4.2.1 Cleaning or Washing of Tools, Equipment, and Machinery . . . . .	4-23
4.2.2 Cleaning or Washing of Cooking Equipment . . . . .	4-23
4.2.3 Building Structures and Related Equipment . . . . .	4-24
4.2.4 Interior Washing Operations . . . . .	4-25
4.2.5 Washing, Pressure Washing and Steam Cleaning of Vehicles . . . . .	4-26
4.3 Transfer of Liquid or Solid Materials . . . . .	4-28
4.3.1 BMP A201: Loading and Unloading Areas for Liquid or Solid Material . . . . .	4-28
4.3.2 BMP A202: Fueling at Dedicated Stations . . . . .	4-32
4.3.3 BMP A203: Vehicle Maintenance Activities . . . . .	4-32
4.3.4 BMP A204: Mobile Fueling of Vehicles and Heavy Equipment . . . . .	4-34
4.4 Production and Application Activities . . . . .	4-37
4.4.1 BMP A301: Concrete and Asphalt Mixing and Production at Stationary Sites . . . . .	4-37
4.4.2 BMP A302: Concrete Pouring, Concrete Cutting, and Asphalt Application at Temporary Sites . . . . .	4-38
4.4.3 BMP A303: Manufacturing and Post-Processing of Metal Products . . . . .	4-39
4.4.4 BMP A304: Wood Treatment Areas . . . . .	4-40
4.4.5 BMP A305: Commercial Composting . . . . .	4-40
4.4.6 BMP A306: Landscaping and Lawn/Vegetation Management . . . . .	4-41
4.4.7 BMP A307: Painting, Finishing and Coating of Vehicles, Boats, Buildings and Equipment . . . . .	4-45
4.4.8 BMP A308: Commercial Printing Operations . . . . .	4-46
4.4.9 BMP A309: Manufacturing Operations – Outside . . . . .	4-47
4.5 Storage and Stockpiling Activities . . . . .	4-49
4.5.1 BMP A401: Storage or Transfer (Outside) of Solid Raw Materials, By-Products or Finished Products . . . . .	4-49
4.5.2 BMP A402: Storage and Treatment of Contaminated Soils . . . . .	4-50
4.5.3 BMP A403: Temporary Storage or Processing of Fruits or Vegetables . . . . .	4-51
4.5.4 BMP A404: Storage of Solid Wastes and Food Wastes . . . . .	4-52
4.5.5 BMP A405: Farmer’s Markets . . . . .	4-53
4.5.6 BMP A406: Recyclers and Scrap Yards . . . . .	4-54
4.5.7 BMP A407: Treatment, Storage or Disposal of Dangerous Wastes . . . . .	4-54

4.5.8 BMP A408: Storage of Liquid, Food Waste or Dangerous Waste Containers . . .	4-55
4.5.9 BMP A409: Storage of Liquids in Above-Ground Tanks . . . . .	4-57
4.5.10 BMP A410: Parking and Storage for Vehicles and Equipment . . . . .	4-61
4.6 Construction and Demolition Activities . . . . .	4-62
4.6.1 BMP A501: Clearing, Grading and Preparation of Construction Sites . . . . .	4-62
4.6.2 BMP A502: Demolition of Buildings . . . . .	4-62
4.6.3 BMP A503: Building, Repair, Remodeling and Construction . . . . .	4-63
4.7 Dust Control, and Soil and Sediment Control . . . . .	4-65
4.7.1 BMP A601: Dust Control at Disturbed Land Areas and Unpaved Roadways and Parking Lots . . . . .	4-65
4.7.2 BMP A602: Dust Control at Manufacturing Sites . . . . .	4-66
4.7.3 BMP A603: Soil Erosion and Sediment Control at Industrial Sites . . . . .	4-67
4.8 Other Activities . . . . .	4-68
4.8.1 BMP A701: Commercial Animal Handling Areas . . . . .	4-68
4.8.2 BMP A702: Log Sorting and Handling . . . . .	4-68
4.8.3 BMP A703: Boat Building, Mooring, Maintenance and Repair . . . . .	4-69
4.8.4 BMP A704: Logging . . . . .	4-71
4.8.5 BMP A705: Mining and Quarrying of Sand, Gravel, Rock, Peat, Clay and Other Materials . . . . .	4-72
4.8.6 BMP A706: Swimming Pool and Spa Cleaning and Maintenance . . . . .	4-73
4.8.7 BMP A707: De-Icing and Anti-Icing Operations for Streets & Highways . . . . .	4-74
4.8.8 BMP A708: Roof and Building Drains at Manufacturing and Commercial Buildings 4-74	
4.8.9 BMP A709: Urban Streets . . . . .	4-75
4.8.10 BMP A710: Railroad Yards . . . . .	4-76
4.8.11 BMP A711: Maintenance of Utility Vaults . . . . .	4-77
4.8.12 BMP A712: Maintenance of Roadside Ditches and Culverts . . . . .	4-77
4.8.13 BMP A713: Spills of Oil and Hazardous Substances . . . . .	4-79
4.8.14 BMP A714: Water Reservoir, Transmission Mainline, Wellhead, and Hydrant Flushing Activities . . . . .	4-81
4.8.15 BMP S101: Eliminate Illicit Storm Drainage System Connections . . . . .	4-81
4.8.16 BMP S102: Dispose of Contaminated Stormwater and Waste Materials Properly . 4-82	
4.8.17 BMP S103: Discharge Process Wastewater to a Sanitary Sewer, Holding Tank, or Water Treatment System . . . . .	4-83
4.9 Cover and Surround Activities . . . . .	4-84
4.9.1 BMP S104: Cover the Activity with a Roof or Awning . . . . .	4-84
4.9.2 BMP S105: Cover the Activity with an Anchored Tarp or Plastic Sheet . . . . .	4-84
4.9.3 BMP S106: Pave the Activity Area and Slope to a Sump, Holding Tank, or Oil/Water Separator . . . . .	4-85
4.9.4 BMP S107: Surround the Activity Area with a Curb, Dike, or Berm or Elevate the Activity . . . . .	4-86
4.10 BMP S108: Implement Integrated Pest Management Measures . . . . .	4-88
4.11 BMP S109: Cleaning Catch Basins . . . . .	4-89
<b>Appendix A Quick Reference Phone Numbers . . . . .</b>	<b>4-91</b>
<b>Appendix B Recycling/Disposal of Vehicle Fluids and Other Wastes . . . . .</b>	<b>4-93</b>
<b>Appendix C Example of an Integrated Pest Management Program . . . . .</b>	<b>4-95</b>

**Appendix D Management of Street Wastes . . . . . 4-99**

**Volume 5 - Water Quality Treatment BMPs**

**Chapter 1 Treatment Facility Selection Process . . . . . 5-3**  
 1.1 Step-by-Step Selection Process for Treatment Facilities . . . . . 5-3

**Chapter 2 Treatment Facility Menus . . . . . 5-7**  
 2.1 Oil Control Menu. . . . . 5-7  
     2.1.1 Performance Goal. . . . . 5-7  
     2.1.2 Options . . . . . 5-7  
     2.1.3 Application on the Project Site . . . . . 5-8  
 2.2 Phosphorus Treatment Menu. . . . . 5-8  
     2.2.1 Performance Goal. . . . . 5-8  
     2.2.2 Options . . . . . 5-8  
 2.3 Enhanced Treatment Menu . . . . . 5-9  
     2.3.1 Performance Goal. . . . . 5-9  
     2.3.2 Options . . . . . 5-9  
 2.4 Basic Treatment Menu . . . . . 5-10  
     2.4.1 Performance Goal. . . . . 5-10  
     2.4.2 Options . . . . . 5-10

**Chapter 3 General Requirements for Stormwater Facilities . . . . . 5-13**  
 3.1 Design Flow Volume and Flow Rate . . . . . 5-13  
     3.1.1 Water Quality Design Flow Volume . . . . . 5-13  
     3.1.2 Water Quality Design Flow Rate . . . . . 5-13  
     3.1.3 Flows Requiring Treatment. . . . . 5-14  
     3.1.4 Rounding. . . . . 5-14  
 3.2 Sequence of Facilities . . . . . 5-14  
 3.3 Setbacks. . . . . 5-15  
 3.4 Easements, Access, and Dedicated Tracts . . . . . 5-16  
 3.5 Materials. . . . . 5-16  
 3.6 Maintenance of Stormwater Facilities. . . . . 5-16

**Chapter 4 Facility Liners . . . . . 5-17**  
 4.1 General Design Criteria . . . . . 5-17  
 4.2 Design Criteria for Low Permeability Liner Options . . . . . 5-19  
     4.2.1 Compacted Till Liners . . . . . 5-19  
     4.2.2 Clay Liners . . . . . 5-19  
     4.2.3 Geomembrane Liners . . . . . 5-19  
     4.2.4 Concrete Liners. . . . . 5-20  
     4.2.5 Treatment Liners . . . . . 5-20

**Chapter 5 Hydraulic Structures . . . . . 5-21**  
 5.1 Flow Splitter Designs . . . . . 5-21  
     5.1.1 General Design Criteria. . . . . 5-21  
     5.1.2 Materials . . . . . 5-21  
     5.1.3 Maintenance . . . . . 5-22  
 5.2 Flow Spreading Options . . . . . 5-24  
     5.2.1 General Design Criteria. . . . . 5-25

5.2.2 Maintenance . . . . .	5-29
<b>Chapter 6 Pretreatment . . . . .</b>	<b>5-31</b>
6.1 Purpose . . . . .	5-31
6.2 Application . . . . .	5-31
6.3 Best Management Practices (BMPs) for Pretreatment. . . . .	5-31
6.3.1 BMP T610 Presettling Basin . . . . .	5-31
<b>Chapter 7 Infiltration Treatment Facilities . . . . .</b>	<b>5-33</b>
7.1 Purpose . . . . .	5-33
7.2 Application . . . . .	5-33
7.3 Design Methodology. . . . .	5-33
7.3.1 Select a location . . . . .	5-33
7.3.2 Estimate volume of stormwater, $V_{design}$ . . . . .	5-33
7.3.3 Develop trial infiltration facility geometry. . . . .	5-33
7.3.4 Complete a more detailed site characterization study and consider site suitability criteria . . . . .	5-33
7.3.5 Determine the infiltration rate . . . . .	5-34
7.3.6 Size the facility . . . . .	5-34
7.3.7 Construction Criteria . . . . .	5-35
7.3.8 Maintenance Criteria . . . . .	5-35
7.3.9 Verification Testing of the Completed Facility. . . . .	5-35
7.4 Site Characterization Criteria . . . . .	5-35
7.4.1 Surface Features Characterization . . . . .	5-36
7.4.2 Subsurface Characterization. . . . .	5-36
7.4.3 Infiltration Rate Determination. . . . .	5-36
7.4.4 Soil Testing . . . . .	5-37
7.4.5 Infiltration Receptor. . . . .	5-37
7.5 Design Saturated Hydraulic Conductivity – Guidelines and Criteria . . . . .	5-38
7.5.1 Large Scale Pilot Infiltration Test (PIT) . . . . .	5-38
7.5.2 Small Scale Pilot Infiltration Test (PIT) . . . . .	5-39
7.5.3 Soil Grain Size Analysis Method. . . . .	5-41
7.5.4 Correction Factors. . . . .	5-42
7.6 Site Suitability. . . . .	5-43
7.6.1 Setback Criteria. . . . .	5-44
7.6.2 Groundwater Protection Areas . . . . .	5-44
7.6.3 High Vehicle Traffic Areas. . . . .	5-44
7.6.4 Soil Infiltration Rate/Drawdown Time for Treatment . . . . .	5-45
7.6.5 Depth to Bedrock, Water Table, or Impermeable Layer . . . . .	5-45
7.6.6 Soil Physical and Chemical Suitability for Treatment . . . . .	5-45
7.6.7 Seepage Analysis and Control . . . . .	5-46
7.6.8 Cold Climate and Impact of Roadway Deicers . . . . .	5-46
7.7 Best Management Practices (BMPs) for Infiltration Treatment . . . . .	5-47
7.7.1 Design Criteria for Infiltration Facilities . . . . .	5-47
7.7.2 BMP T710 Infiltration Basins. . . . .	5-48
7.7.3 BMP T720 Infiltration Trenches. . . . .	5-49
<b>Chapter 8 Sand Filtration Treatment Facilities . . . . .</b>	<b>5-53</b>
8.1 Purpose . . . . .	5-53
8.2 Description . . . . .	5-53



- 8.3 Applications and Limitations . . . . . 5-58
- 8.4 Site Suitability . . . . . 5-58
- 8.5 Design Criteria . . . . . 5-58
  - 8.5.1 Sand Filter Design Criteria and Sizing . . . . . 5-58
- 8.6 Construction Criteria . . . . . 5-61
- 8.7 Maintenance Criteria . . . . . 5-61
- 8.8 BMP T808 Basic Sand Filter . . . . . 5-61
- 8.9 BMP T809 Large Sand Filter . . . . . 5-61
  - 8.9.1 Additional Large Sand Filter Design Criteria . . . . . 5-61
- 8.10 BMP T810 Sand Filter Vault . . . . . 5-62
  - 8.10.1 Description (Figure 5 - 13 and Figure 5 - 14) . . . . . 5-62
  - 8.10.2 Applications and Limitations . . . . . 5-62
  - 8.10.3 Additional Design Criteria for Vaults . . . . . 5-62
- 8.11 BMP T820 Linear Sand Filter . . . . . 5-65
  - 8.11.1 Description . . . . . 5-65
  - 8.11.2 Application and Limitations . . . . . 5-65
  - 8.11.3 Additional Design Criteria for Linear Sand Filters . . . . . 5-65
- Chapter 9 Media Filter Drain (previously Ecology Embankment) – BMP T900 . 5-67**
- Chapter 10 Biofiltration Treatment Facilities . . . . . 5-69**
  - 10.1 Purpose . . . . . 5-69
  - 10.2 Applications . . . . . 5-69
  - 10.3 Site Suitability . . . . . 5-69
  - 10.4 Best Management Practices . . . . . 5-69
    - 10.4.1 BMP T1010 Basic Biofiltration Swale . . . . . 5-70
    - 10.4.2 BMP T1020 Wet Biofiltration Swale . . . . . 5-86
    - 10.4.3 BMP T1030 Continuous Inflow Biofiltration Swale . . . . . 5-88
    - 10.4.4 BMP T1040 Basic Filter Strip . . . . . 5-89
    - 10.4.5 BMP T1050: Compost-Amended Vegetated Filter Strip (CAVFS) . . . . . 5-93
- Chapter 11 Wetpool Facilities . . . . . 5-97**
  - 11.1 Purpose . . . . . 5-97
  - 11.2 Best Management Practices . . . . . 5-97
    - 11.2.1 BMP T1110 Wetponds - Basic and Large . . . . . 5-97
    - 11.2.2 BMP T1120 Wetvaults . . . . . 5-107
    - 11.2.3 BMP T1130 Stormwater Treatment Wetlands . . . . . 5-112
    - 11.2.4 BMP T1140 Combined Detention and Wetpool Facilities . . . . . 5-118
  - 11.3 Combined Detention and Wetvault . . . . . 5-121
  - 11.4 Combined Detention and Stormwater Wetland . . . . . 5-123
    - 11.4.1 Sizing Criteria . . . . . 5-123
    - 11.4.2 Design Criteria . . . . . 5-123
    - 11.4.3 Inlet and Outlet Criteria . . . . . 5-123
    - 11.4.4 Planting Requirements . . . . . 5-123
- Chapter 12 Oil Water Separators . . . . . 5-125**
  - 12.1 Purpose . . . . . 5-125
  - 12.2 Description . . . . . 5-125
  - 12.3 Applications/Limitations . . . . . 5-125
  - 12.4 Site Suitability . . . . . 5-128

- 12.5 Design Criteria . . . . . 5-129
  - 12.5.1 General Considerations . . . . . 5-129
  - 12.5.2 Criteria for Baffles . . . . . 5-129
  - 12.5.3 Maintenance . . . . . 5-129
- 12.6 Oil Water Separator BMPs . . . . . 5-130
  - 12.6.1 BMP T1110 API (Baffle type) Separators . . . . . 5-130
  - 12.6.2 BMP T1111 Coalescing Plate (CP) Separators . . . . . 5-133
- Chapter 13 Emerging Technologies . . . . . 5-135**
  - 13.1 Background . . . . . 5-135
  - 13.2 Emerging Technology and the City of Tacoma . . . . . 5-135
  - 13.3 Ecology Role in Evaluating Emerging Technologies . . . . . 5-135
  - 13.4 Evaluation of Emerging Technologies . . . . . 5-135
  - 13.5 Assessing Levels of Development of Emerging Technologies . . . . . 5-136
  - 13.6 Examples of Emerging Technologies for Stormwater Treatment and Control . . . . . 5-137
  - 13.7 Maintenance . . . . . 5-137
- Appendix A Basic Treatment Receiving Waters . . . . . 5-139**
- Appendix B Geotextile Specifications . . . . . 5-141**
- Appendix C Turbulence and Short-Circuiting Factor . . . . . 5-143**
- Appendix D South Tacoma Groundwater Protection District Infiltration Policy . . . . . 5-145**
- Appendix E Compost Specifications . . . . . 5-151**

**Volume 6 - Low Impact Development**

- Chapter 1 General Requirements . . . . . 6-3**
  - 1.1 Objectives . . . . . 6-3
  - 1.2 Site Assessment . . . . . 6-3
  - 1.3 Site Planning and Layout . . . . . 6-3
  - 1.4 Retain Native Vegetation . . . . . 6-3
  - 1.5 Minimize Clearing and Grading Impacts . . . . . 6-4
- Chapter 2 Low Impact Development Best Management Practices . . . . . 6-5**
  - 2.1 Application . . . . . 6-5
  - 2.2 Best Management Practices . . . . . 6-5
    - 2.2.1 Site Design BMPs . . . . . 6-5
    - 2.2.2 Structural Low Impact Development BMPS . . . . . 6-7
- Appendix A Recommended Modifications to ASTM D2434 When Measuring Hydraulic Conductivity for Bioretention Soil Mixes . . . . . 6-43**
- Appendix B Green Stormwater Infrastructure Details . . . . . 6-45**
- Glossary . . . . . 1**



# List of Tables

1 - 1. Quantitative Analysis Determination .....	1-48
1 - 2. Project Threshold Worksheet .....	1-57
1 - 3. Project Threshold Worksheet .....	1-68
1 - 4. Project Threshold Worksheet .....	1-70
2 - 1. Source Control BMPs by SWPPP Element .....	2-26
2 - 2. Temporary Erosion Control Seed Mix. ....	2-40
2 - 3. Landscaping Seed Mix .....	2-40
2 - 4. Low-Growing Turf Seed Mix .....	2-41
2 - 5. Bioswale Seed Mix .....	2-41
2 - 6. Wet Area Seed Mix. ....	2-41
2 - 7. Meadow Seed Mix .....	2-42
2 - 8. Mulch Standards and Guidelines .....	2-43
2 - 9. Materials on Hand. ....	2-67
2 - 10. Source Control BMPs by SWPPP Element .....	2-81
2 - 11. Storm Drain Inlet Protection .....	2-105
2 - 12. Geotextile Standards .....	2-118
2 - 13. Vegetated Strips .....	2-124
2 - 14. Flowpath Guidelines for Vegetative Filtration .....	2-128
2 - 15. Sediment Trap Sizing .....	2-131
2 - 16. Project Threshold Worksheet .....	2-159
3 - 1. Runoff Curve Numbers for Selected Agricultural, Suburban and Urban Areas .	3-7
3 - 2. Downspout Infiltration Length for USDA Soil Type. ....	3-12
3 - 3. Downspout Infiltration Drywell Sizing Table .....	3-13
3 - 4. Amendment Options .....	3-42
3 - 5. Calculated Amendment Rate .....	3-45
3 - 6. Flow Credits for Retained Trees. ....	3-50
3 - 7. Flow Credits for Newly Transplanted Trees .....	3-51
3 - 8. Measured Hydraulic Saturated Conductivity Rate Reduction Factors .....	3-64
3 - 9. Example Permanent Stormwater Control Pond Sign Specifications .....	3-82
3 - 10. Small Trees and Shrubs with Fibrous Roots .....	3-84
3 - 11. Values of Cd for Sutro Weirs .....	3-96
3 - 12. Runoff Coefficients - "C" Values for the Rational Method. ....	3-113
3 - 13. Coefficients for the Rational Method. ....	3-114
3 - 14. Rainfall Intensities (IR) (inches per hour) for the City of Tacoma. ....	3-115
3 - 15. "n" and "k" Values Used in Time Calculations for Hydrographs .....	3-117
3 - 16. Properties of Grate Inlets .....	3-119
3 - 17. Design Frequency and Spread .....	3-129

3 - 18. Acceptable Pipe Material in the City Right-of-Way . . . . .	3-133
3 - 19. Maximum Pipe Slopes, Velocities and Anchor Requirements . . . . .	3-137
3 - 20. Channel Protection . . . . .	3-147
3 - 21. Rock Protection at Outfalls . . . . .	3-151
3 - 22. Storm Drain Easement Widths . . . . .	3-166
3 - 23. Design Storm Precipitation Values . . . . .	3-169
4 - 1. Discharge Options for Businesses . . . . .	4-22
5 - 1. Treatment Trains for Phosphorus Removal . . . . .	5-9
5 - 2. Treatment Trains for Enhanced Treatment. . . . .	5-10
5 - 3. Treatment Facility Placement in Relation to Detention Facilities . . . . .	5-15
5 - 4. Lining Types Recommended for Runoff Treatment Facilities. . . . .	5-18
5 - 5. Acceptable Gradation for Compacted Till Liners . . . . .	5-19
5 - 6. Measured Hydraulic Saturated Conductivity Rate Reduction Factors . . . . .	5-42
5 - 7. Sand Specifications . . . . .	5-60
5 - 8. Clay Liner Specifications . . . . .	5-60
5 - 9. Sizing Criteria . . . . .	5-72
5 - 10. Stability Check Steps (SC) Guide for Selecting Degree of Retardance . . . . .	5-76
5 - 11. Guide to Selecting Maximum Permissible Swale Velocities for Stability . . . . .	5-77
5 - 12. Grass Seed Mixes Suitable for Biofiltration Swale Treatment Areas . . . . .	5-82
5 - 13. Groundcovers & Grasses Suitable for the Upper Side Slopes of a Biofiltration Swale in Western Washington . . . . .	5-83
5 - 14. Recommended Plants for Wet Biofiltration Swale . . . . .	5-84
5 - 15. Sizing Criteria . . . . .	5-91
5 - 16. Emergent Wetland Species Recommended for Wetponds . . . . .	5-105
5 - 17. Distribution of Depths in Wetland Cell . . . . .	5-117
5 - 18. Geotextile Properties for Underground Drainage . . . . .	5-141
5 - 19. Geotextile for Underground Drainage Filtration Properties. . . . .	5-141
5 - 20. Geotextile Strength Properties for Impermeable Liner Protection . . . . .	5-142
5 - 21. Mulch Standards and Guidelines . . . . .	5-151
6 - 1. Rain Garden Sizing and Geometry. . . . .	6-13
6 - 2. Measured Hydraulic Saturated Conductivity Rate Reduction Factors . . . . .	6-18
6 - 3. Bioretention Soil Mix Aggregate Component Gradation. . . . .	6-21
6 - 4. Underdrain sieve sizes . . . . .	6-24
6 - 5. WWHM Modeling Assumptions for Bioretention. . . . .	6-27
6 - 6. Measured Hydraulic Saturated Conductivity Rate Reduction Factors . . . . .	6-35
6 - 7. Permeable Ballast Grading Requirement. . . . .	6-37

# List of Figures

1 - 1. City of Tacoma Watersheds . . . . .	1-6
1 - 2. South Tacoma Groundwater Protection District (STGPD) . . . . .	1-14
1 - 3. NRDA Areas and Sensitive Habitat Sites (West Tacoma Area) . . . . .	1-15
1 - 4. NRDA Areas and Sensitive Habitat Sites (East Tacoma Area) . . . . .	1-16
1 - 5. New Development Flowchart . . . . .	1-29
1 - 6. Redevelopment Flowchart . . . . .	1-30
1 - 7. Road-Related Redevelopment Flowchart. . . . .	1-31
1 - 8. Minimum Requirement #5 Flowchart . . . . .	1-32
1 - 9. Flow Control Flowchart. . . . .	1-33
2 - 1. Stabilized Construction Entrance . . . . .	2-32
2 - 2. Small-Site Stabilized Construction Entrance . . . . .	2-33
2 - 3. Wheel Wash . . . . .	2-35
2 - 4. Nets and Blankets – Slope Installation. . . . .	2-49
2 - 5. Nets and Blankets – Channel Installation. . . . .	2-50
2 - 6. Surface Roughening by Tracking and Contour Furrows. . . . .	2-63
2 - 7. Gradient Terraces. . . . .	2-65
2 - 8. Temporary Concrete Washout Facility . . . . .	2-76
2 - 9. Prefabricated Concrete Washout Container with Ramp . . . . .	2-77
2 - 10. Typical Grass-Lined Channels . . . . .	2-87
2 - 11. Temporary Channel Liners . . . . .	2-88
2 - 12. Soil Erosion Protection – Rip Rap Protection . . . . .	2-90
2 - 13. Pipe Slope Drains . . . . .	2-94
2 - 14. Cross-Section of a Level Spreader. . . . .	2-98
2 - 15. Detail of a Level Spreader . . . . .	2-98
2 - 16. Check Dams . . . . .	2-101
2 - 17. Sediment Barrier – Geosynthetic Dike . . . . .	2-103
2 - 18. Drop Inlet with Block and Gravel Filter . . . . .	2-108
2 - 19. Gravel and Wire Mesh Filter. . . . .	2-109
2 - 20. Catchbasin Filter. . . . .	2-110
2 - 21. Block and Gravel Curb Inlet Protection. . . . .	2-112
2 - 22. Curb and Gutter Sediment Barrier . . . . .	2-114
2 - 23. Brush Barrier. . . . .	2-116
2 - 24. Silt Fence . . . . .	2-122
2 - 25. Silt Fence Installation by Slicing . . . . .	2-123
2 - 26. Straw Wattles . . . . .	2-126
2 - 27. Manifold and branches in a wooded, vegetated spray field . . . . .	2-129
2 - 28. Cross-Section of a Sediment Trap . . . . .	2-132

2 - 29. Sediment Trap Outlet . . . . .	2-132
2 - 30. Sediment Pond . . . . .	2-137
2 - 31. Sediment Pond Cross Section . . . . .	2-137
2 - 32. Sediment Pond Riser Detail . . . . .	2-138
2 - 33. Riser Inflow Curves. . . . .	2-139
2 - 34. Floating Platform with Struts. . . . .	2-142
2 - 35. Sample Erosion and Sediment Control Plan . . . . .	2-172
2 - 36. Construction Entrance . . . . .	2-173
2 - 37. Sediment Barrier – Silt Fence. . . . .	2-174
2 - 38. Sediment (Berm) Barrier – Straw Wattle Rolls . . . . .	2-175
2 - 39. Catch Basin Protection – Bag Filter . . . . .	2-176
2 - 40. Catch Basin Protection – Inlet Gravel and Filter Fabric . . . . .	2-177
2 - 41. Water Runoff Containment/Control – Sediment Trap Cross-Section . . . . .	2-178
2 - 42. Water Runoff Containment/Control – Sediment Trap Outlet . . . . .	2-179
2 - 43. Water Runoff Containment/Control – Drainage Swale Cross-Sections . . . . .	2-180
2 - 44. Soil Erosion Protection – Erosion Blankets and Turf Reinforcement Mats. . . . .	2-181
2 - 45. Soil Erosion Protection – Rip Rap Protection . . . . .	2-182
2 - 46. Soil Erosion Protection – Pipe Slope Drains. . . . .	2-183
3 - 1. USDA Textural Triangle . . . . .	3-11
3 - 2. Typical Downspout Infiltration Trench. . . . .	3-14
3 - 3. Alternative Infiltration Trench System for Coarse Sand and Gravel . . . . .	3-15
3 - 4. Typical Downspout Infiltration Drywell . . . . .	3-16
3 - 5. Setbacks for Splashblocks and Trench Dispersion . . . . .	3-20
3 - 6. Downspout Dispersion Trench . . . . .	3-21
3 - 7. Dispersion Trench with Notched Grade Board . . . . .	3-22
3 - 8. Downspout Splashblock Dispersion . . . . .	3-23
3 - 9. Perforated Stub-Out Connections. . . . .	3-25
3 - 10. Typical Concentrated Flow Dispersion for Steep Driveways . . . . .	3-29
3 - 11. Sheet Flow Dispersion for Driveways. . . . .	3-31
3 - 12. Standard Tree Measurement . . . . .	3-48
3 - 13. Tree Protection During Construction . . . . .	3-49
3 - 14. Typical Infiltration Pond/Basin . . . . .	3-54
3 - 15. Typical Detention Pond. . . . .	3-77
3 - 16. Typical Detention Pond Sections . . . . .	3-78
3 - 17. Overflow Structure . . . . .	3-79
3 - 18. Examples of Permanent Stormwater Control Pond Sign . . . . .	3-82
3 - 19. Weir Section for Emergency Overflow Spillway . . . . .	3-85
3 - 20. Typical Detention Tank. . . . .	3-86
3 - 21. Detention Tank Access Detail. . . . .	3-87
3 - 22. Typical Detention Vault. . . . .	3-90

3 - 23. Flow Restrictor (TEE) . . . . .	3-97
3 - 24. Flow Restrictor (Baffle) . . . . .	3-98
3 - 25. Flow Restrictor (Weir) . . . . .	3-99
3 - 26. Simple Orifice . . . . .	3-100
3 - 27. Rectangular, Sharp-Crested Weir . . . . .	3-100
3 - 28. V-Notch, Sharp-Crested Weir . . . . .	3-101
3 - 29. Sutro Weir . . . . .	3-102
3 - 30. Riser Inflow Curves . . . . .	3-103
3 - 31. Section at Inlet . . . . .	3-122
3 - 32. Sag Analysis . . . . .	3-127
3 - 33. Typical Gutter Section . . . . .	3-130
3 - 34. Debris Barrier . . . . .	3-146
3 - 35. Mean Channel Velocity vs Medium Stone Weight (W50) and Equivalent Stone Diameter . . . . .	3-149
3 - 36. Riprap Gradation Curve . . . . .	3-150
3 - 37. Pipe/Culvert Outfall Discharge Protection . . . . .	3-154
3 - 38. Flow Dispersal Trench . . . . .	3-155
3 - 39. Alternative Flow Dispersal Trench . . . . .	3-156
3 - 40. Gabion Outfall Detail . . . . .	3-157
3 - 41. Diffuser TEE (an example of energy dissipating end feature) . . . . .	3-158
4 - 1. Drip Pan . . . . .	4-28
4 - 2. Drip Pan Within Rails . . . . .	4-30
4 - 3. Loading Dock with Door Skirt . . . . .	4-31
4 - 4. Loading Dock with Overhang . . . . .	4-31
4 - 5. Enclose the Activity . . . . .	4-48
4 - 6. Cover the Activity . . . . .	4-48
4 - 7. Covered Storage Area for Bulk Solids (including berm if needed) . . . . .	4-50
4 - 8. Secondary Containment Vessel . . . . .	4-56
4 - 9. Locking System for Drum Lid . . . . .	4-56
4 - 10. Covered and Bermed Containment Area . . . . .	4-57
4 - 11. Mounted Container . . . . .	4-57
4 - 12. Above-Ground Tank Storage . . . . .	4-59
4 - 13. Above-Ground Tank with Impervious Walls and Floor . . . . .	4-60
4 - 14. Standby Generator . . . . .	4-60
4 - 15. Examples of Covered Activities . . . . .	4-84
4 - 16. Tarp Covering . . . . .	4-85
4 - 17. Paved Area with Sump Drain . . . . .	4-86
4 - 18. Containment Types . . . . .	4-87
4 - 19. Standby Generator . . . . .	4-88
5 - 1. Flow Splitter, Option A . . . . .	5-23



5 - 2. Flow Splitter, Option B . . . . .	5-24
5 - 3. Flow Spreader Option A – Anchored Plate. . . . .	5-26
5 - 4. Flow Spreader Option B – Concrete Sump Box . . . . .	5-27
5 - 5. Flow Spreader Option C – Notched Curb Spreader . . . . .	5-28
5 - 6. Flow Spreader Option D – Through-Curb Ports . . . . .	5-29
5 - 7. Observation Well Details . . . . .	5-51
5 - 8. Sand Filtration Basin Preceded by Presettling Basin (Variation of a Basic Sand Filter) . . . . .	5-53
5 - 9. Sand Filter with a Pretreatment Cell (top view) . . . . .	5-54
5 - 10. Sand Filter with a Pretreatment Cell (side view). . . . .	5-55
5 - 11. Sand Filter with Level Spreader (top view) . . . . .	5-56
5 - 12. Sand Filter with Level Spreader (side view) . . . . .	5-57
5 - 13. Sand Filter Vault (top view). . . . .	5-63
5 - 14. Sand Filter Vault (side view). . . . .	5-64
5 - 15. Linear Sand Filter . . . . .	5-66
5 - 16. Typical Swale Section. . . . .	5-70
5 - 17. Geometric Formulas for Common Swale Shapes . . . . .	5-71
5 - 18. The Relationship of Manning’s n with VR for Various Degrees of Flow Retardance (A-E). . . . .	5-77
5 - 19. Biofiltration Swale Underdrain Detail . . . . .	5-79
5 - 20. Biofiltration Swale Low-Flow Drain Detail . . . . .	5-79
5 - 21. Swale Dividing Berm. . . . .	5-80
5 - 22. Biofiltration Swale Access Features . . . . .	5-85
5 - 23. Typical Filter Strip . . . . .	5-90
5 - 24. Compost Amended Vegetated Filter Strip (CAVFS). . . . .	5-95
5 - 25. Wetpond (top view). . . . .	5-98
5 - 26. Wetpond (side view) . . . . .	5-99
5 - 27. Wetvault . . . . .	5-108
5 - 28. Stormwater Wetland – Option 1 . . . . .	5-115
5 - 29. Stormwater Wetland – Option 2 . . . . .	5-116
5 - 30. Combined Detention and Wetpond (top view) . . . . .	5-119
5 - 31. Combined Detention and Wetpond (side view) . . . . .	5-120
5 - 32. Alternative Configurations of Detention and Wetpool Areas. . . . .	5-122
5 - 33. API (Baffle Type) Separator . . . . .	5-126
5 - 34. Coalescing Plate Separator . . . . .	5-127
5 - 35. Spill Control Separator (not for oil treatment) . . . . .	5-128
5 - 36. Recommended Values of F for Various Values of $vH/Vt$ . . . . .	5-143
G - 1. Threshold Discharge Area . . . . .	7-55





# Preface

The most recent National Pollutant Discharge Elimination System (NPDES) Phase I Municipal Stormwater Permit (NPDES Permit) became effective August 1, 2013. Section S5.C.5 of the NPDES Permit requires municipalities to “include a program to prevent and control the impacts of runoff from new development, redevelopment, and construction activities.” This manual is designed to be equivalent to Ecology’s 2012 Stormwater Management Manual for Western Washington in order to meet the permit requirement. This manual was adopted by reference into the City of Tacoma Municipal Code 12.08 on November 24, 2015. The manual becomes effective on January 7, 2016.

## Objective

The objective of this manual is to establish minimum requirements for development and redevelopment projects of all sizes in the City of Tacoma. The minimum requirements are satisfied by the application of Best Management Practices (BMPs). This manual is applicable to all types of land development – including residential, commercial, industrial, and roads.

Volume 4 of this manual is used for source control of new and ongoing operations as well as everyday activities.

The primary reason for using BMPs is to protect beneficial uses of water resources through the reduction of pollutant loads and concentrations, and through reduction of discharges (volumetric flow rates) causing stream channel erosion. If it is found that, after the implementation of BMPs advocated in this manual, beneficial uses are still threatened or impaired, additional controls may be appropriate.

This manual can also be helpful in identifying options for retrofitting BMPs at existing development sites where appropriate. In such situations, application of BMPs from this manual is encouraged. The City recognizes, however, that there can be site constraints that make the strict application of these BMPs difficult in retrofit applications.

This manual also contains requirements for stormwater mitigation and stormwater design for projects that are not considered development and redevelopment sites. Environmental Services will advise the applicant which sections of the manual may apply to their project.

It is not the intent of this manual to make the City of Tacoma a guarantor or protector of public or private property with regard to land development activities.

## Organization of this Manual

The Stormwater Management Manual contains six volumes, a Glossary and References

- **Volume 1** defines the geographic scope of the manual, provides reference information for the stormwater system, and outlines the minimum requirements for development and redevelopment.
- **Volume 2** describes BMPs for short-term stormwater management during construction activities.
- **Volume 3** covers onsite stormwater management, flow control, and conveyance.
- **Volume 4** describes BMPs to minimize pollution generated by typical ongoing activities.
- **Volume 5** presents BMPs for water quality treatment.
- **Volume 6** presents BMPs for low impact development.
- A **Glossary** at the end of the manual defines terminology used in all six volumes.
- A list of **References** provides both source documentation and a list of additional information resources.

## How to Use this Manual

This manual is designed for a variety of users.

- Project proponents should start by reviewing the minimum requirements described in Volume 1. Volume 1 also describes the various components needed to comply with the Minimum Requirements, and provides guidance on how to develop required documents.
- City staff will use this manual to review Stormwater Site Plans, check BMP designs and provide technical advice to project proponents. All development and redevelopment projects within the City of Tacoma shall meet the requirements of this manual unless specifically exempted by this manual or the Director.
- The Director shall have authority to modify requirements to protect the health, safety or welfare of the public on the basis of information regarding threatened water quality, erosion problems or potential habitat destruction, flooding, protection of uninterrupted services, or endangerment to property. The Director shall also have the authority to modify requirements based upon increases in requirements imposed by state or federal agencies, where existing requirements are not applicable to the particular site, or other pertinent factors. Modifications to Minimum Requirements shall follow the requirements of Volume 1, Section 3.5 - Exceptions/Adjustments as applicable.
- Other permittees (e.g, Industrial or Sand and Gravel permittees) may refer to this manual or the BMPs contained in this manual.

Where requirements in this manual are also mandated by any other law, ordinance, resolution, rule or regulation, the more restrictive requirement shall apply.

Minor revisions to the manual may occur on an ongoing basis. It is the applicant's responsibility to verify the requirements when developing stormwater mitigation plans. As needs are identified, additional policies shall be developed and posted to the City website at:

[www.cityoftacoma.org/stormwatermanual](http://www.cityoftacoma.org/stormwatermanual)

## **Development of Best Management Practices (BMPs) for Stormwater Management**

This manual contains Best Management Practices, that when properly designed and implemented, control the adverse impacts of development and redevelopment.

### **Best Management Practices (BMPs)**

Best Management Practices are defined as schedules of activities, prohibitions of practices, maintenance procedures, and structural and/or managerial practices, that when used singly or in combination, prevent or reduce the release of pollutants and other adverse impacts to waters of Washington State. The types of BMPs include source control, treatment, and flow control.

## **Related Documentation**

### **Department of Ecology's Stormwater Management Manual**

This manual was modeled after the Stormwater Management Manual for Western Washington, published by the Department of Ecology in August 2012. Ecology's stormwater manual was originally developed in response to a directive of the Puget Sound Water Quality Management Plan (PSWQA 1987 et seq.). The Puget Sound Water Quality Authority (since replaced by the Puget Sound Partnership) recognized the need for overall guidance for stormwater quality improvement. It incorporated requirements in its plan to implement a cohesive, integrated stormwater management approach through the development and implementation of programs by local jurisdictions, and the development of rules, permits and guidance by Ecology.

The Puget Sound Water Quality Management Plan included a stormwater element (SW-2.1) requiring Ecology to develop a stormwater technical manual for use by local jurisdictions. Ecology's original stormwater manual (the Stormwater Management Manual for the Puget Sound Basin, published in 1992) was developed to meet this requirement.

### **Federal, State and Local Regulatory Requirements**

The applicant is responsible for identifying and complying with all applicable federal, state, and regulatory requirements. Projects may have site specific requirements if they are part of a Superfund or cleanup site.

The Office of Regulatory Assistance website is a useful tool for determining additional permitting requirements that may apply to a project: [www.ora.wa.gov](http://www.ora.wa.gov)

The City of Tacoma Permitting website ([tacomapermits.org](http://tacomapermits.org)) is a good tool for determining additional regulations that may be posed by other City of Tacoma Departments.

The Washington State Department of Ecology Toxics Cleanup Program website provides information on Washington State cleanup sites: <http://www.ecy.wa.gov/programs/tcp/cleanup.html>

The EPA Washington Cleanup Site website can be used to determine if a project is located in or discharges to a Superfund Site:

<http://yosemite.epa.gov/r10/cleanup.nsf/webpage/Washington+Cleanup+Sites!OpenDocument&Count=250&ResortAscending=1>

**Other Stormwater Permits**

There are sites in the City of Tacoma covered under separate Industrial Stormwater General Permits, Construction Stormwater General Permits, Sand and Gravel General Permits, or separate State issued Discharge Permits. Development at these sites may be required to comply with the minimum requirements and design standards in this manual. Environmental Services will determine which requirements apply to a given project.

Certain projects are exempt from obtaining permits from local jurisdictions. These sites may still be required to comply with the minimum requirements and design standards in this manual. Projects exempt from permitting may require stormwater mitigation review and approval from the City of Tacoma before discharging stormwater to the City of Tacoma Municipal Separate Storm Sewer System (MS4).

Within the City of Tacoma limits, the Port of Tacoma, Metropolitan Park District of Tacoma, and Tacoma Community College are considered Secondary Permittees. Each permittee is responsible for the MS4 they own or operate. Environmental Services will review all projects within the City of Tacoma.

# Volume 1 - Stormwater Site Planning

## Table of Contents

Purpose of this Volume . . . . .	1-1
Content and Organization of this Volume . . . . .	1-1
<b>Chapter 1 Development Impacts . . . . .</b>	<b>1-3</b>
<b>Chapter 2 Watershed Designations . . . . .</b>	<b>1-5</b>
2.1 City of Tacoma Watersheds . . . . .	1-5
2.2 Land Use . . . . .	1-7
2.2.1 Comprehensive Planning . . . . .	1-7
2.3 Impaired Water Bodies . . . . .	1-7
2.4 Floodplains . . . . .	1-7
2.5 Tacoma’s Watersheds and Other Basins – Summary Descriptions . . . . .	1-8
2.5.1 Flett Creek . . . . .	1-8
2.5.1.1 Wapato Lake . . . . .	1-8
2.5.1.2 Snake Lake . . . . .	1-9
2.5.2 Leach Creek . . . . .	1-9
2.5.2.1 Leach Creek Holding Basin . . . . .	1-9
2.5.3 Northeast Tacoma . . . . .	1-10
2.5.4 Joe’s Creek . . . . .	1-10
2.5.5 North Tacoma . . . . .	1-10
2.5.5.1 Puget Creek . . . . .	1-10
2.5.6 Thea Foss Waterway . . . . .	1-11
2.5.7 Tidelands . . . . .	1-11
2.5.8 Lower Puyallup . . . . .	1-11
2.5.8.1 Puyallup River . . . . .	1-11
2.5.8.2 Swan Creek . . . . .	1-11
2.5.8.3 First Creek (formerly T-Street Gulch) . . . . .	1-12
2.5.9 Western Slopes Watershed . . . . .	1-12
2.5.10 South Tacoma Groundwater Protection District . . . . .	1-12
2.5.11 Sensitive Habitat Areas . . . . .	1-13
<b>Chapter 3 Minimum Requirements for New Development and Redevelopment . . . . .</b>	<b>1-17</b>
3.1 Overview of the Minimum Requirements . . . . .	1-17
3.2 Exemptions . . . . .	1-17
3.2.1 Pavement Maintenance . . . . .	1-18
3.2.2 Underground Utility Projects . . . . .	1-18
3.2.3 Minor Clearing and Grading . . . . .	1-18
3.2.4 Emergencies . . . . .	1-19
3.3 Applicability of the Minimum Requirements . . . . .	1-19
3.3.1 New Development . . . . .	1-20
3.3.2 Redevelopment . . . . .	1-20
3.3.2.1 Roads and Redevelopment . . . . .	1-21
3.3.3 Equivalent Areas . . . . .	1-21
3.3.4 Cumulative Impact Mitigation Requirement and Vesting . . . . .	1-22
3.3.5 Grade and Fill Projects . . . . .	1-22



- 3.3.6 Separation of Public and Private Water Quality and Flow Control . . . . . 1-22
- 3.3.7 Watershed Specific Requirements . . . . . 1-23
  - 3.3.7.1 Flett Creek . . . . . 1-23
  - 3.3.7.2 Leach Creek . . . . . 1-24
  - 3.3.7.3 Northeast Tacoma . . . . . 1-24
  - 3.3.7.4 Joe’s Creek . . . . . 1-25
  - 3.3.7.5 North Tacoma . . . . . 1-25
  - 3.3.7.6 Thea Foss Watershed . . . . . 1-26
  - 3.3.7.7 Tidelands Watershed . . . . . 1-26
  - 3.3.7.8 Lower Puyallup Watershed . . . . . 1-27
  - 3.3.7.9 Western Slopes Watershed . . . . . 1-27
- 3.3.8 Flowcharts . . . . . 1-28
- 3.4 Description of Minimum Requirements . . . . . 1-34
  - 3.4.1 Minimum Requirement #1: Preparation of a Stormwater Site Plan . . . . . 1-34
    - 3.4.1.1 Objective . . . . . 1-34
  - 3.4.2 Minimum Requirement #2: Construction Stormwater Pollution Prevention . . . . . 1-34
    - 3.4.2.1 Objective . . . . . 1-35
  - 3.4.3 Minimum Requirement #3: Source Control of Pollution . . . . . 1-35
    - 3.4.3.1 Objective . . . . . 1-35
  - 3.4.4 Minimum Requirement #4: Preservation of Natural Drainage Systems and Outfalls . . . . . 1-35
    - 3.4.4.1 Objective . . . . . 1-36
    - 3.4.4.2 Supplemental Guidelines . . . . . 1-36
  - 3.4.5 Minimum Requirement #5: Onsite Stormwater Management . . . . . 1-36
    - 3.4.5.1 Project Thresholds - Minimum Requirements #1-5 . . . . . 1-37
    - 3.4.5.2 Project Thresholds – Minimum Requirements #1 - #10 . . . . . 1-37
    - 3.4.5.3 Project Thresholds – Marine Waterbodies and Flow Control Exempt Waterbodies 1-37
    - 3.4.5.4 Low Impact Development Performance Standard . . . . . 1-38
    - 3.4.5.5 List #1 Onsite Management BMPs for Projects Triggering only Minimum Requirement #1- #5 . . . . . 1-38
    - 3.4.5.6 List #2 Onsite Management BMPs for Projects Triggering Minimum Requirements #1- #10 . . . . . 1-39
    - 3.4.5.7 Competing Needs . . . . . 1-40
    - 3.4.5.8 Objective . . . . . 1-40
  - 3.4.6 Minimum Requirement #6: Water Quality Treatment . . . . . 1-40
    - 3.4.6.1 Thresholds . . . . . 1-40
    - 3.4.6.2 Treatment Facility Selection, Design, and Maintenance . . . . . 1-41
    - 3.4.6.3 Additional Requirements . . . . . 1-41
    - 3.4.6.4 In-Lieu of Payment Option . . . . . 1-41
    - 3.4.6.5 Objective . . . . . 1-41
  - 3.4.7 Minimum Requirement #7: Flow Control . . . . . 1-42
    - 3.4.7.1 Flow Control Applicability . . . . . 1-42
    - 3.4.7.2 Freshwater Protection Requirement . . . . . 1-42
    - 3.4.7.3 Infrastructure Protection Requirement . . . . . 1-43
    - 3.4.7.4 Flow Control Exempt Waterbodies . . . . . 1-44
    - 3.4.7.5 Modeling Requirements . . . . . 1-44
    - 3.4.7.6 Flow Control Design, Offsite Inflow, and Bypass . . . . . 1-45
    - 3.4.7.7 Objective . . . . . 1-45
  - 3.4.8 Minimum Requirement #8: Wetlands Protection . . . . . 1-45
    - 3.4.8.1 Applicability . . . . . 1-46
    - 3.4.8.2 Thresholds . . . . . 1-46
    - 3.4.8.3 Standard Requirement . . . . . 1-46
    - 3.4.8.4 Additional Requirements . . . . . 1-46

3.4.8.5 Objective	1-46
3.4.9 Minimum Requirement #9: Operation and Maintenance	1-46
3.4.9.1 Objective	1-47
3.4.9.2 Supplemental Guidelines	1-47
3.4.10 Minimum Requirement #10: Offsite Analysis and Mitigation	1-47
3.4.10.1 Qualitative Analysis	1-47
3.4.10.2 Quantitative Analysis	1-47
3.4.10.3 City-Wide Capacity Modeling	1-48
3.4.10.4 Mitigation – Infrastructure Protection	1-48
3.4.10.5 Objective	1-49
3.5 Exceptions/Adjustments	1-50
3.5.1 Exceptions to the Minimum Requirements	1-50
3.5.2 Adjustments	1-50
3.5.3 Other Exceptions	1-51
<b>Chapter 4 Preparation of Stormwater Site Plans</b>	<b>1-53</b>
4.1 Stormwater Site Plan Checklist	1-53
4.2 Plans Required After Approval	1-65
4.2.1 Revisions	1-65
4.2.2 Record Drawing Submittal	1-66
4.2.3 Engineer's Certification	1-66
4.3 Land Use Submittal Requirements	1-66
<b>Appendix A Stormwater Site Plan Report Short Form</b>	<b>1-69</b>
<b>Appendix B Hydraulic Analysis Worksheet</b>	<b>1-79</b>
<b>Appendix C Maintenance Standards for Drainage Facilities</b>	<b>1-83</b>
#1 - Maintenance Checklist for Detention Ponds	1-85
#2 - Maintenance Checklist for Infiltration Ponds/Basins	1-89
#3 - Maintenance Checklist for Infiltration Trenches	1-93
#4 - Maintenance Checklist for Closed Detention Systems (Tanks/Vaults)	1-95
#5 - Maintenance Checklist for Control Structure/Flow Restrictor	1-97
#6 - Maintenance Checklist for Catch Basins/Manholes	1-99
#7 - Maintenance Checklist for Debris Barriers (e.g., Trash Racks)	1-102
#8 - Maintenance Checklist for Energy Dissipaters	1-103
#9 - Maintenance Checklist for Typical Biofiltration Swale	1-107
#10 - Maintenance Checklist for Wet Biofiltration Swales	1-110
#11 - Maintenance Checklist for Filter Strips	1-112
#12 - Maintenance Checklist for Wet Ponds	1-114
#13 - Maintenance Checklist for Treatment Wetlands	1-117
#14 - Maintenance Checklist for Wet Vaults	1-123
#15 - Maintenance Checklist for Sand Filters (above ground/open)	1-125
#16 - Maintenance Checklist for Sand Filters (below ground/enclosed)	1-127
#17 - Maintenance Checklist for Baffle Oil/Water Separators - American Petroleum Institute (API) Type 1-130	
#18 - Maintenance Checklist for Coalescing Plate Oil/Water Separators	1-132
#19 - Maintenance Checklist for Fencing/Shrubbery Screen/Other Landscaping	1-134
#20 - Maintenance Checklist for Gates	1-135
#21 - Maintenance Checklist for Grounds (Landscaping)	1-136

- #22 - Maintenance Checklist for Bioretention Facilities ..... 1-138
- #23 - Maintenance Checklist for Rain Gardens ..... 1-157
- #24 - Maintenance Checklist for Cisterns ..... 1-163
- #25 - Maintenance Checklist for Compost Amended Soil ..... 1-165
- #26 - Maintenance Checklist for Vegetated Roof ..... 1-168
- #27 - Maintenance Checklist for Pervious Pavement ..... 1-174
- #28 - Maintenance Checklist for Ballasted Sidewalk ..... 1-185
- #29 - Proprietary Stormwater Devices (Emerging Technologies) ..... 1-186
- #30 - General Maintenance Concerns for Stormwater Facilities ..... 1-187
- #31 - Maintenance Checklist for Trees ..... 1-189
- #32 - Downspout Infiltration Trench or Drywell ..... 1-190
- #33 - Downspout Dispersion ..... 1-192
- Appendix D Guidelines for Wetlands when Managing Stormwater ..... 1-197**
  - D.1 Scope and Principles .....1-198
  - D.2 Information Needed to Apply the Guidelines .....1-204
  - D.3 Definitions. ....1-205



# Stormwater Site Planning

## **Purpose of this Volume**

This volume provides a discussion of the Minimum Requirements for stormwater management, and information and guidance for preparing a Stormwater Site Plan.

## **Content and Organization of this Volume**

Volume 1 addresses key information to consider for Stormwater Site Planning.

- Chapter 1 describes the impacts of development and redevelopment on stormwater runoff and water quality.
- Chapter 2 identifies the geographic scope of the watersheds and basins within the City of Tacoma, and describes the requirements specific to each.
- Chapter 3 defines the Minimum Requirements for stormwater management for development and redevelopment projects.
- Chapter 4 describes the Stormwater Site Plan, and provides step-by-step guidance for preparing the plan.
- The Appendices provide reference information that may be useful for developing the Stormwater Site Plan, Operations and Maintenance manual and other documents.

In addition “Guidelines for Wetlands when Managing Stormwater” is contained as an Appendix.

**This Page Intentionally Left Blank**

## **Chapter 1 Development Impacts**

Stormwater is rain and snow melt that runs off surfaces such as rooftops, streets, parking lots, lawns, and sidewalks. Runoff from these surfaces picks up pollution such as oils and grease, heavy metals, trash, sediment, organic pollutants, herbicides, pesticides, and animal wastes. Stormwater is the leading contributor to water quality pollution in urban waters in Washington State. Untreated stormwater runoff can contaminate drinking water sources and cause beach closures for swimming and shellfish harvesting. Urban stormwater harms and pollutes streams and waterways that provide habitat for fish and other wildlife. Habitat loss from stormwater runoff has been identified as a primary obstacle to salmon recovery

In addition to stormwater pollution, stormwater runoff increases peak flow which cause hydrologic impacts such as scoured streambed channels, and loss of instream habitat.

Development increases or alters stormwater discharge characteristics.

**This Page Intentionally Left Blank**

## Chapter 2 Watershed Designations

This chapter identifies and describes the watersheds, basins and sub-basins within the City of Tacoma, and the requirements that are specific to each. Where requirements have been developed for a particular geographic area, these requirements shall be in addition to the Minimum Requirements found in Chapter 3 of this volume unless the text in this chapter specifically indicates that the area-specific requirement supersedes or replaces a Minimum Requirement.

Water Resource Inventory Areas (WRIAs) and watersheds are defined as follows:

- **WRIAs** – These are large watersheds based on geographic areas usually associated with large river systems. There are 62 of them which have been identified throughout the state by the Department of Ecology. Portions of two WRIAs are located in Tacoma. They are the Puyallup WRIA (#10) and the Chambers-Clover WRIA (#12).
- **Watersheds** – Nine smaller watersheds have been identified in Tacoma. Some of these watersheds are associated with stream systems and some of them are identified geographically. Many of these watersheds cross political boundaries and are shared by one or more of the municipalities surrounding Tacoma.

Information in this document will refer to Tacoma's nine watersheds and not to the WRIA's. Information on the WRIA's can be found at

<http://www.ecy.wa.gov/apps/watersheds/wriapages>

### 2.1 City of Tacoma Watersheds

The information in this manual covers the following nine watershed areas (see Figure 1 - 1).

- Flett Creek
- Leach Creek
- Northeast Tacoma
- Joe's Creek
- North Tacoma
- Thea Foss Waterway
- Tideflats
- Lower Puyallup
- Western Slopes



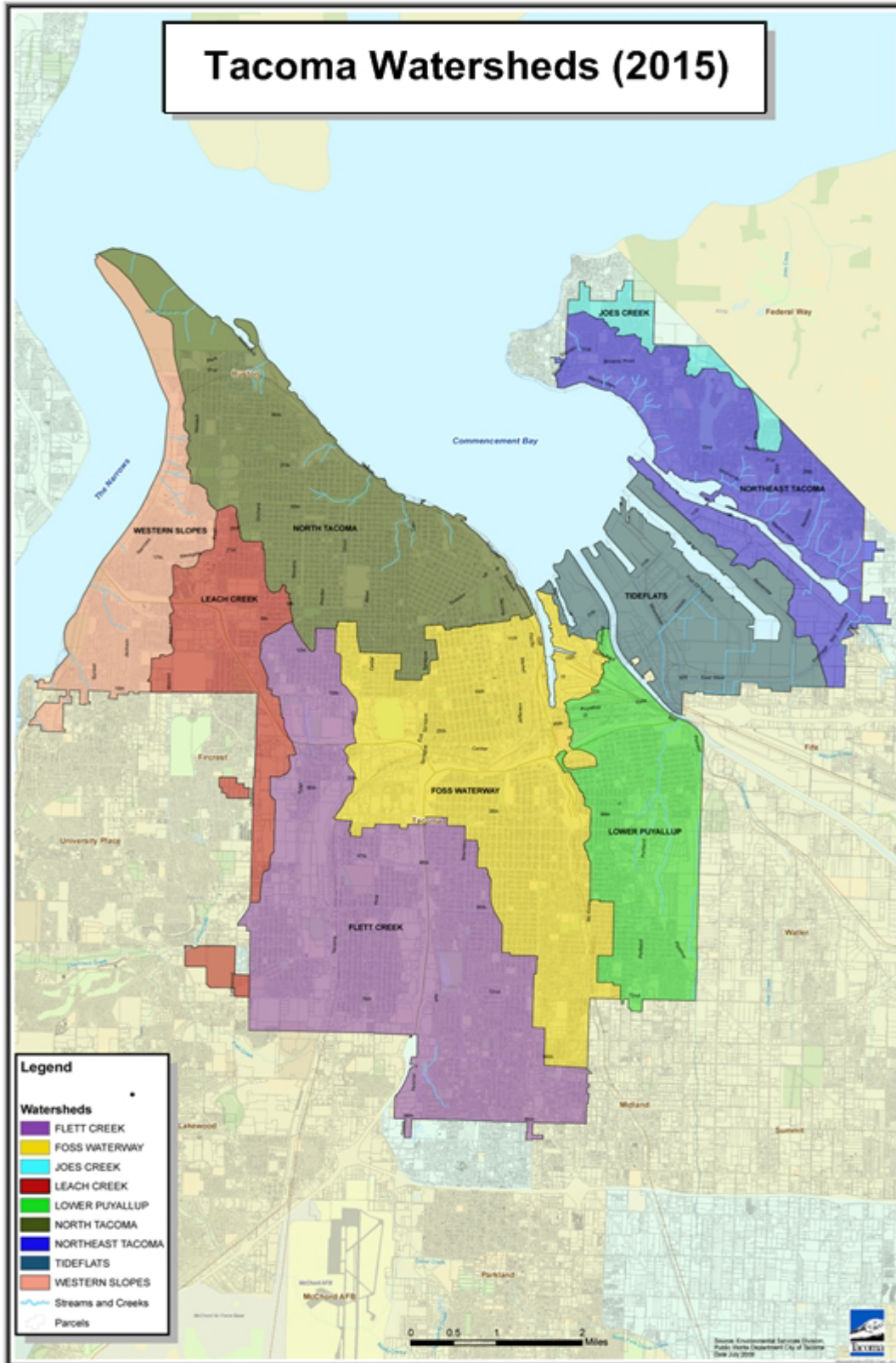


Figure 1 - 1. City of Tacoma Watersheds

The City shares watersheds with both Pierce and King Counties, and with various municipalities within these counties.

## **2.2 Land Use**

One of the factors determining the need for, and type of, area-specific controls, is the existing level of development and the types of land uses within a particular basin. Within the City of Tacoma, a majority of the available land has been subjected to some level of development and may be subject to land use requirements in addition to the requirements of this manual.

### **2.2.1 Comprehensive Planning**

The Growth Management Act (GMA) was passed by the Washington Legislature in 1990. The GMA requires fast growing cities to plan for growth through the development of a comprehensive plan. The City of Tacoma Comprehensive Plan is available at [www.cityoftacoma.org/planning](http://www.cityoftacoma.org/planning). The plan sets forth goals, policies and strategies to protect the welfare, safety, and quality of life for Tacoma's residents. The plan includes 26 elements which include items such as housing, utilities, environmental policy, open space, and economic development. The requirements and guidance contained in this manual are consistent with the goals of the comprehensive plan.

Tacoma Municipal Code contains the requirements and regulations that dictate development in the City of Tacoma. Title 13 is the Land Use Regulatory Code. The City of Tacoma Municipal Code can be found here:

[www.cityoftacoma.org/government/city\\_departments/CityAttorney/CityClerk/TMC](http://www.cityoftacoma.org/government/city_departments/CityAttorney/CityClerk/TMC)

## **2.3 Impaired Water Bodies**

Section 305(b) of the Federal Clean Water Act (CWA) requires Ecology to prepare a report every two years on the status of the overall condition of the state's waters. Section 303(d) of the CWA requires Ecology to prepare a list every two years containing water bodies not expected to meet state surface water quality standards after implementation of technology-based controls. The State is then required to complete a Total Maximum Daily Load (TMDL) for all waters on that list. The existing list and other related information is available on Ecology's water quality website:

[http://www.ecy.wa.gov/programs/wq/links/wq\\_assessments.html](http://www.ecy.wa.gov/programs/wq/links/wq_assessments.html)

If a project site discharges to one of these listed waterbodies, additional treatment or flow control requirements may apply.

## **2.4 Floodplains**

Floodplains are not regulated through the Stormwater Management Manual. However, surface water facilities proposed within floodplains will be reviewed on a case-by-case basis to determine if the facilities are acceptable.

Additional analysis and requirements may be needed for surface water facilities located within floodplains.

## **2.5 Tacoma's Watersheds and Other Basins – Summary Descriptions**

### **2.5.1 Flett Creek**

This watershed is 7,153 acres and is the second largest watershed in the City. The area is predominately residential with commercial and light industrial uses in localized areas. The watershed is bordered by Foss Watershed on the east, Leach Creek Watershed on the west and Pierce County to the south. This watershed includes Snake Lake, Wapato Lake, portions of Interstate 5, the South Tacoma Groundwater Protection District and the former South Tacoma Channel Superfund Site.

The east side of the watershed flows through a series of holding ponds known as the Hosmer system, prior to reaching the Flett Creek holding ponds. The Hosmer system consists of the Hosmer holding basin (near South 84<sup>th</sup> Street on the east side of I-5); Ward's Lake (directly across I-5 from Hosmer); and the "Gravel Pit" holding basin (just north of Ward's Lake). In addition to Tacoma's flow contributions, approximately 800 acres of Pierce County flows into the Hosmer Holding Basin. A small tributary area of Lakewood flows into Ward's Lake, and WSDOT has a direct discharge to Ward's Lake which drains the Tacoma Mall, a portion of I-5 and the Wapato Lake area. Wapato Lake is also located in the east side of the watershed and is described in the section below.

The west side of the watershed includes Snake Lake and the South Tacoma Channel Superfund Site. It flows directly into the Flett Creek holding ponds and does not go through the Hosmer system.

Both sides of the Flett Creek Basin drain through the four Flett Creek holding ponds (located in the vicinity of South 85<sup>th</sup> and Tyler Streets) prior to discharge to the Flett wetland and creek. A pump station located at the last Flett Creek holding pond pumps stormwater to the Flett Dairy wetlands from which it drains into Flett Creek.

Flett Creek is approximately 3.0 miles long and is located in the City of Lakewood. The historic headwaters of the creek were located at least partially in Tacoma but were ditched and/or piped long ago. The lower portion of the creek in the City of Lakewood provides for salmonid spawning. Flett Creek flows into Chambers Creek, which is also a salmonid bearing stream, and discharges to the Narrows Passage. There are two fish hatcheries on Chambers Creek.

#### **2.5.1.1 Wapato Lake**

Wapato Lake is a 30-acre urban lake and is the central feature of Wapato Park. This park is an 80-acre facility owned by Metro Parks Tacoma. The surrounding land uses are predominantly residential but include commercial uses and portions of Interstate 5. The lake's valued uses have included recreation (fishing and swimming), wildlife habitat and flood control. Historically, aquatic weed growth, algae blooms, siltation, waterfowl related "swimmers' itch" and other problems have limited the recreational enjoyment of the lake. Currently, the City and Metro Parks are working to improve the lake quality with some success.

In the 1970s, a dike was constructed across the northern portion of the lake and a bypass storm pipe was constructed along its west side. Currently stormwater enters the north cell and exits via the bypass pipe for conveyance to Ward's Lake. During intense storms, stormwater in the north cell will overflow into the main lake; otherwise stormwater is generally bypassed around the lake.

Two major drainage basins (approximately 900 acres total), including stormwater from Interstate 5 discharge into the north cell of the lake. For overflow conditions, there is a stormwater outlet at

the south end of the main lake that is piped to the Ward's Lake holding basin. According to the "Wapato Lake Hydrogeologic Investigation" completed in October 2011, stormwater that is infiltrated within the vicinity of the lake does not significantly contribute recharge to the lake due to the surrounding stormwater system and discontinuity of site soils.

### **2.5.1.2 Snake Lake**

Snake Lake is a 17-acre urban lake and wetland. It is the central feature of the Tacoma Nature Center, a 54-acre facility dedicated to nature education, research and appreciation, operated by Metro Parks Tacoma. Approximately 100,000 people visit the center each year. Valued recreational uses include walking the trails and viewing wildlife. The lake does not support fishing or swimming. Local high schools have been involved in water quality sampling and educational efforts associated with this lake/facility. Also, watershed signs have been posted and catch basins have been stenciled in the associated drainage basin. The City has conducted water quality monitoring and public educational programs in this basin.

The lake drains an urban residential watershed of approximately 584 acres and the associated urban stormwater contributes approximately 80% of the annual flow. Large impervious areas in this drainage basin include Foss High School and a Fred Meyer shopping center. Cheney Stadium was recently retrofitted with a pervious pavement parking lot.

Snake Lake sustains large seasonal fluctuations in its surface area; from 17 acres during wet weather to less than 4 acres during the summer. The water from Snake Lake discharges to the Flett Creek holding basins.

Also located in this drainage basin (northeast of Snake Lake) is the Delong Pond wetland. It currently is an isolated water body (in the past it had a pumped outlet to the storm drainage system). It drains a small tributary area in the basin. The Pierce County Conservations Futures Program purchased part of the wetland and buffer to be preserved as wildlife habitat and open space.

## **2.5.2 Leach Creek**

Tacoma's portion of this watershed covers 1,728 acres and comprises residential and commercial land uses. It is located in the west-central section of Tacoma and is bordered by the Western Slopes and North Tacoma Watersheds to the north, the Flett Creek Watershed to the east, and the Cities of Fircrest and University Place to the southwest. Included in this watershed is a portion of Westgate Shopping Center, James Center, Highland Hills Shopping Center, and Tacoma Community College. A portion of the Tacoma Landfill Superfund site is also included in this watershed. China Lake is also a part of the watershed.

Leach Creek is a little over 2 miles long. Salmonid spawning habitat can be found from Chambers Creek up to Bridgeport Way (the lower portion of the Creek). The upper portions of the Creek also have pockets of spawning grounds; however, the elimination of vegetation and channelization by streamside homeowners and erosion during storm events have impacted these areas. Leach Creek flows into Chambers Creek just downstream of the confluence of Flett and Chambers Creek. Chambers Creek is a fish bearing creek and there are two fish hatcheries located on the creek.

### **2.5.2.1 Leach Creek Holding Basin**

Stormwater within the watershed is piped to the Leach Creek Holding Basin (near S 35<sup>th</sup> & Orchard St.), which discharges into Leach Creek, a highly urbanized stream. WSDOT and the cities of Tacoma, Fircrest and University Place discharge to the holding basin.

The Leach Creek Holding Basin was constructed by the City of Tacoma in 1961. In 1991, the City completed major improvements to the Leach Creek Holding Basin. During heavy rainfall events, stormwater is pumped from the holding basin into the Thea Foss Waterway to avoid sending high flows to Leach Creek.

### **2.5.3 Northeast Tacoma**

This watershed covers 2,641 acres and consists primarily of residential development with open spaces. The area borders Commencement Bay and the Tideflats Watershed on the west. Many steep bluffs are located between the uplands areas, Commencement Bay and the Hylebos Waterway. Pierce County and the City of Federal Way border the area to the north and east. The City of Fife is located to the south.

Most of the stormwater from this watershed is discharged directly into Commencement Bay or the Hylebos Waterway. Some stormwater is discharged to Dry Gulch – an intermittent stream that discharges to Puget Sound through unincorporated Pierce County. A capital improvement project was completed in Dry Gulch in 1993 to control flooding and associated erosion and sediment problems.

### **2.5.4 Joe's Creek**

This watershed covers 157 acres and is the smallest of the City's nine watersheds. It is bordered on the north and east by Pierce County and the City of Federal Way, respectively. The area is comprised of single and multiple-family residential land uses with some open space and undeveloped land. Most of Joe's Creek is located in Federal Way. Drainage in this area discharges to Federal Way and eventually to Puget Sound at Dumas Bay. Joe's Creek is utilized by salmonids.

### **2.5.5 North Tacoma**

This watershed covers 4,766 acres and is located in the northern portion of Tacoma. The area includes the east side of Point Defiance Park extending to North 30th and Pearl Street, and the area from approximately 6th Avenue and Stevens Street to Commencement Bay. The area is predominantly residential in nature with some commercial areas such as the 6th Avenue District, the Proctor District and Ruston Way. It also contains the North End Wastewater Treatment Plant and the former ASARCO Smelter site. The nearshore area along Commencement Bay north to the former ASARCO copper smelting site has been designated as part of the Commencement Bay Nearshore/Tideflats Superfund Site. This area is currently being remediated and redeveloped. Steep slopes are located along the northern edge of the watershed.

Water bodies within this watershed include Commencement Bay, Ruston Creek, Asarco Creek, Puget Creek, Mason Creek and the stream associated with Garfield Gulch. Puget Creek, Mason Creek and Garfield Creek are all regularly monitored as part of the City's creek monitoring program. Puget and Mason Creeks are perennial and have steep slopes associated with them.

#### **2.5.5.1 Puget Creek**

Puget Creek passes through an underground fish ladder/culvert, and combines with the city's stormwater system to pass under Ruston Way just upstream of its discharge point to Commencement Bay. Several community groups have worked to reintroduce salmon to Puget Creek by improving fish access and vegetative cover in Puget Creek. A fish ladder was installed in 1997 to provide fish access to the creek. The majority of stormwater discharges are piped through the gulch via a 42" pipe protecting Puget Creek from erosion during high flow events.

### **2.5.6 Thea Foss Waterway**

This watershed covers approximately 5,751 acres and is comprised of drainage basins located in the south-central portion of Tacoma. The area borders the North Tacoma Watershed on the north, the Flett Watershed on the west and south, and the Tideflats and Lower Puyallup Watersheds on the east. The area extends as far south as 86th Street and also includes portions of the tideflats (including Middle and St. Paul Waterway) on the east side of Foss Waterway. Land use is predominantly residential, although most of Tacoma's commercial businesses are located in this watershed. There are some industrial uses, concentrated mainly in the tideflats and Nalley Valley portions of the watershed. The Thea Foss Waterway is part of the Commencement Bay/Nearshore Tideflats Superfund site. Cleanup efforts were completed in 2006. The City continues to monitor sediment and stormwater discharges from this watershed.

### **2.5.7 Tideflats**

This watershed covers 2,112 acres and is the most highly industrialized and commercialized portion of the City. The majority of the City's heavy industrial facilities are located here. The area is bordered by the Lower Puyallup Watershed on the west, Northeast Tacoma to the east and Commencement Bay and the City of Fife to the north and south, respectively. Included in this watershed are the Sitcum, Blair, and Hylebos Waterways and Hylebos and Wapato Creeks. The Milwaukee Waterway was filled and capped during 1993-1995.

### **2.5.8 Lower Puyallup**

This watershed covers 2,971 acres and is located in the southeast portion of Tacoma. The area borders the Foss Waterway Watershed on the west and the Tideflats Watershed and Pierce County on the east, and funnels north along the Puyallup River. The southern portion of the watershed is predominantly residential with some undeveloped open space and a few small commercial areas. Included in this watershed are Interstate 5 from Fife to the Tacoma Dome, Salishan, Portland Avenue, the First Creek area, and the area east of the Tacoma Dome. The northern portion of the watershed consists of industrial and commercial areas. Water bodies within this watershed include the Puyallup River, Swan Creek and First Creek.

#### **2.5.8.1 Puyallup River**

The Puyallup River is of area-wide significance. The associated drainage basin occupies approximately 972 square miles in the Puget Lowlands. Its two major tributaries are the White and Carbon Rivers which contribute 50% and 30% of the Puyallup River flow, respectively. The lower portion of the river from its mouth to approximately two miles upstream is located within the City of Tacoma. The lower Puyallup at Commencement Bay is a salt-wedge estuary, with deeper marine water overlain by a layer of fresh water. This estuary has been extensively modified, losing up to 99% of its estuarine wetland area. Habitat restoration efforts have resulted in increased wetland acreage. Below River Mile 2.0 in the tideflats area, industrial activity is dominant. The river, along with its tributaries, serve as major migration routes for a variety of salmonids, including Spring Chinook, Steelhead and Bull Trout which have all been listed as endangered species. There are four fish hatcheries located in this system upstream of Tacoma.

#### **2.5.8.2 Swan Creek**

Swan Creek originates in Pierce County south of Highway 512. It flows north towards the Puyallup River and along the City of Tacoma-Pierce County boundary. It enters a narrow canyon at approximately creek mile three and leaves the canyon just upstream of Pioneer Road (approximately creek mile 0.5). The creek then flows north then east to its confluence with Clear

Creek. Clear Creek then flows into the Puyallup River. This discharge point is located in unincorporated Pierce County. This creek is used by salmonids.

The Swan Creek drainage basin is large, encompassing hundreds of acres. Most of the area is located in unincorporated Pierce County. A small portion of the basin lies along the City of Tacoma's eastern border. Much of the land located within the lower portion of the drainage basin is located within Swan Creek Park, which is owned and operated by Metro Parks Tacoma. The City restored a large habitat site near the mouth of Swan Creek through the Natural Resource Damages Assessment Program (NRDA). Stream Team volunteers monitor water quality in Swan Creek for the City.

### **2.5.8.3 First Creek (formerly T-Street Gulch)**

The First Creek drainage basin encompasses approximately 2,500 acres of residential/commercial area. The majority of the basin is within the City of Tacoma, although approximately 600 acres lie within unincorporated Pierce County.

### **2.5.9 Western Slopes Watershed**

This watershed covers 2,090 acres, is located in the northwest portion of Tacoma and drains to the Tacoma Narrows. The watershed borders the North Tacoma Watershed and Leach Creek Watershed on the east and the Tacoma Narrows on the west. With the exception of the west end of 6th Avenue, Titlow Park, and a portion of Point Defiance Park, the area is predominantly residential with many steep slopes. Residential development continues in this area. Underground springs and near surface groundwater are characteristic of the steep slopes in this area. There are several small creeks in this area. They are Gold Creek, Narrows Creek, Crystal Creek, Crystal Springs Creek, Marinera Creek and Titlow Park Gulch Creek. There are also some gulch/creek systems that have very little flow.

### **2.5.10 South Tacoma Groundwater Protection District**

In 1985, the City of Tacoma adopted the South Tacoma Plan which formally designates the South Tacoma Groundwater Protection District (STGPD) as an "environmentally sensitive" area (see Figure 1 - 2). The plan specifically listed several action steps designed to protect the South Tacoma Aquifer which is used as a drinking water supply for the City of Tacoma. One of the steps mandated that a local groundwater protection program be developed for the STGPD. The ordinance is set out in Tacoma Municipal Code Chapters 13.09.010 through 13.09.200.

The purpose of the STGPD is to stop potential pollution problems before they create environmental contamination. This program is administered by the Tacoma-Pierce County Health Department (TPCHD) in coordination with Environmental Services, Tacoma Water and the Tacoma Fire Department. TPCHD is responsible for reviewing, authorizing, and issuing permits for business and industrial operations that are regulated under the program. TPCHD staff also performs site inspections. However, the City of Tacoma Environmental Services is responsible for the review and approval of all stormwater and wastewater plans. Private infiltration facilities systems used in the STGPD that receive stormwater from pollution-generating surfaces may be allowed on a case-by-case basis and are subject to additional treatment and monitoring.

The City of Tacoma Public Works Department and Tacoma-Pierce County Health Department developed a guidance document that provides the circumstances and requirements for approval of infiltration facilities for managing pollution-generating stormwater runoff in the STGPD. The document, "Implementation of Stormwater Infiltration for Pollution-Generating Surfaces in the

South Tacoma Groundwater Protection District” is available as Volume 5, Appendix D and at [www.cityoftacoma.org/stormwatermanual](http://www.cityoftacoma.org/stormwatermanual) under Stormwater Policy Updates.

### **2.5.11 Sensitive Habitat Areas**

Natural Resource Damage Assessment (NRDA) areas and other sensitive habitat areas are shown in Figure 1 - 3 and Figure 1 - 4. These sites may require a higher level of stormwater mitigation. Typically, enhanced treatment is required for projects that meet or exceed the threshold for water quality treatment and discharge to sensitive habitat areas. Additional water quality treatment may be required on a case-by-case basis. Contact Environmental Services for more information on these and other sensitive habitat sites.



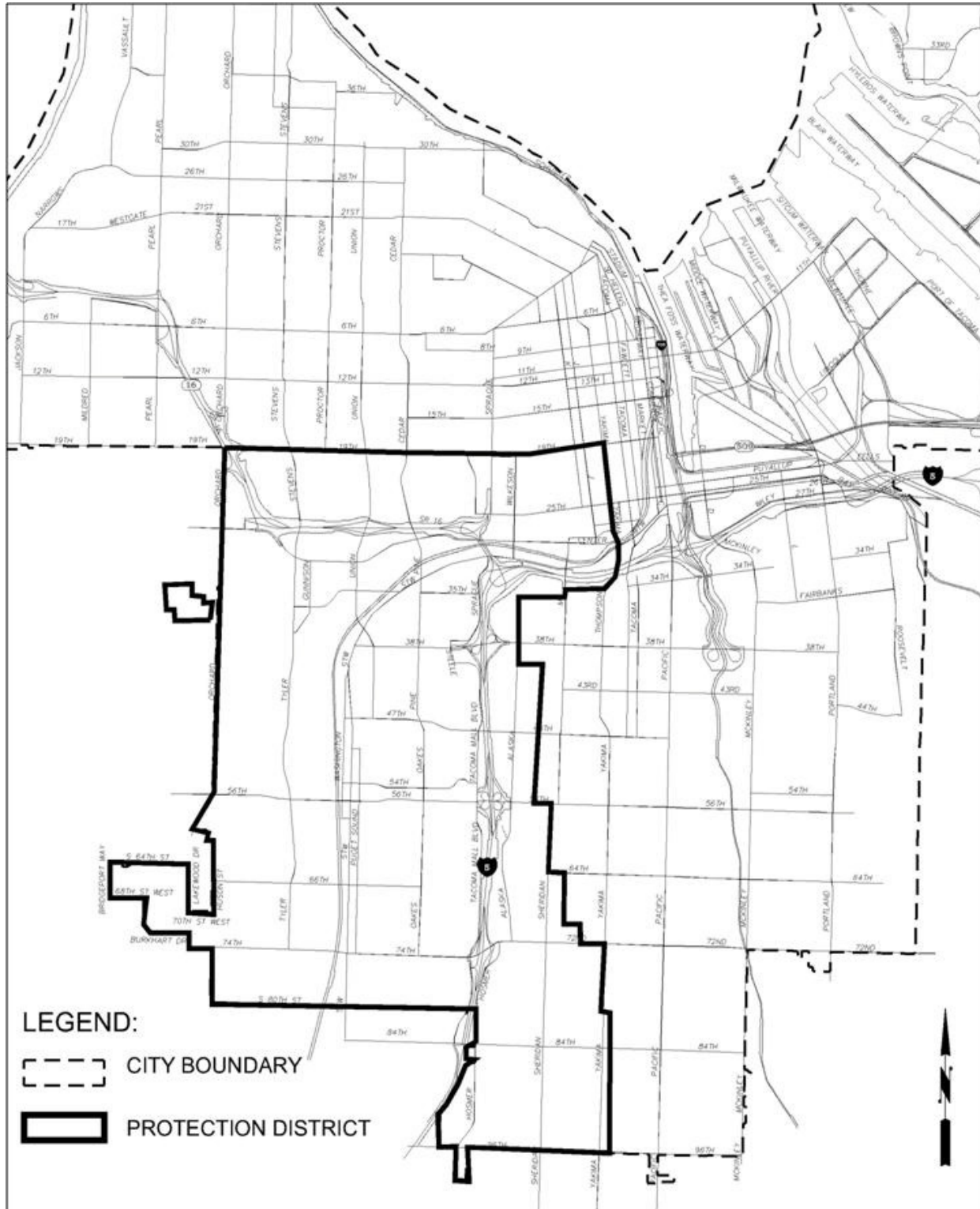
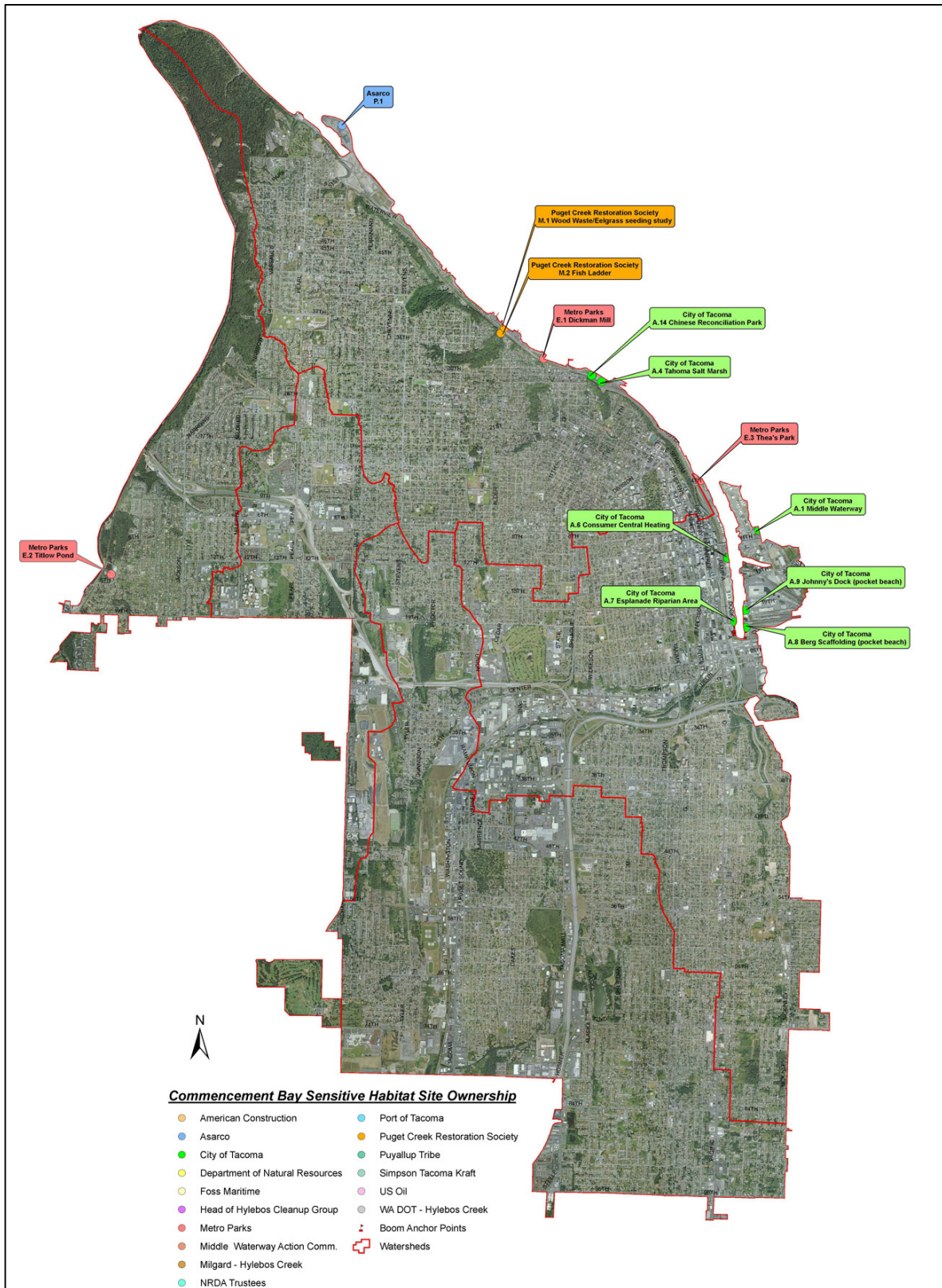


Figure 1 - 2. South Tacoma Groundwater Protection District (STGPD)



**Figure 1 - 3. NRDA Areas and Sensitive Habitat Sites (West Tacoma Area)**

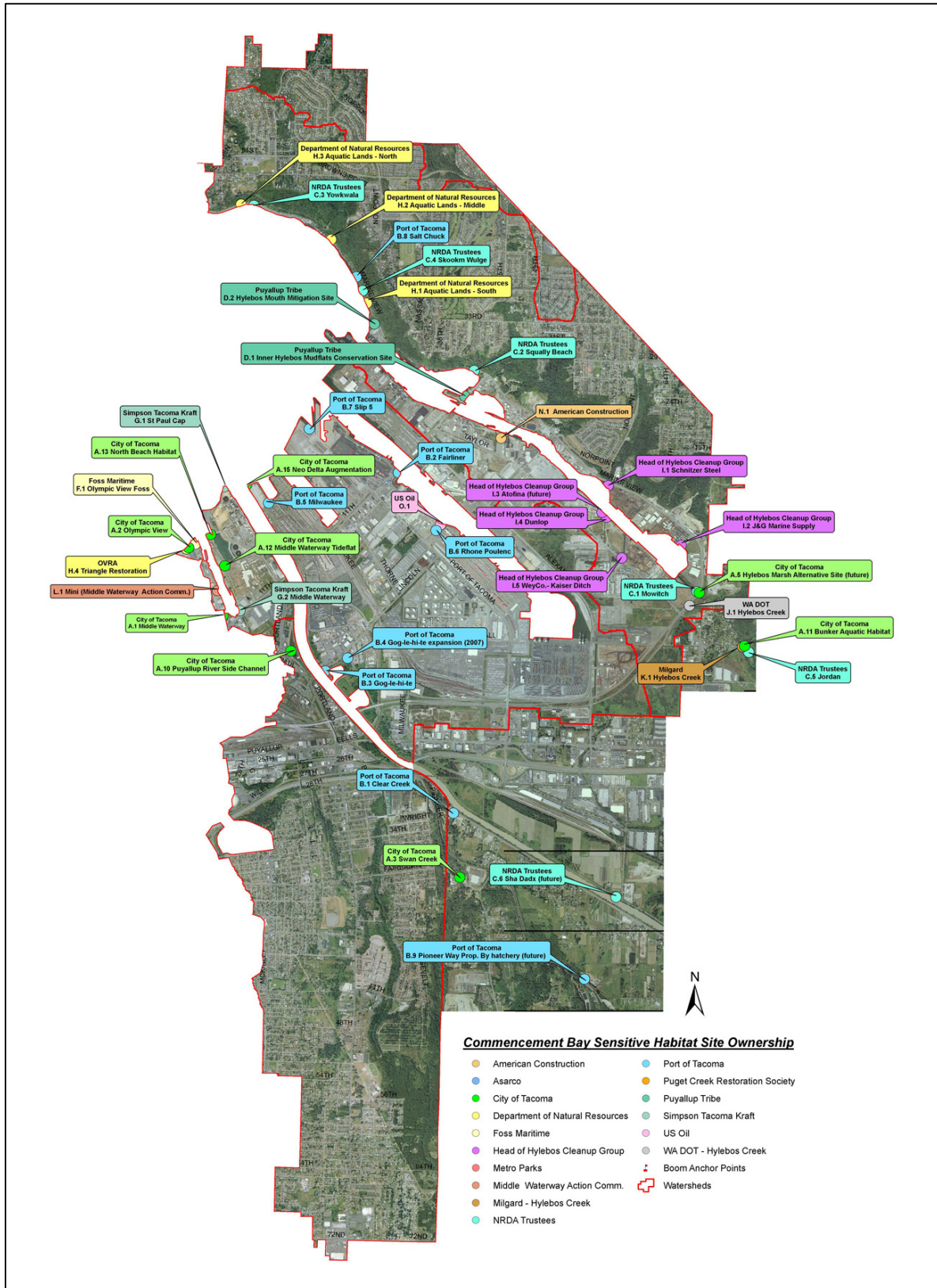


Figure 1 - 4. NRDA Areas and Sensitive Habitat Sites (East Tacoma Area)

## **Chapter 3 Minimum Requirements for New Development and Redevelopment**

This Chapter identifies the Minimum Requirements for stormwater management applicable to new development and redevelopment sites. These requirements are codified in Chapter 12.08 of the Tacoma Municipal Code (TMC). New development and redevelopment projects also may be subject to other City code requirements, depending on the nature and location of the project.

The City of Tacoma Municipal Code can be found:

[http://www.cityoftacoma.org/government/city\\_departments/CityAttorney/CityClerk/TMC/](http://www.cityoftacoma.org/government/city_departments/CityAttorney/CityClerk/TMC/)

### **3.1 Overview of the Minimum Requirements**

The Minimum Requirements are:

1. Preparation of Stormwater Site Plans
2. Construction Stormwater Pollution Prevention
3. Source Control of Pollution
4. Preservation of Natural Drainage Systems and Outfalls
5. Onsite Stormwater Management
6. Runoff Treatment
7. Flow Control
8. Wetlands Protection
9. Operation and Maintenance

The City also has one additional requirement beyond those required in Ecology's 2012 manual:

10. Offsite Analysis and Mitigation

Depending on the type and size of the proposed project, different combinations of these Minimum Requirements apply.

Section 3.4 provides additional information on applicability of the Minimum Requirements.

This manual is designed to be equivalent to Ecology's 2012 Stormwater Management Manual for Western Washington. Ecology considers its manual to include all known, available and reasonable methods of prevention, control, and treatment (AKART). Ecology's manual has no independent regulatory authority. However, Ecology requires, as a condition of the National Pollutant Discharge Elimination System (NPDES) Phase I Municipal Stormwater Permit, the adoption of site and subdivision requirements including those Minimum Requirements contained in the permit.

The Minimum Requirements of this Chapter are conditions of the City's stormwater NPDES permit, and are required under Tacoma's Municipal Code, Chapter 12.08.090 *Stormwater Program Requirements*.

### **3.2 Exemptions**

The following are exempt from complying with the Minimum Requirements. All other new development or redevelopment projects are subject to one or more of the Minimum Requirements (see Section 3.4).

### 3.2.1 Pavement Maintenance

The following pavement maintenance practices are exempt:

- Pothole and square cut patching
- Overlaying existing asphalt or concrete pavement with asphalt or concrete without expanding the area of coverage (overlaying permeable or pervious pavements with traditional (non-permeable) asphalt or pavement is not considered pavement maintenance)
- Shoulder grading
- Reshaping/regrading drainage systems
- Crack Sealing
- Resurfacing with in-kind material without expanding the road prism
- Pavement preservation activities that do not expand the road prism
- Vegetation maintenance
- Catch basin and pipe maintenance

The following pavement maintenance practices are not exempt. The practices are subject to the Minimum Requirements that are triggered when the thresholds are met or exceeded. The extent to which the manual applies is explained for each circumstance.

The following affected surfaces are considered replaced hard surfaces:

- Removing and replacing a paved surface to base course or lower, or repairing the roadway base.

The following affected surfaces are considered new hard surfaces:

- Extending the pavement edge without increasing the size of the road prism,
- Paving graveled shoulders,
- Resurfacing by upgrading from dirt to gravel, asphalt, or concrete,
- Resurfacing by upgrading from gravel to asphalt or concrete; or
- Resurfacing by upgrading from a bituminous surface treatment to asphalt or concrete.

Parking lot and road surfacing requirements are regulated through the Tacoma Municipal Code – Title 2 (Buildings), Title 10 (Public Works), Title 13 (Land Use Regulatory Code) and the Public Works Design Manual. No special considerations will be given to “temporary” pavement surfaces (e.g., parking lots, roads) as the impacts resulting from the proposed hard surface must be mitigated as part of construction.

### 3.2.2 Underground Utility Projects

Underground utility projects that replace the ground surface with in-kind material or materials with similar runoff characteristics are only subject to Minimum Requirement #2, Construction Stormwater Pollution Prevention.

### 3.2.3 Minor Clearing and Grading

The following minor clearing and grading activities are only subject to Minimum Requirement #2; unless located within a critical or sensitive area governed by the City’s Critical Areas Preservation Ordinance. The location of Critical Areas can be found on the City’s GovME website located at: [www.govme.org](http://www.govme.org).

- Excavation for wells, except fill composed of the material from such excavation shall not be exempt;
- Exploratory excavations under the direction of soil engineers or engineering geologists, except fill composed of the material from such excavation shall not be exempt;
- Removal of hazardous trees;
- Removal of trees or other vegetation which cause sight distance obstructions at intersections as determined by the City of Tacoma traffic engineer;
- Minor clearing and grading associated with cemetery graves;
- Land clearing associated with routine maintenance by public utility agencies, as long as appropriate vegetation management practices are followed as described in the Best Management Practices of the Regional Road Maintenance Endangered Species Act Program Guidelines located at <http://www.wsdot.wa.gov/maintenance/roadside/esa.htm>

### **3.2.4 Emergencies**

Emergency projects which, if not performed immediately would substantially endanger life or property, are exempt only to the extent necessary to meet the emergency. Emergency activities may include but are not limited to: sandbagging, diking, ditching, filling or similar work during or after periods of extreme weather. Permits authorizing the emergency work may be required after completion of the emergency project.

### **3.3 Applicability of the Minimum Requirements**

The Minimum Requirements shall apply to all applications submitted after January 7, 2016; and all applications submitted on or before January 7, 2016, which have not started construction by January 7, 2021. In this context, “started construction” means, at a minimum, the site work associated with, and directly related to the approved project has begun (e.g. grading to final grade or utility installation). Simply clearing the project site does not constitute as “started construction”.

Not all of the Minimum Requirements apply to every development or redevelopment project. The applicability varies depending on the type and size of the project. This section identifies thresholds that determine the applicability of the Minimum Requirements to different projects. The thresholds shall be determined using the proposed improvements for the entire project site.

The Minimum Requirements shall be based on the most sensitive receiving waterbody along the discharge route and upon final discharge location. Environmental Services shall make the final determination of the applicability of the Minimum Requirements.

The flow charts in Figure 1 - 5 to Figure 1 - 9 are intended as guidance for determining Minimum Requirements. The figures do not provide a complete analysis of each Minimum Requirement. The applicant must review Volume 1, Section 3.3.1 – New Development, Volume 1, Section 3.3.2 – Redevelopment and the text of each Minimum Requirement to determine stormwater mitigation requirements for their project. The written text shall take precedence over the flowcharts.

### 3.3.1 New Development

All new development shall be required to comply with Minimum Requirement #2. Minimum Requirement #9 may apply to any project where a permanent stormwater facility exists or is proposed to be constructed. Minimum Requirement #10 may apply to projects that increase the amount of stormwater runoff to the downstream stormwater system.

The following new development shall comply with Minimum Requirements #1 through #5 for the new and replaced hard surfaces and the land disturbed:

- Results in 2,000 square feet, or greater, of new, replaced, or new plus replaced hard surface area, or
- Has land disturbing activity of 7,000 square feet or greater.

The following new development shall comply with Minimum Requirements #1 through #10 for the new and replaced hard surfaces and the converted vegetation areas.

- Results in 5,000 square feet, or greater, of new plus replaced hard surface area, or
- Converts  $\frac{3}{4}$  acres, or more, of vegetation to lawn or landscaped areas, or
- Converts 2.5 acres, or more, of native vegetation to pasture.

### 3.3.2 Redevelopment

Redevelopment is development on a site that is already substantially developed (i.e. has 35% or more existing hard surface coverage).

To encourage redevelopment projects, replaced surfaces aren't required to be brought up to new stormwater standards unless the monetary or space thresholds noted in this section are exceeded.

All redevelopment shall be required to comply with Minimum Requirement #2. Minimum Requirement #9 may apply to any project regardless of size where a permanent stormwater facility exists or is proposed to be constructed. Minimum Requirement #10 may apply to projects that increase the amount of stormwater runoff to the downstream stormwater system.

The following redevelopment shall comply with Minimum Requirements #1 through #5 for the new and replaced hard surfaces and the land disturbed:

- Results in 2,000 square feet or greater of new, replaced, or total of new plus replaced hard surface area, or
- Has land disturbing activity of 7,000 square feet or greater.

In addition to meeting Minimum Requirements #1 through #5, the following redevelopment shall comply with Minimum Requirements #6 through #10 for the new hard surfaces and converted vegetation areas:

- Adds 5,000 square feet or more of *new* hard surfaces or,
- Converts  $\frac{3}{4}$  acres, or more, of vegetation to lawn or landscaped areas, or
- Converts 2.5 acres, or more, of native vegetation to pasture.

In addition to meeting Minimum Requirements #1 through #10 for the *new* and *converted* surfaces, the following shall comply with all the Minimum Requirements for the *new* and *replaced* hard surfaces and *converted* vegetation areas:

- The total of new plus replaced hard surfaces is 5,000 square feet or more and the valuation of the proposed improvements (materials plus labor to construct) - including interior improvements - exceeds 50% of the assessed value of the existing site improvements as determined from the latest available building valuation data published by the International Code Council, available at <http://www.iccsafe.org/>.

The Building Valuation Data provided by the International Code Council may not include all improvements that can occur on a site. All site improvements must be included when determining if the improvements exceed 50% of the assessed value. These might include improvements such as parking lots, driveways, sport courts, swimming pools, etc. in addition to the valuation of any proposed or existing buildings.

### **3.3.2.1 Roads and Redevelopment**

In addition to meeting Minimum Requirements #1 through #10 for the new and converted surfaces, the following road-related redevelopment projects shall comply with all the Minimum Requirements for the new and replaced hard surfaces and converted vegetation areas:

The total of the new hard surfaces is 5,000 square feet or more and total 50% or more of the existing hard surfaces within the project limits.

See Figure 1 - 7. Determining the Minimum Requirements for Road-Related Projects

The project limits shall be defined by the length of the project and the width of the right-of-way. Public road improvements (offsite improvements) required as part of a private development project will be considered part of the project site used for determining the project thresholds of the private project and shall not be considered road-related projects.

The following road maintenance practices are subject to the Minimum Requirements that are triggered when the thresholds are met. The extent to which the manual applies is explained for each circumstance.

The following affected surfaces would be considered replaced hard surfaces:

- Removing and replacing a paved surface to base course or lower, or repairing the roadway base.

The following affected surfaces would be considered new hard surfaces:

- Extending the pavement edge without increasing the size of the road prism;
- Paving graveled shoulders;
- Resurfacing by upgrading from dirt to gravel, asphalt, or concrete
- Resurfacing by upgrading from gravel to asphalt or concrete; or
- Resurfacing by upgrading from a bituminous surface treatment to asphalt or concrete.

### **3.3.3 Equivalent Areas**

The City may allow the Minimum Requirements to be applied to equivalent areas (flow and pollution characteristics). Environmental Services shall approve the use of equivalent areas.

Minimum Requirements may be applied to an equivalent area within the same project site that drains to the same receiving water. For the portion of the project within the City Right-of-Way or for road-related projects, the equivalent area does not have to be located within the project limits but must drain to the same receiving water.



### **3.3.4 Cumulative Impact Mitigation Requirement and Vesting**

The determination of thresholds for a project shall be based on the total increase or replacement of hard surfaces that occurred after adoption of the 2003 SWMM (January 1, 2003).

Under this provision, the City will consider the cumulative impacts of all hard surfaces constructed on or after January 1, 2003. The combined total of new or replaced surfaces will be applied to the thresholds that determine applicability of the Minimum Requirements.

The Minimum Requirements shall apply to all projects submitted after January 7, 2016; and all projects approved prior to January 7, 2016, which have not started construction by January 7, 2021. In this context, “started construction” means, at a minimum, the site work associated with, and directly related to the approved project has begun (e.g. grading to final grade or utility installation). Simply clearing the project site does not constitute as “started construction”.

The intent of this Cumulative Impact Mitigation Requirement is to adequately mitigate the stormwater from improvements on a project site that are submitted under separate permits. The separate submittals could have project areas that do not meet the thresholds, but would meet the thresholds if the projects were combined as one project.

### **3.3.5 Grade and Fill Projects**

For the purpose of this manual grade and fill projects are those projects that do not include clearing or adding or replacing hard surfaces. Grade and fill projects require stormwater pollution prevention during grading and filling to protect downstream systems.

Projects grading/filling greater than 50 cubic yards of material are required to submit a Construction Stormwater Pollution Prevention Plan (SWPPP) per Volume 2 of this manual. Projects grading/filling between 50 and 499 cubic yards of material may submit a short form SWPPP as outlined in Volume 2, Appendix B. Projects grading/filling 500 cubic yards or more of material are required to submit a long form SWPPP per Volume 2.

### **3.3.6 Separation of Public and Private Water Quality and Flow Control**

Typically, private and public stormwater are separated for purposes of water quality treatment and flow control. However, the City recognizes that this is not always practical. Therefore, the City has developed the following guidance:

- For commercial new development and redevelopment, typically public and private stormwater runoff shall be separated. The City may allow incidental amounts of private stormwater runoff to enter the City system with written approval from Environmental Services.
- Under certain circumstances, incidental amounts of public stormwater may be allowed to discharge to private flow control systems with written approval from Environmental Services. A written agreement between the City and owner and Notice to Title may be required.
- For residential new development and redevelopment, for areas adjacent to public roads, such as driveways, the City will typically allow driveway runoff to drain to the street if onsite management is not feasible and the amount of driveway area is small compared to the public road area. Written approval from Environmental Services is required. Private accessway runoff shall be handled in separate private water quality and/or flow control facilities.

### 3.3.7 Watershed Specific Requirements

The stormwater requirements outlined in Volume 1, Chapter 3 typically apply to all new development and redevelopment projects meeting the thresholds regardless of watershed. The following sections describe briefly the requirements that would typically apply within each watershed if the thresholds for the specific Minimum Requirements are met. Minimum Requirement #8 – Wetlands Protection may be applicable in any watershed. See Volume 1, Chapter 3 to determine which Minimum Requirements apply to a project. See Volume 5 to determine the required type of water quality treatment.

The requirements of this manual can be superseded or modified by the adoption of policies, ordinances and rules to implement the recommendations of watershed plans or basin plans or by changes in requirements, procedures, or policies.

The applicant is directed to the City's webpage for SWMM updates: [www.cityoftacoma.org/stormwatermanual](http://www.cityoftacoma.org/stormwatermanual).

#### 3.3.7.1 Flett Creek

In the Flett Creek watershed, stormwater typically discharges to freshwater bodies designated for aquatic life use or that have an existing aquatic life use.

##### 3.3.7.1.1 Typical Requirement

MR #5 Onsite Stormwater Management (Vol. 1, Sec. 3.4.5) (one of the following depending on project scope):

- List #1 or List #2
- OR
- Low Impact Development Performance Standard

MR #6 - Water Quality (Vol. 1, Sec. 3.4.6) (one or more of the following depending on project scope):

- Basic, enhanced, and/or oil control.
- Phosphorus treatment required only for discharges to Wapato Lake except those projects that infiltrate stormwater.
- South Tacoma Groundwater Protection District specific requirements: See Volume 1, Section 2.5.10.

MR #7 - Flow Control (Vol. 1, Sec 3.4.7):

- Standard Requirement – Forested Condition.

##### 3.3.7.1.2 Special Considerations

Snake Lake is classified as a wetland. Projects that discharge stormwater directly or indirectly into Snake Lake and meet the thresholds shall comply with Minimum Requirement #8. Some projects may be subject to the Critical Areas Preservation Ordinance. Additional or different requirements may be imposed by other City of Tacoma departments.

Portions of the Flett Creek watershed discharge to adjacent municipalities. In these cases, the more stringent requirements between the City of Tacoma Stormwater Management Manual and the receiving municipality will be applied for determining stormwater mitigation requirements.

### 3.3.7.2 Leach Creek

In the Leach Creek watershed, stormwater typically discharges to freshwater bodies designated for aquatic life use or have an existing aquatic life use.

#### 3.3.7.2.1 Typical Requirement

MR #5 (Vol. 1, Sec. 3.4.5) - Onsite Stormwater Management (one of the following depending on project scope):

- List #1 or List #2
- OR
- Low Impact Development Performance Standard

MR #6 - Water Quality (Vol. 1, Sec. 3.4.6) (one or more of the following depending on project scope):

- Basic, enhanced, and/or oil control.
- South Tacoma Groundwater Protection District specific requirements: See Volume 1, Section 2.5.10.

MR #7 (Vol. 1, Sec 3.4.7) - Flow Control:

- Standard Requirement – Forested Condition.

#### 3.3.7.2.2 Special Considerations

Portions of the Leach Creek watershed discharge to adjacent municipalities. In these cases, the more stringent requirements between the City of Tacoma Stormwater Management Manual and the receiving municipality will be applied for determining stormwater mitigation requirements.

### 3.3.7.3 Northeast Tacoma

In the Northeast Tacoma watershed, stormwater typically discharges to marine waters though discharges to wetlands, freshwater bodies, and gulches may be possible.

#### 3.3.7.3.1 Typical Requirement

MR #5 (Vol. 1, Sec. 3.4.5) - Onsite Stormwater Management (one of the following depending on project scope and discharge location):

- Marine Waterbodies
- List #1, List #2, or Low Impact Development Performance Standard

MR #6 - Water Quality (Vol. 1, Sec. 3.4.6) (one or more of the following depending on project scope and discharge location):

- Basic, enhanced, and/or oil control.
- Enhanced treatment is required for projects discharging to sensitive habitat sites (see Figure 1 - 3 and Figure 1 - 4 for locations).

MR #7 (Vol. 1, Sec 3.4.7) - Flow Control (one of the following depending on final discharge location):

- Infrastructure Protection
- Standard Requirement – Forested Conditions (discharges to freshwater bodies).

### **3.3.7.3.2 Special Considerations**

Portions of the Northeast Tacoma watershed discharge to adjacent municipalities. In these cases, the more stringent requirements between the City of Tacoma Stormwater Management Manual and the receiving municipality will be applied for determining stormwater mitigation requirements.

### **3.3.7.4 Joe's Creek**

In the Joe's Creek watershed, stormwater typically discharges to freshwater bodies designated for aquatic life use or have an existing aquatic life use.

#### **3.3.7.4.1 Typical Requirement**

MR #5 (Vol. 1, Sec. 3.4.5) - Onsite Stormwater Management (one of the following depending on project scope and discharge location):

- List #1 or List #2
- OR
- Low Impact Development Performance Standard

MR #6 - Water Quality (Vol. 1, Sec. 3.4.6) (one or more of the following depending on project scope and discharge location):

- Basic, enhanced, and/or oil control.

MR #7 (Vol. 1, Sec 3.4.7) - Flow Control:

- Standard Requirement – Forested Conditions.

#### **3.3.7.4.2 Special Considerations**

Portions of the Joe's Creek watershed discharge to adjacent municipalities. In these cases, the more stringent requirements between the City of Tacoma Stormwater Management Manual and the receiving municipality will be applied for determining stormwater mitigation requirements.

### **3.3.7.5 North Tacoma**

In the North Tacoma watershed, stormwater typically discharges to marine waters though discharges to wetlands, freshwater bodies, and gulches may be possible.

#### **3.3.7.5.1 Typical Requirement**

MR #5 (Vol. 1, Sec. 3.4.5) - Onsite Stormwater Management (one of the following depending on project scope and discharge location):

- Marine Waterbodies
- List #1, List #2, or Low Impact Development Performance Standard

MR #6 (Vol. 1, Sec. 3.4.6) - Water Quality (one or more of the following depending on project scope and discharge location):

- Basic, enhanced, and/or oil control.
- Enhanced treatment is required for projects discharging to sensitive habitat sites (see Figure 1 - 3 and Figure 1 - 4 for locations).

MR #7 (Vol. 1, Sec 3.4.7) - Flow Control (one of the following depending on final discharge location):

- Infrastructure Protection

- Standard Requirement – Existing Conditions (discharges to freshwater bodies or gulches).

### **3.3.7.6 Thea Foss Watershed**

In the Thea Foss watershed, stormwater typically discharges to marine waters though discharges to wetlands, freshwater bodies, and gulches may be possible.

#### **3.3.7.6.1 Typical Requirement**

MR #5 (Vol. 1, Sec. 3.4.5) - Onsite Stormwater Management (one of the following depending on project scope and discharge location):

- Marine Waterbodies
- List #1, List #2, or Low Impact Development Performance Standard

MR #6 (Vol. 1, Sec. 3.4.6) - Water Quality (one or more of the following depending on project scope and discharge location):

- Basic, enhanced, and/or oil control.
- Enhanced treatment is required for projects discharging to sensitive habitat sites (see Figure 1 - 3 and Figure 1 - 4 for locations).
- South Tacoma Groundwater Protection District specific requirements: See Volume 1, Section 2.5.10.

MR #7 (Vol. 1, Sec 3.4.7) - Flow Control (one of the following depending on final discharge location):

- Infrastructure Protection
- Standard Requirement – Existing Conditions (discharges to freshwater bodies).

### **3.3.7.7 Tideflats Watershed**

In the Tideflats watershed, stormwater typically discharges to marine waters though discharges to wetlands, freshwater bodies, and gulches may be possible.

#### **3.3.7.7.1 Typical Requirement**

MR #5 (Vol. 1, Sec. 3.4.5) - Onsite Stormwater Management (one of the following depending on project scope and discharge location):

- Marine Waterbodies
- List #1, List #2, or Low Impact Development Performance Standard

MR #6 (Vol. 1, Sec. 3.4.6) - Water Quality (one or more of the following depending on project scope and discharge location):

- Basic, enhanced, and/or oil control.
- Enhanced treatment is required for projects discharging to sensitive habitat sites (see Figure 1 - 3 and Figure 1 - 4 for locations).

MR #7 (Vol. 1, Sec 3.4.7) - Flow Control (one of the following depending on final discharge location):

- Infrastructure Protection
- Standard Requirement – Existing Conditions (discharges to freshwater bodies or gulches).

### **3.3.7.8 Lower Puyallup Watershed**

In the Lower Puyallup watershed, stormwater discharges to the Puyallup River before discharging to marine waters. Swan Creek and First Creek are located in the Lower Puyallup watershed.

#### **3.3.7.8.1 Typical Requirement**

MR #5 (Vol. 1, Sec. 3.4.5) - Onsite Stormwater Management (one of the following depending on project scope and discharge location):

- Marine Waterbodies
  - The Puyallup River and First Creek are considered flow control exempt waterbodies.
- List #1, List #2, or Low Impact Development Performance Standard

MR #6 (Vol. 1, Sec. 3.4.6) - Water Quality (one or more of the following depending on project scope and discharge location):

- Basic, enhanced, and/or oil control.
- Enhanced treatment is required for projects discharging to sensitive habitat sites (see Figure 1 - 3 and Figure 1 - 4 for locations).
- The Puyallup River is considered a basic treatment waterbody. Enhanced treatment is not required for discharges to the Puyallup River.

MR #7 (Vol. 1, Sec 3.4.7) - Flow Control (one of the following depending on final discharge location):

- Infrastructure Protection
- Standard Requirement – Existing Conditions (discharges to freshwater bodies).
- Standard Requirement – Forested Condition required for discharges to Swan Creek.
- The Puyallup River and First Creek are considered flow control exempt waterbodies and shall comply with the Flow Control Exempt Waterbody requirements of Volume 1, Section 3.4.7.3.2.

### **3.3.7.9 Western Slopes Watershed**

In the Western Slopes watershed, stormwater typically discharges to marine waters though discharges to wetlands, freshwater bodies, and gulches may be possible.

#### **3.3.7.9.1 Typical Requirement**

MR #5 (Vol. 1, Sec. 3.4.5) - Onsite Stormwater Management (one of the following depending on project scope and discharge location):

- Marine Waterbodies
- List #1, List #2, or Low Impact Development Performance Standard

MR #6 (Vol. 1, Sec. 3.4.6) - Water Quality (one or more of the following depending on project scope and discharge location):

- Basic, enhanced, and/or oil control.
- Enhanced treatment is required for projects discharging to sensitive habitat sites (see Figure 1 - 3 and Figure 1 - 4 for locations).

MR #7 (Vol. 1, Sec 3.4.7) - Flow Control (one of the following depending on final discharge location):

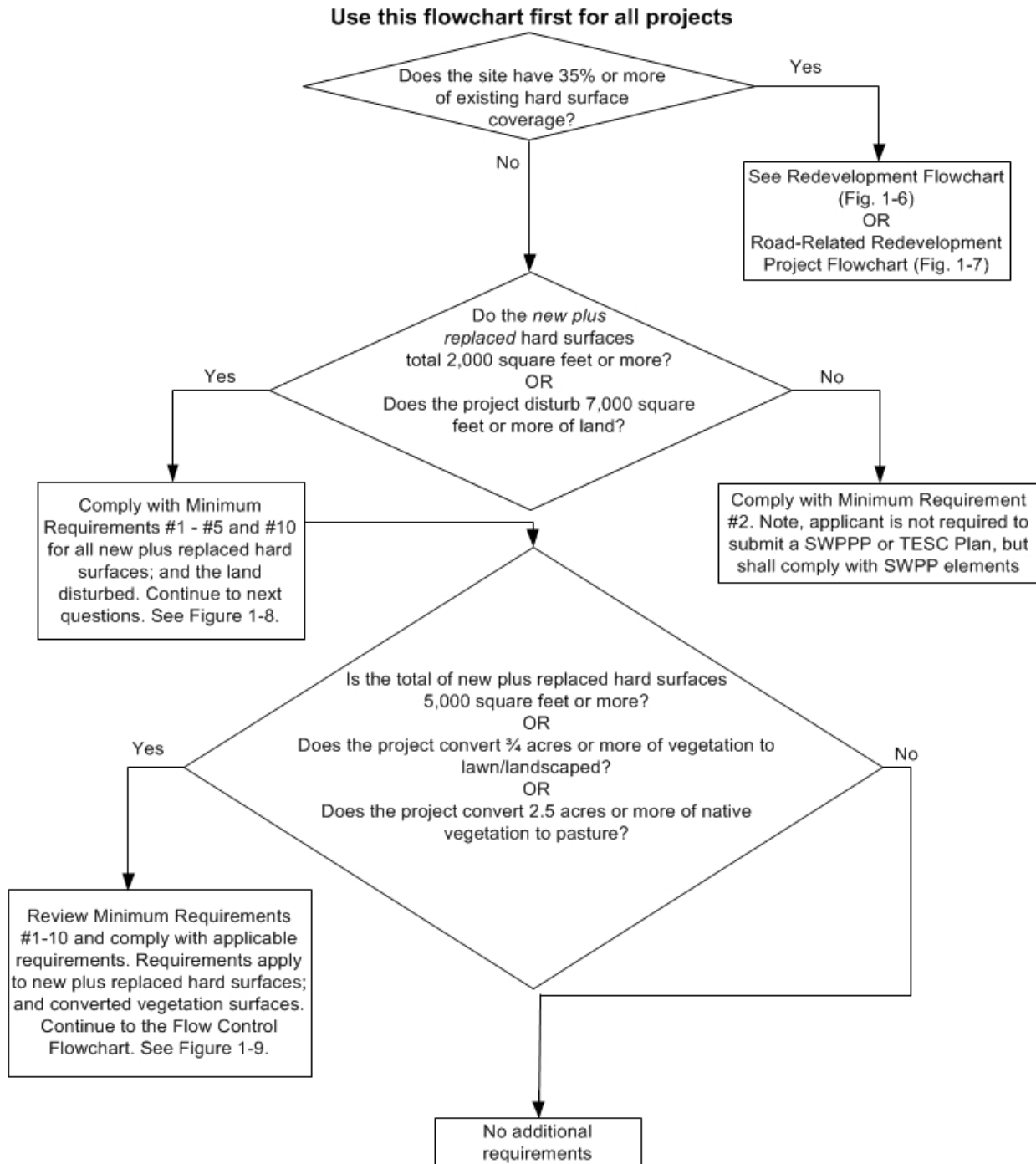
- Infrastructure Protection
- Standard Requirement – Forested Conditions (discharges to freshwater bodies).

### **3.3.7.9.2 Special Considerations**

Portions of the Western Slopes watershed discharge to adjacent municipalities. In these cases, the more stringent requirements between the City of Tacoma Stormwater Management Manual and the receiving municipality will be applied for determining stormwater mitigation requirements.

### **3.3.8 Flowcharts**

The flowcharts in Figure 1 - 5, Figure 1 - 6, Figure 1 - 7, Figure 1 - 8, and Figure 1 - 9 are intended as guidance for determining Minimum Requirements. The figures do not provide a complete analysis of each Minimum Requirement. The applicant must review Volume 1, Chapter 3 to determine the stormwater requirements for their project. The written text shall take precedence over the flowcharts.

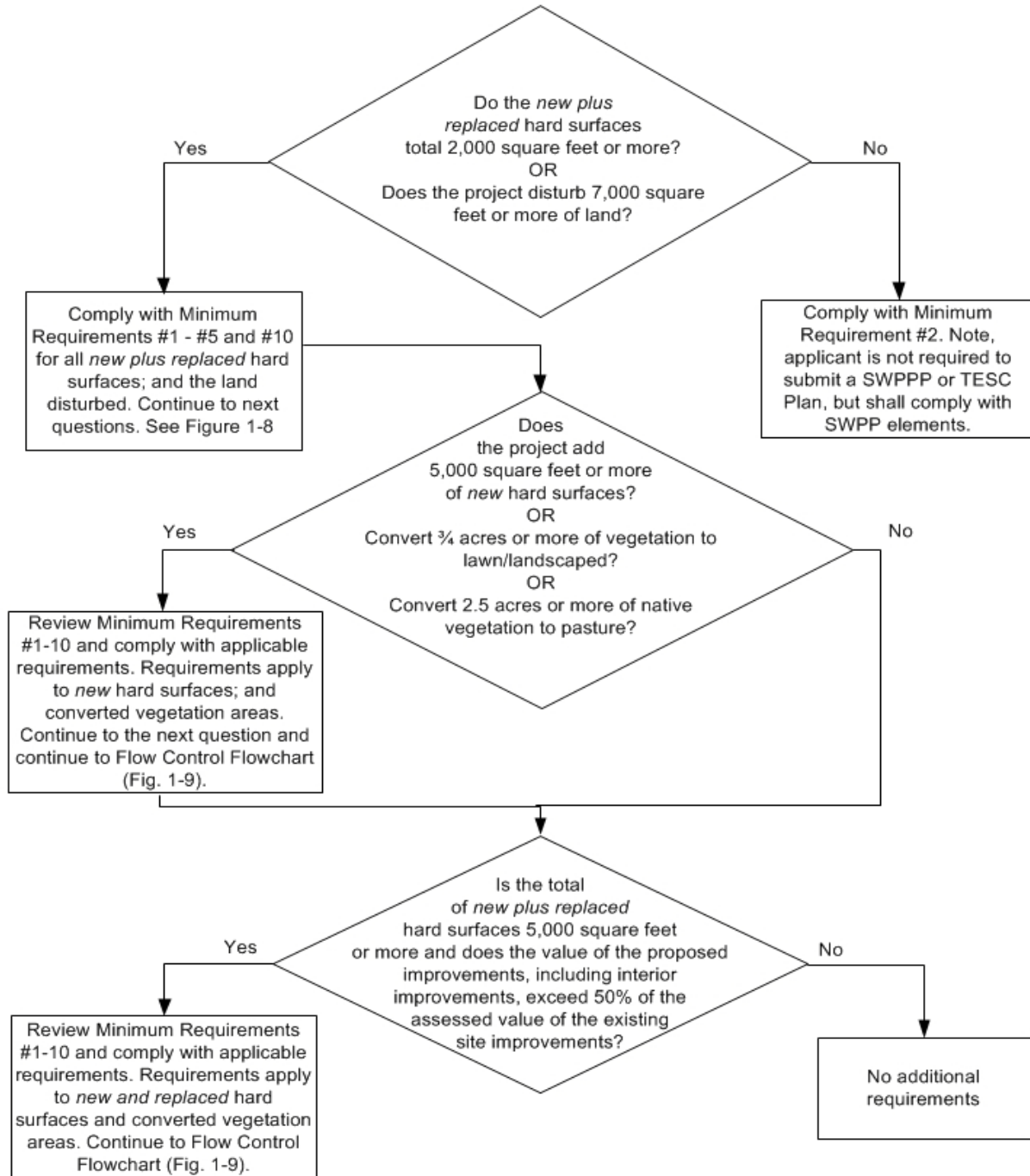


**NOTES:**

1. The combined total of *new and replaced* surfaces since January 1, 2003 shall apply when determining the thresholds.
2. Minimum Requirement #9 may apply to any project regardless of size.
3. Watershed specific requirements may or may not require compliance with certain minimum requirements regardless of site size.
4. It is the applicant's responsibility to determine the final discharge location for all projects.
5. For road-related projects, the redevelopment flowchart (Figure 1-6) is not used.
6. Disturb refers to land disturbing activities. See Glossary.

**Figure 1 - 5. New Development Flowchart**

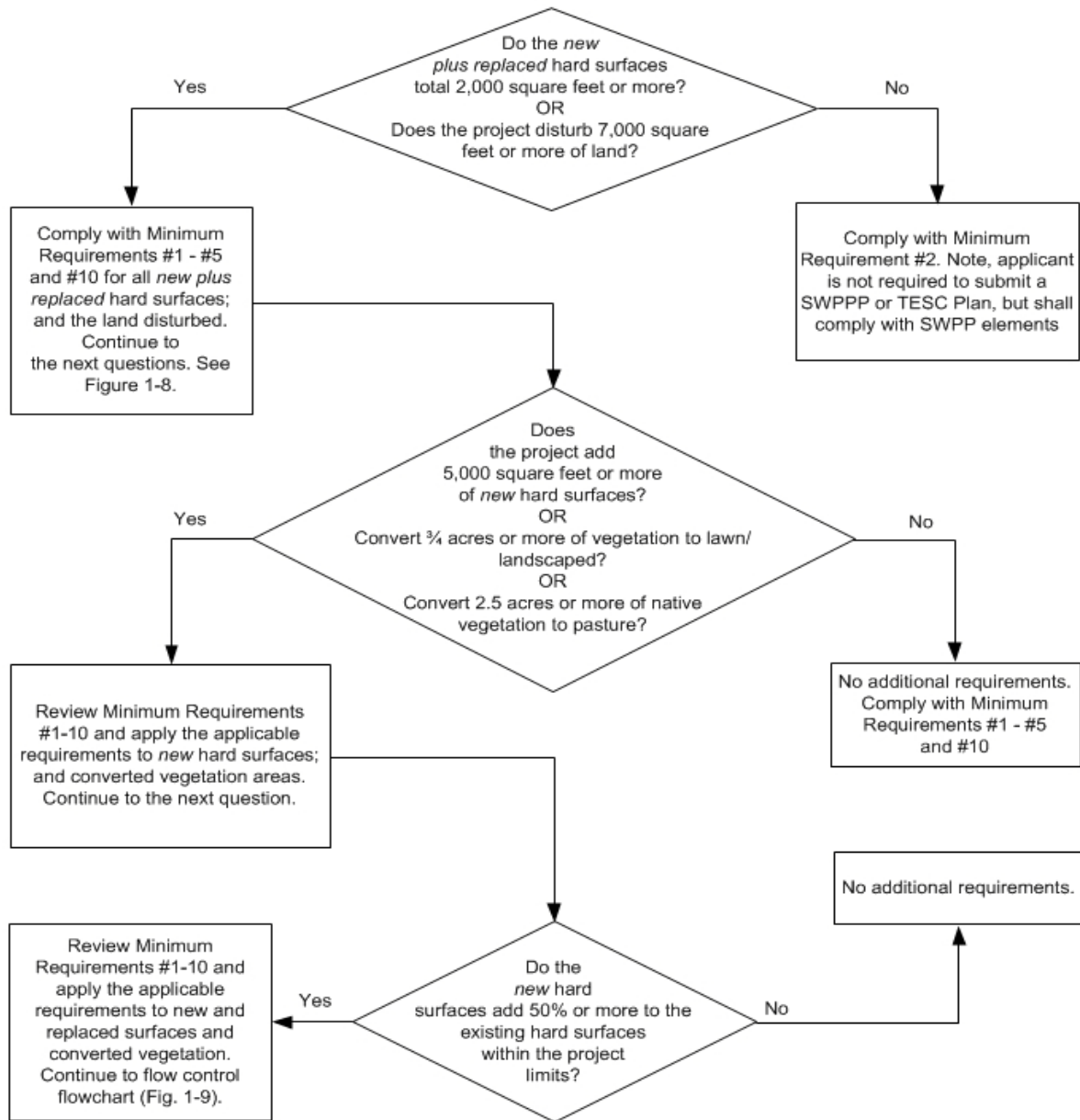




**NOTES:**

1. The combined total of *new and replaced* surfaces since January 1, 2003 shall apply when determining the thresholds.
2. Minimum Requirements #9 to any project regardless of size.
3. Watershed specific requirements may or may not require compliance with certain minimum requirements regardless of size.
4. It is the applicant's responsibility to determine the final discharge location for all projects.
5. Disturb refers to land disturbing activities. See Glossary

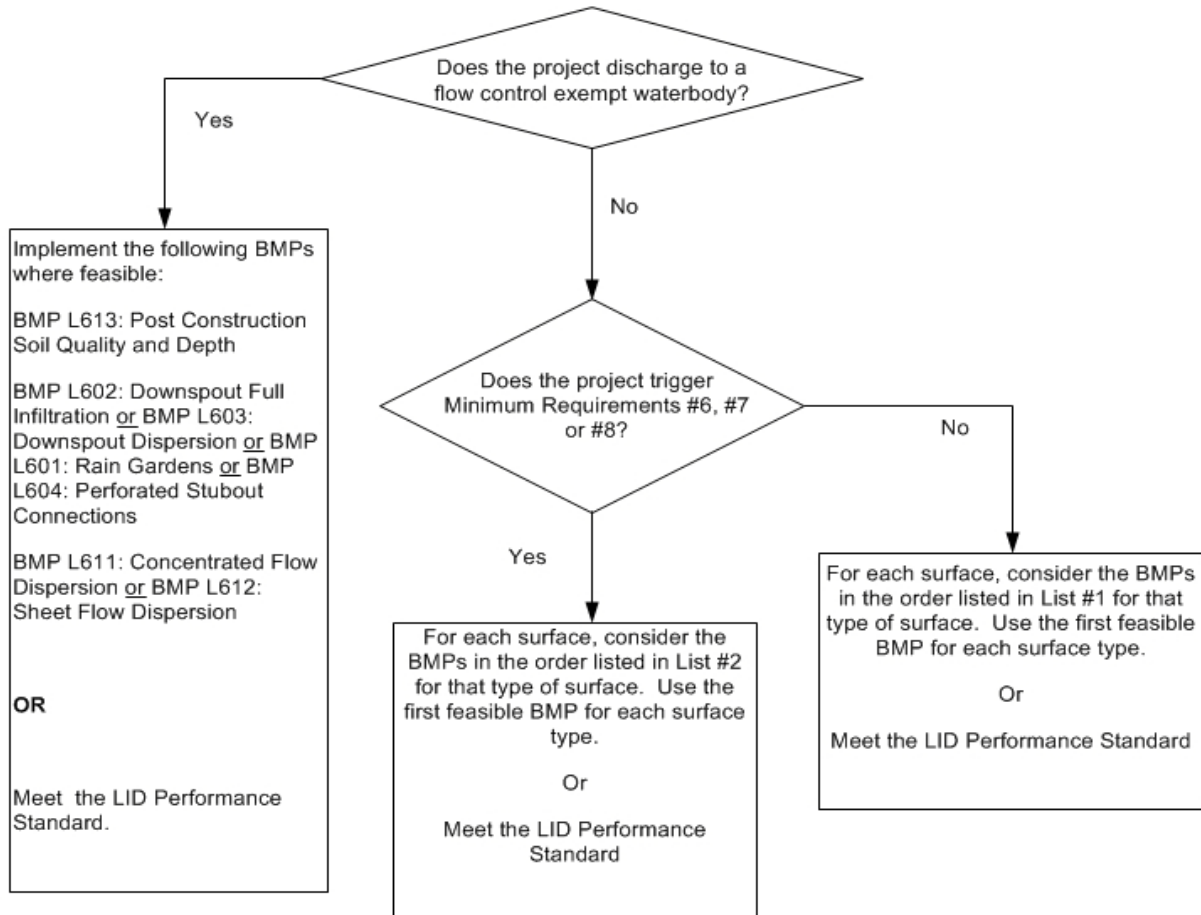
**Figure 1 - 6. Redevelopment Flowchart**



**NOTES:**

1. Road-related projects are those projects whose objective is the construction or maintenance of a road. Roads built as a requirement for permit issuance are not included in this category.
2. Watershed-specific requirements may or may not require compliance with certain minimum requirements regardless of size.
3. Minimum Requirement #9 may apply to any project regardless of site size.
4. It is the applicant's responsibility to determine the final discharge location for all projects.
5. Disturb refers to land disturbing activities. See Glossary.

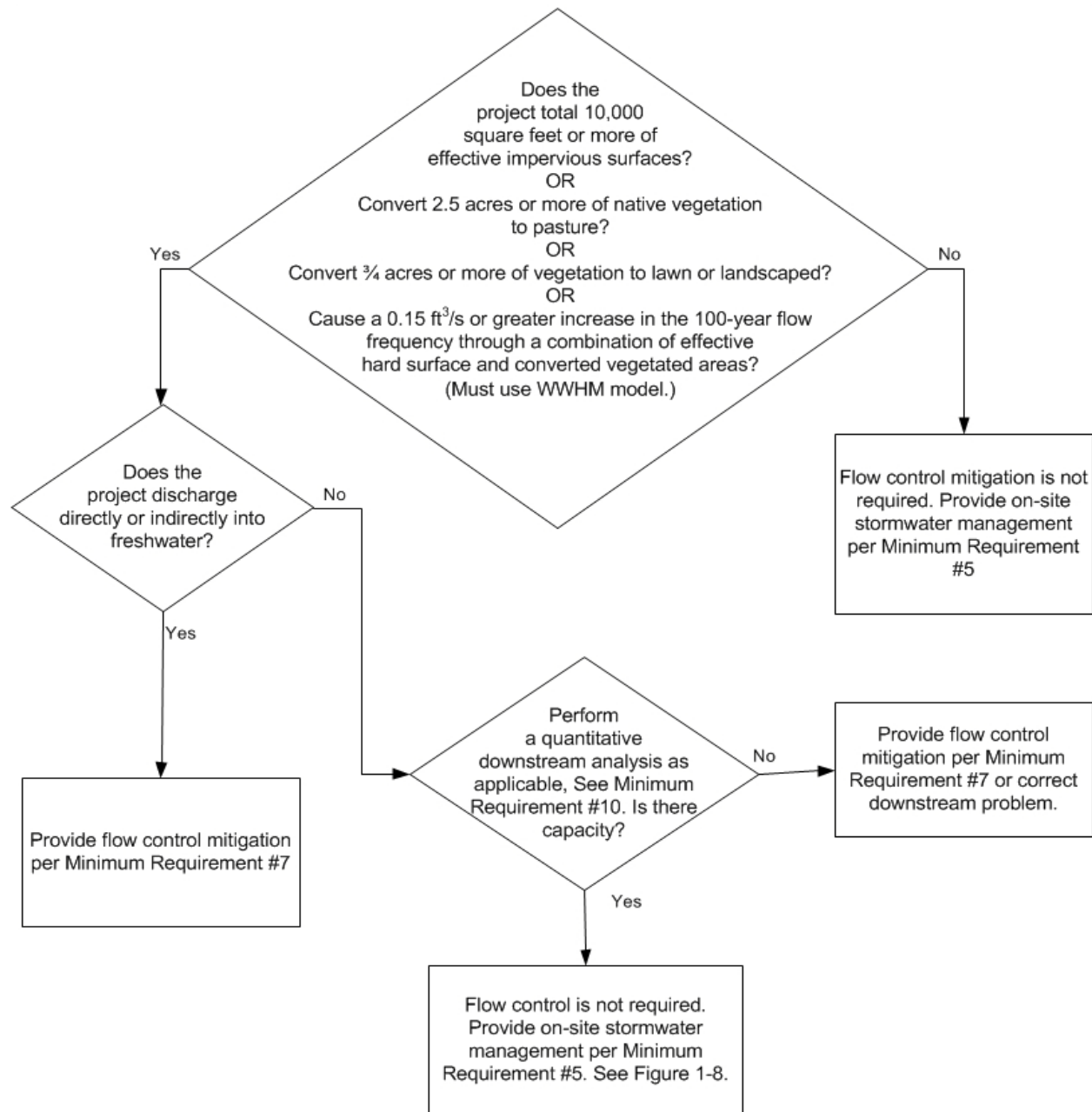
**Figure 1 - 7. Road-Related Redevelopment Flowchart**



**NOTES:**

1. Marine Waterbodies, the Puyallup River, and First Creek are considered flow control exempt waterbodies.
2. See Volume 1, Section 3.4.5.5 for List #1.
3. See Volume 1, Section 3.4.5.6 for List #2.

**Figure 1 - 8. Minimum Requirement #5 Flowchart**



**NOTES:**

- 1 Minimum Requirements #9 may apply to any project regardless of site size.
2. Watershed specific requirements may or may not require compliance with certain minimum requirements regardless of site size.
3. The Puyallup River is considered a flow-control exempt waterbody. See Section 3.4.7.5 for flow control requirements.
4. It is the applicant's responsibility to determine the final natural discharge location for all projects.
5. 0.15 ft<sup>3</sup>/s increase using 15-minute time steps.

**Figure 1 - 9. Flow Control Flowchart**

### **3.4 Description of Minimum Requirements**

This section describes the Minimum Requirements for stormwater management for new development and redevelopment projects. Consult Section 3.3 to determine which requirements apply to any given project.

Volumes 2 through 6 of this manual present Best Management Practices (BMPs) for use in meeting the Minimum Requirements.

#### **3.4.1 Minimum Requirement #1: Preparation of a Stormwater Site Plan**

All projects meeting the thresholds in Section 3.3 shall prepare a Stormwater Site Plan for Environmental Services review. Stormwater Site Plans shall use site-appropriate development principles to retain native vegetation and minimize impervious surfaces to the extent feasible. The following principles should be used where feasible: minimization of land disturbances by fitting development to the natural terrain; minimization of land disturbance by confining construction to the smallest area feasible and away from critical areas; preservation of natural vegetation; locating impervious surfaces over less permeable soils; clustering buildings; and minimizing impervious surfaces. Stormwater Site Plans shall be prepared in accordance with Chapter 4 of this Volume.

A Stormwater Site Plan consists of an assessment of both temporary and permanent stormwater and drainage impacts.

##### **3.4.1.1 Objective**

To outline the existing and post-developed conditions of the project site, describe the proposed stormwater facilities, and present the stormwater analysis.

#### **3.4.2 Minimum Requirement #2: Construction Stormwater Pollution Prevention**

All new development and redevelopment projects are responsible for preventing erosion and discharge of sediment and other pollutants into receiving waters.

Projects which meet or exceed the thresholds of Volume 1, Section 3.3.1 - New Development and Section 3.3.2 - Redevelopment and Grade and Fill Projects per Volume 1, Section 3.3.5 must prepare a Construction Stormwater Pollution Prevention Plan (SWPPP) . Each of the thirteen elements must be considered and included in the Construction SWPPP unless site conditions render the element unnecessary and the exemption from that element is clearly justified in the narrative of the SWPPP.

The SWPPP shall be implemented with initial land disturbance and continue until final project site stabilization.

The City has developed a Construction SWPPP Short Form which is available in Volume 2, Appendix C. The form may be used for projects that:

- Add or replace between 2,000 and 5,000 square feet of hard surface.
- Clear or disturb between 7,000 square feet and 1 acre of land.
- Grade/fill 50 - 499 cubic yards of material.

If project quantities exceed any of the above thresholds, a long form Construction SWPPP as described in Volume 2, Chapter 2 must be prepared.

Unless located in a Critical Area, projects below the new and redevelopment thresholds are not required to prepare a Construction SWPPP, but must consider all thirteen Elements of Construction Stormwater Pollution Prevention and develop controls for all elements that pertain to the project site.

SWPP Elements are:

- Element 1: Preserve Vegetation/Mark Clearing Limits*
- Element 2: Establish Construction Access*
- Element 3: Control Flow Rates*
- Element 4: Install Sediment Controls*
- Element 5: Stabilize Soils*
- Element 6: Protect Slopes*
- Element 7: Protect Drain Inlets*
- Element 8: Stabilize Channels and Outlets*
- Element 9: Control Pollutants*
- Element 10: Control De-Watering*
- Element 11: Maintain BMPs*
- Element 12: Manage the Project*
- Element 13: Protect BMPs*

These Elements are described in detail in Volume 2.

#### **3.4.2.1 Objective**

To control erosion and prevent sediment and other pollutants from leaving the site during the construction phase of a project. To have fully functional stormwater facilities and BMPs for the developed site upon completion of construction.

#### **3.4.3 Minimum Requirement #3: Source Control of Pollution**

All known, available and reasonable source control BMPs shall be applied to all projects. Source control BMPs shall be selected, designed, and maintained according to this manual. Structural source control BMPs shall be identified in the stormwater site plan and shall be shown on construction plans submitted for City review.

Source Control BMPs include Operational BMPs and Structural Source Control BMPs. See Volume 4 for design details of these BMPs. For construction sites, see Volume 2, Chapter 3.

#### **3.4.3.1 Objective**

The intent of source control BMPs is to prevent stormwater from coming in contact with pollutants. They are a cost-effective means of reducing pollutants in stormwater, and, therefore, should be a first consideration in all projects.

#### **3.4.4 Minimum Requirement #4: Preservation of Natural Drainage Systems and Outfalls**

For all projects, the natural drainage patterns shall be maintained, and discharges from the project site shall occur at the natural location, to the maximum extent practicable. The manner by which runoff is discharged from the project site must not cause a significant adverse impact to downstream receiving waters and downgradient properties. All outfalls require energy dissipation.

As part of the Stormwater Site Plan Report (Volume 1, Chapter 4), the applicant shall identify the final discharge location, the most sensitive receiving water, the location of natural drainage, topography, historic drainage information and any potential impacts.

#### **3.4.4.1 Objective**

To preserve and utilize natural drainage systems to the fullest extent practicable because of the multiple stormwater benefits these systems provide; and to prevent erosion at and downstream of the discharge location.

#### **3.4.4.2 Supplemental Guidelines**

Where stormwater must be discharged offsite, an applicant may discharge surface flow onto neighboring properties if the surface flow has not been concentrated or increased as a result of the project development. An applicant may be allowed to discharge concentrated or increased flows that comply with the guidelines in this section only if the applicant has obtained the legal rights to discharge onto neighboring properties. Setback requirements for stormwater BMPs must be maintained as required and applicable for the given stormwater facility. Setback requirements are provided within the text of the individual BMP.

The following are guidelines to use when discharging increased or concentrated flows onto downgradient properties. Environmental Services shall determine which of the following discharge scenarios will be allowed.

- a. Conveyance to the City system at the direction of or with written approval from Environmental Services. If necessary, the City may require the City storm system to be extended to serve the project site.
- b. If the 100-year return period flowrate, as determined by WWHM, is less than or equal to 0.2 cfs under existing conditions and will remain less than or equal to 0.2 cfs under developed conditions, then the concentrated runoff may be discharged onto a rock pad or to any other system that serves to disperse flows and the rock pad or other system meets all design requirements of this manual.
- c. If the 100-year return period flowrate, as determined by WHMM, is less than or equal to 0.5 cfs under existing conditions and will remain less than or equal to 0.5 cfs under developed conditions, then the concentrated runoff may be discharged through a dispersal trench or other dispersal system, provided the applicant can demonstrate that there is no adverse impact to downhill properties or drainage systems and the dispersal system meets all design requirements of this manual.
- d. If the 100-year return period flowrate, as determined by WHMM, is greater than 0.5 cfs for either existing or developed conditions, or if a significant adverse impact to downgradient properties or drainage systems is likely, then a conveyance system must be provided to convey the concentrated runoff across the downstream properties to an acceptable discharge point.

#### **3.4.5 Minimum Requirement #5: Onsite Stormwater Management**

Projects shall employ, where feasible and appropriate, Onsite Stormwater Management BMPs to infiltrate, disperse, and retain stormwater runoff onsite to the maximum extent feasible without causing flooding, or erosion impacts.

### **3.4.5.1 Project Thresholds - Minimum Requirements #1-5**

Except as noted in Volume 1, Section 3.4.5.3, projects triggering only Minimum Requirements #1 through #5 and #10 shall either:

- a. Use onsite stormwater management BMPs from List #1, per Volume 1, Section 3.4.5.5, for all surfaces within each type of surface in List #1; OR
- b. Demonstrate compliance with the LID Performance Standard per Volume 1, Section 3.4.5.4. Projects selecting this option cannot use Rain Gardens to achieve the LID Performance Standard, although Bioretention BMPs as described in Volume 6 may be used. Projects selecting to demonstrate compliance with the LID Performance Standard must implement BMP L613 if feasible.

### **3.4.5.2 Project Thresholds – Minimum Requirements #1 - #10**

Except as noted in Volume 1, Section 3.4.5.3, projects triggering Minimum Requirements #1 through #10 shall either:

- a. Use onsite stormwater management BMPs from List #2 per Volume 1, Section 3.4.5.6, for all surfaces within each type of surface in List #2; OR
- b. Demonstrate compliance with the LID Performance Standard per Volume 1, Section 3.4.5.4. Projects selecting this option cannot use Rain Gardens to achieve the LID Performance Standard, although Bioretention BMPs as described in Volume 6 may be used. Projects selecting to demonstrate compliance with the LID Performance Standard must implement BMP L613 if feasible.

### **3.4.5.3 Project Thresholds – Marine Waterbodies and Flow Control Exempt Waterbodies**

Projects that discharge to marine waters and waterbodies that are considered flow control exempt per Volume 1, Section 3.4.7.4, do not have to achieve the LID Performance Standard per Volume 1, Section 3.4.5.4, or use List #1 per Volume 1, Section 3.4.5.5, or List #2 per Volume 1, Section 3.4.5.6 but shall employ the following BMPs as feasible.

#### **Roofs:**

- a. Roof Downspout Controls BMPs, as described in Volume 3, Chapter 2:
  - BMP L602: Downspout Full Infiltration (Vol 3, Sec 2.3.3); OR
  - BMP L603: Downspout Dispersion (Vol 3, Sec 2.4); OR
  - BMP L604: Perforated Stub-out Connections (Vol 3, Sec 2.5); OR
  - BMP L605: Collect and convey to the City system (Vol 3, Sec 2.6), only if infiltration, dispersion, and perforated stubout connections are not feasible.

#### **Other Hard Surfaces:**

- b. Dispersion BMPs as described in Volume 3, Chapter 3:
  - BMP L611 – Concentrated Flow Dispersion (Vol 3, Sec 3.1); OR
  - BMP L612 – Sheet Flow Dispersion (Vol 3, Sec 3.2); OR



- BMP L605: Collect and convey to the City system (Vol 3, Sec 2.6), only if concentrated flow dispersion and sheet flow dispersion are not feasible.

#### **Lawn and Landscaped Areas:**

- c. BMP L613 Post-Construction Soil Quality and Depth

Applicants may choose to achieve the LID Performance Standard or utilize List #1 or List #2. If utilizing List #1 or List #2, applicants do not have to consider bioretention, rain gardens, permeable pavement, and full dispersion although any of these Best Management Practices would be allowed.

#### **3.4.5.4 Low Impact Development Performance Standard**

Stormwater discharges shall match developed discharge durations to predeveloped durations for the range of predeveloped discharge rates from 8% of the 2-year return period flowrate to 50% of the 2-year return period flowrate. Refer to Minimum Requirement #7 for the predeveloped condition to be modeled. Projects that must also meet Minimum Requirement #7 must match flow durations between 8% of the 2-year through the full 50-year flow.

#### **3.4.5.5 List #1 Onsite Management BMPs for Projects Triggering only Minimum Requirement #1- #5**

For each surface category (Lawn and Landscaped Areas, Roofs, and Other Hard Surfaces), consider the BMPs in the order listed. Use the first BMP that is considered feasible. If a BMP is considered feasible, no other BMP is required to be used for that surface category. Feasibility shall be determined by evaluation against:

1. Design criteria, limitations, and infeasibility criteria identified for each BMP in this manual; and
2. Competing Needs Criteria listed in Volume 1, Section 3.4.5.7.

#### **Lawn and Landscaped Areas:**

- Post Construction Soil Quality and Depth in accordance with BMP L613 (Vol 3, Sec 4.1)

#### **Roofs:**

1. Either: (The applicant shall evaluate both a and b for feasibility)
  - a. Full Dispersion in accordance with BMP L614 (Vol 3, Sec 3.3), OR
  - b. Downspout Full Infiltration Systems in accordance with BMP L602 (Vol 3, Sec 2.3.3)
2. Either: (The applicant shall choose either a or b to evaluate for feasibility)
  - a. Rain Gardens in accordance with BMP L601 (Vol 6, Sec 2.2.2.1), OR
  - b. Bioretention in accordance with BMP L630 (Vol 6, Sec 2.2.2.2)

The rain garden or bioretention surface area must have a minimum horizontal projected surface area below the overflow which is at least 5% of the area draining to it.

3. Downspout Dispersion Systems in accordance with BMP L603 (Vol 3, Sect 2.4).
4. Perforated Stub-Out Connections in accordance with BMP L604 (Vol 3, Sec 2.5.)

5. Collect and Convey in accordance with BMP L605 (Vol 3, Sec 2.6)

#### **Other Hard Surfaces**

1. Full Dispersion in accordance with BMP L614 (Vol 3, Sec 3.3).
2. Either: (The applicant shall choose either a, b or c to evaluate for feasibility)
  - a. Permeable pavement in accordance with BMP L633 (Vol 6, Sec 2.2.2.5); OR  
This is not a requirement to pave these surfaces. Where pavement is proposed, it must be permeable to the extent feasible unless full dispersion is employed
  - b. Rain Garden in accordance with BMP L601 (Vol 6, Sec 2.2.2.1); OR
  - c. Bioretention in accordance with BMP L630 (Vol 6, Sec 2.2.2.2).  
The rain garden or bioretention facility must have a minimum horizontal projected surface area below the overflow which is at least 5% of the area draining to it.
3. Either: (The applicant shall evaluate both a and b for feasibility)
  - a. Sheet Flow Dispersion in accordance with BMP L612 (Vol 3, Sec 3.2), OR
  - b. Concentrated Flow Dispersion in accordance with BMP L611 (Vol 3, Sec 3.1).
4. Collect and convey in accordance with BMP L605 (Vol 3, Sec 2.6)

#### **3.4.5.6 List #2 Onsite Management BMPs for Projects Triggering Minimum Requirements #1- #10.**

For each surface category (Lawn and Landscaped Areas, Roofs, and Other Hard Surfaces), consider the BMPs in the order listed. Use the first BMP that is considered feasible. If a BMP is considered feasible, no other BMP is required to be used for that surface category. Feasibility shall be determined by evaluation against:

1. Design criteria, limitations, and infeasibility criteria identified for each BMP in this manual; and
2. Competing Needs Criteria listed in Volume 1, Section 3.4.5.7.

#### **Lawn and Landscaped Areas:**

- Post Construction Soil Quality and Depth in accordance with BMP L613 (Volume 3, Section 4.1)

#### **Roofs:**

1. Either (The applicant shall evaluate both a and b for feasibility)
  - a. Full Dispersion in accordance with BMP L614 (Vol 3, Section 3.3) or
  - b. Downspout Infiltration Systems in accordance with BMP L602 (Vol 3, Section 2.3.3).
2. Bioretention in accordance with BMP L630 (Vol 6, Section 2.2.2.2). The bioretention facility must have a minimum horizontal projected surface area below the overflow which is at least 5% of the area draining to it.
3. Downspout Dispersion Systems in accordance with BMP L603 (Vol 3, Sec 2.4).
4. Perforated Stub-Out Connections in accordance with BMP L604 (Vol 3, Sec 2.5.)

5. Collect and Convey in accordance with BMP L605 (Vol 3, Sec 2.6)

#### **Other Hard Surfaces**

1. Full Dispersion in accordance with BMP L614 (Vol 3, Sec 3.3).
2. Permeable pavement in accordance with BMP L633 (Vol 6, Sec 2.2.2.5). This is not a requirement to pave these surfaces. Where pavement is proposed, it must be permeable to the extent feasible unless full dispersion is employed.
3. Bioretention in accordance with BMP L630 (Vol 6, Sec 2.2.2.2). The bioretention facility must have a minimum horizontal projected surface area below the overflow which is at least 5% of the area draining to it.
4. Either: (The applicant shall evaluate both a and b for feasibility)
  - a. Sheet Flow Dispersion in accordance with BMP L612 (Vol 3, Sec 3.2), OR
  - b. Concentrated Flow Dispersion in accordance with BMP L611 (Vol 3, Sec 3.1)
5. Collect and Convey in accordance with BMP L605 (Vol 3, Sec 2.6)

#### **3.4.5.7 Competing Needs**

The Onsite Stormwater Management BMP requirements can be superseded or reduced where they are in conflict with:

- Requirements of the following federal or state laws, rules, and standards: Historic Preservation Laws and Archaeology Laws as listed at <http://www.dahp.wa.gov/learn-and-research/preservation-laws>, Federal Superfund or Washington State Model Toxics Control Act, Federal Aviation Administration requirements for airports, Americans with Disabilities Act.
- When found to be in conflict with special zoning district design criteria adopted and being implemented pursuant to a community planning process.
- Public health and safety standards.
- Transportation regulations to maintain the option for future expansion or multi-modal use of public rights-of-way.
- A local Critical Area Ordinance that provides protection of tree species or other critical areas.

#### **3.4.5.8 Objective**

To use stormwater management practices on individual properties to reduce the amount of disruption to the natural hydrologic characteristics of the site.

### **3.4.6 Minimum Requirement #6: Water Quality Treatment**

#### **3.4.6.1 Thresholds**

When assessing a project against the following thresholds, only consider those hard and pervious surfaces that are subject to this minimum requirement as determined in Volume 1, Section 3.3.

The following require construction of stormwater treatment facilities:

- Projects in which the total of pollution-generating hard surface (PGHS) is 5,000 square feet or more in a threshold discharge area of the project, or

- Projects in which the total of pollution-generating pervious surfaces (PGPS) - not including permeable pavements - is three-quarters (3/4) of an acre or more in a threshold discharge area, and from which there will be a surface discharge in a natural or man-made conveyance system from the site.

Minimum Requirement #8 - Wetlands Protection per Volume 1, Section 3.4.8 may apply to direct or indirect discharges to wetlands or streams. See Minimum Requirement #8 for additional information.

### **3.4.6.2 Treatment Facility Selection, Design, and Maintenance**

#### **Stormwater treatment facilities shall be:**

- Selected in accordance with the process identified in Volume 5, Chapter 1;
- Designed in accordance with the design criteria in Volume 5; and
- Sized for the entire area that drains to them, even if some of those areas are not pollution-generating or were not included in the project site threshold decisions. Runoff from non-pollutant generating surfaces that commingles with runoff from pollutant-generating surfaces shall be treated. Non-pollution generating surface runoff may be bypassed around the treatment facility.
- Maintained in accordance with the maintenance standards in Volume 1, Appendix C that shall be incorporated in the design as part of a facility operation and maintenance manual.

### **3.4.6.3 Additional Requirements**

- The thresholds above apply to both a project's onsite and offsite improvements. Once the project is required to meet this Minimum Requirement, all affected pollution generating surfaces are required to provide treatment. No net or average is permitted between non-pollution generating surfaces and pollution generating.
- Direct discharge of untreated stormwater from pollution-generating hard surfaces to groundwater is prohibited, except for the discharge achieved by infiltration or dispersion of runoff through the use of Onsite Stormwater Management BMPs, designed in accordance with this manual; or by infiltration through soils meeting the soil suitability criteria of Volume 5, Chapter 7.
- The City of Tacoma and Tacoma-Pierce County Health Department developed a guidance document that provides the circumstances and requirements for approval of infiltration facilities for managing pollution-generating stormwater runoff in the South Tacoma Groundwater Protection District. This document, "Implementation of Stormwater Infiltration for Pollution-Generating Surfaces in the South Tacoma Groundwater Protection District" is available in Volume 5, Appendix D and at [www.cityoftacoma.org/stormwatermanual](http://www.cityoftacoma.org/stormwatermanual) under stormwater policy updates.

### **3.4.6.4 In-Lieu of Payment Option**

In lieu of constructing stormwater treatment facilities, applicants may pay a fee to the City of Tacoma. The payment will offset construction of City owned and maintained regional stormwater facilities. The "Regional Stormwater Facilities Program" document available at [www.cityoftacoma.org/stormwater](http://www.cityoftacoma.org/stormwater) contains the program requirements, fees, and project feasibility criteria.

### **3.4.6.5 Objective**

The purpose of runoff treatment is to reduce pollutant loads and concentrations in stormwater runoff using physical, biological, and chemical removal mechanisms so that beneficial uses of

receiving waters are maintained and, where applicable, restored. When site conditions are appropriate, infiltration can potentially be the most effective BMP for runoff treatment.

### **3.4.7 Minimum Requirement #7: Flow Control**

#### **3.4.7.1 Flow Control Applicability**

Projects meeting or exceeding the flow control thresholds must provide flow control to reduce the impacts of stormwater runoff from hard surfaces and land cover conversions. The applicability and type of flow control that may be required is based upon discharge location and project impacts. Volume 1, Section 3.3.7 contains flow control requirements that are typically applicable to each watershed in the City of Tacoma when the thresholds for flow control are met or exceeded.

If the discharge is to a stream that leads to a wetland, or to a wetland that has an outfall to a stream, both Minimum Requirement #7 and Minimum Requirement #8 apply.

When assessing a project against flow control thresholds, only consider those hard and pervious surfaces that are subject to this Minimum Requirement as determined in Volume 1, Section 3.3.

Environmental Services may make the determination that the flow control standards be applied to any project based upon known downstream erosion issues or potential erosion issues.

#### **3.4.7.2 Freshwater Protection Requirement**

##### **3.4.7.2.1 Thresholds – Freshwater Protection Requirement**

Projects that meet or exceed any of the following thresholds and discharge stormwater directly or indirectly through a conveyance system into a freshwater body require compliance with Minimum Requirement #7, and shall provide mitigation per Section 3.4.7.2.2.

- Projects in which the total of effective impervious surfaces is 10,000 square feet or more in a threshold discharge area, or
- Projects that convert  $\frac{3}{4}$  acres or more of vegetation to lawn/landscape, or convert 2.5 acres or more of native vegetation to pasture in a threshold discharge area, and from which there is a surface discharge in natural or man-made conveyance systems from the site, or
- Projects that, through a combination of hard surfaces and converted vegetation areas, cause a 0.15 cfs or greater increase in the 100-year return period flowrate from a threshold discharge area as estimated using the Western Washington Hydrology Model (assuming a 15-minute time step). Comparison shall be between existing and proposed site conditions.

##### **3.4.7.2.2 Mitigation – Freshwater Protection Requirement**

###### **3.4.7.2.2.1 Mitigation –Forested Condition**

Forested Condition mitigation shall apply to those projects meeting or exceeding the thresholds of Section 3.4.7.2.1 and with discharges to freshwater bodies located in the Flett Creek, Leach Creek, Joe's Creek, Northeast Tacoma, and Western Slopes Watersheds.

Using WWHM for design, stormwater discharges shall match developed discharge durations to predeveloped discharge durations for the range of predeveloped discharge rates from 50% of the 2-year return period flowrate up to the full 50-year return period flowrate. The predeveloped condition to be matched shall be a forested land cover.

In lieu of constructing stormwater flow control facilities, applicants may pay a fee to the City of Tacoma. The payment will offset construction of City owned and maintained regional stormwater facilities. The “Regional Stormwater Facilities Program” document available at [www.cityoftacoma.org/stormwater](http://www.cityoftacoma.org/stormwater) contains the program requirements, fees, and project feasibility criteria.

### **3.4.7.2.2 Mitigation - Existing Condition**

The Existing Condition mitigation shall apply to those projects meeting or exceeding the threshold of Section 3.3.7.4.1 and with discharges to freshwater bodies located in the North Tacoma, Thea Foss Waterway, Tideflats, and Lower Puyallup Watersheds (except as noted in Section 3.4.7.4).

Using WWHM for design, stormwater discharges shall match developed discharge durations to existing discharge durations for the range of existing discharge rates from 50% of the 2-year return period flowrate up to the full 50-year return period flowrate.

### **3.4.7.3 Infrastructure Protection Requirement**

#### **3.4.7.3.1 Thresholds– Infrastructure Protection**

Projects that discharge stormwater directly or indirectly to any of the following require compliance with Minimum Requirement #7 – Infrastructure Protection:

- To a conveyance system without capacity to convey the fully developed design event as determined through a full backwater quantitative downstream analysis and/or Inlet and Gutter Capacity Analyses per Volume 1, Section 3.4.10; or
- To a capacity problem downstream of the project as determined by Environmental Services using City-Wide Capacity Modeling per Volume 1, Section 3.4.10.2; or
- To a manmade conveyance system (ditch, swale, etc.) which has not been adequately stabilized to prevent erosion as determined by the downstream qualitative analysis per Volume 1, Section 3.4.10.2 or as determined by Environmental Services.

Infrastructure Protection is satisfied if any of the following are met and no further mitigation is required per Minimum Requirement #7:

- Projects that do not trigger the thresholds above, or
- Projects that trigger mitigation per the Freshwater Protection Requirement (Vol. 1. Sec. 3.3.7.2.2), or
- Projects that discharge to a City-owned and identified trunk main, or
- Projects that increase the surface area contributing to the downstream system by less than 5,000 square feet, or
- Projects that increase the surface area contributing to the downstream system by less than 10,000 square feet and discharge to a pipe system that has a pipe that is 12” in diameter or greater within ¼ mile from the discharge location.

#### **3.4.7.3.2 Mitigation – Infrastructure Protection**

Projects required to comply with Minimum Requirement #7 – Infrastructure Protection may resolve the downstream capacity problem (e.g., upsize the downstream system or provide additional inlets) or provide onsite infiltration or detention. Where infiltration or detention is provided, stormwater discharges for the developed condition shall not exceed the discharges under existing conditions. The applicant is not required to match flow durations but can match flowrates for all flow frequencies analyzed by WWHM. If onsite detention or infiltration is

proposed instead of upsizing the downstream system, the owner must provide a signed letter stating that they understand the proposal and accept the operation and maintenance of the onsite system.

#### **3.4.7.4 Flow Control Exempt Waterbodies**

If all of the following requirements are met, Flow Control – Freshwater Protection Requirement is not required for projects that discharge directly or indirectly to the Puyallup River or First Creek. If stormwater discharges to First Creek the analysis does not need to extend to the Puyallup River. First Creek shall be considered the entire First Creek system including the gulch, First Creek waterway, and City-owned conveyance piping within the First Creek system. If any of the following requirements are not met, mitigation for flow control per the Freshwater Protection Requirement - Existing Condition in Section 3.4.7.2.2.2 is required.

- Direct discharge to the Puyallup River or First Creek does not result in the diversion of drainage from any perennial stream classified as Types 1,2,3, or 4 in the State of Washington Interim Water Typing System or Types "S", "F", or "Np" in the Permanent Water Typing System, or from any category I, II, or III wetland; and
- Flow splitting devices or drainage BMPs are applied to route natural runoff volumes from the project site to any downstream Type 5 stream or category IV wetland:
  - Design of flow splitting devices or drainage BMPs will be based on continuous hydrologic modeling analysis. The design will assure that flows delivered to Type 5 stream reaches will approximate, but in no case exceed, durations ranging from 50% of the 2-year to the 50-year return period flowrate.
  - Flow splitting devices or drainage BMPs that deliver flow to category IV wetlands will also be designed using continuous hydrologic modeling to preserve existing wetland hydrologic conditions unless specifically waived or exempted by the City of Tacoma; and
- The project site must discharge through a conveyance system that is comprised entirely of manmade conveyance elements (e.g., pipes, ditches, outfall protection, dispersion BMPs above or at high water line, etc.) and extends to the ordinary high water line of the Puyallup River or First Creek; and
- The conveyance system between the project site and the Puyallup River or First Creek shall have sufficient hydraulic capacity to convey discharges from future build-out conditions of the site (see Volume 3, Chapter 9), and the existing conditions from non-project areas from which runoff is or will be collected.

This section requires a downstream analysis of the entire conveyance system between the project site and the flow control exempt waterbody.

See Volume 1, Section 3.4.10.2 to determine the type of downstream analysis required.

- Any erodible elements of the manmade conveyance system must be adequately stabilized to prevent erosion under the conditions noted above.

#### **3.4.7.5 Modeling Requirements**

To meet the Freshwater Protection Requirement in Section 3.4.7.2 or if proposing infiltration or detention to meet the Infrastructure Protection Requirement in 3.4.7.3, the applicant shall use the Western Washington Hydrology Model to size the flow control facilities. The applicant must use a single-event model to model conveyance systems.

There are several acceptable computer models available; however, the designer shall use the most recent version of any proposed software that has been updated with any substantive changes. The designer shall provide a copy of the completed hydrology analysis worksheet (Appendix B) and a copy of the electronic project file.

#### **3.4.7.6 Flow Control Design, Offsite Inflow, and Bypass**

Flow control facilities shall be sized for the entire flow that is directed to them, however, bypass may be allowed as described below.

Offsite inflow may be bypassed around the flow control facility provided the existing 100-year return period flowrate from any upstream offsite areas is no greater than 50% of the 100-year developed return period flowrate (undetained) from the project site. The bypass of offsite inflow shall be designed to achieve the following:

- Any existing contribution of flows to onsite wetlands must be maintained.
- Offsite inflows that are naturally attenuated by the project site under predeveloped or existing conditions must remain attenuated, either by natural means or by providing additional onsite detention so that flows do not increase.
- Bypassed stormwater shall not cause damage to downstream systems or properties and shall meet the requirements of Volume 1, Section 3.4.4.2.

Stormwater runoff created by surfaces that require detention may bypass the flow control facility provided all the following conditions are met:

- Runoff from both the bypass area and the flow control facility shall converge within ¼ mile downstream of the project site discharge point.
- The flow control facility shall be designed to compensate for the uncontrolled bypass area such that the net downstream discharge is the same with or without bypass.
- The 100-year return period flowrate from the bypass area will not exceed 0.4 cfs.
- Runoff from the bypass area will not create a significant adverse impact to downstream systems or drainage and shall meet the requirements of Volume 1, Section 3.4.4.2.

Water quality is applied to the bypass areas as applicable.

#### **3.4.7.7 Objective**

The purpose of flow control – freshwater body protection requirement is to prevent increases in natural stream channel erosion rates. The standard intends to maintain the total amount of time that a receiving stream exceeds an erosion causing threshold based upon historic rainfall and natural land cover conditions. That threshold is assumed to be 50% of the 2-year return period flowrate. Maintaining the naturally occurring erosion rates within streams is vital, though by itself insufficient, to protect fish habitat and production. The purpose of flow control for infrastructure protection is to prevent downstream flooding that may be caused by increased runoff to existing City infrastructure.

#### **3.4.8 Minimum Requirement #8: Wetlands Protection**

Wetlands are regulated by the City of Tacoma through this requirement and the Critical Areas Preservation Ordinance, Tacoma Municipal Code 13.11. For more information about wetlands, wetland permits and development close to wetlands, please contact the Land Use Services Desk at (253) 591-5577.



### **3.4.8.1 Applicability**

When assessing a project against the following thresholds, only consider those hard and pervious surfaces that are subject to this minimum requirement as determined in Volume 1, Section 3.3.

Stormwater discharges to wetlands may require a wetland permit as detailed under the City's Critical Areas Preservation Ordinance (TMC 13.11).

The requirements below are in addition to requirements given in TMC 13.11 and apply only to projects whose stormwater discharges into a wetland, either directly or indirectly through a conveyance system.

Streams may also be regulated under this requirement as part of the wetland permit.

### **3.4.8.2 Thresholds**

When either of the thresholds identified in Minimum Requirement #6 – Runoff Treatment, or Minimum Requirement #7 – Flow Control are met or exceeded, this requirement shall also be applied. Minimum Requirement #8 applies regardless of final discharge location.

### **3.4.8.3 Standard Requirement**

Projects shall comply with Guide Sheets #1 through #3 in Appendix D. The hydrologic analysis shall use the existing land cover unless otherwise directed. Model calibration and pre- and post-development monitoring of wetlands, groundwater levels and water quality may be required.

### **3.4.8.4 Additional Requirements**

Stormwater treatment and flow control facilities shall not be constructed within a natural vegetated buffer, except for:

- Necessary conveyance systems as approved by the City; or
- As allowed in wetlands approved for hydrologic modification and/or treatment in accordance with Guidesheet 2 in Appendix D of this Volume.

If selective runoff bypass is proposed to maintain the hydroperiod, the hydraulic analysis shall consider the impacts of the bypassed flow. Bypassed flow shall comply with Minimum Requirement #6 and #7 as applicable.

### **3.4.8.5 Objective**

Wetlands are extremely important natural resources which provide multiple stormwater benefits, including groundwater recharge, flood control, and stream channel erosion protection. They are easily impacted by development unless careful planning and management are conducted.

Wetlands can be severely degraded by stormwater discharges from urban development due to pollutants in the runoff and also due to disruption of natural hydrologic functioning of the wetland system. Changes in water levels and the frequency and duration of inundations are of particular concern. This requirement ensures wetlands are protected.

### **3.4.9 Minimum Requirement #9: Operation and Maintenance**

An Operation and Maintenance (O&M) Manual that is consistent with the provisions in Chapter 4 of this Volume shall be provided for all proposed stormwater BMPs at the time construction plans are submitted for review. The party (or parties) responsible for maintenance and operation shall be identified.

For private facilities, a copy of the O&M Manual shall be retained onsite or within reasonable access to the site, be made available for review by the City staff, and shall be transferred with the property to the new owner. A covenant and easement agreement is required for all proposed private stormwater facilities to ensure proper maintenance and access. The document shall be recorded on title. For public facilities, a copy of the O&M manual shall be retained by the appropriate department.

For all facilities (public and private), a log of maintenance activities outlining all inspections and routine or corrective actions completed shall be kept and be available for inspection by the City.

#### **3.4.9.1 Objective**

To ensure that stormwater control facilities are adequately maintained and operated properly.

#### **3.4.9.2 Supplemental Guidelines**

Inadequate maintenance is a common cause of failure for stormwater control facilities. The description of each BMP in Volumes 2, 3, 5 and 6 includes a section on maintenance. Appendix C of Volume 1 includes a schedule of maintenance standards for drainage facilities.

### **3.4.10 Minimum Requirement #10: Offsite Analysis and Mitigation**

As required by the Minimum Requirements of this Chapter and the Watershed Specific Requirements of Chapter 2, development projects that discharge stormwater offsite shall submit as part of their Stormwater Site Plan and Report an offsite analysis that assesses the potential offsite impacts of stormwater discharge.

#### **3.4.10.1 Qualitative Analysis**

All project applicants required to submit a Stormwater Site Plan shall perform and submit a qualitative analysis of each upstream system entering a site (run-on) and each downstream system leaving a site (run-off). The qualitative analysis shall extend downstream for the entire flowpath, from the project site to the receiving water, or up to one-quarter mile, whichever is less. The upstream analysis shall identify and describe points where water enters the site and the tributary area. A basin map delineating the onsite and offsite basins tributary to the site shall be provided. The basin map shall be to a defined scale. The City's GovME website may be used as a base for the basin map, and to obtain contours and existing stormwater facility information. However, field verification may be required.

Upon review of this analysis, the City may require a qualitative analysis further downstream, mitigation measures adequate to address the problems, or a quantitative analysis, depending upon the presence of existing or predicted flooding, erosion, or water quality problems, and on the proposed design of the onsite drainage facilities. Details on how to perform this analysis are located in Volume 1, Chapter 4 and Volume 1, Appendix B.

#### **3.4.10.2 Quantitative Analysis**

Projects that impact the downstream system by increasing the amount of stormwater runoff to the downstream private or public stormwater system may be required to complete a quantitative downstream analysis of the downstream system to ensure the system is appropriately sized before a connection to the system will be allowed. The type of analysis required shall be based upon the project impacts as described in Table 1 - 1 below. Environmental Services may require different or additional analyses than those represented in Table 1 - 1 based upon project impacts.

**Table 1 - 1: Quantitative Analysis Determination**

Increase in Surface Area Contributing to Downstream System	Pipe Size within ¼ mile downstream of the project	Required Analysis
< 5,000 SF	Any size	None
≥ 5, 000 SF and < 10,000 SF	≥ 12" φ	None
≥ 5, 000 SF and < 10,000 SF	< 12" φ	Single Segment Capacity Analysis (Vol. 3, Sec. 9.3.2) <u>and</u> Inlet and Gutter Capacity Analyses (Vol. 3, Sec. 9.4 and 9.5) (as applicable), OR City-Wide Capacity Model* (Vol. 1, Sec. 3.4.10.3) <u>and</u> Inlet and Gutter Capacity Analyses (Vol. 3, Sec. 9.4 and 9.5) (as applicable)
≥ 10, 000 SF	≥ 12" φ	Single Segment Capacity Analysis (Vol. 3, Sec. 9.3.2) <u>and</u> Inlet and Gutter Capacity Analyses (Vol. 3, Sec. 9.4 and 9.5) (as applicable), OR City-Wide Capacity Model* (Vol. 1, Sec. 3.4.10.3) <u>and</u> Inlet and Gutter Capacity Analyses (Vol. 3, Sec. 9.4 and 9.5) (as applicable)
≥ 10, 000 SF	< 12" φ	Full Backwater Analysis (Vol. 3, Sec. 9.3.3) <u>and</u> Inlet and Gutter Capacity Analyses (Vol. 3, Sec. 9.4 and 9.5), OR City-Wide Capacity Model* (Vol. 1, Sec. 3.4.10.3) <u>and</u> Inlet and Gutter Capacity Analyses (Vol. 3, Sec. 9.4 and 9.5)
Any Size	Connecting to a City-owned and identified trunk main	None

\*For City-Owned Pipes Only

### 3.4.10.3 City-Wide Capacity Modeling

The City of Tacoma, Environmental Services is currently in the process of modeling the entire City of Tacoma stormwater system for capacity. If the project is located where the City has developed a capacity model, the applicant may not be required to complete a Single Segment Capacity Analysis or Full Backwater Analysis. The applicant should contact the City of Tacoma Environmental Services to determine if a capacity model has been developed for a specific discharge location. The applicant may elect to provide their own model per Volume 1, Table 1 - 1 instead of utilizing the results of the City of Tacoma model. If the applicant is required to mitigate to meet Infrastructure Protection and chooses to upsize the downstream system, the applicant is responsible to determine the required size of the upgrades per a Full Backwater Analysis.

### 3.4.10.4 Mitigation – Infrastructure Protection

Applicants required to complete a qualitative or quantitative analysis per Vol.1, Sec. 3.4.10.1 or Vol. 1, Sec. 3.4.10.2 or as otherwise determined by the City as having capacity issues and have projects that discharge stormwater directly or indirectly as follows shall provide flow control per Minimum Requirement #7 – Infrastructure Protection (Vol. 1, Sec. 3.4.7.3).

- To a conveyance system without capacity to convey the fully developed design event as determined through a full backwater quantitative downstream analysis and/or Inlet and Gutter Capacity Analyses per Volume 1, Section 3.4.10; or
- To a capacity problem downstream of the project as determined by Environmental Services using City-Wide Capacity Modeling per Vol. 1, Sec. 3.4.10.2; or
- To a manmade conveyance system (ditch, swale, etc.) which has not been adequately stabilized to prevent erosion as determined by the downstream qualitative analysis per Vol. 1. Sec. 3.4.10.2 or as determined by Environmental Services.

#### **3.4.10.5 Objective**

To identify and evaluate offsite water quantity, erosion, slope stability, and drainage impacts that may be caused or aggravated by a proposed project, and to determine measures for preventing impacts and for not aggravating existing impacts. Aggravating shall mean increasing the frequency of occurrence and/or severity of a problem. Some of the most common and potentially destructive impacts of land development are erosion of downgradient properties, localized flooding, and slope failures. These can be caused by increased surface water volumes and changed runoff patterns. The applicant shall also evaluate types and locations of surface run-on to the project site. These must be safely conveyed across the project site.

## **3.5 Exceptions/Adjustments**

### **3.5.1 Exceptions to the Minimum Requirements**

Exceptions to the Minimum Requirements may be requested, in writing, in accordance with TMC 12.08.095 to allow a waiver of a requirement. Public notice of application for an exception, decision and written findings that document the determination to grant an exception will be published in accordance with TMC 12.08.095, with an opportunity for public comment.

Exceptions must meet the following criteria:

- Application of the Minimum Requirement(s) would impose a severe and unexpected economic hardship; and
- The exception will not increase risk to the public health and welfare, nor be injurious to other properties in the vicinity and/or downstream, and to the quality of waters of the state; and
- The exception is the least possible exception that could be granted to comply with the intent of the Minimum Requirements.

Applications for an exception from the Minimum Requirements of TMC 12.08.090 must be made in writing and include the following information:

- The current (pre-project) use of the site; and
- How application of the Minimum Requirement(s) restricts the proposed use of the site compared to the restrictions that existed prior to the adoption of the Minimum Requirements; and
- The possible remaining uses of the site if the exception were not granted; and
- The uses of the site that would have been allowed prior to the adoption of the Minimum Requirements; and
- A comparison of the estimated amount and percentage of value loss as a result of the Minimum Requirements versus the estimated amount and percentage of value loss as a result of requirements that existed prior to adoption of the Minimum Requirements; and
- The feasibility for the owner to alter the project to apply the Minimum Requirements.

The decision to grant an exception is within the sole discretion of the City and an exception will only be approved to the extent it is necessary. New or additional requirements may be imposed on the project to offset or mitigate harm that may be caused by approving the exception. The applicant may be required to submit a licensed engineer's report, plans, and/or analysis along with the request. The Washington State Department of Transportation Highway Runoff Manual, Chapter 2, Appendix A, presents methods that may be useful for evaluating economic hardship and human health criteria. The approval of an exception shall not be construed to be an approval of any violation of any other provisions of the City's Municipal Code, or of any other valid law of any governmental entity having jurisdiction.

### **3.5.2 Adjustments**

Adjustments to the Minimum Requirements may be requested, in writing, to allow a reduction or modification of a requirement or to permit an alternative requirement. The applicant shall submit all requests to Environmental Services. Applications for an adjustment to a Minimum Requirement shall be made in writing and include documentation that outlines how:

- The adjustment provides substantially equivalent environmental protection; and

- Based on Sound Engineering Practices, the objectives of safety, function, environmental protection and facility maintenance are met.

The decision to grant an adjustment is within the sole discretion of the City and an adjustment will only be approved to the extent it is necessary. New or additional requirements may be imposed on the project to offset or mitigate harm that may be caused by approving the adjustment. The applicant may be required to submit a licensed engineer's report, plans, and/or analysis along with the request. The approval of an adjustment shall not be construed to be an approval of any violation of any other provisions of the City's Municipal Code, or of any other valid law of any governmental entity having jurisdiction.

### **3.5.3 Other Exceptions**

Exceptions to other requirements in this manual, including project specific design exceptions, but not including exceptions and adjustments to the Minimum Requirements or exceptions and adjustments that would alter the facility function, may be requested in writing to Environmental Services. The exception request must describe why the requirement in the manual cannot be met and why it will not likely affect downstream properties, the quality of waters of the state, the facility function, and the health and welfare of the public. Environmental Services will make the final determination of whether to approve or deny the exception and inform the applicant.

**This page intentionally left blank**

## Chapter 4 Preparation of Stormwater Site Plans

The Stormwater Site Plan (SSP) is a comprehensive report and drawing set containing all the technical information and analysis necessary to evaluate projects for compliance with the stormwater requirements. The drawing set is typically referred to as the Civil Plan Set or the Site Plan, depending upon project size. The contents of the Stormwater Site Plan will vary with the type and size of the project, and individual site characteristics. The scope of the Stormwater Site Plan also varies depending on the applicability of Minimum Requirements (see Section 3.4). Typical Stormwater Site Plans will contain both a report and detailed plans.

This chapter describes the contents of a Stormwater Site Plan and provides a general procedure for how to prepare the plan. The goal of this chapter is to provide a framework for uniformity in plan preparation. Such uniformity will promote predictability and help expedite review. Properly drafted engineering plans and supporting documents will also facilitate the operation and maintenance of the proposed system after construction is complete.

State law requires that engineering work be performed by or under the direction of a professional engineer licensed to practice in Washington State. Plans and documents that include an engineered design shall be prepared by or under the direction of a licensed engineer. Construction Stormwater Pollution Prevention Plans (SWPPPs) that involve engineering calculations must also be prepared by or under the direction of a licensed engineer. All engineered documents shall be signed, stamped and dated prior to review by the City.

### 4.1 Stormwater Site Plan Checklist

To aid the design engineer, this chapter is formatted as a checklist containing submittal requirements. This checklist shall be completed by the design engineer and included within the SSP. All items included in the checklist must be addressed as part of any stormwater site plan as applicable. The City recommends the design engineer follow the order and structure of the checklist to facilitate review, which in turn will expedite permit issuance.

#### ***Title Page***

- Provide applicant, engineer and property owner information including name, address, telephone number and email address for all parties.
- Provide date of document preparation.

#### ***Table of Contents***

- Include a Table of Contents.

#### ***List of Figures***

- Include a List of Figures.

#### ***Numbering***

- Number all pages, figures, maps and appendices.



## Chapter 1 – Project Overview

The project overview must provide a general description of the project including the existing condition of the site, the proposed developed condition of the site, the site area, and the extent of the improvements.

- Identify type of permit requested by the City and all associated permit numbers
- Identify permits required by other agencies (e.g. hydraulic permits, Army Corps 404 permits, wetlands, etc.)
- Note if a NPDES Industrial or Sand and Gravel Stormwater General Permit exists or is required for the site. The online application for Industrial Permits is available at: <http://www.ecy.wa.gov/programs/wq/stormwater/industrial/permitteehelp.html>. The online application for Sand and Gravel Permits is available at: <http://www.ecy.wa.gov/programs/wq/sand/permit.html>.
- Identify the project location (including address and parcel number).
- Brief description of project to include the following:
  - Current and proposed condition/land-use
  - Size of parcel
  - Watershed
  - Critical areas on or adjacent to the project site

Reference appropriate Sections/Chapters/Appendices of the Stormwater Site Plan Report for detailed descriptions.

## Chapter 2 – Existing Condition Summary

The Existing Condition Summary is intended to provide a complete understanding of the project site in its existing condition and must be based on thorough site research and investigation.

- Describe, discuss and identify the following for the project site in its existing condition:
  - Topography
  - Land use and ground cover
  - Natural and man-made drainage patterns
  - Points of entry and exit for existing drainage to and from the site
  - Ultimate discharge location (i.e., Commencement Bay, Puyallup River, wetland, closed depression, etc.)
  - Any known historical drainage problems such as flooding, erosion, etc.
  - Existing utilities (storm, water, sewer)
  - Areas with high potential for erosion and sediment deposition
  - Locations of sensitive and critical areas (i.e. vegetative buffers, wetlands, steep slopes, floodplains, geologic hazard areas, streams, creeks, ponds, ravines, springs, etc.)
  - Existing fuel tanks
  - Groundwater wells onsite and/or within 100 feet of the site
  - Septic systems onsite and/or within 100 feet of the site
- Identify difficult site conditions.
- State whether the project is located in an aquifer recharge area or wellhead protection area as defined by the Tacoma-Pierce County Health Department, the Environmental Protection Agency or by the City.
- Identify any Superfund areas in the vicinity, and state whether they are tributary to, or receive drainage from, the project site.

- Identify any specific requirements included in a basin plan for the area.
- Include references to relevant reports such as basin plans, flood studies, groundwater studies, wetland designations, sensitive area designations, environmental impact statements, environmental checklists, lake restoration plans, water quality reports, etc. Where such reports impose additional conditions on the Proponent, state these conditions and describe any proposed mitigation measures.
- Include a Grading Plan.
- Include a soil report. See Volume 3, Appendix B for requirements of a soils report and to determine when a soils report is needed.
- Soil reports should be contained in Appendix A of the Stormwater Site Plan or as a separate document.
- Describe the location of the 100-year flood hazard zone.
- Other information as necessary to fully describe the existing site and its surroundings.

### **Chapter 3 – Offsite Analysis**

A qualitative analysis is required for every project. See Volume 1, Section 3.4.10 to determine when a quantitative analysis is required. Detailed calculations will be contained in Appendix B of the Stormwater Site Plan. Volume 1, Chapter 4 of the SWMM describes the Offsite Analysis.

#### ***Qualitative Analysis***

The City requires a qualitative discussion of the offsite upstream and downstream system for all projects. The qualitative analysis shall extend downstream for the entire flowpath, from the project site to the receiving water, or up to ¼ mile, whichever is less. Upon review of this analysis, the City may require a qualitative analysis further downstream, mitigation measures deemed adequate to address any identified problems, or a quantitative analysis, depending upon the proposed design of the onsite drainage facilities and the presence of existing or predicted flooding, erosion, or water quality problems.

- Review all available plans, studies and maps pertaining to the offsite study area.
- Provide a basin map which:
  - Defines onsite and offsite basin tributary to the site
  - Is on a defined scale (the City's GovME site may be used as a basis for the map, as well as to obtain contours and existing stormwater facility information)
- Investigate the upstream system, including the points where water enters the site and the tributary area.
- Investigate the drainage system ¼ mile downstream from the project by site visit, including the following items:
  - Problems reported or observed during the resource review
  - Existing/potential constrictions or capacity deficiencies in the drainage system
  - Existing/potential flooding problems
  - Existing/potential overtopping, scouring, bank sloughing or sedimentation
  - Upland erosion impacts, including landslide hazards
  - Significant destruction of aquatic habitat (e.g. siltation, stream incision)
  - Existing public and private easements through the project site and their corresponding widths
  - Qualitative data on features such as land use, hard surface, topography, soils, presence of streams and wetlands.

- Information on pipe sizes, channel characteristics and drainage structures
- Verification of tributary drainage areas
- Date and weather at the time of the inspection
- Impacts to surface water, groundwater, or sediment quality
- Ultimate discharge location even if beyond ¼ mile (i.e. Commencement Bay, Puyallup River, wetland, closed depression, etc)
- Describe the drainage system and its existing and predicted problems through observation. Describe all existing or potential problems as listed above (e.g. pooling water or erosion). The following information shall be provided for each existing or potential problem:
  - Magnitude of or damage caused by the problem
  - Names and concerns of the parties involved
  - Current mitigation of the problem
  - Possible cause of the problem
  - Whether the project is likely to aggravate the problem or create a new one

### ***Quantitative Analysis***

See Volume 1, Section Section 3.4.7 to determine when a quantitative analysis is required and type of analysis.

- Include all model assumptions, outputs, and equations used.
- Clearly describe tailwater assumptions.
- Summarize results in text.
- Include copies of all calculations in Appendix B of the SSP.
- Discuss potential fixes for capacity problems.
- Provide hydraulic gradeline.
- ¼ mile field survey, if required by Environmental Services.
- Include all standardized graphs and tables, and indicate how they were used.
- Provide details on references and sources of information used.

## **Chapter 4 – Permanent Stormwater Control Plan**

Chapter 4 will contain the information used to select, size and locate permanent stormwater control BMPs for the project site. Previous stormwater reports may be referenced. Environmental Services may request submission of all reference reports in their entirety. The Stormwater Control Plan shall contain the following sections, as applicable:

### ***Section 1 - Threshold Discharge Areas and Applicable Requirements for Treatment, Flow Control, and Wetlands or other Critical Areas Protection***

Complete the following steps in order to determine the applicable Minimum Requirements.

- Outline the threshold discharge area(s) of the project site. Include a map labeling the threshold discharge area(s). Please see the Glossary of the SWMM for appropriate definitions.
- Complete all applicable portions of the following table for each threshold discharge area. Compare the values in the Table 1 - 2 with Section 3.3 and use the flow charts (Figure 1 - 5 to Figure 1 - 9) to determine which requirements apply to your project site. Note any watershed specific requirements, per Volume 1, Section 3.3.7.

**Table 1 - 2: Project Threshold Worksheet**

Description <sup>a</sup>	Onsite	Offsite	Total
<b>Existing Conditions</b>			
Total Project Area <sup>b</sup> (ft <sup>2</sup> )			
Existing hard surface (ft <sup>2</sup> )			
Existing vegetation area (ft <sup>2</sup> )			
<b>Existing Conditions</b>			
Total Project Area <sup>b</sup> (ft <sup>2</sup> )			
Amount of new hard surface (ft <sup>2</sup> )			
Amount of new pollution generating hard surface (PGHS) <sup>c</sup> (ft <sup>2</sup> )			
Amount of replaced hard surface (ft <sup>2</sup> )			
Amount of replaced PGHS <sup>d</sup> (ft <sup>2</sup> )			
Amount of new plus replaced hard surface (ft <sup>2</sup> )			
Amount of new + replaced PGHS (ft <sup>2</sup> )			
Amount of existing hard surfaces converted to vegetation (ft <sup>2</sup> )			
Amount of Land Disturbed (ft <sup>2</sup> )			
Vegetation to Lawn/Landscaped (acres)			
Native Vegetation to Pasture (acres)			
Existing vegetation area to remain (ft <sup>2</sup> )			
Existing hard surface to remain unaltered (ft <sup>2</sup> )			
Value of proposed improvements (\$)			
Assessed Value of Existing Site Improvements(\$)			
Amount to be Graded/Filled (cubic feet)			

a. All terms are defined in the SWMM glossary.

b. The total project area in the existing condition should typically match the total project area in the proposed condition.

c. The “amount of new PGHS” should be part of or all of “amount of new hard surfaces”.

d. The “amount of replaced PGHS” should be part of or all of “amount of replaced hard surfaces”

**Section 2 - Pre-Developed or Existing Site Hydrology**

- Describe in as much detail as possible the predeveloped or existing site hydrology as applicable. Provide a list of assumptions and site parameters for the predeveloped or existing condition.
- Identify all sub-basins within, or flowing through, the site. Use consistent labeling for all sub-basins throughout figures, calculations and text.

- For each sub-basin, identify current land use, acreage, hydrologic soil group and land use to be modeled under predeveloped or existing conditions. The format used in Volume 1, Appendix B is recommended.
- Provide justification for land uses type. (Note: See MR #7 as applicable).
- Provide a basin map drawn to scale showing the following:
  - Delineation and acreage of areas contributing runoff to the site, including land use type
  - Delineation and acreage of areas where stormwater will runoff from the site, including land use type
  - The location of basin discharge and ultimate discharge
  - All natural streams and drainage features onsite or directly abutting the project site
  - The limits of development
- Summarize output data from the predeveloped or existing condition. The format used in Volume 1, Appendix B is recommended.
- Include completed Hydraulic Analysis worksheet (see Volume 1, Appendix B) and hydrologic calculations in Appendix D of the SSP.
- For WWHM models, provide model files electronically. Do not provide printouts of WWHM model outputs.
- Provide other information as necessary to provide a detailed description of the basins and subbasins affected by the project.

### ***Section 3 - Developed Site Hydrology***

Describe in as much detail as possible the proposed developed site hydrology.

- Provide a list of assumptions and site parameters for the developed condition.
- Identify all sub-basins within, or flowing through, the site. Use consistent labeling for all sub-basins throughout figures, calculations and text. If boundaries of the basin are modified by the project, clearly show the new boundaries on the map.
- For each sub-basin, identify current land use, acreage, hydrologic soil group and land use to be modeled under developed conditions. The format used Volume 1, Appendix B is recommended.
- Provide a basin map drawn to scale showing the following:
  - Delineation and acreage of areas contributing runoff to the site, including land use type
  - The location of basin discharge and ultimate discharge
  - All natural streams and drainage features
  - The limits of development
- Final grade site plan showing finish floor elevations, where appropriate.
- Summarize output data from the developed condition. The format used in Volume 1, Appendix B is recommended.
- Include completed Hydraulic Analysis worksheet (see Volume 1, Appendix B) and hydrologic calculations in Appendix D of the SSP.
- For WWHM models, provide model files electronically. Do not provide printouts of WWHM model outputs.
- Provide other information as necessary to provide a detailed description of the basins and subbasins affected by the project.

### ***Section 4 - Performance Goals and Standards***

Use the information obtained in Chapter 4, Section 1 of the report to complete this section.

- Include applicable flow chart (Figure 1 - 5, Figure 1 - 6, Figure 1 - 8, Figure 1 - 8, or Figure 1 - 9) with decision path clearly marked and supported. If flow control facilities are required, indicate that they are required.
- If water quality treatment is required, provide treatment type required per Volume 5.
- If flow control is required, provide a confirmation of the flow control standard being achieved (the Standard Requirement - Forested, Standard Requirement - Existing, or the Infrastructure Protection Requirement).
- Provide basin specific requirements.
- Identify South Tacoma Groundwater Protection District requirements, if applicable.

### **Section 5 – Onsite Stormwater Management**

- Summarize results of onsite stormwater management feasibility results. Describe the infeasibility criteria that cannot be met. Summarize associated soils report if applicable.
- Identify type and size of proposed onsite stormwater facility.
- Provide a drawing of the proposed onsite facility and its appurtenances, including:
  - Dimensions
  - Location of inflow, outflow, and overflow
  - Location of the facility on the project site.
  - Pipe material and diameter

### **Section 6 - Flow Control System (where required)**

Provide as much detailed information as possible to describe the proposed flow control system.

- Identify sizing used.
- Summarize model results. Include an explanation of all assumptions made, equations used, input parameters, etc.
- Describe proposed flow control system and appurtenances, including size, type and characteristics of storage facility and control structure.
- Provide a drawing of the flow control facility and its appurtenances, including:
  - Dimensions
  - Location of inflow, outflow, and overflow
  - Orifice/restrictor sizes and elevations
  - Control structure location
  - Location of the facility on the project site
  - Applicable water surface elevations
- Include Hydraulic Analysis Worksheet per Volume 1, Appendix B, calculations, and computer printouts (including stage storage tables) for the flow control system to be included in Appendix D of the SSP.
- Include all WWHM model files electronically. Do not provide printouts of WWHM model outputs.
- Provide all applicable manufacturer information in Appendix E of the SSP.

### **Section 7 - Water Quality System (where required)**

- Identify the sizing method used.
- Summarize model results. Include an explanation of all assumptions made, equations used, etc.

- Identify treatment methods used, including size, type and characteristics of treatment facility and appurtenances.
- Provide a drawing of the treatment facility and its appurtenances, including:
  - Dimensions
  - Inlet/outlet sizes and elevations
  - Location and size of bypass
  - Location of the facility on the project site
  - Appurtenances/fittings
- Calculations for the water quality design storm and facility sizing calculations must be included in Appendix D of the SSP. Provide all WWHM files electronically. Do not provide printouts of WWHM model outputs.
- Where appropriate, include manufacturer's specifications in Appendix E of the SSP.

### **Section 8 - Conveyance System Analysis and Design**

- Provide a site plan showing the conveyance system including:
  - Existing conveyance system components including all pipes, culverts, channels, swales, catch basins, manholes, etc. Include sizes, types, and slopes of all components.
  - Proposed conveyance system components including all pipes, culverts, channels, swales, catch basins, manholes, etc. Include sizes, types, and slopes of all components.
  - Invert elevations of all proposed and existing components.
  - All crossing information to ensure vertical and horizontal separation (this may require a profile view).
- Describe capacities, design flows and velocities for each reach.
- Include conveyance calculations in Appendix D of the SSP. Analysis shall be based on Volume 3, Chapter 9 of the SWMM.
- Other information as necessary to fully describe the existing and proposed conveyance system.

### **Chapter 5 – Discussion of Minimum Requirements and Site Layout**

Chapter 5 is intended as a checklist for the applicant and reviewer to verify that the applicable Minimum Requirements have been met within the project submittal.

- List the Minimum Requirements that apply to the project.
- Discuss how the project satisfies each Minimum Requirement.
- Discuss the use of the following low impact development principles. The following principles should be used where feasible:
  - Minimization of land disturbance by fitting development to the natural terrain.
  - Minimization of land disturbance by confining construction to the smallest area feasible and away from critical areas.
  - Preservation of natural vegetation.
  - Locating impervious surfaces over less permeable soils.
  - Clustering Buildings
  - Minimizing Impervious Surfaces

## Operation and Maintenance Manual

The Operation and Maintenance Manual shall be a stand-alone document for the project owner once the project is complete. Please see Volume 1, Appendix C of the SWMM for additional information. The Operation and Maintenance Manual must include:

- A narrative description of the stormwater facilities.
- An 11 x 17 inch site plan, with the locations of the stormwater facilities (including conveyance) prominently noted. This is needed to enable the Operation and Maintenance Manual to be a stand-alone document. Not required for facilities that will be maintained by the City and located in the public right-of-way because the facility plans are uploaded to the City of Tacoma govme.org website.
- Detail drawings of the proposed facilities including overall dimensions and locations of inflow, bypass, and discharge. Not required to be included in the Operation and Maintenance Manual for City owned facilities.
- The person or organization responsible for maintenance of the onsite storm system, including the phone number and current responsible party. For facilities that will be maintained by the City and located in the City right-of-way, the responsible party shall be the City of Tacoma - Environmental Services - (253) 591-5585.
- Where the Operation and Maintenance Manual is to be kept. Note that it must be made available to the City for inspection. The Operation and Maintenance Manual shall be onsite prior to Certificate of Occupancy. For facilities that will be maintained by the City of Tacoma located in the public right of way - the operation and maintenance manual is kept at the City of Tacoma Wastewater Treatment Plant.
- A description of each stormwater facility, including what it does and how it works. Include any manufacturer's documentation and recommendations. For City maintained facilities located in the public right of way, do not include manufacturer's documentation and recommendations as part of the submittal.
- A description of all maintenance tasks and the frequency of each task for each facility. Include any manufacturer's recommendations. For City maintained facilities located in the Public Right of Way, do not include this with the submittal.
- A sample maintenance activity log indicating emergency and routine actions to be taken. For City owned facilities located in the public right of way, do not include this with the submittal.
- A cost estimate for maintenance of each facility.

## Construction Stormwater Pollution Prevention Plan (SWPPP)

The Construction Stormwater Pollution Prevention Plan shall be a stand-alone document.

- Short-Form – Please refer to Volume 2 – Appendix B of the SWMM for a complete checklist, or
- Formal/Long-Form – Please refer to Volume 2 – Section 2.3 of the SWMM for a complete checklist.

## Appendices

- Appendix A – Operations and Maintenance Manual – See Description Above. In the SSP reference separate report.
- Appendix B – Construction Stormwater Pollution Prevention Plan – See Description Above. In the SSP reference separate report.



- Appendix C – Submittal Requirements Checklist – A copy of the checklist shall be submitted as part of SSP.
- Appendix D – Hydraulic Analysis Worksheet – A copy can be found in Volume 1, Appendix B of SWMM.
- Appendix E – Other reports and Manufacturer’s Information as required and applicable.

## Required Drawings

Project drawings shall be provided and include the following as applicable for the project. The drawings are not required to be included in the Stormwater Site Plan Report. They are typically submitted as separate documents.

- The first sheet or cover sheet shall include:
  - Name, address, email and telephone number of the applicant, agent or owner.
  - Name, address, email and telephone number of the person preparing the plans.
  - Name, address, email and telephone number of the Project Engineer.
  - Building Permit Number (an 11 digit number starting with 40000\_\_\_\_\_) or Work Order Permit Number (an 11 digit number starting with 60000\_\_\_\_\_).
  - Permit numbers for other City of Tacoma Permits associated with the project (Work Order, Grade and Fill, Building, Demolition, Final Plat, etc.).
  - North arrow
  - Vicinity Map showing project boundaries and of sufficient clarity to locate the property; streets with street names, shorelines, if any; city limit boundaries, if any.
  - Parcel numbers and legal description of the project site.
  - Property boundaries, dimensions and area (in square feet or acres).
  - Datum for the project.
  - Legend, if symbols are used that are not labeled on the plan.
- At least one sheet must contain a plan view of the entire project site. In the event the project site is sufficiently large that detailed drainage plans on any given sheet do not encompass the entire project site, then the sheet containing the plan view of the entire site must serve as an index to subsequent detailed plan sheets.
- All sheets shall contain a scale and north arrow.
- The overall plan view shall be no smaller than 1" = 100' (horizontal). Recommended scales for individual sheets are 1" = 20' (Horizontal); 1" = 5' or 1" = 10' (Vertical).
- Cross sections shall be provided for roadways, including access roads, and stormwater facilities.
- Identify FEMA flood zones
- Identify any onsite or adjacent critical areas, associated buffers (e.g. wetlands, watercourses and natural drainage channels, water bodies, steep slopes, streams, shorelines etc) significant trees and natural vegetation easements, if any.
- Existing Site Information Including:
  - Existing topography for the site and extending 50' beyond project boundaries. Existing topography for adjacent rights-of-way for the full width of right-of-way.
    - Contours at a maximum 5' vertical elevation intervals.
    - Engineered designs require field verification of contours (field survey).
    - Depending on the site, a standalone topographic survey sheet may be required.
  - Existing lot boundaries, right of way boundaries, tracts, and easements. Documentation of public and private easements may be required.

- Existing structures, including all structures within 50 feet of project boundaries, including:
  - All hard surfaces such as roads, parking lots, driveways, patios, buildings, garages, walkways, etc.
  - Existing structures to be removed.
  - Existing storage tanks (above and below ground).
  - Existing oil water separators, grease interceptors or other sanitary pretreatment facilities.
  - Existing wells, sanitary sewer systems, septic tanks and drain fields onsite and/or within 50' of the project boundaries.
- Existing site access points.
- Existing utilities including:
  - Any franchised utilities located above or below ground.
  - Drainage facilities, which transport surface water onto, across, or from the project site.
    - Invert or flow line elevation of existing drainage pipes, culverts, and channels.
    - Rim elevations of any existing conveyance structures (catch basins, manholes, etc.)
  - Invert elevations for connections to existing public utilities.
  - Existing sanitary sewers, including private sanitary laterals, showing their connections to the main.
- Proposed site information, including:
  - Finished grade contours for the site showing catch points to existing topography at the limits of grading.
    - Contours at a maximum 5' vertical elevation intervals.
    - Engineered designs require field verification of contours (field survey).
    - Depending on the site, a standalone topographic survey sheet may be required.
  - Contours, spot elevations and flow arrows to clearly indicate how driveways, parking areas and other hard surfaces will be graded.
  - Proposed lot boundaries, right of way boundaries, tracts, and easements. Documentation of public and private easements may be required.
  - Proposed structures including:
    - Proposed storage tanks (above and below ground).
    - Location and details for oil water separators, grease interceptors or other sanitary pre-treatment facilities.
    - Proposed hard surfaces such as roads, parking lots, driveways, patios, buildings, garages, walkways, etc.
    - Proposed drainage structures, including all flow control and water quality devices. Details shall be provided for all proposed drainage structures for which there is insufficient information in the plan view.
  - Proposed utilities including:
    - Exact line and grade of all proposed utilities at crossings with other utilities.
    - Any franchised utilities located above or below ground
    - Drainage facilities, which transport surface water onto, across, or from the project site.
      - Invert or flow line elevation of proposed drainage pipes, culverts, and channels
      - Rim elevations of any proposed conveyance structures (catch basins, manholes, etc.)
    - Invert elevations for connections to public utilities.

- Proposed sanitary sewers, including private sanitary laterals, showing their connections to the main.
- Finish floor elevations for all proposed buildings.
- Plan views of drainage conveyance facilities for which there is no accompanying profile view shall include the following information: pipe sizes, pipe types and materials, lengths of runs, pipe slope and exact locations of pipes or channels, structure identifier (e.g. catch basin/manhole number), type of structure (e.g. Type 2 CB), exact location of structures (e.g. station and offset, or dimensioning), invert elevations in/out of structures, and top elevations of structures. Notes and/or labels shall be included referencing details, cross-sections, profiles, etc.
- In existing and proposed rights-of-way, drainage conveyance facilities shall be shown in profile view. Profile views shall include:
  - Existing and finish grades.
  - Proposed drainage pipes, channels and structures.
  - Existing underground utilities where such utilities cross proposed drainage facilities.
  - Profile views shall include the following information: pipe sizes, pipe types and materials, lengths of runs, gradients and exact locations of pipes or channels, structure identifier (e.g. catch basin/manhole number), type of structure (e.g. Type 2 CB), exact location of structures (e.g. station and offset, or dimensioning), invert elevations in/out of structures, and top elevations of structures. Plan and profile views shown on the same sheet shall be aligned, duplicate information should be avoided for plan and profile views on the same sheet.
- Location of and details associated with all stormwater mitigation facilities. If the predesigned systems from the SWMM are used, the details from the SWMM shall be included.

### ***Temporary Erosion and Sedimentation Drawings***

The Temporary Erosion and Sedimentation Drawings shall include the following information, at a minimum:

- Vicinity map with roads and waters of the state within one mile of the site
- Address, Parcel Number, and Street name labels
- Erosion and Sediment Control Notes, at a minimum, those contained in SWMM Volume 2, Appendix A, as applicable
- Name, address and 24-hour contact telephone number(s) of the designated emergency contact person. The emergency contact information may be supplied at the pre-construction meeting.
- Name, address, and phone number of the Erosion and Sediment Control Lead (ESC), Certified Erosion and Sediment Control Lead (CESCL), or Certified Professional in Erosion and Sediment Control (CPESC) as applicable
- Name, address, telephone number, and email address of the project owner and the Project Engineer.
- Detailed listing of the construction sequence.
- Detailed listing of the phasing of any erosion and sedimentation control work
- Legal description of subject property.
- North Arrow
- Boundaries of existing vegetation, e.g. tree lines, pasture areas, etc.
- Areas of potential erosion problems.
- Onsite or adjacent surface waters, critical areas and associated buffers.

- FEMA base flood boundaries and Shoreline Management boundaries, (if applicable).
- Existing and proposed contours.
- Drainage basins and direction of flow for individual drainage areas.
- Label final grade contours and identify developed condition drainage basins.
- Delineation of areas that are to be cleared and graded.
- Areas where vegetation will be undisturbed.
- All cut and fill slopes indicating top and bottom of slope catch lines.
- Soil types, together with the location of any soil test pits or infiltration test sites.
- Location of stockpiles, haul roads and disposal sites.
- Locations for swales, interceptor trenches, or ditches.
- All temporary and permanent drainage pipes, ditches, or cutoff trenches required for erosion and sediment control.
- Provide minimum slope and cover for all temporary pipes or call out pipe inverts.
- Show grades, dimensions, and direction of flow in all ditches, swales, culverts and pipes.
- Details for bypassing offsite runoff around disturbed areas.
- Locations and outlets of any dewatering systems
- Locations of all existing and proposed channels, swales or drainage pipes which either convey offsite stormwater through or route stormwater around the construction area.
- Locations of all ESC facilities with dimensions and details as appropriate.
- When sedimentation ponds and traps are proposed, at least one cross section detail shall be shown.
- Details and notes for mulching and revegetation, including detailed planting procedures, seed/plant specifications, and plant maintenance specifications.
- Any best management practices used that are not referenced in the SWMM shall be explained and illustrated with detailed drawings.
- Locations of BMPs to be used for the control of pollutants other than sediment, e.g. concrete wash water.
- Water quality sampling locations to be used for monitoring water quality on the construction site, if applicable.
- Description of inspection reporting responsibility, documentation, and filing.

## **4.2 Plans Required After Approval**

This section includes the specifications and contents required of those plans submitted after the City has approved the permit.

### **4.2.1 Revisions**

If the designer wishes to make changes or revisions to the originally approved permit submittal documents, the proposed revisions shall be submitted to the City prior to construction. The submittals shall include the following:

1. A revised Stormwater Site Plan Report to include the proposed changes.
2. Revised drawings showing all proposed changes.
3. Any other supporting information that explains and supports the reason for the change.

**NOTE:** *Submittals shall comply with Planning and Development Services and/or Environmental Services - Site Development Group requirements, as applicable.*

#### **4.2.2 Record Drawing Submittal**

If the project included construction of conveyance systems, treatment facilities, flow control facilities, or structural source control BMPs (i.e., this does not extend to construction of Onsite Stormwater Management BMPs unless required by Environmental Services), the applicant shall submit record drawings (“as-builts”) to the City when the project is completed. These shall be engineering drawings that accurately represent the project as constructed. Record Drawings shall show the invert and rim elevations to the nearest 0.01 foot for all storm structures. Record drawings shall be received and accepted after facility installation and prior to final inspection and/or closeout. As-built Stormwater Site Plan Reports may be required based upon the extent of the field changes. See the work order general notes for record drawing requirements for work order projects. Contact Environmental Services, Site Development Group for submittal format.

#### **4.2.3 Engineer’s Certification**

The Engineer of Record shall provide an Engineer’s Certification to the City of Tacoma after facility installation and prior to permit final inspection and/or closeout. The Engineer’s Certification shall include, as applicable:

1. The permit number.
2. Statements to attest:
  - a. That all stormwater facilities have been installed according to the approved permit documents.
  - b. Record drawings have been provided to the City electronically. See Section 4.2.2 for record drawing requirements.
  - c. The soils at the bottom of the infiltration facility are as indicated in the plans. The designer or soils professional that classified the soils will need to be onsite during construction to verify the soil types.
  - d. The Operations and Maintenance Manual is located onsite.

### **4.3 Land Use Submittal Requirements**

At the discretion of Environmental Services, the following items shall be submitted as part of the land use process:

- Preliminary Stormwater Site Plan.
  - The submittal for a land use action must include a feasible stormwater design that meets the requirements of this manual. A separate submittal and permit is required for construction. The submittal for a land use permit does not have to show a complete constructible design but must show a feasible stormwater design. A soils report and geotechnical report as applicable are typically required at the land use phase.
- Preliminary Utility Plan, which shall include:
  - Title block, including name of the proposed project/development.

- North arrow indicator, drawing scale.
- Project parcel number.
- The plan view of preliminary drainage plans – must be drawn at an engineering scale no smaller than 1" = 100'.
- Professional Engineer's seal, signed and dated, for an engineered system.
- Vicinity map showing project boundaries, streets with street names, shorelines (if any), city limit boundaries (if any), and distance to nearest intersection.
- Permit number(s) for this permit and all associated permits.
- Name, address and telephone number of project developer and property owner.
- Name, address and telephone number of licensed professional engineer.
- Symbol legend.
- Property boundaries, dimensions, and area (in square feet or acres).
- Contour lines, at maximum 5' intervals, with source of datum identified (GovME contours are acceptable).
- Adjoining street names and right-of-way widths.
- Existing conditions onsite (include all existing hard and vegetation surfaces and their applicable square footage).
- Proposed conditions onsite (include all proposed hard and vegetation surfaces and their applicable square footage).
- Show on plans and quantify in a table the proposed hard surfaces and disturbed areas, as shown in Table 1 - 3.
- Show how all stormwater runoff from the proposed accessway will be managed onsite or conveyed to the City system. Grading of accessways can be shown with spot elevations, a profile, and/or cross-section of the proposed accessway.
- Indicate how public street runoff will be prevented from entering the private drainage system.
- Show existing drainage facilities such as pipes, catch basins, channels, ponds, etc.
- Location of onsite and adjacent offsite wastewater treatment systems, such as septic tanks and drainfields.
- Existing and proposed utilities, with easements identified.
- Existing private storm sewer lines with easements identified.
- Offsite street and storm improvements.
- Established buffers, significant trees, and natural vegetation easements, if any.
- Natural drainage channels, wetlands, water bodies, etc.
- Areas where natural vegetation is to be left undisturbed.
- The location of onsite and adjacent offsite wells and underground storage tanks.
- An approximate plan for the collection and conveyance of stormwater through the project site. At a minimum, provide arrows showing the direction of proposed

stormwater flow and indicate the method of conveyance (pipe, ditch, biofiltration swale, overland flow, etc.).

- Proposed locations and sizes of stormwater quantity and quality control facilities, if required.
- Proposed sewer lines and side sewers.
- Proposed easement locations and widths.

Additional submittal requirements may be imposed by Environmental Services.

**Table 1 - 3: Project Threshold Worksheet**

Description <sup>a</sup>	Onsite	Offsite	Total
<b>Existing Conditions</b>			
Total Project Area <sup>b</sup> (ft <sup>2</sup> )			
Existing hard surface (ft <sup>2</sup> )			
Existing vegetation area (ft <sup>2</sup> )			
<b>Existing Conditions</b>			
Total Project Area <sup>b</sup> (ft <sup>2</sup> )			
Amount of new hard surface (ft <sup>2</sup> )			
Amount of new pollution generating hard surface (PGHS) <sup>c</sup> (ft <sup>2</sup> )			
Amount of replaced hard surface (ft <sup>2</sup> )			
Amount of replaced PGHS <sup>d</sup> (ft <sup>2</sup> )			
Amount of new plus replaced hard surface (ft <sup>2</sup> )			
Amount of new + replaced PGHS (ft <sup>2</sup> )			
Amount of existing hard surfaces converted to vegetation (ft <sup>2</sup> )			
Amount of Land Disturbed (ft <sup>2</sup> )			
Vegetation to Lawn/Landscaped (acres)			
Native Vegetation to Pasture (acres)			
Existing vegetation area to remain (ft <sup>2</sup> )			
Existing hard surface to remain unaltered (ft <sup>2</sup> )			
Value of proposed improvements (\$)			
Assessed Value of Existing Site Improvements(\$)			
Amount to be Graded/Filled (cubic feet)			

a. All terms are defined in the SWMM glossary.

b. The total project area in the existing condition should typically match the total project area in the proposed condition.

c. The “amount of new PGHS” should be part of or all of “amount of new hard surfaces”.

d. The “amount of replaced PGHS” should be part of or all of “amount of replaced hard surfaces”

## Appendix A Stormwater Site Plan Report Short Form

The Stormwater Site Plan Report Short Form may be used for projects that trigger only Minimum Requirements #1-#5. These projects typically fall within or below the following thresholds:

- The project adds or replaces between 2,000 and 5,000 square feet of hard surface.
- The project disturbs between 7,000 square feet and 1 acre of land.

**If the project quantities exceed any of the above thresholds, prepare a formal Stormwater Site Plan Report per Volume 1, Chapter 4 of the City of Tacoma Stormwater Management Manual.** Environmental Services may also require additional information if warranted by project parameters.

### Chapter 1 – Project Overview

Work Order/Building Permit Number(s): \_\_\_\_\_

Associated City of Tacoma Permit Number(s) (e.g. land use permits, work order permits): \_\_\_\_\_

Applicant Name: \_\_\_\_\_

Applicant Address: \_\_\_\_\_

Applicant Phone Number: \_\_\_\_\_

Applicant E-mail: \_\_\_\_\_

Property Owner: \_\_\_\_\_

Property Owner Address: \_\_\_\_\_

Property Owner Phone Number: \_\_\_\_\_

Property Owner E-mail: \_\_\_\_\_

Project Address: \_\_\_\_\_

Parcel Number: \_\_\_\_\_

Size of Parcel (acres or square feet): \_\_\_\_\_

Identify other agency permits required or associated with the subject parcel (e.g. hydraulic permits, Army Corps 404 permits). Provide Permit numbers if available: \_\_\_\_\_

\_\_\_\_\_

Watershed: \_\_\_\_\_

Brief description of the project to include the following:

Current site condition and/or use: \_\_\_\_\_

\_\_\_\_\_

\_\_\_\_\_



Proposed site condition and/or use: \_\_\_\_\_

Have any other site improvements (include all new impervious surfaces and areas cleared) occurred on the site after January 1, 2003? List square footages and description: \_\_\_\_\_

Project impacts. Please fill in the following table (include onsite and offsite):

**Table 1 - 4: Project Threshold Worksheet**

Description <sup>a</sup>	Onsite	Offsite	Total
<b>Existing Conditions</b>			
Total Project Area <sup>b</sup> (ft <sup>2</sup> )			
Existing hard surface (ft <sup>2</sup> )			
Existing vegetation area (ft <sup>2</sup> )			
<b>Existing Conditions</b>			
Total Project Area <sup>b</sup> (ft <sup>2</sup> )			
Amount of new hard surface (ft <sup>2</sup> )			
Amount of new pollution generating hard surface (PGHS) <sup>c</sup> (ft <sup>2</sup> )			
Amount of replaced hard surface (ft <sup>2</sup> )			
Amount of replaced PGHS <sup>d</sup> (ft <sup>2</sup> )			
Amount of new plus replaced hard surface (ft <sup>2</sup> )			
Amount of new + replaced PGHS (ft <sup>2</sup> )			
Amount of existing hard surfaces converted to vegetation (ft <sup>2</sup> )			
Amount of Land Disturbed (ft <sup>2</sup> )			
Vegetation to Lawn/Landscaped (acres)			
Native Vegetation to Pasture (acres)			
Existing hard surface to remain unaltered (ft <sup>2</sup> )			
Existing vegetation area to remain (ft <sup>2</sup> )			

a. All terms are defined in the SWMM glossary.

b. The total project area in the existing condition should typically match the total project area in the proposed condition.

c. The “amount of new PGHS” should be part of or all of “amount of new hard surfaces”.

d. The “amount of replaced PGHS” should be part of or all of “amount of replaced hard surfaces”

## Chapter 2 – Existing Condition Summary

### Existing Site Conditions (Check all that apply)

1. Describe the existing site conditions. (Check all that apply)
  - Forest     Pasture/prairie grass     Pavement     Landscaping     Brush
  - Trees     Other
  
2. Describe how surface water (stormwater) drainage flows across/from the site. (Check all that apply)
  - Sheet Flow     Gutter     Catch Basin     Ditch/Swale     Storm sewer pipes
  - Stream/Creek     Other
  
3. Describe, discuss and identify the following for the project site:
  - a. Topography – is the site:  Flat     Rolling     Steep
  - b. Natural and man-made drainage patterns (which direction does stormwater flow and how): \_\_\_\_\_  
 \_\_\_\_\_  
 \_\_\_\_\_  
 \_\_\_\_\_
  - c. Are there any known historical drainage problems such as flooding, erosion, etc.  
 \_\_\_\_\_  
 \_\_\_\_\_  
 \_\_\_\_\_
  - d. Existing utilities (Check all that are on the site and show on site map with legend)
    - Storm     Water     Sewer     Other \_\_\_\_\_
  - e. Are sensitive and critical areas present on or near the site (i.e. vegetative buffers, wetlands, steep slopes, floodplains, geologic hazard areas, streams, creeks, ponds, ravines, springs, etc.)?
    - Yes (show on site map)                       No
  - f. Are existing fuel tanks present on the site?
    - Yes (show on site map)                       No
  - g. Is this site within the South Tacoma Groundwater Protection District (on GovME or SWMM Volume 1, Chapter 2, Figure 1 - 2)?
    - Yes     No

h. Is the site within the aquifer recharge area (on GovME under Building and Land Use/ Critical Areas)?

- Yes  No

i. Are groundwater wells present onsite and/or within 100 feet of the site?

- Yes (show on site map)  No

j. Are septic systems present onsite and/or within 100 feet of the site?

- Yes (show on site map)  No

k. Are there existing public and/or private easements on the project site?

- Yes (show on site map & provide recording numbers)  No

4. Provide a soils report to identify the following (attach soils report as Appendix to Stormwater Site Plan):

a. Date of soil investigation: \_\_\_\_\_

b. Soil type and/or infiltration rate: \_\_\_\_\_

**NOTE:** See Volume 3, Appendix B to determine when soils report is needed for a project.

c. Groundwater elevation: \_\_\_\_\_

d. Location of test pits (show on site map).

e. Attach the soils report (with soil log) to this document.

**Adjacent Areas**

1. Check any adjacent areas that may be affected by site disturbance and describe in item 2 below (check all that apply):

- Streams\*       Lakes\*       Wetlands\*       Steep Slopes\*
- Residential Areas    Roads       Ditches, pipes, culverts
- Other \_\_\_\_\_

*\* If site is on or adjacent to a critical area, the City of Tacoma may require additional information, engineering, and other permits to be submitted with this short-form.*

2. Describe how and where surface water enters the site from upstream properties:

\_\_\_\_\_

\_\_\_\_\_

\_\_\_\_\_

Describe how and where surface water exits the site:

\_\_\_\_\_

\_\_\_\_\_

---

### Chapter 3 – Offsite Analysis (Qualitative)

1. Describe the downstream drainage path leading from the site to the receiving body of water. (Minimum distance of ¼-mile (1320 feet)) {e.g. water flows from site, into curb-line to catch basin at intersection of X and Y streets. A 12-inch pipe system conveys water another 1000 feet to a ravine/wetland.}

---

---

---

---

---

---

---

---

2. Investigate the drainage system ¼ mile downstream from the project by site visit, including the following items:

- a. Problems reported or observed during the site visit:

---

---

---

- b. Existing/potential constrictions or capacity deficiencies in the drainage system:

---

---

---

- c. Existing/potential flooding problems:

---

---

---

- d. Existing/potential overtopping, scouring, bank sloughing, or sedimentation:

---

---

---

- e. Qualitative data on features such as land use, hard surface, topography, soils, presence of streams, and wetlands:

---



---



---

- f. Information on pipe sizes, channel characteristics and drainage structures:

---



---



---

- g. Date and weather at the time of the inspection (was it raining during site visit?):

---



---



---

**Chapter 4 – Low Impact Development Principles**

Where feasible, sites shall use the following low impact development site design principles.

Check those principles that will be used onsite. The applicant is not required to revise their proposed design in order to accommodate these principles but shall use the principles when feasible.

- Minimization of land disturbance by fitting development to the natural terrain.
- Minimization of land disturbance by confining construction to the smallest area feasible and away from critical areas.
- Preservation of natural vegetation.
- Locating impervious surfaces over less permeable soils.
- Clustering Buildings
- Minimizing Impervious Surfaces

**Chapter 5 – Discussion of Minimum Requirements**

The following elements are required for the Stormwater Site Plan Report. Describe how each of the Minimum Requirements will be satisfied. The applicant can check the boxes that apply or describe the alternate means used to comply with the Minimum Requirements. Review Volume 1 of the SWMM to determine which Minimum Requirements apply to a project.

Minimum Requirement #1 – Preparation of a Stormwater Site Plan

- This stormwater site plan short form report satisfies this requirement.
- Other \_\_\_\_\_

**Minimum Requirement #2 – Construction Stormwater Pollution Prevention**

- The Construction Stormwater Pollution Prevention Plan Short Form and TESC Plan Drawing(s) satisfy this requirement.
- Other: \_\_\_\_\_

**Minimum Requirement #3 – Source Control of Pollution**

- For a single family residence, the homeowner shall comply with all Best Management Practices (as applicable) contained in Volume 4, Chapter 3 of the 2016 City of Tacoma Stormwater Management Manual.
- For commercial or industrial facilities, complete the, “Worksheet for Commercial and Industrial Activities” contained in Volume 3, Chapter 2 of the 2016 City of Tacoma Stormwater Management Manual. Attach the worksheet to the Stormwater Site Plan Report. The owner or operator shall comply with all BMPs checked.
- Other: \_\_\_\_\_

**Minimum Requirement #4 – Preservation of Natural Drainage Systems and Outfalls**

All boxes (except Other) should be checked for this Minimum Requirement.

- The natural drainage patterns have been maintained to the maximum extent feasible.
- Discharges from the project site occur at the natural location to the maximum extent feasible.
- Discharge from the project site will not cause a significant adverse impact to downstream receiving waters and downgradient properties.
- Other: \_\_\_\_\_

**Minimum Requirement #5 – Onsite Stormwater Management**

The following BMPs are proposed for meeting this requirement. See Volume 3 and Volume 6 of the SWMM for feasibility and design requirements for onsite stormwater management techniques. If there are multiple surface types (more than one roof), ensure the means of onsite management is described for each.

**Roofs:**

- Downspout Infiltration Trench
- Downspout Dry Well
- Rain Garden
- Bioretention Facility
- Dispersion Trench
- Splashblocks
- Perforated Stubout
- Collect and Convey

**Other Hard Surfaces:**

- Concentrated Flow Dispersion
- Permeable Pavement
- Rain Garden
- Bioretention Facility
- Sheet Flow Dispersion

- Concentrated Flow Dispersion
- Collect and Convey

Lawn and Landscaped Areas:

- Post Construction Soil Quality and Depth
- Other: \_\_\_\_\_

Minimum Requirement #9 – Operation and Maintenance

- See Chapter 6 of this Stormwater Site Plan Short Form Report.
- Other: \_\_\_\_\_

Maintenance Requirement #10 – Offsite Analysis and Mitigation

- See Chapter 3 of this Stormwater Site Plan Short Form Report.
- Other: \_\_\_\_\_

**NOTE:** *If Minimum Requirements #6, #7, or, #8 apply to a project this short form cannot be used.*

**Chapter 6 – Operation and Maintenance Manual**

1. Describe the onsite storm system. Include each type of facility, including its function and operation. Include any manufacturer’s documentation.

---



---



---



---

2. Indicate the person or organization responsible for maintenance of the onsite storm system, including phone number, address and email.

---



---



---



---

3. Indicate where the Operation and Maintenance manual is to be kept. Note that it must be made available to the City for inspection.

---



---



---



---

4. Attach the maintenance schedules from Volume 1, Appendix C for all facilities used on the site, or create maintenance schedules.

5. Provide a sample maintenance activity log indicating emergency and routine actions to be taken. Attach to this document.
6. Provide an estimated operation and maintenance cost for each component of the proposed system: \_\_\_\_\_

## Chapter 7 – Construction Stormwater Pollution Prevention Plan

The Construction Stormwater Pollution Prevention Plan Short-Form may be used – Please refer to the SWMM Volume 2, Appendix C.

### Drawings Required

- Vicinity Map – GovME map may be used to provide the nearest cross-streets on the site plan with a North arrow.
- Site Map showing new and existing improvements and Grading Plan (this may be on a 8 ½ “ x 11” or 11” x 17” sheet). Include as much detail as possible, including:
  - Elevation contours
  - All existing improvements (including utilities)
  - All proposed improvements
    - Include pipe types and slopes for all proposed stormwater and wastewater lines.
    - Include details for any proposed stormwater system (infiltration trench, rain garden, etc.)
    - If dispersion is proposed show the location of the flowpath and include type of vegetation.
    - Provide a proposed landscape plan.

---

Prepared By:

---

Date Prepared:



**This page intentionally left blank**

## Appendix B Hydraulic Analysis Worksheet

Provide the following information for the project, as applicable.

Permit Number \_\_\_\_\_

Project Name \_\_\_\_\_

Address \_\_\_\_\_

Parcel Number \_\_\_\_\_

### WWHM Model Input

All continuous simulation model files must be provided electronically. Provide separate basin maps for predeveloped or existing conditions and developed conditions. Clearly delineate surface types.

#### *Predeveloped or Existing Basin Conditions (WWHM)*

Basin ID	WWHM Input (ex. C, Forest Flat)	Acreage

#### *Predeveloped or Existing Hydrology (WWHM)*

Basin ID	
Return Interval	Flow (cfs)
2-year	
10-year	
25-year	
100-year	

#### *Developed Basin Conditions (WWHM)*

Basin ID	WWHM Input (ex. C, Forest Flat)	Acreage

**Developed Hydrology (WWHM)**

Basin ID	
Return Interval	Flow (cfs)
2-year	
10-year	
25-year	
100-year	
Water Quality Design Flowrate*	

\* Provide for water quality facilities located upstream of detention.

**SBUH Input**

Provide separate basin maps for predeveloped or existing conditions and developed conditions. Clearly delineate surface types. For the time of concentration, for each sub-basin, provide a figure that shows flowpath used to calculate the time of concentration.

**Predeveloped or Existing Basin Conditions (SBUH)**

Basin ID	Land Use and Cover Condition	Acreage	CN Value	Time of Concentration

**Predeveloped or Existing Site Hydrology (SBUH)**

Basin ID		
Storm Event	Peak Flow (cfs)	Volume (ac-ft)
6-month, 24-hour		
2-year, 24-hour		
10-year, 24-hour		
25-year, 24-hour		
100-year, 24-hour		

**Developed Basin Conditions (SBUH)**

Basin ID	Land Use and Cover Condition	Acreage	CN Value	Time of Concentration

**Developed Site Hydrology (SBUH)**

Basin ID		
Storm Event	Peak Flow (cfs)	Volume (ac-ft)
6-month, 24-hour		
2-year, 24-hour		
10-year, 24-hour		
25-year, 24-hour		
100-year, 24-hour		

**This Page Intentionally Left Blank**

## Appendix C Maintenance Standards for Drainage Facilities

The following pages contain maintenance standards for typical stormwater facilities that may be required for stormwater mitigation. The maintenance standards should be included in the project Operations and Maintenance Manual. If the proposed stormwater system contains facilities or components that are not contained within this Appendix, the applicant is responsible for developing additional maintenance standards and checklists for the proposed facility or component. If there are components listed on the checklists that are not applicable to the proposed design, those components shall be removed. The operation and maintenance checklist shall accurately reflect the proposed design. Stormwater facilities and components should be inspected as specified in the applicable maintenance standards.

The maintenance standards can be used as inspection forms for the system and associated components. Record the date each time an inspection is completed and note any problems and actions taken. Keep completed forms with the Operations and Maintenance Manual. City staff may request to review the maintenance forms as a part of their inspection process. Some components or facilities do not need to be looked at every time an inspection is conducted. Use the suggested frequency at the left of each item as a guideline for activities to be completed with each inspection.

The facility-specific maintenance standards contained in this section are intended to be conditions for determining if maintenance actions are required as identified through inspection. They are not intended to be measures of the facility's required condition at all times between inspections. In other words, exceeding these conditions at any time between inspections and/or maintenance does not automatically constitute a violation of these standards. However, based upon inspection observations, the inspection and maintenance schedules shall be adjusted to minimize the length of time that a facility is in a condition that requires a maintenance action.

The Western Washington Low Impact Development Operation and Maintenance Guidance Document can be used for developing an operation and maintenance manual for stormwater systems that contain low impact development BMPs. The document can be found at: <http://www.ecy.wa.gov/programs/wq/stormwater/municipal/LID/TRAINING/OperationsAndMaintenance.html>.

**NOTE:** Maintenance checklist #29 contains maintenance concerns that may be applicable to any stormwater facility. This checklist must be included in all Operation and Maintenance manuals as applicable.

The City of Tacoma has developed specific template checklists to be used for City maintained facilities. These template checklists shall be used for all City maintained facilities. Do not include the Maintenance Standards contained in Volume C in the Operation and Maintenance Manual - the completed checklist satisfies the maintenance standard requirement.

## Appendix C Contents

#1 - Maintenance Checklist for Detention Ponds	1- 85
#2 - Maintenance Checklist for Infiltration Ponds/Basins	1- 89
#3 - Maintenance Checklist for Infiltration Trenches	1- 93
#4 - Maintenance Checklist for Closed Detention Systems (Tanks/Vaults)	1- 95
#5 - Maintenance Checklist for Control Structure/Flow Restrictor	1- 97
#6 - Maintenance Checklist for Catch Basins/Manholes	1- 99
#7 - Maintenance Checklist for Debris Barriers (e.g., Trash Racks)	1- 102
#8 - Maintenance Checklist for Energy Dissipaters	1- 103
#9 - Maintenance Checklist for Typical Biofiltration Swale	1- 107
#10 - Maintenance Checklist for Wet Biofiltration Swales	1- 110
#11 - Maintenance Checklist for Filter Strips	1- 112
#12 - Maintenance Checklist for Wet Ponds	1- 114
#13 - Maintenance Checklist for Treatment Wetlands	1- 117
#14 - Maintenance Checklist for Wet Vaults	1- 123
#15 - Maintenance Checklist for Sand Filters (above ground/open)	1- 125
#16 - Maintenance Checklist for Sand Filters (below ground/enclosed)	1- 127
#17 - Maintenance Checklist for Baffle Oil/Water Separators - American Petroleum Institute (API) Type	1- 130
#18 - Maintenance Checklist for Coalescing Plate Oil/Water Separators	1- 132
#19 - Maintenance Checklist for Fencing/Shrubbery Screen/Other Landscaping	1- 134
#20 - Maintenance Checklist for Gates	1- 135
#21 - Maintenance Checklist for Grounds (Landscaping)	1- 136
#22 - Maintenance Checklist for Bioretention Facilities	1- 138
#23 - Maintenance Checklist for Rain Gardens	1- 157
#24 - Maintenance Checklist for Cisterns	1- 163
#25 - Maintenance Checklist for Compost Amended Soil	1- 165
#26 - Maintenance Checklist for Vegetated Roof	1- 168
#27 - Maintenance Checklist for Pervious Pavement	1- 174
#28 - Maintenance Checklist for Ballasted Sidewalk	1- 185
#29 - Proprietary Stormwater Devices (Emerging Technologies)	1- 186
#30 - General Maintenance Concerns for Stormwater Facilities	1- 187
#31 - Maintenance Checklist for Trees	1- 189
#32 - Downspout Infiltration Trench or Drywell	1- 190
#33 - Downspout Dispersion	1- 192

**#1 - Maintenance Checklist for Detention Ponds**

Recommended Frequency	Drainage System Feature	Date	Problem	Conditions to Check For	Maintenance Activities and Conditions that Should Exist
Monthly from Oct. – Apr. and after any major storm event (1" in 24 hours)	General		Trash and Debris	Any trash and debris which exceeds 5 cubic feet per 1,000 square feet (this is about equal to the amount of trash it would take to fill up one 32 gallon garbage can). In general, there should be no visual evidence of dumping. If less than threshold, all trash and debris will be removed as part of next scheduled maintenance.	Trash and debris cleared from site.
Annually (preferably Sept.)	General		Poisonous Vegetation and noxious weeds	Any poisonous or nuisance vegetation which may constitute a hazard to maintenance personnel or the public. Any evidence of noxious weeds as defined by State or Local Regulations (Apply requirements of adopted integrated pest management policies for the use of herbicides.)	No danger of poisonous vegetation where maintenance personnel or the public might normally be. Complete eradication of noxious weeds may not be possible. Compliance with state or local eradication policies required. (Coordinate with the Pierce County Noxious Weed Control Board.)
Monthly from Oct. – Apr. and after any major storm event (1" in 24 hours)	General		Contaminants and Pollution	Any evidence of oil, gasoline, contaminants or other pollutants.	No contaminants or pollutants present. (Coordinate removal/cleanup with Environmental Services at 253.502.2222 and/or DOE Spill Response 800.424.8802.)
Monthly from Oct. – Apr.	General		Rodent Holes	If the facility is constructed with a dam or berm, look for rodent holes or any evidence of water piping through the dam or berm.	Rodents removed and dam or berm repaired. (Coordinate with Ecology Dam Safety Office if pond exceeds 10 acre-feet.)



Recommended Frequency	Drainage System Feature	Date	Problem	Conditions to Check For	Maintenance Activities and Conditions that Should Exist
Monthly from Oct. – Apr.	General		Beaver Dams	Beaver dam results in an adverse change in the functioning of the facility.	Facility is returned to design function. (Contact WDFW Region 6 to identify the appropriate Nuisance Wildlife Control Operator)
Annually (preferably Sept.)	General		Insects	When insects such as wasps and hornets interfere with maintenance activities.	Insects destroyed or removed from site in compliance with adopted integrated pest management policies.
Annually (preferably Sept.)	General		Tree Growth and Dense Vegetation	Tree growth and dense vegetation which impedes inspection, maintenance access or interferes with maintenance activity (i.e., slope mowing, silt removal, vactoring, or equipment movements).	Trees and vegetation that do not hinder inspection or maintenance activities. Harvested trees should be recycled into mulch or other beneficial uses.
Annually (preferably Sept.)	General		Hazard Trees	If dead, diseased, or dying trees are identified (Use a certified Arborist to determine health of tree or removal requirements).	Remove hazard trees
Monthly from Oct. – Apr.	Side Slopes of Pond		Erosion	Erosion damage over 2 inches deep where cause of damage is still present or where there is potential for continued erosion.	Slopes should be stabilized using appropriate erosion control measure(s); e.g., rock reinforcement, planting of grass, compaction.
Monthly from Oct. – Apr. and after any major storm event (1" in 24 hours)	Side Slopes of Pond		Erosion	Any erosion observed over 2" deep on a compacted berm embankment.	If erosion is occurring on compacted berms a licensed Civil Engineer should be consulted to resolve source of erosion.

Recommended Frequency	Drainage System Feature	Date	Problem	Conditions to Check For	Maintenance Activities and Conditions that Should Exist
Monthly from Oct. – Apr.	Storage Area		Sediment	Accumulated sediment that exceeds 10 percent of the design pond depth unless otherwise specified or affects inletting or outletting condition of the facility.	Sediment cleaned out to design pond shape and depth; pond reseeded if necessary to control erosion. (If sediment contamination is a potential problem, sediment should be tested regularly to determine leaching potential prior to disposal.)
Monthly from Oct. – Apr.	Storage Area		Liner (If Applicable)	Liner is visible and has more than three 1/4 inch holes in it.	Liner repaired or replaced. Liner is fully covered.
Annually (preferably Sept.)	Pond Berms (Dikes)		Settlement	Any part of berm which has settled 4 inches lower than the design elevation. If settlement is apparent, measure berm to determine amount of settlement. Settling can be an indication of more severe problems with the berm or outlet works. A licensed Civil Engineer should be consulted to determine the source of the settlement.	Dike is restored to the design elevation.
Annually (preferably Sept.)	Pond Berms Over 4 ft in height (Dikes)		Tree Growth	Tree growth on berms over 4 feet in height may lead to piping through the berm which could lead to failure of the berm.	Trees should be removed. If root system is small (base less than 4 inches) the root system may be left in place. Otherwise the roots should be removed and the berm restored. A licensed Civil Engineer should be consulted for proper berm/spillway restoration.

Recommended Frequency	Drainage System Feature	Date	Problem	Conditions to Check For	Maintenance Activities and Conditions that Should Exist
Annually (preferably Sept.)	Pond Berms (Dikes)		Piping	Discernable water flow through pond berm. Ongoing erosion with potential for erosion to continue. (Recommend a Geotechnical Engineer be called in to inspect and evaluate condition and recommend repair.)	Piping eliminated. Erosion potential eliminated.
Annually (preferably Sept.)	Emergency Overflow/ Spillway		Tree Growth	Tree growth on emergency spillways creates blockage problems and may cause failure of the berm due to uncontrolled overtopping.	Trees should be removed. If root system is small (base less than 4 inches) the root system may be left in place. Otherwise the roots should be removed and the berm restored. A licensed Civil Engineer should be consulted for proper berm/spillway restoration.
Annually (preferably Sept.)	Emergency Overflow/ Spillway		Rock Missing	Only one layer of rock exists above native soil in area 5 square feet or larger, or any exposure of native soil at the top of outflow path of spillway. (Riprap on inside slopes need not be replaced.)	Rocks and pad depth are restored to design standards.
Annually (preferably Sept.)	Emergency Overflow/ Spillway		Erosion	Erosion damage over 2 inches deep where cause of damage is still present or where there is potential for continued erosion. Any erosion observed on a compacted berm embankment over 2" deep.	Slopes should be stabilized using appropriate erosion control measure(s); e.g., rock reinforcement, planting of grass, compaction. If erosion is occurring on compacted berms a licensed Civil Engineer should be consulted to resolve source of erosion.

If you are unsure whether a problem exists, please contact Environmental Services at 253.591.5588.

Comments:

**#2 - Maintenance Checklist for Infiltration Ponds/Basins**

Recommended Frequency	Drainage System Feature	Date	Problem	Conditions to Check For	Maintenance Activities and Conditions that Should Exist
Monthly from Oct. – Apr. and after any major storm event (1" in 24 hours)	General		Trash and Debris	Any trash and debris which exceeds 5 cubic feet per 1,000 square feet (this is about equal to the amount of trash it would take to fill up one 32 gallon garbage can). In general, there should be no visual evidence of dumping. If less than threshold all trash and debris will be removed as part of next scheduled maintenance.	Trash and debris cleared from site.
Annually (preferably Sept.)	General		Poisonous Vegetation and noxious weeds	Any poisonous or nuisance vegetation which may constitute a hazard to maintenance personnel or the public. Any evidence of noxious weeds as defined by State or Local Regulations. (Apply requirements of adopted integrated pest management policies for the use of herbicides.)	No danger of poisonous vegetation where maintenance personnel or the public might normally be. (Coordinate with the Pierce County Noxious Weed Control Board) Complete eradication of noxious weeds may not be possible. Compliance with state or local eradication policies required.
Monthly from Oct. – Apr. and after any major storm event (1" in 24 hours)	General		Contaminants and Pollution	Any evidence of oil, gasoline, contaminants or other pollutants.	No contaminants or pollutants present. (Coordinate removal/cleanup with Environmental Services at 253.502.2222 and/or DOE Spill Response 800.424.8802.)
Monthly from Oct. – Apr.	General		Rodent Holes	If the facility is constructed with a dam or berm, look for rodent holes or any evidence of water piping through the dam or berm.	Rodents removed and dam or berm repaired. (Coordinate with Ecology Dam Safety Office if pond exceeds 10 acre-feet.)
Monthly from Oct. – Apr.	General		Beaver Dams	Beaver dam results in an adverse change in the functioning of the facility.	Facility is returned to design function. (Contact WDFW to identify the appropriate Nuisance Wildlife Control Operator)

Recommended Frequency	Drainage System Feature	Date	Problem	Conditions to Check For	Maintenance Activities and Conditions that Should Exist
Annually (preferably Sept.)	General		Insects	When insects such as wasps and hornets interfere with maintenance activities.	Insects destroyed or removed from site. Apply insecticides in compliance with adopted integrated pest management policies.
Monthly from Oct. – Apr.	Storage Area		Water Not Infiltrating	Water ponding in infiltration pond after rainfall ceases and appropriate time allowed for infiltration (24 hours or design infiltration time). (A percolation test pit or test of facility indicates facility is only working at 90 percent of its designed capabilities. If 2 inches or more sediment is present, remove).	Sediment is removed and/or facility is cleaned so that infiltration system works according to design.
Monthly from Oct. – Apr. and after any major storm event (1" in 24 hours)	Rock Filters		Sediment and Debris	By visual inspection, little or no water flows through filter during heavy rain storms.	Gravel in rock filter is replaced.
Monthly from Oct. – Apr.	Ponds		Vegetation	Exceeds 18 inches.	Mow or remove vegetation as necessary. Remove all clippings.
Monthly from Oct. – Apr.	Ponds		Vegetation	Bare spots.	Revegetate and stabilize immediately. Do not apply fertilizers.
Monthly from Oct. – Apr.	Side Slopes of Pond		Erosion	Erosion damage over 2 inches deep where cause of damage is still present or where there is potential for continued erosion.	Slopes should be stabilized using appropriate erosion control measure(s); e.g., rock reinforcement, planting of grass, compaction.

Recommended Frequency	Drainage System Feature	Date	Problem	Conditions to Check For	Maintenance Activities and Conditions that Should Exist
Annually (preferably Sept.)	Pond Berms (Dikes)		Settlements	Any part of berm which has settled 4 inches lower than the design elevation. If settlement is apparent, measure berm to determine amount of settlement. Settling can be an indication of more severe problems with the berm or piping. A licensed Civil Engineer should be consulted to determine the source of the settlement.	Dike is built back to the design elevation.
Annually (preferably Sept.)	Pond Berms (Dikes)		Piping	Discernable water flow through pond berm. Ongoing erosion with potential for erosion to continue. (Recommend a Geotechnical Engineer be called in to inspect and evaluate condition and recommend repair.)	Piping eliminated. Erosion potential eliminated.
Annually (preferably Sept.)	General		Hazard Trees	If dead, diseased, or dying trees are identified (Use a certified Arborist to determine health of tree or removal requirements)	Remove hazard trees
Annually (preferably Sept.)	General		Tree Growth and Dense Vegetation	Tree growth and dense vegetation which impedes inspection, maintenance access or interferes with maintenance activity (i.e., slope mowing, silt removal, vactoring, or equipment movements).	Trees and vegetation that do not hinder inspection or maintenance activities. Harvested trees should be recycled into mulch or other beneficial uses.
Annually (preferably Sept.)	Pond Berms (Dikes)		Tree Growth	Tree growth on berms over 4 feet in height may lead to piping through the berm which could lead to failure of the berm.	Trees should be removed. If root system is small (base less than 4 inches) the root system may be left in place. Otherwise the roots should be removed and the berm restored. A licensed Civil Engineer should be consulted for proper berm/spillway restoration.

Recommended Frequency	Drainage System Feature	Date	Problem	Conditions to Check For	Maintenance Activities and Conditions that Should Exist
Annually (preferably Sept.)	Emergency Overflow/ Spillway		Tree Growth	Tree growth on emergency spillways creates blockage problems and may cause failure of the berm due to uncontrolled overtopping.	Trees should be removed. If root system is small (base less than 4 inches) the root system may be left in place. Otherwise the roots should be removed and the berm restored. A licensed Civil Engineer should be consulted for proper berm/spillway restoration.
Annually (preferably Sept.)	Emergency Overflow/ Spillway		Rock Missing	Only one layer of rock exists above native soil in area 5 square feet or larger, or any exposure of native soil at the top of out flowpath of spillway. (Riprap on inside slopes need not be replaced.)	Rocks and pad depth are restored to design standards.
Annually (preferably Sept.)	Emergency Overflow/ Spillway		Erosion	Erosion damage over 2 inches deep where cause of damage is still present or where there is potential for continued erosion. Any erosion observed on a compacted berm embankment.	Slopes should be stabilized using appropriate erosion control measure(s); e.g., rock reinforcement, planting of grass, compaction. If erosion is occurring on compacted berms a licensed Civil Engineer should be consulted to resolve source of erosion.

If you are unsure whether a problem exists, please contact Environmental Services at 253.591.5588.

Comments:

**#3 - Maintenance Checklist for Infiltration Trenches**

Recommended Frequency	Drainage System Feature	Date	Problem	Conditions to Check For	Maintenance Activities and Conditions that Should Exist
Monthly from Oct. – Apr. and after any major storm event (1" in 24 hours)	General		Trash and Debris	Trash and debris in presettling basin, sump, or observation well/port.	Trash and debris cleared from site.
Annually (preferably Sept.)	General		Poisonous Vegetation and noxious weeds	Any poisonous or nuisance vegetation which may constitute a hazard to maintenance personnel or the public. Any evidence of noxious weeds as defined by State or Local Regulations. (Apply requirements of adopted integrated pest management policies for the use of herbicides.)	No danger of poisonous vegetation where maintenance personnel or the public might normally be. (Coordinate with the Pierce County Noxious Weed Control Board) Complete eradication of noxious weeds may not be possible. Compliance with state or local eradication policies required.
Monthly from Oct. – Apr. and after any major storm event (1" in 24 hours)	General		Contaminants and Pollution	Any evidence of oil, gasoline, contaminants or other pollutants	No contaminants or pollutants present. (Coordinate removal/cleanup with Environmental Services at 253.502.2222 and/or DOE Spill Response 800.424.8802.)
Annually (preferably Sept.)	General		Insects	When insects such as wasps and hornets interfere with maintenance activities.	Insects destroyed or removed from site. Apply insecticides in compliance with adopted integrated pest management policies.
Monthly from Oct. – Apr.	General		Water Not Infiltrating	Water ponding on surface or visible in observation well 24 hours after storm event.	Sediment is removed and/or facility is cleaned so that infiltration system works according to design. Remove any sediment from surface inlet if applicable.



Recommended Frequency	Drainage System Feature	Date	Problem	Conditions to Check For	Maintenance Activities and Conditions that Should Exist
Annually (preferably Sept.) and after any major storm event (1" in 24 hours)	Trenches		Observation Well (Use surface of trench if well is not present)	Water ponds at surface during storm events. Water visible in observation well 48 hours after storm event.	Remove and Replace rock layer and geomembrane or clean rock and geomembrane. Check underdrain pipe for sediment accumulation and remove sediment.
Annually (preferably Sept.)	General		Tree Growth and Dense Vegetation	Tree growth and dense vegetation which impedes inspection, maintenance access or interferes with maintenance activity (i.e., slope mowing, silt removal, vactoring, or equipment movements).	Trees and vegetation that do not hinder inspection or maintenance activities. Harvested trees should be recycled into mulch or other beneficial uses.
Annually (preferably Sept.)	Emergency Overflow/ Spillway		Erosion	Erosion damage over 2 inches deep where cause of damage is still present or where there is potential for continued erosion. Any erosion observed on a compacted berm embankment.	Slopes should be stabilized using appropriate erosion control measure(s); e.g., rock reinforcement, planting of grass, compaction. If erosion is occurring on compacted berms a licensed Civil Engineer should be consulted to resolve source of erosion.
Monthly from Oct. – Apr.	Presettling Sump		Facility or sump filled with sediment and/or debris	6 inches or designed sediment trap depth of sediment.	Sediment is removed.

If you are unsure whether a problem exists, please contact Environmental Services at 253.591.5588.

Comments:

**#4 - Maintenance Checklist for Closed Detention Systems (Tanks/Vaults)**

Recommended Frequency	Drainage System Feature	Date	Problem	Conditions to Check For	Maintenance Activities and Conditions that Should Exist
Monthly from Oct. – Apr. and after any major storm event (1" in 24 hours)	Storage Area		Plugged Air Vents	One-half of the cross-section of a vent is blocked at any point or the vent is damaged.	Vents open and functioning.
Monthly from Oct. – Apr. and after any major storm event (1" in 24 hours)	Storage Area		Debris and Sediment	Accumulated sediment depth exceeds 10 percent of the diameter of the storage area for one-half length of storage vault or any point depth exceeds 15 percent of diameter. (Example: 72-inch storage tank would require cleaning when sediment reaches depth of 7 inches for more than one-half length of tank.)	All sediment and debris removed from storage area.
Annually (preferably Sept.)	Storage Area		Joints Between Tank/Pipe Section	Any openings or voids allowing material to be transported into facility. (Will require engineering analysis to determine structural stability.)	All joints between tank/pipe sections are sealed.
Annually (preferably Sept.)	Storage Area		Tank/Pipe Bent Out of Shape	Any part of tank/pipe is bent out of shape more than 10 percent of its design shape. (Will require engineering analysis to determine structural stability.)	Tank/pipe repaired or replaced to design.
Annually (preferably Sept.)	Storage Area		Vault Structure Includes Cracks in Wall, Bottom, Damage to Frame and/or Top Slab	Cracks wider than one-half inch and any evidence of soil particles entering the structure through the cracks, or maintenance/inspection personnel determines that the vault is not structurally sound.	Vault replaced or repaired to design specifications and is structurally sound.
Annually (preferably Sept.)	Storage Area		Vault Structure Includes Cracks in Wall, Bottom, Damage to Frame and/or Top Slab	Cracks wider than one-half inch at the joint of any inlet/outlet pipe or any evidence of soil particles entering the vault through the walls.	No cracks more than one-fourth inch wide at the joint of the inlet/outlet pipe.

Recommended Frequency	Drainage System Feature	Date	Problem	Conditions to Check For	Maintenance Activities and Conditions that Should Exist
Annually (preferably Sept.)	Manhole		Cover Not in Place	Cover is missing or only partially in place. Any open manhole requires maintenance.	Manhole cover is in place.
Annually (preferably Sept.)	Manhole		Locking Mechanism Not Working	Mechanism cannot be opened by one maintenance person with proper tools. Bolts into frame have less than one-half inch of thread (may not apply to self-locking lids).	Mechanism opens with proper tools.
Annually (preferably Sept.)	Manhole		Cover Difficult to Remove	One maintenance person cannot remove lid after applying normal lifting pressure. Intent is to keep cover from sealing off access to maintenance.	Cover can be removed and reinstalled by one maintenance person.
Annually (preferably Sept.)	Manhole		Ladder Rungs Unsafe	Ladder is unsafe due to missing rungs, misalignment, not securely attached to structure wall, rust, or cracks.	Ladder meets design standards. Allows maintenance person safe access.
Annually (preferably Sept.)	General		Insects	When insects such as wasps and hornets interfere with maintenance activities.	Insects destroyed or removed from site. Apply insecticides in compliance with adopted integrated pest management policies.

If you are unsure whether a problem exists, please contact Environmental Services at 253.591.5588.

Tanks and vaults are a confined space. Visual inspections should be performed aboveground. If entry is required it should be performed by qualified personnel.

Comments:

**#5 - Maintenance Checklist for Control Structure/Flow Restrictor**

Recommended Frequency	Drainage System Feature	Date	Problem	Conditions to Check For	Maintenance Activities and Conditions that Should Exist
Monthly from Oct. – Apr. and after any major storm event (1" in 24 hours)	General		Trash and Debris (Includes Sediment)	Material exceeds 25 percent of sump depth or 1 foot below orifice plate.	Control structure orifice is not blocked. All trash and debris removed.
Annually (preferably Sept.)	General		Structural Damage	Structure is not securely attached to manhole wall.	Structure securely attached to wall and outlet pipe.
Annually (preferably Sept.)	General		Structural Damage	Structure is not in upright position (allow up to 10 percent from plumb).	Structure in correct position.
Annually (preferably Sept.)	General		Structural Damage	Connections to outlet pipe are not watertight and show signs of rust.	Connections to outlet pipe are watertight; structure repaired or replaced and works as designed.
Annually (preferably Sept.)	General		Structural Damage	Any holes—other than designed holes—in the structure.	Structure has no holes other than designed holes.
Annually (preferably Sept.)	Cleanout Gate		Damaged or Missing	Cleanout gate is not watertight or is missing.	Gate is watertight and works as designed.
Annually (preferably Sept.)	Cleanout Gate		Damaged or Missing	Gate cannot be moved up and down by one maintenance person.	Gate moves up and down easily and is watertight.
Annually (preferably Sept.)	Cleanout Gate		Damaged or Missing	Chain/rod leading to gate is missing or damaged.	Chain is in place and works as designed.
Annually (preferably Sept.)	Cleanout Gate		Damaged or Missing	Gate is rusted over 50 percent of its surface area.	Gate is repaired or replaced to meet design standards.
Annually (preferably Sept.)	Orifice Plate		Damaged or Missing	Control device is not working properly due to missing, out of place, or bent orifice plate.	Plate is in place and works as designed.
Monthly from Oct. – Apr. and after any major storm event (1" in 24 hours)	Orifice Plate		Obstructions	Any trash, debris, sediment, or vegetation blocking the plate.	Plate is free of all obstructions and works as designed.
Monthly from Oct. – Apr. and after any major storm event (1" in 24 hours)	Overflow Pipe		Obstructions	Any trash or debris blocking (or having the potential of blocking) the overflow pipe.	Pipe is free of all obstructions and works as designed.

Recommended Frequency	Drainage System Feature	Date	Problem	Conditions to Check For	Maintenance Activities and Conditions that Should Exist
Annually (preferably Sept.)	Manhole		Cover Not in Place	Cover is missing or only partially in place. Any open manhole requires maintenance.	Manhole is closed.
Annually (preferably Sept.)	Manhole		Locking Mechanism Not Working	Mechanism cannot be opened by one maintenance person with proper tools. Bolts into frame have less than one-half inch of thread (may not apply to self-locking lids).	Mechanism opens with proper tools.
Annually (preferably Sept.)	Manhole		Cover Difficult to Remove	One maintenance person cannot remove lid after applying normal lifting pressure. Intent is to keep cover from sealing off access to maintenance.	Cover can be removed and reinstalled by one maintenance person.
Annually (preferably Sept.)	Manhole		Ladder Rungs Unsafe	Ladder is unsafe due to missing rungs, misalignment, not securely attached to structure wall, rust, or cracks.	Ladder meets design standards. Allows maintenance person safe access.
Annually (preferably Sept.)	General		Insects	When insects such as wasps and hornets interfere with maintenance activities.	Insects destroyed or removed from site. Apply insecticides in compliance with adopted integrated pest management policies.

If you are unsure whether a problem exists, please contact Environmental Services at 253.591.5588.

Control structures are usually considered a confined space. Visual inspections should be performed aboveground. If entry is required it should be performed by qualified personnel.

Comments:

**#6 - Maintenance Checklist for Catch Basins/Manholes**

Recommended Frequency	Drainage System Feature	Date	Problem	Conditions to Check For	Maintenance Activities and Conditions that Should Exist
Annually (preferably Sept.)	General		"Dump no pollutants" Stencil or stamp not visible	Stencil or stamp should be visible and easily read	Warning signs (e.g., "Dump No Waste-Drains to Stream") shall be painted or embossed on or adjacent to all storm drain inlets.
Monthly from Oct. – Apr. and after any major storm event (1" in 24 hours)	General		Trash and Debris	Trash or debris which is located immediately in front of the catch basin opening or is blocking inlet capacity of the basin by more than 10 percent.	No trash or debris located immediately in front of catch basin or on grate opening.
Monthly from Oct. – Apr. and after any major storm event (1" in 24 hours)	General		Trash and Debris	Trash or debris (in the basin) that exceeds 60 percent of the sump depth as measured from the bottom of basin to invert of the lowest pipe into or out of the basin, but in no case less than a minimum of 6 inches clearance from the debris surface to the invert of the lowest pipe.	No trash or debris in the catch basin.
Monthly from Oct. – Apr. and after any major storm event (1" in 24 hours)	General		Trash and Debris	Trash or debris in any inlet or outlet pipe blocking more than one-third of its height.	Inlet and outlet pipes free of trash or debris.
Monthly from Oct. – Apr. and after any major storm event (1" in 24 hours)	General		Trash and Debris	Dead animals or vegetation that could generate odors and cause complaints or dangerous gases (e.g., methane).	No dead animals or vegetation present within the catch basin.
Monthly from Oct. – Apr. and after any major storm event (1" in 24 hours)	General		Sediment	Sediment (in the basin) that exceeds 60 percent of the sump depth as measured from the bottom of basin to invert of the lowest pipe into or out of the basin, but in no case less than a minimum of 6 inches clearance from the sediment surface to the invert of the lowest pipe.	No sediment in the catch basin.

Recommended Frequency	Drainage System Feature	Date	Problem	Conditions to Check For	Maintenance Activities and Conditions that Should Exist
Annually (preferably Sept.)	General		Structure Damage to Frame and/or Top Slab	Top slab has holes larger than 2 square inches or cracks wider than one-fourth inch (intent is to make sure no material is running into basin).	Top slab is free of holes and cracks.
Annually (preferably Sept.)	General		Structure Damage to Frame and/or Top Slab	Frame not sitting flush on top slab, i.e., separation of more than three-fourth inch of the frame from the top slab. Frame not securely attached.	Frame is sitting flush on the riser rings or top slab and firmly attached.
Annually (preferably Sept.)	General		Fractures or Cracks in Basin Walls/ Bottom	Maintenance person judges that structure is unsound.	Basin replaced or repaired to design standards.
Annually (preferably Sept.)	General		Fractures or Cracks in Basin Walls/ Bottom	Grout fillet has separated or cracked wider than one-half-inch and longer than 1 foot at the joint of any inlet/outlet pipe or any evidence of soil particles entering catch basin through cracks.	Pipe is regouted and secure at basin wall.
Annually (preferably Sept.)	General		Settlement/ Misalignment	If failure of basin has created a safety, function, or design problem.	Basin replaced or repaired to design standards.
Monthly from Oct. – Apr. and after any major storm event (1" in 24 hours)	General		Vegetation	Vegetation growing across and blocking more than 10 percent of the basin opening.	No vegetation blocking opening to basin.
Monthly from Oct. – Apr. and after any major storm event (1" in 24 hours)	General		Vegetation	Vegetation growing in inlet/outlet pipe joints that is more than 6 inches tall and less than 6 inches apart.	No vegetation or root growth present.
Monthly from Oct. – Apr. and after any major storm event (1" in 24 hours)	General		Contamination and Pollution	Any evidence of oil, gasoline, contaminants or other pollutants.	No contaminants or pollutants present. (Coordinate removal/cleanup with Environmental Services at 253.502.2222 and/or DOE Spill Response 800.424.8802.)

Recommended Frequency	Drainage System Feature	Date	Problem	Conditions to Check For	Maintenance Activities and Conditions that Should Exist
Annually (preferably Sept.)	Catch Basin Cover		Cover Not in Place	Cover is missing or only partially in place.	Any open catch basin requires maintenance. Catch basin cover is in place.
Annually (preferably Sept.)	Catch Basin Cover		Locking Mechanism Not Working	Mechanism cannot be opened by one maintenance person with proper tools. Bolts into frame have less than one-half-inch of thread.	Mechanism opens with proper tools.
Annually (preferably Sept.)	Catch Basin Cover		Cover Difficult to Remove	One maintenance person cannot remove lid after applying normal lifting pressure. (Intent is keep cover from sealing off access to maintenance.)	Cover can be removed by one maintenance person.
Annually (preferably Sept.)	Ladder		Ladder Rungs Unsafe	Ladder is unsafe due to missing rungs, not securely attached to basin wall, misalignment, rust, cracks, or sharp edges.	Ladder meets design standards and allows maintenance person safe access.
Annually (preferably Sept.)	Grates		Grate opening Unsafe	Grate with opening wider than seven-eighths of an inch.	Grate opening meets design standards.
Monthly from Oct. – Apr. and after any major storm event (1" in 24 hours)	Grates		Trash and Debris	Trash and debris that is blocking more than 20 percent of grate surface inletting capacity.	Grate free of trash and debris.
Annually (preferably Sept.)	Grates		Damaged or Missing.	Grate missing or broken member(s) of the grate.	Grate is in place and meets design standards.
Annually (preferably Sept.)	General		Insects	When insects such as wasps and hornets interfere with maintenance activities.	Insects destroyed or removed from site. Apply insecticides in compliance with adopted integrated pest management policies.

If you are unsure whether a problem exists, please contact Environmental Services at 253.591.5588.

Comments:



**#7 - Maintenance Checklist for Debris Barriers (e.g., Trash Racks)**

Recommended Frequency	Drainage System Feature	Date	Problem	Conditions to Check For	Maintenance Activities and Conditions that Should Exist
Monthly from Oct. – Apr. and after any major storm event (1” in 24 hours)	General		Trash and Debris	Trash or debris that is plugging more than 20 percent of the openings in the barrier.	Barrier cleared to design flow capacity.
Annually (preferably Sept.)	General		Damaged/ Missing Bars.	Bars are bent out of shape more than 3 inches.	Bars in place with no bends more than three-fourth inch.
Annually (preferably Sept.)	General		Damaged/ Missing Bars.	Bars are missing or entire barrier missing.	Bars in place according to design.
Annually (preferably Sept.)	General		Damaged/ Missing Bars.	Bars are loose and rust is causing 50 percent deterioration to any part of barrier.	Barrier replaced or repaired to design standards.
Annually (preferably Sept.)	General		Inlet/Outlet Pipe	Debris barrier missing or not attached to pipe.	Barrier firmly attached to pipe.
Annually (preferably Sept.)	General		Insects	When insects such as wasps and hornets interfere with maintenance activities.	Insects destroyed or removed from site. Apply insecticides in compliance with adopted integrated pest management policies.

If you are unsure whether a problem exists, please contact Environmental Services at 253.591.5588.

Comments:

**#8 - Maintenance Checklist for Energy Dissipaters**

Recommended Frequency	Drainage System Feature	Date	Problem	Conditions to Check For	Maintenance Activities and Conditions that Should Exist
External:					
Monthly from Oct. – Apr. and after any major storm event (1” in 24 hours)	Rock Pad		Erosion	Soil erosion in or adjacent to rock pad.	Rock pad replaced to design standards.
Monthly from Oct. – Apr. and after any major storm event (1” in 24 hours)	Dispersion Trench		Pipe Plugged with Sediment	Accumulated sediment that exceeds 20 percent of the design depth.	Pipe cleaned/flushed so that it matches design.
Monthly from Oct. – Apr. and after any major storm event (1” in 24 hours)	Dispersion Trench		Not Discharging Water Properly	Visual evidence of water discharging at concentrated points along trench (normal condition is a “sheet flow” of water along trench). Intent is to prevent erosion damage.	Trench redesigned or rebuilt to standards.
Monthly from Oct. – Apr. and after any major storm event (1” in 24 hours)	Dispersion Trench		Perforations Plugged	Over 1/2 of perforations in pipe are plugged with debris and sediment.	Perforated pipe cleaned or replaced.
Monthly from Oct. – Apr. and after any major storm event (1” in 24 hours)	Dispersion Trench		Water Flows Out Top of “Distributor” Catch Basin.	Maintenance person observes or receives credible report of water flowing out during any storm less than the design storm or the trench is causing or appears likely to cause damage.	Facility rebuilt or redesigned to standards.
Monthly from Oct. – Apr. and after any major storm event (1” in 24 hours)	Dispersion Trench		Receiving Area Over-Saturated	Water in receiving area is causing or has potential to cause landslide problems.	No danger of landslides.
Spring and Summer	Flowpath		No or minimal vegetation	Vegetation removed or dead. Vegetation replaced by hard surface.	Design vegetated flowpath is restored.

Recommended Frequency	Drainage System Feature	Date	Problem	Conditions to Check For	Maintenance Activities and Conditions that Should Exist
Internal:					
Monthly from Oct. – Apr. and after any major storm event (1” in 24 hours)	Manhole/ Chamber		Worn or Damaged Post, Baffles, Side of Chamber	Structure dissipating flow deteriorates to one-half of original size or any concentrated worn spot exceeding 1 square foot which would make structure unsound	Structure replaced to design standards.
Monthly from Oct. – Apr. and after any major storm event (1” in 24 hours)	Manhole/ Chamber		Trash and Debris	Trash or debris (in the basin) that exceeds 60 percent of the sump depth as measured from the bottom of basin to invert of the lowest pipe into or out of the basin, but in no case less than a minimum of 6 inches clearance from the debris surface to the invert of the lowest pipe.	No trash or debris in the catch basin.
Monthly from Oct. – Apr. and after any major storm event (1” in 24 hours)	Manhole/ Chamber		Trash and Debris	Trash or debris in any inlet or outlet pipe blocking more than one-third of its height.	Inlet and outlet pipes free of trash or debris.
Monthly from Oct. – Apr. and after any major storm event (1” in 24 hours)	Manhole/ Chamber		Trash and Debris	Dead animals, trash or vegetation that could generate odors that could cause complaints or dangerous gases (e.g., methane).	No dead animals, trash or vegetation present within the catch basin.
Monthly from Oct. – Apr. and after any major storm event (1” in 24 hours)	Manhole/ Chamber		Sediment	Sediment (in the basin) that exceeds 60 percent of the sump depth as measured from the bottom of basin to invert of the lowest pipe into or out of the basin, but in no case less than a minimum of 6 inches clearance from the sediment surface to the invert of the lowest pipe.	No sediment in the catch basin.
Annually (preferably Sept.)	Manhole/ Chamber		Structure Damage to Frame and/or Top Slab	Top slab has holes larger than 2 square inches or cracks wider than one-fourth inch (intent is to make sure no material is running into basin).	Top slab is free of holes and cracks.

Recommended Frequency	Drainage System Feature	Date	Problem	Conditions to Check For	Maintenance Activities and Conditions that Should Exist
Annually (preferably Sept.)	Manhole/ Chamber		Structure Damage to Frame and/or Top Slab	Frame not sitting flush on top slab, i.e., separation of more than three-fourth inch of the frame from the top slab. Frame not securely attached.	Frame is sitting flush on the riser rings or top slab and firmly attached.
Annually (preferably Sept.)	Manhole/ Chamber		Fractures or Cracks in Basin Walls/ Bottom	Maintenance person judges that structure is unsound.	Basin replaced or repaired to design standards.
Annually (preferably Sept.)	Manhole/ Chamber		Fractures or Cracks in Basin Walls/ Bottom	Grout fillet has separated or cracked wider than one-half-inch and longer than 1 foot at the joint of any inlet/outlet pipe or any evidence of soil particles entering catch basin through cracks.	Pipe is regouted and secure at basin wall.
Annually (preferably Sept.)	Manhole/ Chamber		Settlement/ Misalignment	If failure of basin has created a safety, function, or design problem.	Basin replaced or repaired to design standards.
Monthly from Oct. – Apr. and after any major storm event (1" in 24 hours)	Manhole/ Chamber		Contamination and Pollution	Any evidence of oil, gasoline, contaminants or other pollutants.	No contaminants or pollutants present. (Coordinate removal/ cleanup with Environmental Services at 253.502.2222 and/or DOE Spill Response 800-424-8802.)
Annually (preferably Sept.)	Catch Basin/ Manhole Cover		Cover Not in Place	Cover is missing or only partially in place.	Any open catch basin/ manhole requires maintenance. Catch basin cover is closed.
Annually (preferably Sept.)	Catch Basin/ Manhole Cover		Locking Mechanism Not Working	Mechanism cannot be opened by one maintenance person with proper tools. Bolts into frame have less than one-half-inch of thread.	Mechanism opens with proper tools.
Annually (preferably Sept.)	Catch Basin/ Manhole Cover		Cover Difficult to Remove	One maintenance person cannot remove lid after applying normal lifting pressure. (Intent is keep cover from sealing off access to maintenance.)	Cover can be removed by one maintenance person.

Recommended Frequency	Drainage System Feature	Date	Problem	Conditions to Check For	Maintenance Activities and Conditions that Should Exist
Annually (preferably Sept.)	General		Insects	When insects such as wasps and hornets interfere with maintenance activities.	Insects destroyed or removed from site. Apply insecticides in compliance with adopted integrated pest management policies.

If you are unsure whether a problem exists, please contact Environmental Services at 253.591.5588.

Comments:

**#9 - Maintenance Checklist for Typical Biofiltration Swale**

Recommended Frequency	Drainage System Feature	Date	Problem	Conditions to Check For	Maintenance Activities and Conditions that Should Exist
Monthly from Oct. – Apr. and after any major storm event (1" in 24 hours)	General		Sediment Accumulation on Grass	Sediment depth exceeds 2 inches or inhibits vegetation growth in 10 percent or more of swale.	Remove sediment deposits on grass treatment area of the bioswale. When finished, swale should be level from side to side and drain freely toward outlet.  There should be no areas of standing water once inflow has ceased.
Monthly from Oct. – Apr. and after any major storm event (1" in 24 hours)	General		Standing Water	Water stands in the swale between storms and does not drain freely.	Any of the following may apply: remove sediment or trash blockages, improve grade from head to foot of swale, remove clogged check dams, add underdrains or convert to a wet biofiltration swale. Consult the design engineer if underdrains are proposed to be removed or conversion is proposed.
Monthly from Oct. – Apr. and after any major storm event (1" in 24 hours)	General		Flow spreader	Flow spreader uneven or clogged so that flows are not uniformly distributed through entire swale width.	Level the spreader and clean so that flows are spread evenly over entire swale width.
Monthly from Oct. – Apr. and after any major storm event (1" in 24 hours)	General		Constant Baseflow	When small quantities of water continually flow through the swale, even when it has been dry for weeks, and an eroded, muddy channel has formed in the swale bottom.	Add a low-flow pea-gravel drain the length of the swale or by-pass the baseflow around the swale.
Monthly from Oct. – Apr. and after any major storm event (1" in 24 hours)	General		Poor Vegetation Coverage	When grass is sparse or bare or eroded patches occur in more than 10 percent of the swale bottom.	Determine why grass growth is poor and correct that condition. Re-plant with plugs of grass from the upper slope: plant in the swale bottom at 8-inch intervals or re-seed into loosened, fertile soil.

Recommended Frequency	Drainage System Feature	Date	Problem	Conditions to Check For	Maintenance Activities and Conditions that Should Exist
Monthly from Oct. – Apr. and after any major storm event (1” in 24 hours)	General		Vegetation	When the grass becomes excessively tall (greater than 10 inches); when nuisance weeds and other vegetation start to take over.	Mow vegetation or remove nuisance vegetation so that flow is not impeded. Grass should be mowed to a height of 3 to 8 inches, but not below design flow level. Remove grass clippings.
Monthly from Oct. – Apr. and after any major storm event (1” in 24 hours)	General		Excessive Shading	Grass growth is poor because sunlight does not reach swale.	If possible, trim back over-hanging limbs and remove brushy vegetation on adjacent slopes.
Monthly from Oct. – Apr. and after any major storm event (1” in 24 hours)	General		Inlet/Outlet/Underdrain	Inlet/outlet areas clogged with sediment and/or debris.	Remove material so that there is no clogging or blockage in the inlet and outlet area.  If underdrain, avoid vehicular traffic on swale bottom.
Monthly from Oct. – Apr. and after any major storm event (1” in 24 hours)	General		Trash and Debris Accumulation	Trash and debris accumulated in the bioswale.	Remove leaves, litter, and oily materials, and re-seed or resod, and regrade, as needed. Clean curb cuts and level spreaders as needed.
Monthly from Oct. – Apr. and after any major storm event (1” in 24 hours)	General		Erosion/Scouring	Eroded or scoured swale bottom due to flow channelization, or higher flows.	For ruts or bare areas less than 12 inches wide, repair the damaged area by filling with crushed gravel. If bare areas are large, generally greater than 12 inches wide, the swale should be re-graded and re-seeded. For smaller bare areas, overseed when bare spots are evident, or take plugs of grass from the upper slope and plant in the swale bottom at 8-inch intervals.

Recommended Frequency	Drainage System Feature	Date	Problem	Conditions to Check For	Maintenance Activities and Conditions that Should Exist
Annually (preferably Sept.)	General		Insects	When insects such as wasps and hornets interfere with maintenance activities.	Insects destroyed or removed from site. Apply insecticides in compliance with adopted integrated pest management policies.

If you are unsure whether a problem exists, please contact Environmental Services at 253.591.5588.

Comments:



**#10 - Maintenance Checklist for Wet Biofiltration Swales**

Recommended Frequency	Drainage System Feature	Date	Problem	Conditions to Check For	Maintenance Activities and Conditions that Should Exist
Monthly from Oct. – Apr. and after any major storm event (1" in 24 hours)	General		Sediment Accumulation	Sediment depth exceeds 2 inches in 10 percent of the swale treatment area.	Remove sediment deposits in treatment area.
Monthly from Oct. – Apr. and after any major storm event (1" in 24 hours)	General		Water Depth	Water not retained to a depth of about 4 inches during the wet season.	Build up or repair outlet berm so that water is retained in the wet swale.
Monthly from Oct. – Apr. and after any major storm event (1" in 24 hours)	General		Wetland Vegetation	Vegetation becomes sparse and does not provide adequate filtration, OR vegetation is crowded out by very dense clumps of cattail, which do not allow water to flow through the clumps.	Determine cause of lack of vigor of vegetation and correct. Replant as needed. For excessive cattail growth, cut cattail shoots back and compost offsite. Dig out roots as necessary. Note: Normally wetland vegetation does not need to be harvested unless die-back is causing oxygen depletion in downstream waters. Fall harvesting of Juncus species is not recommended.
Monthly from Oct. – Apr. and after any major storm event (1" in 24 hours)	General		Inlet/Outlet	Inlet/outlet area clogged with sediment and/or debris.	Remove clogging or blockage in the inlet and outlet areas.
Monthly from Oct. – Apr. and after any major storm event (1" in 24 hours)	General		Trash and Debris Accumulation	Any trash and debris which exceeds 5 cubic feet per 1,000 square feet (this is about equal to the amount of trash it would take to fill up one 32 gallon garbage can). In general, there should be no visual evidence of dumping. If less than threshold all trash and debris will be removed as part of next scheduled maintenance.	Remove trash and debris from wet swale.

Recommended Frequency	Drainage System Feature	Date	Problem	Conditions to Check For	Maintenance Activities and Conditions that Should Exist
Monthly from Oct. – Apr. and after any major storm event (1” in 24 hours)	General		Erosion/ Scouring	Swale has eroded or scoured due to flow channelization, or higher flows.	Check design flows to assure swale is large enough to handle flows. By-pass excess flows or enlarge swale. Replant eroded areas with fibrous-rooted plants such as Juncus effusus (soft rush) in wet areas or snowberry (Symphoricarpos albus) in drier areas, or as recommended by a wetland specialist.
Annually (preferably Sept.)	General		Insects	When insects such as wasps and hornets interfere with maintenance activities.	Insects destroyed or removed from site. Apply insecticides in compliance with adopted integrated pest management policies.

If you are unsure whether a problem exists, please contact Environmental Services at 253.591.5588.

Comments:

**#11 - Maintenance Checklist for Filter Strips**

Recommended Frequency	Drainage System Feature	Date	Problem	Conditions to Check For	Maintenance Activities and Conditions that Should Exist
Monthly from Oct. – Apr. and after any major storm event (1” in 24 hours)	General		Sediment Accumulation on Grass	Sediment depth exceeds 2 inches.	Remove sediment deposits, re-level so slope is even and flows pass evenly through strip.
Monthly from Oct. – Apr. and after any major storm event (1” in 24 hours)	General		Vegetation	When the grass becomes excessively tall (greater than 10 inches); when nuisance weeds and other vegetation start to take over.	Mow grass, control nuisance vegetation, such that flow not impeded. Grass should be mowed to a height between 3-4 inches.
Monthly from Oct. – Apr. and after any major storm event (1” in 24 hours)	General		Trash and Debris Accumulation	Trash and debris accumulated on the filter strip.	Remove trash and Debris from filter.
Monthly from Oct. – Apr. and after any major storm event (1” in 24 hours)	General		Erosion/ Scouring	Eroded or scoured areas due to flow channelization, or higher flows.	For ruts or bare areas less than 12 inches wide, repair the damaged area by filling with crushed gravel. The grass will creep in over the rock in time. If bare areas are large, generally greater than 12 inches wide, the filter strip should be re-graded and re- seeded. For smaller bare areas, overseed when bare spots are evident.
Monthly from Oct. – Apr. and after any major storm event (1” in 24 hours)	General		Flow spreader	Flow spreader uneven or clogged so that flows are not uniformly distributed through entire filter width.	Level the spreader and clean so that flows are spread evenly over entire filter width

Recommended Frequency	Drainage System Feature	Date	Problem	Conditions to Check For	Maintenance Activities and Conditions that Should Exist
Annually (preferably Sept.)	General		Insects	When insects such as wasps and hornets interfere with maintenance activities.	Insects destroyed or removed from site. Apply insecticides in compliance with adopted integrated pest management policies.

If you are unsure whether a problem exists, please contact Environmental Services at 253.591.5588.

Comments:

**#12 - Maintenance Checklist for Wet Ponds**

Recommended Frequency	Drainage System Feature	Date	Problem	Conditions to Check For	Maintenance Activities and Conditions that Should Exist
Monthly from Oct. – Apr. and after any major storm event (1" in 24 hours)	General		Water level	First cell is empty, doesn't hold water.	Line the first cell to maintain at least 4 feet of water. Although the second cell may drain, the first cell must remain full to control turbulence of the incoming flow and reduce sediment resuspension.
Monthly from Oct. – Apr. and after any major storm event (1" in 24 hours)			Trash and Debris	Accumulation that exceeds 1 cubic foot per 1000 square feet of pond area.	Trash and debris removed from pond
Biannually (Spring & Fall)	General		Poisonous Vegetation and Noxious Weeds	Any poisonous or nuisance vegetation which may constitute a hazard to maintenance personnel or the public. Any evidence of noxious weeds as defined in State and Local Regulations. (Apply requirements of adopted integrated vegetation management (IVM) policies for the use of herbicides.)	No danger of poisonous vegetation where maintenance personnel or the public might normally be. (Coordinate with the Pierce County Noxious Weed Control Board). Complete eradication of noxious weeds may not be possible, however compliance with state or local eradication policies are required.
Monthly from Oct. – Apr. and after any major storm event (1" in 24 hours)			Inlet/Outlet Pipe	Inlet and/or outlet pipe clogged with sediment and/or debris material	No clogging or blockage in the inlet and outlet piping.
Monthly from Oct. – Apr. and after any major storm event (1" in 24 hours)			Sediment Accumulation in Pond Bottom	Sediment accumulations in pond bottom that exceeds the depth of sediment zone plus 6 inches, usually in the first cell.	Sediment removed from pond bottom. (If sediment contamination is a potential problem, sediment should be tested regularly to determine leaching potential prior to disposal.)

Recommended Frequency	Drainage System Feature	Date	Problem	Conditions to Check For	Maintenance Activities and Conditions that Should Exist
Monthly			Vegetation	Vegetation is overgrown or sparse.	Trim vegetation as necessary to keep pond free of leaves and maintain aesthetic appearance. Revegetate bare sloped areas. Regrade before revegetation as needed.
Monthly from Oct. – Apr. and after any major storm event (1" in 24 hours)			Oil Sheen on Water	Prevalent and visible oil sheen.	Oil removed from water using oil- absorbent pads or vacuor truck. Source of oil located and corrected. If chronic low levels of oil persist, plant wetland plants such as Juncus effusus (soft rush) which can uptake small concentrations of oil.
Annually (preferably Sept.)			Erosion	Erosion of the pond's side slopes and/or scouring of the pond bottom that exceeds 6 inches, or where continued erosion is prevalent.	Slopes stabilized using proper erosion control measures and repair methods.
Annually (preferably Sept.)			Settlement of Pond Dike/ Berm	Any part of these components that has settled 4 inches or lower than the design elevation, or inspector determines dike/berm is unsound.	Dike/berm is repaired to specifications
Annually (preferably Sept.)			Internal Berm	Berm dividing cells should be level.	Berm surface is leveled so that water flows evenly over entire length of berm.
Annually (preferably Sept.)			Overflow Spillway	Rock is missing and soil is exposed at top of spillway or outside slope.	Rocks replaced to specifications.

Recommended Frequency	Drainage System Feature	Date	Problem	Conditions to Check For	Maintenance Activities and Conditions that Should Exist
Annually (preferably Sept.)	General		Insects	When insects such as wasps and hornets interfere with maintenance activities.	Insects destroyed or removed from site. Apply insecticides in compliance with adopted integrated pest management policies.

If you are unsure whether a problem exists, please contact Environmental Services at 253.591.5588.

Comments:

**#13 - Maintenance Checklist for Treatment Wetlands**

Recommended Frequency	Drainage System Feature	Date	Problem	Conditions to Check For	Maintenance Activities and Conditions that Should Exist
Biannually (Spring & Fall)	General		Trash and Debris	Any trash and debris accumulations which exceed 5 cubic feet per 1,000 square feet (this is a little more than the amount of trash it would take to fill up one standard 32 gallon garbage can). In general, there should be no visual evidence of dumping. If there is less than the threshold, remove all trash and debris as part of the next scheduled maintenance.	Trash and debris cleared from site.
Biannually (Spring & Fall)	General		Poisonous Vegetation and Noxious Weeds	Any poisonous or nuisance vegetation which may constitute a hazard to maintenance personnel or the public. Any evidence of noxious weeds as defined in State and Local Regulations. (Apply requirements of adopted integrated vegetation management (IVM) policies for the use of herbicides.)	No danger of poisonous vegetation where maintenance personnel or the public might normally be. (Coordinate with the Pierce County Noxious Weed Control Board). Complete eradication of noxious weeds may not be possible, however compliance with state or local eradication policies are required.
Biannually (Spring & Fall)	General		Oil Sheen on Water	Prevalent and visible oil sheen.	Oil removed from water using oil- absorbent pads or vacuor truck. Source of oil located and corrected. If chronic low levels of oil persist, plant emergent wetland plants such as Juncus effusus (soft rush) which can assist filtering small concentrations of oil.
Biannually (Spring & Fall) and after any major storm event (1" in 24 hours)	General		Inlet/Outlet Pipe	Inlet/Outlet pipe clogged with sediment and/or debris material or damaged.	No clogging or blockage in the inlet and outlet piping.



Recommended Frequency	Drainage System Feature	Date	Problem	Conditions to Check For	Maintenance Activities and Conditions that Should Exist
Biannually (Spring & Fall)	General		Rodent Holes	If the facility is constructed with a dam or berm, look for rodent holes or any evidence of water piping through the dam or berm.	Rodents removed and dam or berm repaired. (Coordinate with Ecology Dam Safety Office if pond exceeds 10 acre-feet.)
Biannually (Spring & Fall)	General		Beaver Dams	Beaver dam results in an adverse change in the functioning of the facility.	Facility is returned to design function. Contact WDFW to identify the appropriate Nuisance Wildlife Control Operator.
Biannually (Spring & Fall)	General		Tree Growth and Hazard Trees	Tree growth that impedes maintenance access.	Trees do not hinder maintenance activities. Harvested trees should be recycled into mulch or other beneficial uses.
Biannually (Spring & Fall)	General		Tree Growth and Hazard Trees	If dead, diseased, or dying trees are identified, use a Certified Arborist to determine the health of tree and whether removal is required.	Remove hazard trees.
Biannually (Spring & Fall)	General		Liner	Liner is visible and has more than three one-fourth inch holes in it.	Liner is repaired or replaced. Liner is fully covered.
Biannually (Spring & Fall)	Forebay		Sediment Accumulation	Sediment accumulation in forebay exceeds the design depth of the sediment zone plus 6 inches.	Accumulated sediment is removed from forebay bottom to the design depth of the sediment zone.
Biannually (Spring & Fall)	Side Slopes of Wetland		Erosion	Erosion damage over 2 inches deep where cause of damage is still present or where there is potential for continued erosion.	Slopes should be stabilized using appropriate erosion control measure(s) such as rock reinforcement, planting of grass, or additional compaction.
Biannually (Spring & Fall) and after any major storm event (1" in 24 hours)	Side Slopes of Wetland		Erosion	Any erosion observed on a compacted berm embankment over 2" deep.	If erosion is occurring on compacted berms a licensed Civil Engineer should be consulted to resolve source of erosion.

Recommended Frequency	Drainage System Feature	Date	Problem	Conditions to Check For	Maintenance Activities and Conditions that Should Exist
Biannually (Spring & Fall)	Wetland Cell		Wetland Vegetation	20 percent or more of the constructed wetland area has dead or dying vegetation, as measured by stem counts relative to the design plant coverage.	Dead or dying vegetation is replaced by like species, unless recommended otherwise by the Wetlands Consultant and approved by the City. (Watering, physical support, mulching, and weed removal may be required on a regular basis especially during the first 3 years.)
Biannually (Spring & Fall)	Wetland Cell		Wetland Vegetation	Percent vegetated cover of constructed wetland bottom area, excluding exotic and invasive species, is less than 50 percent after 2 years.	Remove exotic/invasive species, additional plantings may be required.
Biannually (Spring & Fall)	Wetland Cell		Wetland Vegetation	Decaying vegetation produces foul odors.	Decaying vegetation is removed, preferably in late summer.
Once in mid summer (July or August)	Wetland Cell		Wetland Vegetation	Wetland vegetation is blocking flowpaths causing flow back-up and flooding.	Areas of blocking vegetation are cut back sufficient to allow design flows and prevent flooding.

Recommended Frequency	Drainage System Feature	Date	Problem	Conditions to Check For	Maintenance Activities and Conditions that Should Exist
Annually (preferably Sept.)	Wetland Cell		Wetland Vegetation	Water quality monitoring indicates that wetland vegetation is contributing phosphorus and metals to downstream waters rather than sequestering them. Environmental Services will determine when water quality monitoring is required.	To maximize removal of wetland pollutants, vegetation must be periodically harvested, particularly with respect to phosphorus and metals removal. Harvesting should occur by mid-summer before plants begin to transfer phosphorus from the aboveground foliage to subsurface roots, or begin to lose metals that desorb during plant die off. Every 3 to 5 years the entire plant mass including roots should be harvested because the below ground biomass constitutes a significant reservoir (as much as half) of the nutrients and metals that are removed from stormwater by plants.
Biannually (Spring & Fall)	Wetland Cell		Sediment Accumulation	Sediment accumulation inhibits growth of wetland plants or reduces wetland volume (greater than 1 foot of sediment accumulation).	Dredge to design depth.
Annually (preferably Sept.)	Wetland Berms (Dikes)		Settlements	Any part of berm which has settled 4 inches lower than the design elevation. If settlement is apparent, measure berm to determine amount of settlement. Settling can be an indication of more severe problems with the berm or outlet works. A licensed Civil Engineer should be consulted to determine the source of the settlement.	Dike restored to the design elevation.

Recommended Frequency	Drainage System Feature	Date	Problem	Conditions to Check For	Maintenance Activities and Conditions that Should Exist
Annually (preferably Sept.)	Wetland Berms (Dikes)		Piping	Discernable water flow through pond berm. Ongoing erosion with potential for erosion to continue. (Recommend a Geotechnical Engineer be called in to inspect and evaluate condition and recommend repairs.	Piping eliminated. Erosion potential eliminated.
Annually (preferably Sept.)	Wetland Berms over 4 ft in height (Dikes)		Tree Growth	Tree growth on berms over 4 feet in height may lead to piping through the berm which could lead to failure of the berm.	Trees should be removed. If root system is small (base less than 4 inches) the root system may be left in place. Otherwise the roots should be removed and the berm restored. A licensed Civil Engineer should be consulted for proper berm/spillway restoration.
Annually (preferably Sept.)	Emergency Overflow/Spillway		Obstruction	Tree growth or other blockage on emergency spillways may cause failure of the berm due to uncontrolled overtopping.	Obstruction should be removed. A licensed Civil Engineer should be consulted for proper berm/spillway restoration.
Annually (preferably Sept.)	Emergency Overflow/Spillway		Rock Missing	Only one layer of rock exists above native soil in an area 5 square feet or larger, or any exposure of native soil at the top of outflow path of spillway. (Riprap on inside slopes need not be replaced.)	Rocks and pad depth are restored to design standards.
Annually (preferably Sept.)	Emergency Overflow/Spillway		Erosion	Erosion damage over 2 inches deep where cause of damage is still present or where there is potential for continued erosion. Any erosion observed on a compacted berm embankment.	Slopes should be stabilized using appropriate erosion control measure(s); e.g., rock reinforcement, planting of grass, compaction. If erosion is occurring on compacted berms a licensed Civil Engineer should be consulted to resolve source of erosion.

Recommended Frequency	Drainage System Feature	Date	Problem	Conditions to Check For	Maintenance Activities and Conditions that Should Exist
Annually (preferably Sept.)	General		Insects	When insects such as wasps and hornets interfere with maintenance activities.	Insects destroyed or removed from site. Apply insecticides in compliance with adopted integrated pest management policies.

If you are unsure whether a problem exists, please contact Environmental Services at 253.591.5588.

Comments:

**#14 - Maintenance Checklist for Wet Vaults**

Recommended Frequency	Drainage System Feature	Date	Problem	Conditions to Check For	Maintenance Activities and Conditions that Should Exist
Monthly from Oct. – Apr. and after any major storm event (1" in 24 hours)	General		Trash/Debris Accumulation	Trash and debris accumulated in vault, pipe or inlet/outlet (includes floatables and non-floatables).	Remove trash and debris from vault.
Monthly from Oct. – Apr. and after any major storm event (1" in 24 hours)	General		Sediment Accumulation in Vault	Sediment accumulation in vault bottom exceeds the depth of the sediment zone plus 6 inches.	Remove sediment from vault. (If sediment contamination is a potential problem, sediment should be tested regularly to determine leaching potential prior to disposal.)
Annually (preferably Sept.)	General		Damaged Pipes	Inlet/outlet piping damaged or broken and in need of repair.	Pipe repaired and/or replaced.
Annually (preferably Sept.)	General		Access Cover Damaged/Not Working	Cover cannot be opened or removed, especially by one person.	Pipe repaired or replaced to proper working specifications.
Monthly from Oct. – Apr. and after any major storm event (1" in 24 hours)	General		Ventilation	Ventilation area blocked or plugged.	Blocking material removed or cleared from ventilation area. A specified percentage of the vault surface area must provide ventilation to the vault interior (see design specifications).
Annually (preferably Sept.)	Vault Structure		Damage - Includes Cracks in Walls/Bottom, Damage to Frame and/or Top Slab	Maintenance/inspection personnel determine that the vault is not structurally sound	Vault replaced or repairs made so that vault meets design specifications and is structurally sound.
Annually (preferably Sept.)	Vault Structure		Damage - Includes Cracks in Walls/Bottom, Damage to Frame and/or Top Slab	Cracks wider than one-half-inch at the joint of any inlet/outlet pipe or evidence of soil particles entering through the cracks.	Vault repaired so that no cracks exist wider than one-fourth inch at the joint of the inlet/outlet pipe.
Annually (preferably Sept.)	Vault Structure		Baffles	Baffles corroding, cracking, warping and/or showing signs of failure as determined by maintenance/inspection staff.	Baffles repaired or replaced to specifications.

Recommended Frequency	Drainage System Feature	Date	Problem	Conditions to Check For	Maintenance Activities and Conditions that Should Exist
Annually (preferably Sept.)	Access Ladder		Damage	Ladder is corroded or deteriorated, not functioning properly, not attached to structure wall, missing rungs, has cracks and/or misaligned. Confined space warning sign missing.	Ladder replaced or repaired to specifications, and is safe to use as determined by inspection personnel. Replace sign warning of confined space entry requirements.
Annually (preferably Sept.)	General		Insects	When insects such as wasps and hornets interfere with maintenance activities.	Insects destroyed or removed from site. Apply insecticides in compliance with adopted integrated pest management policies.

If you are unsure whether a problem exists, please contact Environmental Services at 253.591.5588.

A vault is a confined space. Visual inspections should be performed aboveground. If entry is required it should be performed by qualified personnel.

Comments:

**#15 - Maintenance Checklist for Sand Filters (above ground/open)**

Recommended Frequency	Drainage System Feature	Date	Problem	Conditions to Check For	Maintenance Activities and Conditions that Should Exist
Monthly from Oct. – Apr. and after any major storm event (1" in 24 hours)	Above ground (open sand filter)		Sediment Accumulation on top layer	Sediment depth exceeds one-half inch.	No sediment deposit on grass layer of sand filter that would impede permeability of the filter section.
Monthly from Oct. – Apr. and after any major storm event (1" in 24 hours)	Above ground (open sand filter)		Trash and Debris Accumulations	Trash and debris accumulated on sand filter bed.	Trash and debris removed from sand filter bed.
Monthly from Oct. – Apr. and after any major storm event (1" in 24 hours)	Above ground (open sand filter)		Sediment/ Debris in Clean-Outs	When the clean-outs become full or partially plugged with sediment and/or debris.	Sediment removed from clean-outs.
Monthly from Oct. – Apr. and after any major storm event (1" in 24 hours)	Above ground (open sand filter)		Sand Filter Media	Drawdown of water through the sand filter media takes longer than 24-hours, and/or flow through the overflow pipes occurs frequently.	Top several inches of sand are scraped. May require replacement of entire sand filter depth depending on extent of plugging (a sieve analysis is helpful to determine if the lower sand has too high a proportion of fine material). Other options include removal of thatch, aerating the filter surface, tilling the filter surface, replacing the top 4 inches of filter media, and inspecting geotextiles for clogging.
Monthly from Oct. – Apr. and after any major storm event (1" in 24 hours)	Above ground (open sand filter)		Prolonged Flows	Sand is saturated for prolonged periods of time (several weeks) and does not dry out between storms due to continuous base flow or prolonged flows from detention facilities. (Consider 4-8 hour drawdown tests)	Low, continuous flows are limited to a small portion of the facility by using a low wooden divider or slightly depressed sand surface.



Recommended Frequency	Drainage System Feature	Date	Problem	Conditions to Check For	Maintenance Activities and Conditions that Should Exist
Monthly from Oct. – Apr. and after any major storm event (1” in 24 hours)	Above ground (open sand filter)		Short Circuiting	Drawdown greater than 12 inches per hour. When flows become concentrated over one section of the sand filter rather than dispersed. (Consider 4-8 hour drawdown tests)	Flow and percolation of water through sand filter is uniform and dispersed across the entire filter area. Inspect periphery and cleanouts for leakage.
Monthly from Oct. – Apr. and after any major storm event (1” in 24 hours)	Above ground (open sand filter)		Erosion Damage to Slopes	Erosion over 2 inches deep where cause of damage is prevalent or potential for continued erosion is evident.	Slopes stabilized using proper erosion control measures.
Annually (preferably Sept.)	Above ground (open sand filter)		Rock Pad Missing or Out of Place	Soil beneath the rock is visible.	Rock pad replaced or rebuilt to design specifications.
Monthly from Oct. – Apr. and after any major storm event (1” in 24 hours)	Above ground (open sand filter)		Flow Spreader	Flow spreader uneven or clogged so that flows are not uniformly distributed across sand filter. Rills and gullies on the surface of the filter can indicate improper function of the inlet flow spreader.	Spreader leveled and cleaned so that flows are spread evenly over sand filter. Refill rills and gullies with sand.
Monthly from Oct. – Apr. and after any major storm event (1” in 24 hours)	Above ground (open sand filter)		Damaged Pipes	Any part of the piping that is crushed or deformed more than 20 percent or any other failure to the piping.	Pipe repaired or replaced.
Annually (preferably Sept.)	General		Insects	When insects such as wasps and hornets interfere with maintenance activities.	Insects destroyed or removed from site. Apply insecticides in compliance with adopted integrated pest management policies.
Every other year	General		Drawdown		Every two years conduct a drawdown test by filling the filter with water and measuring the decline in water level over a 4 - 8 hour period.

If you are unsure whether a problem exists, please contact Environmental Services at 253.591.5588.

Comments:

**#16 - Maintenance Checklist for Sand Filters (below ground/enclosed)**

Recommended Frequency	Drainage System Feature	Date	Problem	Conditions to Check For	Maintenance Activities and Conditions that Should Exist
Monthly from Oct. – Apr. and after any major storm event (1" in 24 hours)	Below Ground Vault		Sediment Accumulation on Sand Media Section	Sediment depth exceeds one-half inch.	No sediment deposits on sand filter section that would impede permeability of the filter section.
Monthly from Oct. – Apr. and after any major storm event (1" in 24 hours)	Below Ground Vault		Sediment Accumulation in Presettling Portion of Vault	Sediment accumulation in vault bottom exceeds the depth of the sediment zone plus 6 inches.	No sediment deposits in first chamber of vault.
Monthly from Oct. – Apr. and after any major storm event (1" in 24 hours)	Below Ground Vault		Trash/Debris Accumulation	Trash and debris accumulated in vault, or pipe inlet/outlet, floatables and non-floatables.	Trash and debris removed from vault and inlet/outlet piping.
Monthly from Oct. – Apr. and after any major storm event (1" in 24 hours)	Below Ground Vault		Sediment in Drain Pipes/ Cleanouts	When drain pipes, cleanouts become full with sediment and/or debris.	Sediment and debris removed.
Monthly from Oct. – Apr. and after any major storm event (1" in 24 hours)	Below Ground Vault		Clogged Sand Filter Media	Drawdown of water through the sand filter media takes longer than 24-hours, and/or flow through the overflow pipes occurs frequently. (Consider 4-8 hour drawdown tests.)	Top several inches of sand are scraped. May require replacement of entire sand filter depth depending on extent of plugging (a sieve analysis is helpful to determine if the lower sand has too high a proportion of fine material). Other options include removal of thatch, aerating the filter surface, tilling the filter surface, and replacing the top 4 inches of filter media.
Monthly from Oct. – Apr. and after any major storm event (1" in 24 hours)	Below Ground Vault		Short Circuiting	Drawdown greater than 12 inches per hour. When seepage/flow occurs along the vault walls and corners. Sand eroding near inflow area. (Consider 4-8 hour drawdown tests.)	Sand filter media section re-laid and compacted along perimeter of vault to form a semi-seal. Erosion protection added to dissipate force of incoming flow and curtail erosion.

Recommended Frequency	Drainage System Feature	Date	Problem	Conditions to Check For	Maintenance Activities and Conditions that Should Exist
Annually (preferably Sept.)	Below Ground Vault		Damaged Pipes	Inlet or outlet piping damaged or broken and in need of repair.	Pipe repaired and/or replaced.
Monthly from Oct. – Apr. and after any major storm event (1" in 24 hours)	Below Ground Vault		Flow Spreader	Flow spreader uneven or clogged so that flows are not uniformly distributed across sand filter.	Spreader leveled and cleaned so that flows are spread evenly over sand filter.
Monthly from Oct. – Apr. and after any major storm event (1" in 24 hours)	Below Ground Vault		Ventilation	Ventilation area blocked or plugged	Blocking material removed or cleared from ventilation area. A specified percentage of the vault surface area must provide ventilation to the vault interior (see design specifications).
Annually (preferably Sept.)	Below Ground Vault		Access Cover Damaged/Not Working	Cover cannot be opened, corrosion/deformation of cover. Maintenance person cannot remove cover using normal lifting pressure.	Cover repaired to proper working specifications or replaced.
Annually (preferably Sept.)	Below Ground Vault		Vault Structure Damaged; Includes Cracks in Walls, Bottom, Damage to Frame and/or Top Slab.	Cracks wider than one-half inch or evidence of soil particles entering the structure through the cracks, or maintenance/inspection personnel determine that the vault is not structurally sound.	Vault replaced or repairs made so that vault meets design specifications and is structurally sound.
Annually (preferably Sept.)	Below Ground Vault		Vault Structure Damaged; Includes Cracks in Walls, Bottom, Damage to Frame and/or Top Slab.	Cracks wider than one-half inch at the joint of any inlet/outlet pipe or evidence of soil particles entering through the cracks.	Vault repaired so that no cracks exist wider than one-fourth inch at the joint of the inlet/outlet pipe.
Annually (preferably Sept.)	Below Ground Vault		Baffles/Internal walls	Baffles or walls corroding, cracking, warping and/or showing signs of failure as determined by maintenance/inspection person.	Baffles repaired or replaced to specifications.

Recommended Frequency	Drainage System Feature	Date	Problem	Conditions to Check For	Maintenance Activities and Conditions that Should Exist
Annually (preferably Sept.)	Below Ground Vault		Access Ladder	Damaged ladder is corroded or deteriorated, not functioning properly, not securely attached to structure wall, missing rungs, cracks, and misaligned.	Ladder replaced or repaired to specifications, and is safe to use as determined by inspection personnel.
Annually (preferably Sept.)	General		Insects	When insects such as wasps and hornets interfere with maintenance activities.	Insects destroyed or removed from site. Apply insecticides in compliance with adopted integrated pest management policies.

If you are unsure whether a problem exists, please contact Environmental Services at 253.591.5588.

A below ground enclosed sand filter is a confined space. Visual inspections should be performed aboveground. If entry is required it should be performed by qualified personnel.

Comments:

### #17 - Maintenance Checklist for Baffle Oil/Water Separators - American Petroleum Institute (API) Type

Recommended Frequency	Drainage System Feature	Date	Problem	Conditions to Check For	Maintenance Activities and Conditions that Should Exist
Monthly from Oct. – Apr. and after any major storm event (1" in 24 hours)	Monitoring		Inspection of discharge water for obvious signs of poor water quality.	Sheen, obvious oil present in discharge.	Effluent discharge from vault should be clear without visible sheen.
Monthly from Oct. – Apr. and after any major storm event (1" in 24 hours)	Monitoring		Sediment Accumulation	Sediment depth in bottom of vault exceeds 6 inches in depth.	No sediment deposits on vault bottom that would impede flow through the vault and reduce separation efficiency.
Monthly from Oct. – Apr. and after any major storm event (1" in 24 hours)	Monitoring		Trash and Debris Accumulation	Trash and debris accumulation in vault, or pipe inlet/outlet, floatables and non-floatables.	Trash and debris removed from vault, and inlet/outlet piping.
Monthly from Oct. – Apr. and after any major storm event (1" in 24 hours)	Monitoring		Oil Accumulation	Oil accumulations that exceed 1 inch, at the surface of the water or 6 inches of sludge in the sump.	Extract oil/sludge from vault by vactoring. Dispose of in accordance with state and local rules and regulations. Clean separators by October 15 to remove material accumulated during the dry season. Clean separators after spills. Replace wash water with clean water before returning to service.
Annually (preferably Sept.)	Structure		Damaged Pipes	Inlet or outlet piping damaged or broken and in need of repair.	Pipe repaired or replaced.
Annually (preferably Sept.)	Structure		Access Cover Damaged/Not Working	Cover cannot be opened, corrosion/deformation of cover.	Cover repaired to proper working specifications or replaced.
Annually (preferably Sept.)	Structure		Vault Structure Damage Includes Cracks in Walls/Bottom, Damage to Frame and/or Top Slab	Maintenance person judges that structure is unsound.	Vault replaced or repairs made so that vault meets design specifications and is structurally sound.

Recommended Frequency	Drainage System Feature	Date	Problem	Conditions to Check For	Maintenance Activities and Conditions that Should Exist
Annually (preferably Sept.)	Structure		Vault Structure Damage Includes Cracks in Walls/Bottom, Damage to Frame and/or Top Slab	Cracks wider than one-half inch at the joint of any inlet/outlet pipe or evidence of soil particles entering through the cracks.	Vault repaired so that no cracks exist wider than one-fourth inch at the joint of the inlet/outlet pipe.
Annually (preferably Sept.)	Structure		Baffles	Baffles corroding, cracking, warping and/or showing signs of failure as determined by maintenance/inspection person.	Baffles repaired or replaced to specifications.
Annually (preferably Sept.)	Structure		Access Ladder Damaged	Ladder is corroded or deteriorated, not functioning properly, not securely attached to structure wall, missing rungs, cracks, and misaligned.	Ladder replaced or repaired and meets specifications, and is safe to use as determined by inspection personnel.
Annually (preferably Sept.)	General		Insects	When insects such as wasps and hornets interfere with maintenance activities.	Insects destroyed or removed from site. Apply insecticides in compliance with adopted integrated pest management policies.

If you are unsure whether a problem exists, please contact Environmental Services at 253.591.5588.

An oil/water separator vault is a confined space. Visual inspections should be performed aboveground. If entry is required it should be performed by qualified personnel.

Comments:

**#18 - Maintenance Checklist for Coalescing Plate Oil/Water Separators**

Recommended Frequency	Drainage System Feature	Date	Problem	Conditions to Check For	Maintenance Activities and Conditions that Should Exist
Monthly from Oct. – Apr. and after any major storm event (1” in 24 hours)	General		Inspection of discharge water for obvious signs of poor water quality.	Sheen, obvious oil present in discharge.	Effluent discharge from vault should be clear with no visible sheen.
Monthly from Oct. – Apr. and after any major storm event (1” in 24 hours)	General		Sediment Accumulation	Sediment depth in bottom of vault exceeds 6 inches in depth and/or visible signs of sediment on plates.	No sediment deposits on vault bottom and plate media, which would impede flow through the vault and reduce separation efficiency.
Monthly from Oct. – Apr. and after any major storm event (1” in 24 hours)	General		Trash and Debris Accumulation	Trash and debris accumulated in vault, or pipe inlet/outlet, floatables and non-floatables.	Trash and debris removed from vault, and inlet/outlet piping.
Monthly from Oct. – Apr. and after any major storm event (1” in 24 hours)	General		Oil Accumulation	Oil accumulation that exceeds 1 inch at the water surface.	Oil is extracted from vault using vacuoring methods. Dispose of in accordance with state and local rules and regulations.  Coalescing plates are cleaned by thoroughly rinsing and flushing. Direct wash-down effluent to the sanitary sewer system where permitted. Should be no visible oil depth on water. Clean separators by October 15 to remove material accumulated during the dry season. Clean separators after spills. Replace wash water with clean water before returning to service.
Annually (preferably Sept.)	Structure		Damaged Coalescing Plates	Plate media broken, deformed, cracked and/ or showing signs of failure.	A portion of the media pack or the entire plate pack is replaced depending on severity of failure.

Recommended Frequency	Drainage System Feature	Date	Problem	Conditions to Check For	Maintenance Activities and Conditions that Should Exist
Annually (preferably Sept.)	Structure		Damaged Pipes	Inlet or outlet piping damaged or broken and in need of repair.	Pipe repaired and or replaced.
Annually (preferably Sept.)	Structure		Baffles	Baffles corroding, cracking, warping and/or showing signs of failure as determined by maintenance/inspection person.	Baffles repaired or replaced per specifications.
Annually (preferably Sept.)	Structure		Vault Structure Damage - Includes Cracks in Walls, Bottom, Damage to Frame and/or Top Slab	Cracks wider than one-half inch or evidence of soil particles entering the structure through the cracks, or maintenance/inspection personnel determine that the vault is not structurally sound.	Vault replaced or repairs made so that vault meets design specifications and is structurally sound.
Annually (preferably Sept.)	Structure		Vault Structure Damage - Includes Cracks in Walls, Bottom, Damage to Frame and/or Top Slab	Cracks wider than one-half inch at the joint of any inlet/outlet pipe or evidence of soil particles entering through the cracks.	Vault repaired so that no cracks exist wider than one-fourth inch at the joint of the inlet/outlet pipe.
Annually (preferably Sept.)	Structure		Access Ladder Damaged	Ladder is corroded or deteriorated, not functioning properly, not securely attached to structure wall, missing rungs, cracks, and misaligned.	Ladder replaced or repaired and meets specifications, and is safe to use as determined by inspection personnel.
Annually (preferably Sept.)	General		Insects	When insects such as wasps and hornets interfere with maintenance activities.	Insects destroyed or removed from site. Apply insecticides in compliance with adopted integrated pest management policies.

If you are unsure whether a problem exists, please contact Environmental Services at 253.591.5588.

An oil/water separator vault is a confined space. Visual inspections should be performed aboveground. If entry is required it should be performed by qualified personnel.

Comments:



**#19 - Maintenance Checklist for Fencing/Shrubbery Screen/Other Landscaping**

Recommended Frequency	Drainage System Feature	Date	Problem	Conditions to Check For	Maintenance Activities and Conditions that Should Exist
Monthly from Oct. – Apr.	General		Missing or broken parts/dead shrubbery	Any defect in the fence or screen that permits easy entry to a facility.	Fence is mended or shrubs replaced to form a solid barrier to entry.
Monthly from Oct. – Apr. and after any major storm event (1" in 24 hours)	General		Erosion	Erosion has resulted in an opening under a fence that allows entry by people or pets.	Replace soil under fence so that no opening exceeds 4 inches in height.
Monthly from Oct. – Apr.	General		Unruly Vegetation	Shrubbery is growing out of control or is infested with weeds.	Shrubbery is trimmed and weeded to provide appealing aesthetics. Do not use chemicals to control weeds.
Annually (preferably Sept.)	Fences		Damaged Parts	Posts out of plumb more than 6 inches.	Posts are within 1.5 inches of plumb.
Annually (preferably Sept.)	Fences		Damaged Parts	Top rails bent more than 6 inches.	Top rail free of bends greater than 1 inch.
Annually (preferably Sept.)	Fences		Damaged Parts	Any part of fence (including posts, top rails, and fabric) more than 1 foot out of design alignment.	Fence is aligned and meets design standards.
Annually (preferably Sept.)	Fences		Damaged Parts	Missing or loose tension wire.	Tension wire in place and holding fabric.
Annually (preferably Sept.)	Fences		Damaged Parts	Missing or loose barbed wire that is sagging more than 2.5 inches between posts.	Barbed wire in place with less than three-fourth inch sag between posts.
Annually (preferably Sept.)	Fences		Damaged Parts	Extension arm missing, broken, or bent out of shape more than 1.5 inches.	Extension arm in place with no bends larger than three-fourth inch.
Annually (preferably Sept.)	Fences		Deteriorated Paint or Protective Coating	Part or parts that have a rusting or scaling condition that has affected structural adequacy.	Structurally adequate posts or parts with a uniform protective coating.
Annually (preferably Sept.)	General		Insects	When insects such as wasps and hornets interfere with maintenance activities.	Insects destroyed or removed from site. Apply insecticides in compliance with adopted integrated pest management policies.

If you are unsure whether a problem exists, please contact Environmental Services at 253.591.5588.

Comments:

**#20 - Maintenance Checklist for Gates**

Recommended Frequency	Drainage System Feature	Date	Problem	Conditions to Check For	Maintenance Activities and Conditions that Should Exist
Monthly from Oct. – Apr.	General		Damaged or Missing Components	Gate is broken, jammed, or missing.	Pond has a functioning gate to allow entry of people and maintenance equipment such as mowers and backhoe. If a lock is used, make sure the City field staff have a key.
Monthly from Oct. – Apr.	General		Damaged or Missing Components	Broken or missing hinges such that gate cannot be easily opened and closed by one maintenance person.	Hinges intact and lubed. Gate is working freely.
Annually (preferably Sept.)	General		Damaged or Missing Components	Gate is out of plumb more than 6 inches and more than 1 foot out of design alignment.	Gate is aligned and vertical.
Annually (preferably Sept.)	General		Damaged or Missing Components	Missing stretcher bands, and ties.	Stretcher bar, bands, and ties in place.
Annually (preferably Sept.)	General		Insects	When insects such as wasps and hornets interfere with maintenance activities.	Insects destroyed or removed from site. Apply insecticides in compliance with adopted integrated pest management policies.

If you are unsure whether a problem exists, please contact Environmental Services at 253.591.5588.

Comments:

**#21 - Maintenance Checklist for Grounds (Landscaping)**

Recommended Frequency	Drainage System Feature	Date	Problem	Conditions to Check For	Maintenance Activities and Conditions that Should Exist
Monthly from Oct. – Apr.	General		Weeds (non-poisonous)	Weeds growing in more than 20 percent of the landscaped area (trees and shrubs only).	Weeds present in less than 5 percent of the landscaped area.
Biannually (Spring & Fall)	General		Poisonous Vegetation and Noxious Weeds	Any poisonous or nuisance vegetation which may constitute a hazard to maintenance personnel or the public. Any evidence of noxious weeds as defined in State and Local Regulations. (Apply requirements of adopted integrated vegetation management (IVM) policies for the use of herbicides.)	No danger of poisonous vegetation where maintenance personnel or the public might normally be. (Coordinate with the Pierce County Noxious Weed Control Board). Complete eradication of noxious weeds may not be possible, however compliance with state or local eradication policies are required.
Annually (preferably Sept.)	General		Insects	When insects such as wasps and hornets interfere with maintenance activities.	Insects destroyed or removed from site. Apply insecticides in compliance with adopted integrated pest management policies.
Monthly from Oct. – Apr. and after any major storm event (1" in 24 hours)	General		Trash and Debris	Any trash and debris which exceeds 5 cubic feet per 1,000 square feet (this is about equal to the amount of trash it would take to fill up one 32 gallon garbage can). In general, there should be no visual evidence of dumping.	Trash and debris cleared from site.
Monthly from Oct. – Apr. and after any major storm event (1" in 24 hours)	General		Erosion of Ground Surface	Noticeable rills are seen in landscaped areas.	Causes of erosion are identified and steps taken to slow down/ spread out the water. Eroded areas are filled, contoured, and seeded.
Annually (preferably Sept.)	Trees and shrubs		Damage	Limbs or parts of trees or shrubs that are split or broken which affect more than 25 percent of the total foliage of the tree or shrub.	Trim trees/shrubs to restore shape. Replace severely damaged trees/shrubs.

Recommended Frequency	Drainage System Feature	Date	Problem	Conditions to Check For	Maintenance Activities and Conditions that Should Exist
Monthly from Oct. – Apr.	Trees and shrubs		Damage	Trees or shrubs that have been blown down or knocked over.	Replant tree, inspecting for injury to stem or roots. Replace if severely damaged.
Annually (preferably Sept.)	Trees and shrubs		Damage	Trees or shrubs which are not adequately supported or are leaning over, causing exposure of the roots.	Place stakes and rubber-coated ties around young trees/shrubs for support.

If you are unsure whether a problem exists, please contact Environmental Services at 253.591.5588.

Comments:

**#22 - Maintenance Checklist for Bioretention Facilities**

Recommended Frequency	Drainage System Feature	Date	Problem	Conditions to Check For	Maintenance Activities and Conditions that Should Exist
Biannually and After Major Storm Events	Earthen side slopes and berms		Failure in earthen reservoir	Erosion (gullies/rills) greater than 2 inches deep around inlets, outlet and alongside slopes.	Eliminate cause of erosion and stabilize damaged area (regrade, rock, vegetation, erosion control matting).  For deep channels or cuts (over 3 inches in ponding depth), temporary erosion control measures should be put in place until permanent repairs can be made.  Properly designed, constructed and established facilities with appropriate flow velocities should not have erosion problems except perhaps in extreme events. If erosion problems persist, the following should be reassessed: (1) flow volumes from contributing areas and bioretention facility sizing; (2) flow velocities and gradients within the facility; and (3) flow dissipation and erosion protection strategies at the facility inlet.
Annually	Earthen side slopes and berms		Failure in earthen reservoir	Erosion of sides causes slope to become a hazard.	Take actions to eliminate the hazard and stabilize slopes.
Annually and After Major Storm Events	Earthen side slopes and berms		Failure in earthen reservoir	Settlement greater than 3 inches (relative to undisturbed sections of the berm).	Restore to design height.
Annually and After Major Storm Events	Earthen side slopes and berms		Failure in earthen reservoir	Downstream face of berm wet, seeps or leaks evident.	Plug any holes and compact berm (may require consultation with engineer, particularly for larger berms).

Recommended Frequency	Drainage System Feature	Date	Problem	Conditions to Check For	Maintenance Activities and Conditions that Should Exist
Annually	Earthen side slopes and berms		Failure in earthen reservoir	Any evidence of rodent holes or water piping in berm.	Eradicate rodents (see "Pest control"). Fill holes and compact (may require consultation with engineer, particularly for larger berms).
Annually	Concrete sidewalls		Failure in sidewalls	Cracks or failure of concrete sidewalls.	Repair/seal cracks. Replace if repair is insufficient.
Annually	Rockery sidewalls		Failure in sidewalls	Rockery side walls are insecure.	Stabilize rockery sidewalls (may require consultation with engineer particularly for walls 4 feet or greater in height).
As Needed	Facility area		Accumulation of sediment or debris	Trash and debris present.	Clean out trash and debris.
Annually and After Major Storm Events	Facility bottom area		Accumulation of sediment or debris	Accumulated sediment to the extent that infiltration rate is reduced (See "Ponded water") or surface storage capacity significantly impacted.	Remove excess sediment. Replace any vegetation damaged or destroyed by sediment accumulation and removal. Mulch newly planted vegetation. Identify and control the sediment source (if feasible). If accumulated sediment is recurrent, consider adding presettlement or installing berms to create a forebay at the inlet.
As Needed During and After Fall Leaf Drop	Facility bottom area		Accumulation of sediment or debris	Accumulated leaves in facility.	Remove leaves if there is a risk to clogging outlet structure or water flow is impeded.
Annually and After Major Storm Events	Low permeability check dams and weirs		Accumulation of sediment or debris	Sediment, vegetation, or debris accumulated at or blocking (or having the potential to block) check dam, flow control weir or orifice.	Clear the blockage.

Recommended Frequency	Drainage System Feature	Date	Problem	Conditions to Check For	Maintenance Activities and Conditions that Should Exist
Annually and After Major Storm Events	Low permeability check dams and weirs		Failure of check dams and weirs	Erosion and/or undercutting present.	Repair and take preventative measures to prevent future erosion and/or undercutting.
Annually	Low permeability check dams and weirs		Failure of check dams and weirs	Grade board or top of weir damaged and not level.	Restore to level position.

Recommended Frequency	Drainage System Feature	Date	Problem	Conditions to Check For	Maintenance Activities and Conditions that Should Exist
Biannually and After Major Storm Events	Ponded water		Water remains in bioretention facility after storm event	Excessive ponding water: Water overflows during storms smaller than the design event or ponded water remains in the basin 48 hours or longer after the end of a storm.	<p>Determine cause and resolve in the following order:</p> <ol style="list-style-type: none"> <li>1) Confirm leaf or debris buildup in the bottom of the facility is not impeding infiltration. If necessary, remove leaf litter/debris.</li> <li>2) Ensure that underdrain (if present) is not clogged. If necessary, clear underdrain.</li> <li>3) Check for other water inputs (e.g., groundwater, illicit connections).</li> <li>4) Verify that the facility is sized appropriately for the contributing area. Confirm that the contributing area has not increased.</li> </ol> <p>If steps #1-4 do not solve the problem, the bioretention soil is likely clogged by sediment accumulation at the surface or has become overly compacted. Dig a small hole to observe soil profile and identify compaction depth or clogging front to help determine the soil depth to be removed or otherwise rehabilitated (e.g., tilled). Consultation with an engineer is recommended.</p>



Recommended Frequency	Drainage System Feature	Date	Problem	Conditions to Check For	Maintenance Activities and Conditions that Should Exist
As needed	Bioretention soil media			Bioretention soil media protection is needed when performing maintenance requiring entrance into the facility footprint.	Minimize all loading in the facility footprint (foot traffic and other loads) to the degree feasible in order to prevent compaction of bioretention soils. Never drive equipment or apply heavy loads in facility footprint. Because the risk of compaction is higher during saturated soil conditions, any type of loading in the cell (including foot traffic) should be minimized during wet conditions. Consider measures to distribute loading if heavy foot traffic is required or equipment must be placed in facility. As an example, boards may be placed across soil to distribute loads and minimize compaction. If compaction occurs, soil must be loosened or otherwise rehabilitated to original design state.
Annually	Splash block inlet		Inlet Failure	Water is not being directed properly to the facility and away from the inlet structure.	Reconfigure/repair blocks to direct water to facility and away from structure.
Monthly during the wet season and before severe storm is forecasted	Curb cut inlet/outlet		Inlet Clogged	Accumulated leaves at curb cuts.	Clear leaves (particularly important for key inlet and low points along long, linear facilities).
Annually	Pipe inlet/outlet		Inlet Pipe Structure Failure	Pipe is damaged.	Repair/replace.
Annually During the Wet Season	Pipe inlet/outlet		Inlet Pipe Clogged	Pipe is clogged.	Remove roots or debris.

Recommended Frequency	Drainage System Feature	Date	Problem	Conditions to Check For	Maintenance Activities and Conditions that Should Exist
Annually and After Major Storm Events	Pipe inlet/outlet		Inlet Pipe Clogged	Sediment, debris, trash or mulch reducing capacity of inlet/outlet.	Clear the blockage. Identify the source of the blockage and take actions to prevent future blockages.
Weekly During Fall Leaf Drop	Pipe inlet/outlet		Inlet Clogged	Accumulated leaves at the inlets/outlets.	Clear leaves (particularly important for key inlets and low points along long, linear facilities).
Annually	Pipe inlet/outlet		Inlet Blocked	Maintain access for inspections.	Clear vegetation (transplant vegetation when possible) within 1 foot of inlets and outlets, maintain access pathways. Consultation with a landscape architect is recommended for removal, transplant, or substitution of plants.
After Major Storm Events	Trash rack		Trash Rack clogged	Trash or other debris present on trash rack.	Remove/dispose.
Annually	Trash rack		Trash Rack Damaged	Bar screen damaged or missing.	Repair/replace.
Annually and After Major Storm Events	Overflow		Overflow clogged	Capacity reduced by sediment or debris.	Remove sediment or debris/dispose.
As Needed Clean Orifice as Needed, At Least Biannually	Underdrain pipe		Prolonged surface ponding (see "Ponded water")	Plant roots, sediment or debris reducing capacity of underdrain.	Jet clean or rotary cut debris/roots from underdrain(s). If underdrains are equipped with a flow restrictor (e.g., orifice) to attenuate flows, the orifice must be cleaned regularly.

Recommended Frequency	Drainage System Feature	Date	Problem	Conditions to Check For	Maintenance Activities and Conditions that Should Exist
Biannually (Fall and Spring)	Facility bottom area and upland slope vegetation		Dead vegetation	Vegetation survival rate falls below 75% within first two years of establishment (unless project O&M manual or record drawing stipulates more or less than 75% survival rate).	<p>Determine cause of poor vegetation growth and correct condition. Replant as necessary to obtain 75% survival rate or greater. Refer to original planting plan, or approved jurisdictional species list for appropriate plant replacements (See Appendix 3 - Bioretention Plant List, in the LID Technical Guidance Manual for Puget Sound).</p> <p>Confirm that plant selection is appropriate for site growing conditions.</p> <p>Consultation with a landscape architect is recommended for removal, transplant, or substitution of plants.</p>

Recommended Frequency	Drainage System Feature	Date	Problem	Conditions to Check For	Maintenance Activities and Conditions that Should Exist
As needed	Vegetation (general)		Diseased Vegetation	Presence of diseased plants and plant material.	<p>Remove any diseased plants or plant parts and dispose of in an approved location (e.g., commercial landfill) to avoid risk of spreading the disease to other plants.</p> <p>Disinfect gardening tools after pruning to prevent the spread of disease.</p> <p>See Pacific Northwest Plant Disease Management Handbook for information on disease recognition and for additional resources.</p> <p>Replant as necessary according to recommendations provided for “facility bottom area and upland slope vegetation”.</p>
All Pruning Seasons	Trees and shrubs		Oversized trees and shrubs	Pruning as needed.	<p>Prune trees and shrubs in a manner appropriate for each species. Pruning should be performed by landscape professionals familiar with proper pruning techniques.</p> <p>All pruning of mature trees should be performed by or under the direct guidance of an ISA Certified Arborist.</p>
Annually	Trees and Shrubs		Oversized trees and shrubs	Large trees and shrubs interfere with operation of the facility or access for maintenance.	<p>Prune trees and shrubs using most current ANSI A300 standards and ISA BMPs.</p> <p>Remove trees and shrubs, if necessary.</p>

Recommended Frequency	Drainage System Feature	Date	Problem	Conditions to Check For	Maintenance Activities and Conditions that Should Exist
Biannually (Fall and Spring)	Trees and shrubs		Dead trees or shrubs	Standing dead vegetation is present.	<p>Remove standing dead vegetation.</p> <p>Replace dead vegetation within 30 days of reported dead and dying plants (as practical depending on weather/planting season).</p> <p>If vegetation replacement is not feasible within 30 days, and absence of vegetation may result in erosion problems, temporary erosion control measures should be put in place immediately.</p> <p>Determine cause of dead vegetation and address issue, if possible.</p> <p>If specific plants have a high mortality rate, assess the cause and replace with appropriate species. Consultation with a landscape architect is recommended.</p>

Recommended Frequency	Drainage System Feature	Date	Problem	Conditions to Check For	Maintenance Activities and Conditions that Should Exist
Biannually (Fall and Spring)	Trees and shrubs			Planting beneath mature trees.	<p>When working around and below mature trees, follow the most current ANSI A300 standards and ISA BMPs to the extent practicable (e.g., take care to minimize any damage to tree roots and avoid compaction of soil).</p> <p>Planting of small shrubs or groundcovers beneath mature trees may be desirable in some cases; such plantings should use mainly plants that come as bulbs, bare root or in 4-inch pots; plants should be in no larger than 1-gallon containers.</p>
Biannually (Fall and Spring)	Trees and shrubs		Tree support	Presence of or need for stakes and guys (tree growth, maturation, and support needs).	<p>Verify location of facility liners and underdrain (if any) prior to stake installation in order to prevent liner puncture or pipe damage.</p> <p>Monitor tree support systems: Repair and adjust as needed to provide support and prevent damage to tree.</p> <p>Remove tree supports (stakes, guys, etc.) after one growing season or maximum of 1 year.</p> <p>Backfill stake holes after removal.</p>

Recommended Frequency	Drainage System Feature	Date	Problem	Conditions to Check For	Maintenance Activities and Conditions that Should Exist
Annually	Trees and shrubs adjacent to vehicle travel areas (or areas where visibility needs to be maintained)		Line of sight	Vegetation causes some visibility (line of sight) or driver safety issues.	<p>Maintain appropriate height for sight clearance.</p> <p>Regular pruning (more than one time/ growing season) is required to maintain visual sight lines for safety or clearance along a walk or drive, consider relocating the plant to a more appropriate location.</p> <p>Remove or transplant if continual safety hazard.</p> <p>Consultation with a landscape architect is recommended for removal, transplant, or substitution of plants.</p>
Annually	Flower plants		Dead flowers	Dead or spent flowers present.	Remove spent flowers (deadhead).
Annually (Fall)	Perennials		Dead plants	Spent plants.	Cut back dying or dead and fallen foliage and stems.
Annually (Spring)	Emergent vegetation		Slow moving or ponded water	Vegetation compromises conveyance.	Hand rake sedges and rushes with a small rake or fingers to remove dead foliage before new growth emerges in spring or earlier only if the foliage is blocking water flow (sedges and rushes do not respond well to pruning).

Recommended Frequency	Drainage System Feature	Date	Problem	Conditions to Check For	Maintenance Activities and Conditions that Should Exist
Biannually (Winter and Spring)	Ornamental grasses (perennial)		Dead plant material	Dead material from previous year's growing cycle or dead collapsed foliage.	Leave dry foliage for winter interest. Hand rake with a small rake or fingers to remove dead foliage back to within several inches from the soil before new growth emerges in spring or earlier if the foliage collapses and is blocking water flow.
Biannually (Winter and Spring)	Ornamental grasses (evergreen)		Dead plant material	Dead growth present in spring.	Hand rake with a small rake or fingers to remove dead growth before new growth emerges in spring. Clean, rake, and comb grasses when they become too tall. Cut back to ground or thin every 2-3 years as needed.
Monthly (March - October, preceding seed dispersal)	Vegetation		Noxious weeds	Listed noxious vegetation is present (refer to current Pierce County Noxious Weed Control Board noxious weed list).	By law, class A & B noxious weeds must be removed, bagged and disposed as garbage immediately. Reasonable attempts must be made to remove and dispose of class C noxious weeds. It is strongly encouraged that herbicides and pesticides not be used in order to protect water quality; use of herbicides and pesticides may be prohibited in some jurisdictions. Apply mulch after weed removal (see "Mulch").



Recommended Frequency	Drainage System Feature	Date	Problem	Conditions to Check For	Maintenance Activities and Conditions that Should Exist
Monthly (March - October, preceding seed dispersal)	Vegetation		Weeds	Weeds are present.	Remove weeds with their roots manually with pincer-type weeding tools, flame weeders, or hot water weeders as appropriate. Follow IPM protocols for weed management.
Once in early to mid-May and once in early to mid-September	Vegetation		Excessive vegetation	Low-lying vegetation growing beyond facility edge onto sidewalks, paths, or street edge poses pedestrian safety hazard or may clog adjacent permeable pavement surfaces due to associated leaf litter, mulch, and soil.	Edge or trim groundcovers and shrubs at facility edge. Avoid mechanical blade-type edger and do not use edger or trimmer within 2 feet of tree trunks. While some clippings can be left in the facility to replenish organic material in the soil, excessive leaf litter can cause surface soil clogging.

Recommended Frequency	Drainage System Feature	Date	Problem	Conditions to Check For	Maintenance Activities and Conditions that Should Exist
As needed	Vegetation		Excessive vegetation	Excessive vegetation density inhibits stormwater flow beyond design ponding or becomes a hazard for pedestrian and vehicular circulation and safety.	<p>Determine whether pruning or other routine maintenance is adequate to maintain proper plant density and aesthetics.</p> <p>Determine if plant type should be replaced to avoid ongoing maintenance issues (an aggressive grower under perfect growing conditions should be transplanted to a location where it will not impact flow) .</p> <p>Remove plants that are weak, broken or not true to form; replace in-kind.</p> <p>Thin grass or plants impacting facility function without leaving visual holes or bare soil areas.</p> <p>Consultation with a landscape architect is recommended for removal, transplant, or substitution of plants.</p>
As needed	Vegetation		Excessive Vegetation	Vegetation blocking curb cuts, causing excessive sediment buildup and flow bypass.	Remove vegetation and sediment buildup.
Following weeding	Vegetation		Mulch	Bare spots (without mulch cover) are present or mulch depth less than 2 inches.	<p>Supplement mulch with hand tools to a depth of 2 to 3 inches.</p> <p>Replenish mulch per O&amp;M manual. Often coarse compost is used in the bottom of the facility and arborist wood chips are used on side slopes and rim (above typical water levels).</p> <p>Keep all mulch away from woody stems.</p>

Recommended Frequency	Drainage System Feature	Date	Problem	Conditions to Check For	Maintenance Activities and Conditions that Should Exist
Based on manufacturer instructions	Irrigation system (if any)		Plant Watering	Irrigation system present.	Follow manufacturer's instructions for O&M.
Annually	Irrigation system (if any)		Plant Watering	Sprinklers or drip irrigation not directed/ located to properly water plants.	Redirect sprinklers or move drip irrigation to desired areas.

Recommended Frequency	Drainage System Feature	Date	Problem	Conditions to Check For	Maintenance Activities and Conditions that Should Exist
Once every 1-2 weeks or as needed during prolonged dry periods	summer watering (first year)		Plant Watering	Trees, shrubs and ground cover in the first year of establishment period.	<p>10 to 15 gallons per tree.                      3 to 5 gallons per shrub.                      2 gallons water per square foot for groundcover areas.                      Water deeply, but infrequently, so that the top 6 to 12 inches of the root zone is moist.                      Use soaker hoses or spot water with a shower type wand when irrigation system is not present.</p> <ul style="list-style-type: none"> <li>• Pulse water to enhance soil absorption, when feasible.</li> <li>• Pre-moisten soil to break surface tension of dry or hydrophobic soils/mulch, followed by several more passes. With this method , each pass increases soil absorption and allows more water to infiltrate prior to runoff.</li> </ul> <p>Add a tree bag or slow-release watering device (e.g., bucket with a perforated bottom) for watering newly installed trees when irrigation system is not present.</p>

Recommended Frequency	Drainage System Feature	Date	Problem	Conditions to Check For	Maintenance Activities and Conditions that Should Exist
Once every 2 -4 weeks or as needed during prolonged dry periods	Summer watering (second and third years)		Plant Watering	Trees, shrubs and groundcovers in the second or third year of establishment period.	<p>10 to 15 gallons per tree.                      3 to 5 gallons per shrub.                      2 gallons water per square foot for groundcover areas.                      Water deeply, but infrequently, so that the top 6 to 12 inches of the root zone is moist.                      Use soaker hoses or spot water with a shower type wand when irrigation system is not present.</p> <ul style="list-style-type: none"> <li>• Pulse water to enhance soil absorption, when feasible.</li> <li>• Pre-moisten soil to break surface tension of dry or hydrophobic soils/mulch, followed by several more passes. With this method , each pass increases soil absorption and allows more water to infiltrate prior to runoff.</li> </ul>

Recommended Frequency	Drainage System Feature	Date	Problem	Conditions to Check For	Maintenance Activities and Conditions that Should Exist
As needed	Summer watering (after establishment)		Plant Watering	Established vegetation (after 3 years).	Plants are typically selected to be drought tolerant and not require regular watering after establishment; however, trees may take up to 5 years of watering to become fully established. Identify trigger mechanisms for drought-stress (e.g., leaf wilt, leaf senescence, etc.) of different species and water immediately after initial signs of stress appear. Water during drought conditions or more often if necessary to maintain plant cover.
Biannually and After Major Storm Events	Pest Control		Mosquitoes	Standing water remains for more than 3 days after the end of a storm.	Identify the cause of the standing water and take appropriate actions to address the problem (see "Ponded water"). To facilitate maintenance, manually remove standing water and direct to the storm drainage system (if runoff is from non pollution-generating surfaces) or sanitary sewer system (if runoff is from pollution-generating surfaces) after getting approval from sanitary sewer authority. Do not use pesticides or <i>Bacillus thuringiensis israelensis</i> (Bti).

Recommended Frequency	Drainage System Feature	Date	Problem	Conditions to Check For	Maintenance Activities and Conditions that Should Exist
As needed	Pest Control		Nuisance animals	Nuisance animals causing erosion, damaging plants, or depositing large volumes of feces.	Reduce site conditions that attract nuisance species where possible (e.g., plant shrubs and tall grasses to reduce open areas for geese, etc.). Place predator decoys. Follow IPM protocols for specific nuisance animal issues . Remove pet waste regularly. For public and right-of-way sites consider adding garbage cans with dog bags for picking up pet waste.
Every site visited associated with vegetation management	Pest Control		Insect pests	Signs of pests, such as wilting leaves, chewed leaves, and bark spotting or other indicators.	Reduce hiding places for pests by removing diseased and dead plants. For infestations, follow IPM protocols.

If you are unsure whether a problem exists, please contact Environmental Services at 253.591.5588.

Comments:

**#23 - Maintenance Checklist for Rain Gardens**

Recommended Frequency	Drainage System Feature	Date	Problem	Conditions to Check For	Maintenance Activities and Conditions that Should Exist
Biannually (During Wet Season)	Earthen side slopes and berms		Failure in earthen reservoir	Persistent soil erosion on slopes.	If erosion persists, water may be flowing into the garden too rapidly. In this case, the slope of the pipe or swale directing water to the garden, or the amount of water may need to be reduced (see "Erosion control at inlet").
Annually	Rockery sidewalls		Failure in sidewalls	Rockery sidewalls are insecure.	Stabilize rockery sidewalls (may require consultation with engineer particularly for walls 4 feet or greater in height).
Biannually	Rain Garden Footprint		Accumulation of sediment or debris	Trash and debris present.	Clean out trash and debris.
Annually	Facility bottom area		Accumulation of sediment or debris	Visible sediment deposition in the rain garden that reduces drawdown time of water in the rain garden.	Remove sediment accumulation. If sediment is deposited from water entering the rain garden, determine the source and stabilize the area or provide pretreatment.
As Needed, During and After Fall Leaf Drop	Facility Bottom Area		Accumulation of leaves	Accumulated leaves in rain garden may reduce infiltration capacity of rain garden or clog overflow.	Remove Leaves.



Recommended Frequency	Drainage System Feature	Date	Problem	Conditions to Check For	Maintenance Activities and Conditions that Should Exist
Biannually and After Major Storm Events	Ponded Water		Water remains in bioretention facility 3 days after storm event	Excessive ponding water. Ponded water remains in the basin more than 3 days after the end of a storm.	<p>Confirm leaf, debris or sediment buildup in the bottom of the rain garden is not impeding infiltration. If necessary, remove leaf litter/debris/sediment. If this does not solve the problem, consultation with a professional with rain garden expertise is recommended to evaluate the following:</p> <ul style="list-style-type: none"> <li>• Check for other water inputs (e.g., groundwater, illicit connections).</li> <li>• Verify that the facility is sized appropriately for the contributing area. Confirm that the contributing area has not increased.</li> <li>• Determine if the soil is clogged by sediment accumulation at the surface or if the soil has become overly compacted.</li> </ul>
Annually	Splash Block Inlet		Inlet Failure	Water is not being directed properly to the rain garden and away from the building.	Reconfigure/repair splash blocks to direct water to the rain garden and away from the building.

Recommended Frequency	Drainage System Feature	Date	Problem	Conditions to Check For	Maintenance Activities and Conditions that Should Exist
Annually	Pipe inlet/outlet		Inlet Pipe Structure Failure	Damaged/cracked pipes.	Repair/seal cracks. Replace when repair is insufficient.
Annually	Pipe inlet/outlet		Inlet Pipe Clogged	Pipe capacity is reduced by sediment or debris (can cause backups and flooding).	Clear pipes of sediment and debris.
Annually	Erosion control at inlet		Excessive Sedimentation	Rock or cobble is removed or missing and concentrated flows are contacting soil.	Maintain a cover of rock or cobbles to protect the ground where concentrated water flows into the rain garden from a pipe or swale.
As needed	Vegetation		Diseased Vegetation	Dying, dead, or unhealthy plants.	Maintain a healthy cover of plants. Remove any diseased plants or plant parts and dispose of in commercial landfill to avoid risk of spreading the disease to other plants. Disinfect gardening tools after pruning to prevent the spread of disease. Re-stake trees if they need more support, but plan to remove stakes and ties after the first year. Cars can damage roots – protect root areas of trees and plants from vehicle traffic.
As needed	Vegetation		Line of Sight	Vegetation inhibits sight distances and sidewalks.	Keep sidewalks and sight distances on roadways clear.
As needed	Vegetation		Dead Vegetation	Broken, dead, or sucker vegetation is present.	Remove broken or dead branches and suckers.
As needed	Vegetation		Localized Ponding or Obstruction of flow	Vegetation is crowding inlets and outlets.	Keep water inlets and outlines in the rain garden clear or vegetation.

Recommended Frequency	Drainage System Feature	Date	Problem	Conditions to Check For	Maintenance Activities and Conditions that Should Exist
One time March through June	Vegetation		Dead/diseased plants	Yellowing: possible Nitrogen (N) deficiency. Poor growth: possible Phosphorous (P) deficiency. Poor flowering, spotting or curled leaves, or weak roots or stems: possible Potassium (K) deficiency.	Test soil to identify specific nutrient deficiencies. Consult with a professional knowledgeable in the area of natural amendments or refer to Natural Lawn and Garden Care resources and avoid synthetic fertilizers. Consider selecting different plants for soil conditions.
As needed, Preceding seed dispersal	Vegetation		Weeds Present	Problem weeds are present.	Remove weeds by hand, especially in spring when the soil is moist and the weeds are small. Dig or pull weeds out by the roots before they go to seed. Apply mulch after weeding (see "Mulch").
Monthly March - October, preceding seed dispersal	Vegetation		Noxious Weeds	Listed noxious vegetation is present (refer to current Pierce County Noxious Weed Control Board noxious weed list).	By law, class A & B noxious weeds must be removed, bagged and disposed as garbage immediately. Reasonable attempts must be made to remove and dispose of class C noxious weeds. It is strongly encouraged that herbicides not be used in order to protect water quality; use of herbicides may be prohibited in some jurisdictions. Apply mulch after weed removal (see "Mulch").

Recommended Frequency	Drainage System Feature	Date	Problem	Conditions to Check For	Maintenance Activities and Conditions that Should Exist
Following weeding	Vegetation		Mulch	Bare spots (without mulch cover) are present or mulch depth less than 2 inches.	Supplement mulch, using hand tools, to a depth of 2 to 3 inches. Use coarse compost in the bottom of the rain garden and arborist wood chips on side slopes and rim (above typical water levels). Keep all mulch from being in contact with woody stems.
Once every 1-2 weeks or as needed during prolong dry periods	Summer watering (first year)		Plant Watering	Tree, shrubs and groundcovers in first year of establishment.	10 to 15 gallons per tree. 3 to 5 gallons per shrub. 2 gallons water per square foot for groundcover areas. Water deeply, but infrequently, so that the top 6 to 12 inches of the root zone is moist. Use soaker hoses or spot water with a shower type wand when irrigation system is not present. Add a tree bag or slow-release watering device (e.g., bucket with a perforated bottom) for watering newly installed trees when irrigation system is not present.

Recommended Frequency	Drainage System Feature	Date	Problem	Conditions to Check For	Maintenance Activities and Conditions that Should Exist
Once every 2-4 weeks or as needed during prolonged dry periods	Summer watering (second and third years)		Plant Watering	Tree shrubs and groundcovers in the second or third year of establishment.	10 to 15 gallons per tree. 3 to 5 gallons per shrub. 2 gallons water per square foot for groundcover areas. Water deeply, but infrequently, so that the top 6 to 12 inches of the root zone is moist. Use soaker hoses or spot water with a shower type wand when irrigation system is not present.
As needed	Summer watering (after establishment)		Plant Watering	Established vegetation (after 3 years).	Water during drought conditions or more often if necessary to maintain plant cover. Identify trigger mechanisms for drought-stress (e.g., leaf wilt, leaf senescence, etc.) of different rain garden species and water immediately after initial signs of stress appear.
Biannually and After Major Storm Events	Pest Control		Mosquitoes	Standing water remains for more than 3 days after the end of a storm.	Identify the cause of the standing water and take appropriate actions to address the problem (see "Ponded water"). Do not use pesticides or <i>Bacillus thuringiensis israelensis</i> (Bti).

If you are unsure whether a problem exists, please contact Environmental Services at 253.591.5588.

Comments:

**#24 - Maintenance Checklist for Cisterns**

Recommended Frequency	Drainage System Feature	Date	Problem	Conditions to Check For	Maintenance Activities and Conditions that Should Exist
Biannually (Spring & Fall)	Roof		Low flow into cistern or excessive overflow	Debris has accumulated.	Remove debris.
Biannually (Spring & Fall)	Gutter		Low flow into cistern or excessive overflow	Debris has accumulated.	Clean gutters (the most critical cleaning is in mid- to late-spring to flush the pollen deposits from surrounding trees).
Annually (preferably Sept.)	Screens		Excessive sediment accumulation in cistern	Screen has deteriorated.	Replace.
Monthly from Oct. – Apr.	Screens		Low flow into cistern or excessive overflow	Accumulation of material on screen.	Clear screen of any accumulated debris.
Monthly from Oct. – Apr.	Low Flow Orifice		Low or no flow out of cistern.	Material clogging orifice.	Clean low flow orifice.
Biannually (Spring & Fall)	Overflow pipe		Low or no flow out of cistern.	Pipe is damaged.	Repair/replace.
Biannually (Spring & Fall)	Overflow pipe		Low or no flow out of cistern.	Pipe is clogged.	Remove debris.
Annually (preferably Sept.)	Cistern		Excess overflow	Debris has accumulated at bottom of tank.	Remove debris.
At startup	Training and Documentation		Training / written guidance	Training / written guidance is required for proper O&M.	Provide property owners and tenants with proper training and a copy of the O&M manual.
Ongoing	Safety		Access and Safety	Access to cistern required for maintenance or cleaning.	Any cistern detention system opening that could allow the entry of people must be marked: "DANGER—CONFINED SPACE".
Ongoing	Cistern		Leaking Cistern	Excess water around cistern. Damage to cistern.	Disconnect inlets. Contact design engineer.

Recommended Frequency	Drainage System Feature	Date	Problem	Conditions to Check For	Maintenance Activities and Conditions that Should Exist
Annually (preferably Sept.)	General		Insects	When insects such as wasps and hornets interfere with maintenance activities.	Insects destroyed or removed from site. Apply insecticides in compliance with adopted integrated pest management policies.

If you are unsure whether a problem exists, please contact Environmental Services at 253.591.5588.

Comments:

**#25 - Maintenance Checklist for Compost Amended Soil**

Recommended Frequency	Drainage System Feature	Date	Problem	Conditions to Check For	Maintenance Activities and Conditions that Should Exist
Annually	Soil Media (maintain high organic soil content)		Potential Erosion	Vegetation not fully covering ground surface or vegetation health is poor.	Maintain 2 to 3 inches of mulch over bare areas in landscape beds. Add plants if sufficient space. Re-seed bare turf areas until the vegetation fully covers ground surface.
Ongoing	Soil media (maintain high organic soil content)		Routine Maintenance	None. (routine maintenance)	Return leaf fall and shredded woody materials from the landscape to the site when possible in order to replenish soil nutrients and structure.
Ongoing	Soil media (maintain high organic soil content)		Routine Maintenance	None. (routine maintenance)	On turf areas, "grasscycle" (mulch-mow or leave the clippings) to improve turf health.
Ongoing	Soil media (maintain high organic soil content)		Routine Maintenance	None. (routine maintenance)	Avoid use of pesticides (bug and weed killers) and herbicides, like "weed & feed", which damage the soil.
Annually	Soil media (maintain high organic soil content)		Routine Maintenance	None. (routine maintenance)	Where fertilization is needed (mainly turf and annual flower beds), a moderate fertilization program should be used which relies on compost, natural fertilizers or slow-release synthetic balanced fertilizers. Follow IPM protocols for fertilization procedures.



Recommended Frequency	Drainage System Feature	Date	Problem	Conditions to Check For	Maintenance Activities and Conditions that Should Exist
Annually (inspect during storm event)	Soil media (maintain infiltration)		Wet Soils Ponding	Soils become waterlogged, do not appear to be infiltrating.	<p>To remediate compaction, aerate soil, till to at least 8-inch depth, or further amend soil with compost and re-till.</p> <p>If areas are turf, aerate compacted areas and topdress them with 1/4 to 1/2 inch of compost to renovate them.</p> <p>If drainage is still slow, consider investigating alternative causes (e.g., high wet season groundwater levels, low permeability soils).</p> <p>Also consider site use and protection from compacting activities.</p>
Annually (at least once during the wet season) and after major storm events)	Erosion/ Scouring		Visible Erosion	Areas of potential erosion are visible.	<p>Identify and address cause of erosion (e.g., concentrated flow entering area, channelization of runoff) and stabilize damaged area (regrade, rock, vegetation, erosion control matting).</p> <p>For deep channels or cuts (over 3 inches in ponding depth), temporary erosion control measures should be put in place until permanent repairs can be made.</p>
Annually	Grass/ vegetation		Unhealthy Vegetation	Less than 75% of planted vegetation is healthy with a generally good appearance.	<p>Take appropriate maintenance actions (e.g., remove/replace plants).</p> <p>If problem persists, evaluate if vegetation is appropriate for the location (e.g., exposure, soil, soil moisture).</p>

Recommended Frequency	Drainage System Feature	Date	Problem	Conditions to Check For	Maintenance Activities and Conditions that Should Exist
Monthly (March - October, preceding seed dispersal)	Vegetation		Noxious weeds	Listed noxious vegetation is present (refer to current Pierce County Noxious Weed Control Board noxious weed list).	By law, class A & B noxious weeds must be removed, bagged and disposed as garbage immediately. Reasonable attempts must be made to remove and dispose of class C noxious weeds. Watch for and respond to new occurrences of especially aggressive weeds such as Himalayan blackberry, Japanese knotweed, morning glory, English ivy, and reed canary grass to avoid invasions. It is strongly encouraged that herbicides and pesticides not be used in order to protect water quality; use of herbicides and pesticides may be prohibited in some jurisdictions.
Monthly (March - October, preceding seed dispersal)	Vegetation		Weeds	Weeds are present.	Remove weeds with their roots manually with pincer-type weeding tools, flame weeders, or hot water weeders as appropriate. Follow IPM protocols for weed management.

If you are unsure whether a problem exists, please contact Environmental Services at 253.591.5588.

Comments:

**#26 - Maintenance Checklist for Vegetated Roof**

Recommended Frequency	Drainage System Feature	Date	Problem	Conditions to Check For	Maintenance Activities and Conditions that Should Exist
Annually (Inspect During Rain Event)	Growth Medium		Ponding or slow infiltration	Water does not permeate growth media (runs off soil surface) or crusting is observed.	Aerate (e.g., rake) or replace medium taking care not to damage the waterproof membrane.
Annually	Growth Medium		Thin growth medium	Growth medium thickness is less than design thickness (due to erosion and plant uptake).	Supplement growth medium to design thickness.
Biannually (at least once during wet season)	Growth Medium		Leaf/Debris Buildup	Fallen leaves or debris are present.	Remove/dispose of debris and fallen leaves.
Annually (at least once during the wet season and after major storm events)	Growth Medium		Erosion and sedimentation	Growth media erosion/scour is visible (e.g., gullies).	Take steps to repair or prevent erosion. Fill, hand tamp, or lightly compact, and stabilize with additional soil substrate/growth medium (similar in nature to the original material) and additional plants.
Biannually (inspect during plant establishment)	Erosion Control Measures		Erosion	Mat or other erosion control is damaged or depleted during plant establishment period.	Repair/replace erosion control measures until 90% vegetation coverage attained. Avoid application of mulch on extensive vegetated roofs.
Biannually and after major storm events	Roof Drain		Water Flow Issues	Sediment, vegetation, or debris reducing capacity of inlet structure.	Clear blockage. Identify and correct any problems that led to blockage.
Annually	Roof Drain		Water Flow Issues	Pipe is clogged.	Remove roots or debris.
Annually	Roof Drain		Damaged roof drain	Inlet pipe is in poor condition.	Repair/replace.
Annually	Border Zone		Aesthetics	Vegetation is encroaching into border zone aggregate.	Remove and dispose of weeds and transplant desirable vegetation to growth medium area.

Recommended Frequency	Drainage System Feature	Date	Problem	Conditions to Check For	Maintenance Activities and Conditions that Should Exist
Annually	Flashing, gravel, stops, utilities, or other structures on roof		Deteriorating roof components	Flashing, utilities or other structures on roof are deteriorating (can serve as source of metal pollution in vegetated roof runoff).	Repair (e.g., recoat) or replace to eliminate potential pollutant source. Note that any work done around flashings and drains should be done with care to protect the waterproof membrane.
Biannually	Access and Safety		Access Concerns	Insufficient egress/ingress routes and fall protection.	Maintain egress and ingress routes to design standards and fire codes. Ensure appropriate fall protection.
Biannually	Vegetation		Plant Coverage	Vegetative coverage falls below 90% (unless design specifications stipulate less than 90% coverage).	Plant bare areas with vegetation. If necessary, install erosion control measures until percent coverage goal is attained.
Annually (first 2 years in spring, as needed thereafter)	Vegetation		Sedum Coverage	Extensive roof with low density sedum population.	Mulch mow sedums-creating cuttings from existing plants to encourage colonization.
Biannually (Fall and Spring)	Dead Plants		Dead Vegetation	Dead vegetation is present.	Normally dead plant material can be recycled on the roof; however, specific plants or aesthetic considerations may warrant removing and replacing dead material (see manufacturer's recommendations).
All pruning seasons (timing varies by species)	Trees and shrubs - intensive vegetated roof		Plants Overgrown	Pruning as needed.	All pruning of mature trees should be performed by or under the direct guidance of an ISA Certified Arborist.

Recommended Frequency	Drainage System Feature	Date	Problem	Conditions to Check For	Maintenance Activities and Conditions that Should Exist
Annually	Vegetation - extensive vegetated roof		Fertilization	Poor plant establishment and possible nutrient deficiency in growth medium.	<p>Allow organic debris to replenish and maintain long-term nutrient balance and growth medium structure.</p> <p>Conduct annual soil test 2-3 weeks prior to the spring growth flush to assess need for fertilizer. Utilize test results to adjust fertilizer type and quantity appropriately.</p> <p>Apply minimum amount slow-release fertilizer necessary to achieve successful plant establishment.</p> <p>Apply fertilizer only after acquiring required approval from facility owner and operator.</p> <p>Note that extensive vegetated roofs are designed to require zero to minimal fertilization after establishment (excess fertilization can contribute to nutrient export).</p>

Recommended Frequency	Drainage System Feature	Date	Problem	Conditions to Check For	Maintenance Activities and Conditions that Should Exist
Annually	Vegetation		Fertilization - intensive vegetated roof	Fertilization may be necessary during establishment period or for plant health and survivability after establishment.	Conduct annual soil test 2-3 weeks prior to the spring growth flush to assess need for fertilizer. Utilize test results to adjust fertilizer type and quantity appropriately. Apply minimum amount slow-release fertilizer necessary to achieve successful plant establishment. Apply fertilizer only after acquiring required approval from facility owner and operator. Intensive vegetated roofs may require more fertilization than extensive vegetated roofs.
Monthly (March-October) Preceding Seed Dispersal	Vegetation		Weeds	Weeds are present.	Remove weeds with their roots manually with pincer-type weeding tools or hot water weeders as appropriate. Follow IPM protocols for weed management.

Recommended Frequency	Drainage System Feature	Date	Problem	Conditions to Check For	Maintenance Activities and Conditions that Should Exist
Monthly (March-October Preceding Seed Dispersal)	Vegetation - intensive vegetated roof		Noxious Weeds	Listed Noxious vegetation is present (refer to the Pierce County Noxious Control Board noxious weed list).	By law, class A & B noxious weeds must be removed, bagged and disposed as garbage immediately. Reasonable attempts must be made to remove and dispose of class C noxious weeds. It is strongly encouraged that herbicides and pesticides not be used in order to protect water quality; use of herbicides and pesticides may be prohibited in some jurisdictions.
Based on manufacturer's Instructions	Irrigation System (if any)		Irrigation	Irrigation system present and functioning.	Follow manufacturer's instructions for operation and maintenance.
Once every 1-2 weeks as needed during prolonged dry periods	Summer watering - extensive vegetated roof		Watering	Vegetation in establishment period (1-2 years).	Water weekly during periods of no rain to ensure establishment (30 to 50 gallons per 100 square feet).
Once every 1-2 weeks as needed during prolonged dry periods	Summer watering - intensive vegetated roof		Watering	Vegetation in establishment period (1-2 years).	Water deeply, but infrequently, so that the top 6 to 12 inches of the root zone is moist. Use soaker hoses or spot water with a shower type wand when irrigation system not present.
As needed	Summer watering - intensive vegetated roof		Watering	Established vegetation (after 2 years).	Water during drought conditions or more often if necessary to maintain plant cover.

Recommended Frequency	Drainage System Feature	Date	Problem	Conditions to Check For	Maintenance Activities and Conditions that Should Exist
Biannually and After Major Storm Events	Pests		Mosquito	Standing water remains for more than 3 days after the end of a storm.	Identify the cause of the standing water and take appropriate actions to address the problem (e.g., aerate or replace medium, unplug drainage). Manually remove standing water and direct to storm drainage system. Do not use pesticides or <i>Bacillus thuringiensis israelensis</i> (Bti).
As Needed	Pests		Nuisance Animals	Nuisance animals causing erosion, damaging plants, or depositing large volumes of feces.	Reduce site conditions that attract nuisance species. Place predator decoys. Follow IPM protocols for specific nuisance animal issues.

If you are unsure whether a problem exists, please contact Environmental Services at 253.591.5588.

Comments:



**#27 - Maintenance Checklist for Pervious Pavement**

Recommended Frequency	Drainage System Feature	Date	Problem	Conditions to Check For	Maintenance Activities and Conditions that Should Exist
Annually and After Major Storm Events	Permeable Pavements , All		Excessive Sedimentation	Runon from adjacent areas deposits soil, mulch or sediment on paving.	Clean deposited soil or other materials. Check if surface elevation of adjacent planted area is too high, or slopes towards pavement, and can be regraded (prior to regrading, protect permeable pavement by covering with temporary plastic and secure covering in place). Mulch and/or plant all exposed soils that may erode to pavement surface.

Recommended Frequency	Drainage System Feature	Date	Problem	Conditions to Check For	Maintenance Activities and Conditions that Should Exist
Annually or Biannually	Porous asphalt or pervious concrete		Routine Maintenance	None (routine maintenance)	<p>Clean surface debris from pavement surface using one or a combination of the following methods:                      Remove sediment, debris, trash, vegetation, and other debris deposited onto pavement (rakes and leaf blowers can be used for removing leaves).                      Vacuum/sweep permeable paving installation using:</p> <ul style="list-style-type: none"> <li>• Walk-behind vacuum (sidewalks)</li> <li>• High efficiency regenerative air or vacuum sweeper (roadways, parking lots)</li> <li>• ShopVac or brush brooms (small areas)</li> <li>• Hand held pressure washer or power washer with rotating brushes</li> </ul> <p>Follow equipment manufacturer guidelines for determining when equipment is most effective for cleaning permeable pavement. Dry weather is more effective for some equipment.</p>

Recommended Frequency	Drainage System Feature	Date	Problem	Conditions to Check For	Maintenance Activities and Conditions that Should Exist
Annually (inspect during rain event)	Porous asphalt or pervious concrete		Ponding on surface or water flows off the permeable pavement surface during a rain event (does not infiltrate)	Surface is clogged.	<p>Review the overall performance of the facility (note that small clogged areas may not reduce overall performance of facility). Test the surface infiltration rate using ASTM C1701 as a corrective maintenance indicator. Perform one test per installation, up to 2,500 square feet. Perform an additional test for each additional 2,500 square feet up to 15,000 square feet total. Above 15,000 square feet, add one test for every 10,000 square feet.</p> <p>If the results indicate an infiltration rate of 10 inches per hour or less, then perform corrective maintenance to restore permeability.</p> <p>To clean clogged pavement surfaces, use one or combination of the following methods:</p> <ul style="list-style-type: none"> <li>• Combined pressure wash and vacuum system calibrated to not dislodge wearing course aggregate. Hand held pressure washer or power washer with rotating brushes.</li> <li>• Pure vacuum sweepers.</li> </ul>

Recommended Frequency	Drainage System Feature	Date	Problem	Conditions to Check For	Maintenance Activities and Conditions that Should Exist
Annually	Porous asphalt or pervious concrete		Sedimentation	Sediment present at the surface of the pavement.	Assess the overall performance of the pavement system during a rain event. If water runs off the pavement and/or there is ponding then see above. Determine source of sediment loading and evaluate whether or not the source can be reduced/eliminated. If the source cannot be addressed, consider increasing frequency of routine cleaning (e.g., twice per year instead of once per year).
Annually (Summer)	Porous Asphalt or pervious concrete		Moss Growth	Moss growth inhibits infiltration or poses slip/safety hazard.	Sidewalks: Use a stiff broom to remove moss in the summer when it is dry. Parking lots and roadways: Pressure wash, vacuum sweep, or use a combination of the two for cleaning moss from pavement surface. May require stiff broom or power brush in areas of heavy moss.
Annually	Porous Asphalt or pervious concrete		Damaged Pavement	Major cracks or trip hazards and concrete spalling and raveling.	Fill potholes or small cracks with patching mixes. Large cracks and settlement may require cutting and replacing the pavement section. Replace in-kind where feasible. Replacing porous asphalt with conventional asphalt is acceptable if it is a small percentage of the total facility area and does not impact the overall facility function. Take appropriate precautions during pavement repair and replacement efforts to prevent clogging of adjacent porous materials.

Recommended Frequency	Drainage System Feature	Date	Problem	Conditions to Check For	Maintenance Activities and Conditions that Should Exist
Annually or Biannually	Interlocking concrete paver blocks and aggregate pavers		Routine Maintenance	None (routine maintenance)	<p>Clean pavement surface using one or a combination of the following methods:                      Remove sediment, debris, trash, vegetation, and other debris deposited onto pavement (rakes and leaf blowers can be used for removing leaves).                      Vacuum/sweep permeable paving installation using:</p> <ul style="list-style-type: none"> <li>• Walk-behind vacuum (sidewalks)</li> <li>• High efficiency regenerative air or vacuum sweeper (roadways, parking lots)</li> <li>• ShopVac or brush brooms (small areas)</li> </ul> <p>Note: Vacuum settings may have to be adjusted to prevent excess uptake of aggregate from paver openings or joints. Vacuum surface openings in dry weather to remove dry, encrusted sediment.</p>

Recommended Frequency	Drainage System Feature	Date	Problem	Conditions to Check For	Maintenance Activities and Conditions that Should Exist
Annually (inspect during rain event)	Interlocking concrete paver blocks and aggregate pavers		Ponding on surface or water flows off the permeable pavement surface during a rain event (does not infiltrate).	Surface is clogged.	<p>Review the overall performance of the facility (note that small clogged areas may not reduce overall performance of facility). Test the surface infiltration rate using ASTM C1701 as a corrective maintenance indicator. Perform one test per installation, up to 2,500 square feet. Perform an additional test for each additional 2,500 square feet up to 15,000 square feet total. Above 15,000 square feet, add one test for every 10,000 square feet.</p> <p>If the results indicate an infiltration rate of 10 inches per hour or less, then perform corrective maintenance to restore permeability.</p> <p>Clogging is usually an issue in the upper 2 to 3 centimeters of aggregate. Remove the upper layer of encrusted sediment, and fines, and/or vegetation from openings and joints between the pavers by mechanical means and/or suction equipment (e.g., pure vacuum sweeper).</p> <p>Replace aggregate in paver cells, joints, or openings per manufacturer's recommendations.</p>

Recommended Frequency	Drainage System Feature	Date	Problem	Conditions to Check For	Maintenance Activities and Conditions that Should Exist
Annually	Interlocking concrete paver blocks and aggregate pavers		Sedimentation	Sediment present at the surface of the pavement.	Assess the overall performance of the pavement system during a rain event. If water runs off the pavement and/or there is ponding, then see above. Determine source of sediment loading and evaluate whether or not the source can be reduced/eliminated. If the source cannot be addressed, consider increasing frequency of routine cleaning (e.g., twice per year instead of once per year).
Annually	Interlocking concrete paver blocks and aggregate pavers		Moss Growth	Moss growth inhibits infiltration or poses slip/safety hazard.	Sidewalks: Use a stiff broom to remove moss in the summer when it is dry. Parking lots and roadways: Vacuum sweep or stiff broom/power brush for cleaning moss from pavement surface.
Annually	Interlocking concrete paver blocks and aggregate pavers		Damaged Surface	Paver block missing or damaged.	Remove individual damaged paver blocks by hand and replace or repair per manufacturer's recommendations.
Annually	Interlocking Concrete paver blocks and aggregate pavers		Damaged Surface	Loss of aggregate material between paver blocks.	Refill per manufacturer's recommendations for interlocking paver sections.
Annually	Interlocking concrete paver blocks and aggregate pavers		Damaged Surface	Settlement of surface.	May require resetting.
Annually or Biannually	Open-celled paving grid with gravel		Routine Maintenance	None (routine maintenance).	Remove sediment, debris, trash, vegetation, and other debris deposited onto pavement (rakes and leaf blowers can be used for removing leaves). Follow equipment manufacturer guidelines for cleaning surface.

Recommended Frequency	Drainage System Feature	Date	Problem	Conditions to Check For	Maintenance Activities and Conditions that Should Exist
Annually (inspect during rain event)	Open-celled paving grid with gravel		Ponding on surface or water flows off the permeable pavement surface during a rain event (does not infiltrate)	Aggregate is clogged.	Use vacuum truck to remove and replace top course aggregate. Replace aggregate in paving grid per manufacturer's recommendations.
Annually	Open-celled paving grid with gravel		Damaged Surface	Paving grid missing or damaged.	Remove pins, pry up grid segments, and replace gravel. Replace grid segments where three or more adjacent rings are broken or damaged. Follow manufacturer guidelines for repairing surface.
Annually	Open-celled paving grid with gravel		Damaged Surface	Settlement of surface.	May require resetting.
Annually	Open-celled paving grid with gravel		Damaged Surface	Loss of aggregate material in paving grid.	Replenish aggregate material by spreading gravel with a rake (gravel level should be maintained at the same level as the plastic rings or no more than 1/4 inch above the top of rings). See manufacturer's recommendations.
Annually	Open-celled paving grid with gravel		Weeds	Weeds present.	Manually remove weeds. Presence of weeds may indicate that too many fines are present (refer to Actions Needed under "Aggregate is clogged" to address this issue).
Annually or Biannually	Open-celled paving grid with grass		Routine Maintenance	None (routine maintenance).	Remove sediment, debris, trash, vegetation, and other debris deposited onto pavement (rakes and leaf blowers can be used for removing leaves). Follow equipment manufacturer guidelines for cleaning surface.



Recommended Frequency	Drainage System Feature	Date	Problem	Conditions to Check For	Maintenance Activities and Conditions that Should Exist
Annually (inspect during rain event)	Open-celled paving grid with grass		Ponding on surface or water flows off the permeable pavement surface during a rain event (does not infiltrate)	Aggregate is clogged.	Rehabilitate per manufacturer's recommendations.
Annually	Open-celled paving grid with grass		Damaged Surface	Paving grid missing or damaged.	Remove pins, pry up grid segments, and replace grass. Replace grid segments where three or more adjacent rings are broken or damaged. Follow manufacturer guidelines for repairing surface.
Annually	Open-celled paving grid with grass		Damaged Surface	Settlement of surface.	May require resetting.
Annually	Open-celled paving grid with grass		Aesthetics, erosion potential	Poor grass coverage in paving grid.	Restore growing medium, reseed or plant, aerate, and/or amend vegetated area as needed. Traffic loading may be inhibiting grass growth; reconsider traffic loading if feasible.
As Needed	Open-celled paving grid with grass		Routine Maintenance	None (routine maintenance).	Use a mulch mower to mow grass.
Annually	Open-celled paving grid with grass		Routine Maintenance	None (routine maintenance).	Sprinkle a thin layer of compost on top of grass surface (1/2" top dressing) and sweep it in. Do not use fertilizer.
Annually	Open-celled paving grid with grass		Weeds	Weeds present.	Manually remove weeds. Mow, torch, or inoculate and replace with preferred vegetation.
Annually	Inlet/outlet pipe		Water Flow	Pipe is damaged.	Repair/replace.
Annually	Inlet/outlet pipe		Water Flow	Pipe is clogged.	Remove roots or debris.

Recommended Frequency	Drainage System Feature	Date	Problem	Conditions to Check For	Maintenance Activities and Conditions that Should Exist
As needed, clean orifice at least biannually	Underdrain pipe		Water Flow	Plant roots, sediment, or debris is reducing capacity of underdrain (may cause prolonged drawdown period).	Jet clean or rotary cut debris/ roots from underdrain(s). If underdrains are equipped with a flow restrictor (e.g., orifice) to attenuate flows, the orifice must be cleaned regularly.
As needed, clean orifice at least biannually	Raised subsurface overflow pipe		Water Flow	Plant roots, sediment, or debris is reducing capacity of underdrain.	Jet clean or rotary cut debris/ roots from under-drain(s). If underdrains are equipped with a flow restrictor (e.g., orifice) to attenuate flows, the orifice must be cleaned regularly.
Annually and After Major Storm Events	Outlet structure		Water Flow	Sediment vegetation, or debris reducing capacity of outlet structure.	Clear the blockage. Identify the source of the blockage and take actions to prevent future blockages.
Biannually	Overflow		Erosion Potential	Native soil is exposed or other signs of erosion damage are present at discharge point.	Repair erosion and stabilize surface.
Annually and After Major Storm Events	Observation port		Water ponding or infiltrating slowly	Water remains in the storage aggregate longer than anticipated by design after the end of the storm.	If immediate cause of extended ponding is not identified, schedule investigation of subsurface materials or other potential causes of system failure.
As needed	Adjacent large shrubs or trees		Water ponding or infiltrating slowly	Vegetation related fallout clogs or will potentially clog voids.	Sweep leaf litter and sediment to prevent surface clogging and ponding. Prevent large root systems from damaging subsurface structural components.
Once in May and Once in September	Adjacent large shrubs or trees		Aesthetics	Vegetation growing beyond facility edge onto sidewalks, paths and street edge.	Edging and trimming of planted areas to control groundcovers and shrubs from overreaching the sidewalks, paths and street edge improves appearance and reduces clogging of permeable pavements by leaf litter, mulch and soil.

Recommended Frequency	Drainage System Feature	Date	Problem	Conditions to Check For	Maintenance Activities and Conditions that Should Exist
In fall (October to December) after leaf drop (1-3 times, depending on canopy cover)	Leaves, needles, and organic debris		Clog Potential	Accumulation of organic debris and leaf litter.	Use leaf blower or vacuum to blow or remove leaves, evergreen needles, and debris (i.e., flowers, blossoms) off of and away from permeable pavement.

If you are unsure whether a problem exists, please contact Environmental Services at 253.591.5588.

Comments:

**#28 - Maintenance Checklist for Ballasted Sidewalk**

Recommended Frequency	Drainage System Feature	Date	Problem	Conditions to Check For	Maintenance Activities and Conditions that Should Exist
Biannually (Fall and Spring)	Trench Surface		Water Not Reaching Facility	Accumulated Trash, debris, or sediment on surface that impedes sheet flow into facility.	Remove/dispose in accordance with local solid waste requirements.
Annually and After Major Storm Events	Trench Surface		Excessive Sedimentation	Runon from adjacent areas deposits soil, mulch or sediment on trench surface.	Clean deposited soil or other materials. Check if surface elevation of adjacent planted areas is too high or slopes toward pavement and can be regraded. Mulch and/or plant exposed soils.
Biannually (Fall and Spring)	Trench Surface/ Surrounding Soils		Ponding or Soggy Areas	Inspect to see if water is ponding at surface during storm events.	Remove and replace clogged ballast.
Annually	Sidewalk Pavement		Ponding or Erosion of Adjacent Surfaces	Uneven surfaces or potholes that prohibit sheet flow into trench entrance.	Remove and replace sidewalk panel and possible regrade or replace permeable ballast.

**#29 - Proprietary Stormwater Devices (Emerging Technologies)**

At a minimum all stormwater devices must be inspected every six months and after every major storm event. Use the manufacturer's recommendations as tailored to the use of the site and as outlined in the Operation and Maintenance Manual. Operations and Maintenance shall conform to any Ecology issued use level designation as applicable.

If you are unsure whether a problem exists, please contact Environmental Services at 253.591.5588.

Comments:

**#30 - General Maintenance Concerns for Stormwater Facilities**

Recommended Frequency	Drainage System Feature	Date	Problem	Conditions to Check For	Maintenance Activities and Conditions that Should Exist
Based on manufacturers instructions	Irrigation		Irrigation system (if any)	Irrigation system present.	Follow manufacturer's instructions for O&M.
Weekly (May – September)	Irrigation		Plant watering	Plant establishment period (1-3 years).	Water weekly during periods of no rain to ensure plant establishment.
As Needed	Irrigation		Plant watering	Longer term period (3+ years).	Water during drought conditions or more often if necessary to maintain plant cover.
Ongoing	Spill Prevention and Response		Spill prevention	Storage or use of potential contaminants in the vicinity of facility.	Exercise spill prevention measures whenever handling or storing potential contaminants.
As needed	Spill Prevention and Response		Spill response	Release of pollutants. Call to report any spill to City of Tacoma Source Control 253.502.2222.	Cleanup spills as soon as possible to prevent contamination of stormwater.
At startup	Training and Documentation		Training / written guidance	Training / written guidance is required for proper O&M.	Provide property owners and tenants with proper training and a copy of the O&M manual.
Annually (preferably Sept.)	Safety		Safety (slopes)	Erosion of sides causes slope to exceed 1:4 or otherwise becomes a hazard.	Restore to design slope.
Annually (preferably Sept.)	Safety		Safety (hydraulic structures)	Hydraulic structures (pipes, culverts, vaults, etc.) become a hazard to children playing in and around the facility.	Take actions to eliminate the hazard (such as covering and securing any openings).
Annually (preferably Sept.)	Safety		Line of sight	Vegetation causes some visibility (line of sight) or driver safety issues.	Prune or replace plants as necessary.
Annually (preferably Sept.)	Aesthetics		Aesthetics	Damage/vandalism/debris accumulation.	Clean, repair, and restore facility to original aesthetic conditions.
Annually (preferably Sept.)	Aesthetics		Grass/vegetation	Less than 75% of planted vegetation is healthy with a generally good appearance.	Take appropriate maintenance actions. (e.g., remove/replace plants, amend soil, etc.).

Recommended Frequency	Drainage System Feature	Date	Problem	Conditions to Check For	Maintenance Activities and Conditions that Should Exist
Annually (preferably Sept.)	Aesthetics		Edging	Grass is starting to encroach on facility.	Repair edging. Remove encroaching grass. Install additional measures to prevent encroachment.
Annually (preferably Sept.)	General		Poisonous Vegetation and noxious weeds	Any poisonous or nuisance vegetation may constitute a hazard to maintenance personnel or to the public. Any evidence of noxious weeds as defined by the State or local regulations. The Washington State Noxious Weed Control Board has a list of common noxious weeds at <a href="http://www.nwcb.wa.gov">www.nwcb.wa.gov</a> .	No danger of poisonous vegetation. Compliance with state or local eradication policies is required. Apply requirements of adopted integrated pest management plan as necessary.

If you are unsure whether a problem exists, please contact Environmental Services at 253.591.5588.

Comments:

**#31 - Maintenance Checklist for Trees**

Recommended Frequency	Drainage System Feature	Date	Problem	Conditions to Check For	Maintenance Activities and Conditions that Should Exist
Once a year for the first three years	Trees		Future failure	Weak branch attachments; co-dominant stems.	Structural Pruning <sup>a</sup> .
As needed	Trees		Threat to public safety	Low branches that may cause safety concerns if they remain.	Crown Raising <sup>a</sup> .
As needed, for safety	Trees		Threat to public safety	Dead, diseased and/or broken branches.	Pruning to remove dead, diseased and/or broken branches.
As needed	Trees		Threat to public safety	Dead, severely damaged or declining.	Replace per planting plan or acceptable substitute.

a. Trees shall be pruned according to industry standards, ANSI A300 Part 1 and the International Society of Arboriculture’s Best Management Practices - Tree Pruning.

If you are unsure whether a problem exists, please contact Environmental Services at 253.591.5588.

Comments:



**#32 - Downspout Infiltration Trench or Drywell**

Recommended Frequency	Drainage System Feature	Date	Problem	Conditions to Check For	Maintenance Activities and Conditions that Should Exist
Biannually (Fall and Spring)	Surface of trench/well (i.e., water enters through exposed aggregate)		Water not reaching facility	Accumulated trash, debris, or sediment on drain rock surface impedes sheet flow into facility.	Remove/dispose in accordance with local solid waste requirements.
Annually (At least one visit during the wet season)	Surface of trench/well (i.e., water enters through exposed aggregate)		Water not reaching facility	Vegetation/moss present on drain rock surface impedes sheet flow into facility.	Maintain open, freely draining drain rock surface.
Biannually (Fall and Spring)	Drain Rock		Ponding	If water enters the facility from the surface, inspect to see if water is ponding at the surface during storm events. If buried drain rock, observe drawdown through observation port or cleanout.	Clear piping through facility when ponding occurs. Replace rock/sand reservoirs as necessary. Tilling of subgrade below reservoir may be necessary (for trenches) prior to backfill.
Annually (at least once during the wet season)	Pipe(s)		Water flow issues	Accumulation of trash, debris, or sediment in roof drains, gutters, driveway drains, area drains, etc.	Remove/ dispose.
Annually (at least once during the wet season)	Pipe(s)		Sedimentation	Pipe from sump to trench or drywell has accumulated sediment or is plugged.	Clear sediment from inlet/outlet pipe screen and inlet/outlet pipe. Cleaning operation should not move sediment into rock layer. Remove and dispose of sediment.
Annually (at least once during the wet season)	Pipe(s)		Damaged piping, water flow impeded	Cracked, collapsed, broken, or misaligned drain pipes.	Repair/seal cracks. Replace when repair is insufficient.

Recommended Frequency	Drainage System Feature	Date	Problem	Conditions to Check For	Maintenance Activities and Conditions that Should Exist
Biannually (at least once during the wet season)	Roof Downspout		Erosion Potential	Splash pad missing or damaged.	Repair/ replace.
Annually (at least once during the wet season)	Roof Downspout		Water flow impeded	Leaves or other debris plugging downspout.	Remove/ dispose.
Annually	Sump		Water flow impeded	Sediment in the sump.	Remove/ dispose in accordance with local solid waste requirements.
Annually	Access Lid		Damaged Lid	Cannot be easily opened.	Repair/ replace.
Annually	Access Lid		No lid	Buried.	Refer to record drawings for design intent. If the access lid was designed to be exposed, expose and restore to surface grade.
Annually	Access Lid		Missing lid	Lid not present.	Replace.

If you are unsure whether a problem exists, please contact Environmental Services at 253.591.5588.

**#33 - Downspout Dispersion**

Recommended Frequency	Drainage System Feature	Date	Problem	Conditions to Check For	Maintenance Activities and Conditions that Should Exist
<b>Splashblocks</b>					
Biannually	Splash Block		Water flow incorrect	Water is being directed towards building structure.	Reconfigure/ repair splash blocks to direct water away from building structure.
Biannually	Splash Block		Erosion Potential	Water disrupts soil media.	Reconfigure/ repair blocks, repair eroded soil, replant as necessary.
<b>Sheet Flow Dispersion</b>					
Annually	Transition Zone		Erosion Potential	Adjacent soil erosion; uneven surface creating concentrated flow discharge; or less than 2 feet of width.	Repair/replace transition zone to meet design criteria and eliminate concentrated flows.
<b>Downspout Dispersion – Dispersion Trench</b>					
Annually	Dispersion trench		Water flow issues	Visual evidence of water discharging at concentrated points along trench (normal condition is a “sheet flow” from edge of trench; intent is to prevent erosion damage).	Remove debris from trench surface, if necessary. Realign notched grade board or other distributor type, if possible. Rebuild trench to standards, if necessary.
Biannually (Fall and Spring)	Surface of Dispersion Trench		Flow impeded	Accumulated trash, debris, or sediment on drain rock surface impedes sheet flow from facility.	Remove/dispose in accordance with local solid waste requirements.
Annually (at least once during the wet season)	Surface of Dispersion Trench		Sheet flow impeded	Vegetation/moss present on drain rock surface impedes sheet flow from facility.	Maintain open, freely draining drain rock surface.
Annually (at least once during the wet season)	Pipe to dispersion trench		Flow impeded	Accumulation of trash, debris, or sediment in roof drains, gutters, driveway drains, area drains, etc.	Remove/ dispose.
Annually (at least once during the wet season)	Pipe to dispersion trench		Flow Impeded	Pipe from sump to trench or drywell has accumulated sediment or is plugged.	Clear sediment from inlet/outlet pipe screen and inlet/outlet pipe.

Recommended Frequency	Drainage System Feature	Date	Problem	Conditions to Check For	Maintenance Activities and Conditions that Should Exist
Annually (at least once during the wet season)	Pipe to dispersion trench		Flow Impeded	Cracked, collapsed, broken, or misaligned drain pipes.	Repair/seal cracks. Replace when repair is insufficient.
Annually	Sump		Sediment Buildup	Sediment in the sump.	Remove/ dispose in accordance with local solid waste requirements. Clear sediment from inlet/outlet pipe screen and/or inlet/outlet pipe. Do not flush sediment downstream.
Annually	Access Lid		Damaged Cover	Cannot be easily opened.	Repair/replace.
Annually	Access Lid		No Cover	Buried.	Refer to record drawings for design intent. If the access lid was designed to be exposed, expose and restore to surface grade.
Annually	Access Lid		Missing Cover	Cover missing.	Replace.
Rock Pad (Concentrated Flow Dispersion)					
Annually	Rock pad		Erosion Potential	Only one layer of rock exists above native soil in area 6 square feet or larger, or any exposure of native soil.	Replace/ repair rock pad to meet design standards. Enlarge pad size or add additional courses of rock, if necessary.
Annually	Rock pad		Erosion	Soil erosion in or adjacent to rock pad.	Repair/replace rock pad to meet design standards.
Dispersal Area					
Biannually and After Major Storm Events	Dispersal area (general)		Erosion	Erosion (gullies/ rills) greater than 2 inches deep in dispersal area.	Eliminate cause of erosion and stabilize damaged area (regrade, rock, revegetate).
Biannually and After Major Storm Events	Dispersal area (general)		Flow impeded	Accumulated sediment or debris to extent that blocks or channelizes flowpath.	Remove excess sediment or debris. Identify and control the sediment source (if feasible).

Recommended Frequency	Drainage System Feature	Date	Problem	Conditions to Check For	Maintenance Activities and Conditions that Should Exist
Biannually and After Major Storm Events	Ponded water		Standing water	Standing surface water in dispersion area remains for more than 3 days after the end of a storm event.	Identify the cause of the standing water (e.g., grade depressions, compacted soil) and take appropriate actions to address the problem (e.g., regrade to eliminate depressions or aerate/amend soils).
Biannually	Plant establishment			Dispersal area vegetation in establishment period (1-2 years, or additional 3rd year during extreme dry weather).	Water weekly during periods of no rain to ensure plant establishment.
As Needed	Vegetation		Vegetation cover inadequate	Poor vegetation cover such that erosion is occurring.	Ensure proper care (e.g., watering). Assess for nutrient deficiencies. Replant as needed with appropriate plant species for the soil and moisture conditions. Consider amending soils to promote plant health.
Biannually and After Major Storm Events	Vegetation		Flow impeded.	Vegetation inhibits dispersed flow along flowpath.	Trim, weed or replant to restore dispersed flowpath.
<b>Storage Sump</b>					
Annually	Sump		Sediment	Accumulated sediment in the sump.	Remove/ dispose in accordance with local solid waste requirements. Clear sediment from inlet/outlet pipe screen and/or inlet/outlet pipe.
Annually	Access Lid		Lid Broken	Cannot be easily opened.	Repair/replace.
Annually	Access Lid		Cannot find lid.	Buried.	Expose and restore to surface grade.
Annually	Access Lid		Lid Missing	Lid missing.	Replace.
<b>Pest Control</b>					

Recommended Frequency	Drainage System Feature	Date	Problem	Conditions to Check For	Maintenance Activities and Conditions that Should Exist
As Needed	Pest Control		General Pests	Signs of pest infestations (IPM protocol threshold(s) are exceeded).	Follow IPM protocols for weed and pest management.
Biannually and After Major Storm Events	Pest Control		Mosquitoes	Standing surface water in dispersion area remains for more than 3 days after the end of a storm.	Identify the cause of the standing water and take appropriate actions to address the problem. Do not use pesticides or <i>Bacillus thuringiensis israelensis</i> (Bti).
As Needed	Pest Control		Rodents	Rodent holes or mounds disturb dispersion flowpaths.	Fill and compact soil around the holes and vegetate to restore flowpath.

If you are unsure whether a problem exists, please contact Environmental Services at 253.591.5588

**This Page Intentionally Left Blank**

## **Appendix D Guidelines for Wetlands when Managing Stormwater**

This Appendix provides guidelines on the management of stormwater, from development and redevelopment projects, to avoid or minimize changes to wetland functions and values. Portions of the Tacoma Municipal Code 13.11 may supersede requirements of this section

This appendix consists of six sections:

- D1. Scope and Principles
  - Guide Sheet 1: Criteria that excludes wetlands from serving as a treatment or flow control BMP/facility
  - Guide Sheet 2: Criteria for including wetlands as a treatment or flow control BMP/facility
  - Guide Sheet 3: Wetland protection guidelines
- D2. Information Needed to Apply the Guidelines — This section contains a list of basic data needed for each of the guide sheets to perform basic analyses
- D3. Definitions — Refer to this section for the meaning of terms throughout this appendix.



## D.1 Scope and Principles

### Purpose

Wetlands are important features in the landscape that provide numerous beneficial functions and values for people, fish, and wildlife. Some of these include protecting and improving water quality, providing fish and wildlife habitats, storing floodwaters, and maintaining surface water flow during dry periods.

Development, redevelopment, and stormwater management projects may decrease the functions and values of wetlands by:

- Increasing the amount of water flow discharged to wetlands,
- Decreasing the amount of water flow discharged to wetland,
- Increasing the amount of pollutants discharged to wetland.

These changes can occur even if the wetland is not intentionally used for stormwater management purposes.

These guidelines intend to prevent decreasing the functions and values of wetlands by avoiding alterations to the structural, hydrologic, and water quality characteristics of existing wetlands to the extent possible during development, redevelopment and stormwater management projects.

- Regulatory Requirements

Following these guidelines does not fulfill requirements for assessment and permitting. Every development and redevelopment project should follow the stipulations of the State Environmental Policy Act and contact the local permitting authority. Other state and federal agencies may also have jurisdiction over projects affecting wetlands such as the Washington State Departments of Ecology, Fisheries, and Wildlife; the U.S. Environmental Protection Agency; and the U.S. Army Corps of Engineers.

These guidelines do not address actions needed to enhance or restore degraded wetlands.

- Guideline Basis

These guidelines were principally developed from the results of the Puget Sound Wetlands and Stormwater Management Research Program, as set forth in Sections 2 and 3 of the program's summary publication, *Wetlands and Urbanization, Implications for the Future* (Horner et al. 1997).

- Washington State Wetland Rating System

The wetlands in Washington State differ widely in their functions and values. Washington State's wetland rating systems categorizes wetlands into four categories based on their sensitivity to disturbance, their rarity, our ability to replace them, and the functions they provide.

The rating system, however, does not replace a full assessment of wetland functions that may be necessary to plan and monitor a project of compensatory mitigation.

For more information on the wetlands rating system go to: <http://www.ecy.wa.gov/programs/sea/wetlands/ratingsystems/index.html>.

## **Guide Sheet 1: Criteria that excludes wetlands from serving as a treatment or flow control BMP/facility**

The following types of wetlands are not suitable as stormwater treatment or flow control BMPs/facilities. Engineering structural or hydrologic changes within the wetland itself to improve stormwater flows and water quality are not allowed. Do not increase or decrease the water regime in these wetlands beyond the limits set in Guide Sheet 3. Provide these wetlands with the maximum protection from urban impacts (see Guide Sheet 3: Wetland protection guidelines):

- The wetland is currently a Category I wetland because of special conditions (forested, bog, estuarine, Natural Heritage, coastal lagoon).
- The wetland provides a high level of many functions. These are Category I and II wetlands as determined by the Washington State Wetland Rating System for Western Washington.
- The wetland provides habitat for threatened or endangered species. Determining whether or not the conserved species will be affected by the proposed project requires a careful analysis in relation to the anticipated habitat changes. Consult with the appropriate local, state and federal agencies with jurisdiction over the specific threatened or endangered species on the site.

If a wetland type listed above needs to be included in a stormwater system then this activity is considered an impact. It will be treated as any other impact, and will need to be mitigated according to the rules for wetland mitigation. Project proponents will have to demonstrate that they have done everything to avoid and minimize impacts before proceeding to compensatory mitigation.

The wetlands listed above cannot receive flows from a stormwater system unless the criteria in Guide Sheets 3B and 3C are met.

## **Guide Sheet 2: Criteria for including wetlands as a treatment or flow control BMP/facility**

A wetland can be physically or hydrologically altered to meet the requirements of a treatment or flow control BMP/facility if ALL of the following criteria are met:

- It is classified in the “Washington State Wetland Rating System for Western Washington,” as a Category IV or a Category III wetland with a habitat score of 19 points or less.
- You can demonstrate that there will be “no net loss” of functions and values of the wetland as a result of the structural or hydrologic modifications done to provide control of runoff and water quality. This includes the impacts from the machinery used for the construction. Heavy equipment can often damage the soil structure of a wetland. However, the functions and values of degraded wetlands may sometimes be increased by such alterations and thus would be self-mitigating. Functions and values that are not replaced on site will have to be mitigated elsewhere.
  - Modifications that alter the structure of a wetland or its soils will require permits. Check with the agency(ies) issuing the permits for the modification(s) to determine which method to use to establish “no net loss.”
  - A wetland will usually sustain fewer impacts if the required storage capacity can be met through a modification of the outlet rather than through raising the existing overflow.
- The wetland does not contain a breeding population of any native amphibian species.

- The hydrologic functions of the wetland can be improved as outlined in questions 3,4,5 of Chart 4 and questions 2,3,4 of Chart 5 in the “Guide for Selecting Mitigation Sites Using a Watershed Approach,” (available here: <http://www.ecy.wa.gov/biblio/0906032.html>); or the wetland is part of a priority restoration plan that achieves restoration goals identified in a Shoreline Master Program or other local or regional watershed plan.
- The wetland lies in the natural routing of the runoff, and the discharge follows the natural routing.

Modifications that alter the structure of a wetland or its soils will require permits. Existing functions and values that are lost would have to be compensated/replaced.

### **Guide Sheet 3: Wetland protection guidelines**

This guide sheet provides information on ways to protect wetlands from changes to their ecological structure and functions that result from human alterations of the landscape. It also recommends management actions that can avoid or minimize deleterious changes to wetlands.

Although this guide sheet is intended primarily for the protection of the wetlands listed in Guide Sheet 1; this guidance still should be applied, as practical, for wetlands listed in Guide Sheet 2 when they are modified to meet stormwater requirements.

#### ***Guide Sheet 3A: General guidelines for protecting functions and values of wetlands***

- Consult regulations issued under federal and state laws that govern the discharge of pollutants. Wetlands are classified as "Waters of the United States" and "Waters of the State" in Washington.
- Maintain the wetland buffer required by local regulations.
- Retain areas of native vegetation connecting the wetland and its buffer with nearby wetlands and other contiguous areas of native vegetation.
- Avoid compaction of soil and introduction of exotic plant species during any work in a wetland.
- Take measures to avoid general urban impacts (e. g., littering and vegetation destruction). Examples are protecting existing buffer zones; discouraging access, especially by vehicles, by plantings outside the wetland; and encouragement of stewardship by a homeowners' association.
- Fences can be useful to restrict dogs and pedestrian access, but they also interfere with wildlife movements. Their use should be very carefully evaluated on the basis of the relative importance of intrusive impacts versus wildlife presence. Fences should generally not be installed when wildlife would be restricted and intrusion is relatively minor. They generally should be used when wildlife passage is not a major issue and the potential for intrusive impacts is high. When wildlife movements and intrusion are both issues, the circumstances will have to be weighed to make a decision about fencing.
- If the wetland inlet will be modified for the stormwater management project, use a diffuse flow method, (eg. BMPC206 Level Spreader, Volume 2, Section 3.2.7, and BMP L614 Full Dispersion in Volume 3, Section 3.3) to discharge water into the wetland in order to prevent flow channelization.

#### ***Guide Sheet 3B: Protecting wetlands from impacts of changes in water flows***

Protecting wetland plant and animal communities depends on maintaining the existing wetland's hydroperiod. This means maintaining the annual fluctuations in water depth and its timing as

closely as possible. The risk of impacts to functions and values increases as the changes in water regime deviate more from the existing conditions. These changes often result from development.

Hydrologic modeling is useful to measure or estimate the aspects of the hydroperiod under existing pre-project and anticipated post-project conditions. Post-project estimates of the water regime in a watershed and wetland hydroperiod must include the cumulative effect of all anticipated watershed and wetland modifications. Perform this assessment with the aid of a qualified hydrologist.

*Provisions in these guidelines pertain to the full anticipated build-out of the wetland's watershed as well as changes resulting from an individual development. See Volume 3, Table 3 - 1 for full-build out conditions.*

Unfortunately, attempts to modify and use the standard hydrologic models for describing the flow and fluctuations of water in a stormwater pond have failed to adequately model the hydrodynamics in wetlands. It is difficult to estimate if stormwater discharges to a wetland will meet the criteria for protection developed by the Puget Sound Wetland and Stormwater Research Program. The criteria developed by that program apply only to depressional wetlands. They are not applicable to riverine, slope, or lake-fringe wetlands. Ecology does not have any hydrologic models available to characterize the hydrodynamics in these types of wetlands.

As a result, it is difficult to predict the direct impacts of changes in water flows resulting from a development. In the absence of hydrologic models that characterize all types of wetlands, criteria have to be set using information that is readily available. These criteria are based on risk to the resource rather than an actual understanding of impacts.

The following criteria will provide some protection for the valuable wetland types listed in Guide Sheet 1, but it cannot be determined if the result will completely protect a wetland's functions and values. The risk to wetland functions will increase as the water volumes into the wetland diverge from the pre-project conditions. The risk will be decreased if the divergence is smaller.

Use the Western Washington Hydrology Model (WWHM) for estimating the increases or decreases in total flows (volume) into a wetland that can result from the development project. These total flows can be modeled for individual days or on a monthly basis. Compare the results from this modeling to the criterion below.

**Criterion 1: total volume of water into a wetland during a single precipitation event should not be more than 20% higher or lower than the pre-project volumes.**

WWHM 2012 calculates the average daily volumes for pre-project and post-project scenarios and provides the 20% comparison. If using an alternative continuous simulation model, additional calculations may be required by the applicant to prove Criterion 1 is met.

Modeling algorithm for Criterion 1

- Daily Volumes can be calculated for each day over 50 years for Pre- and Post-project scenarios. Volumes are to be calculated at the inflow to the wetland or the upslope edge where surface runoff, interflow, and groundwater are assumed to enter.
- Calculate the average of Daily Volume for each day for Pre- and Post-project scenarios. There will be 365 values for the Pre-project scenario and 365 for the Post-project.

Example calc for each day in a year (e.g., April 1):

- If you use 50 years of precipitation data, there will be 50 values for April 1. Calculate the average of the 50, April 1, Daily Volumes for Pre- and Post-project scenarios.
- Compare the average Daily Volumes for Pre- versus Post-project scenarios for each day. The average Post-project Daily Volume for April 1 must be within +/- 20% of the Pre-project Daily Volume for April 1.
  - Check compliance with the 20% criterion for each day of year. Criterion 1 is met/ passed if none of the 365 post-project daily volumes varies by more than 20% from the pre-project daily volume for that day.

**Criterion 2: Total volume of water into a wetland on a monthly basis should not be more than 15% higher or lower than the pre-project volumes.**

WWHM 2012 calculates the average monthly volumes for pre-project and post-project scenarios and provides the 15% comparison. If using an alternative continuous simulation model, additional calculations may be required by the applicant to prove Criterion 2 is met.

This needs to be calculated based on the average precipitation for each month of the year. This criterion is especially important for the summer months when a development may reduce the monthly flows rather than increase them because of reduced infiltration and recharging of ground water.

**Modeling algorithm for Criterion 2**

- Monthly Volumes can be calculated for each calendar month over 50 years for Pre- and Post-project scenarios. Volumes are to be calculated at the inflow to the wetland or the upslope edge where surface runoff, interflow, and ground water are assumed to enter.
- Calculate the average of Monthly Volume for each calendar month for Pre- and Post-project scenarios.

Example calc for each calendar month in a year (e.g., April):

- If you use 50 years of precipitation data, there will be 50 values for the month of April. Calculate the average of the 50, April, Monthly Volumes for Pre- and Post-project scenarios.
- Compare the Monthly Volumes for Pre- versus Post-project scenarios. Post- project Monthly Volume for April must be within +/- 15% of the Pre- project Monthly Volume for April.
- Check compliance with the 15% criterion for each calendar month of year. Criterion 2 is met/passed if none of the post- project Monthly Volume varies by more than 15% from the pre- project Monthly Volume for every month.

**WWHM Modeling Assumption and Approach**

**Assumption** - Flow components feeding the wetland under both Pre- and Post-project scenarios are assumed to be the sum of the surface, interflow, and groundwater flows from the project site.

**Approach** - Assign the wetland a point of compliance #1 (POC) number such as POC1 downstream of the project area.

- A. Pre-project scenario - Connect all flow components to the wetland/POC1
  - Pre-project Total Flows to POC1 = Surface + Interflow + Groundwater

B. Post-project scenario - Identify flows to the wetland/POC1.

- Impervious surfaces send flows to wetland via (1)- surface flow.
  - WWHM sub-flows to POC1 = Surface flow (+ Interflow default set in WWHM)
- Pervious surfaces send flows to wetland via (1)- surface, (2)- interflow, and (3)- ground.
  - WWHM sub-flows to POC1 = Surface + Interflow + Groundwater

C. Infiltrating facilities send flows to wetland via ground water, and surface overflows.

- Groundwater - Connect infiltrated water (Outlet 2) to groundwater component of the area between facility and wetland. Use Lateral Basin downstream of the infiltrating facility and connect Outlet 2 to the ground water component of the Lateral Basin. If this area is the same area modeled in Step (b) above, use the Lateral Basin element in Step (b).
  - WWHM sub-flows to POC1 = infiltrated flows
- Surface Overflow – Connect the surface flow (Outlet 1) to wetland/POC1
  - WWHM sub-flows to POC1 = facility surface flows (Outlet 1)
  - Post-project Total Flows to POC1 = Sum of flows in (A), (B), and (C).

If it is expected that the limits stated above could be exceeded, consider the following strategies to reduce the volume of surface flows:

- Reducing of the level of development by reducing the amount of impervious surface and/or increasing the retention of natural forest cover.
- Increasing infiltration through the use of LID BMPs and LID principles.
- Increasing storage capacity for surface runoff.
- Using selective runoff bypass around the wetland. Bypassed flow must still comply with other applicable stormwater requirements.

**Monitoring** – Modifications that alter the structure of a wetland or its soils will require permits. Conduct monitoring as required by local, state, or federal permits.

### **Guide Sheet 3C: Guidelines for protecting wetlands from pollutants**

Protecting a wetland from pollutants generated by a development should include the following measures:

- Use effective erosion control at construction sites in the wetland's drainage catchment. Refer to Volume II this manual and local jurisdiction requirements.
- Institute a program of source control BMPs and minimize the pollutants that will enter storm runoff that drains to the wetland.
- For wetlands that meet the criteria in Guide Sheet 1, provide a water quality control facility consisting of one or more treatment BMPs to treat runoff entering the wetland.
  - If the wetland is a Category I wetland because of special conditions (forested, bog, estuarine, Natural Heritage, coastal lagoon), the facility should include a BMP with the most advanced ability to control nutrients.

## D.2 Information Needed to Apply the Guidelines

Each guide sheet requires collecting specific information. The following sections list the basic data needed for applying the Guide Sheets. As a start, obtain the relevant soil survey; the National Wetland Inventory for the watershed, topographic and land use maps, and the results of any local wetland inventory.

### Data Needed for Guide Sheet 1: Criteria for Excluding Wetlands as Part of a Stormwater System

- Wetland category Ecology's "Washington State Wetland Rating System for Western Washington," available on-line at <http://www.ecy.wa.gov/biblio/sea.html>.
- Rare, threatened, or endangered species inhabiting the wetland.
- Presence or absence of a breeding population of native amphibians. If amphibians are found in the wetland assume they are native unless you can demonstrate the only species present are non-native.

### Data Needed for Guide Sheet 2: Criteria for Including Wetlands as Part of a Stormwater System

- Hydrologic modeling of the existing flows and predicted flows into the wetland.
- A characterization of the changes to water quality coming into the wetland from the development.
- Presence of breeding populations of native amphibian species.
- Presence of fish species.

### Data Needed for Guide Sheet 3B: Protecting wetlands from impacts of changes in water flows

The WWHM user manual contains a modeling procedure for estimating water flows to wetlands. Follow the modeling procedure in WWHM user manual to estimate flows and determine compliance with the wetland Criteria 1 and 2. The information needed to model water flows to a wetland in WWHM includes the following:

- Location of the development project
- Land use characteristics before and after development.
  - Soil Type
  - Surface Vegetation
  - Land slope
  - Land area (acres)
- Land use characteristics between the development project area and the wetland.

### D.3 Definitions

The following terms are applicable only to this appendix (Appendix D).

<b>Baseline sampling</b>	Sampling performed to define the existing environmental and biological conditions present before any modification occurs.
<b>Bioengineering</b>	Bioengineering for streams and wetlands --The use of living and nonliving plant materials in combination with natural and synthetic support materials for slope stabilization, erosion reduction, and vegetative establishment.
<b>Buffer</b>	The area (either upland, open water, or another wetland) that surrounds a wetland and that reduces adverse impacts to it from adjacent development.
<b>Constructed wetland</b>	A wetland intentionally created from a non-wetland site.
<b>Degraded wetland</b>	A wetland whose functions and values have been reduced as a result of human activities.
<b>Enhancement</b>	The manipulation of the physical, chemical, or biological characteristics of a wetland site to heighten, intensify or improve specific function(s) or to change the growth stage or composition of the vegetation present. Enhancement is undertaken for specified purposes such as water quality improvement, flood water retention or wildlife habitat. Activities typically consist of planting vegetation, controlling non-native or invasive species, modifying site elevations or the proportion of open water to influence hydroperiods, or some combination of these. Enhancement results in a change in some wetland functions and can lead to a decline in other wetland functions, but does not result in a gain in wetland acres.
<b>Estuarine wetland</b>	Generally, a vegetated wetland where the salinity of the surface or port waters is greater than 0.5 parts per thousand.
<b>Functions</b>	The ecological (physical, chemical, and biological) processes or attributes of a wetland. Functions are often defined in terms of the processes that provide value to society, but they can be defined on processes that are not value based. Wetland functions include food chain support, provision of ecosystem diversity and fish and wildlife habitat, flood flow alteration, ground water recharge and discharge, water quality improvement, and soil stabilization.
<b>Hydrodynamics</b>	The science involving the energy and forces acting on water or other liquids and the resulting impact on the motion of the liquid.
<b>Hydroperiod</b>	The seasonal occurrence of flooding and/or soil saturation; encompasses the depth, frequency, duration, and seasonal pattern of inundation.



<b>Invasive plant species</b>	Opportunistic plant species (either native or non-native) that colonize disturbed ecosystems and come to dominate the plant community in ways that are seen by us as reducing the values provided by the previous plant community. Most often, opportunistic plants are considered invasive if they reduce the value of an area as habitat for valuable species.
<b>Landscape unit</b>	An area of land that has a specified boundary used for planning purposes that defines an area of interrelated physical, chemical, and biological processes. A watershed or drainage basin is a common type of landscape unit. A groundwater aquifer is another type of landscape unit.
<b>Modification, Modified (wetland)</b>	A wetland whose physical, hydrological, or water quality characteristics have been purposefully altered for a management purpose, such as by dredging, filling, forebay construction, and inlet or outlet control.
<b>On-site</b>	An action (here, for stormwater management purposes) taken within the property boundaries of the site to which the action applies.
<b>Polishing</b>	Additional treatment of a waste stream that has already received one or more stages of treatment by other means. This is also called advanced treatment.
<b>Post-project</b>	The conditions present across a landscape after a specific stormwater management project (e. g., raising the outlet, building an outlet control structure) are placed in the wetland or a land use change that occurs in the landscape unit that will potentially affect the wetland.
<b>Pre-project</b>	The conditions present across a landscape before a specific stormwater management project (e. g., raising the outlet, building an outlet control structure) are placed in the wetland or a land use change occurs in the landscape unit that will potentially affect the wetland.
<b>Rare, threatened, or endangered species</b>	Plant or animal species that are regional relatively uncommon, are nearing endangered status, or whose existence is in immediate jeopardy and is usually restricted to highly specific habitats. Threatened and endangered species are officially listed by federal and state authorities, whereas rare species are unofficial species of concern that fit the above definitions.
<b>Redevelopment</b>	Conversion of an existing development to another land use, or addition of a material improvement to an existing development.
<b>Regional</b>	An action (here, for stormwater management purposes) that involves more than one discrete property.

<b>Re-establishment</b>	Actions performed to reestablish wetland functional characteristics and processes that have been lost by alterations, activities, or catastrophic events in an area that no longer meets the definition of a wetland.
<b>Structure</b>	The physical components of an ecosystem, both the abiotic (physical and chemical) and biotic (living).
<b>Values</b>	Wetland processes or attributes that are valuable or beneficial to society (also see Functions on page 205 of Volume 1, Appendix D). Wetland values include support of commercial and sport fish and wildlife species, protection of life and property from flooding, recreation, education, and aesthetic enhancement of human communities.
<b>Wetlands</b>	Those areas that are inundated or saturated by surface or groundwater at a frequency and duration sufficient to support, and that under normal circumstances do support, a prevalence of vegetation typically adapted for life in saturated soil conditions. Wetlands generally include swamps, marshes, bogs, and similar areas. Wetlands do not include those artificial wetlands intentionally created from nonwetland sites, including, but not limited to, irrigation and drainage ditches, grass-lined swales, canals, detention facilities, wastewater treatment facilities, farm ponds, and landscape amenities, or those wetlands created after July 1, 1990, that were unintentionally created as a result of the construction of a road, street, or highway. Wetlands may include those artificial wetlands intentionally created from nonwetland areas to mitigate the conversion of wetlands. (Waterbodies not included in the definition of wetlands as well as those mentioned in the definition are still waters of the state.)

**This Page Intentionally Left Blank**

# Volume 2 - Stormwater Management for Construction Sites

## Table of Contents

Purpose of this Volume . . . . .	2-1
Content and Organization of this Volume . . . . .	2-1
<b>Chapter 1 The 13 Elements of Construction Stormwater Pollution Prevention . . . . .</b>	<b>2-3</b>
<b>Chapter 2 Developing a Construction Stormwater Pollution Prevention Plan (SWPPP) 2-15</b>	
2.1 General Requirements and Guidelines . . . . .	2-15
2.2 BMP Standards and Specifications . . . . .	2-16
2.3 Step-by-Step Procedure . . . . .	2-16
2.3.1 Step 1 – Data Collection . . . . .	2-16
2.3.2 Step 2 – Data Analysis . . . . .	2-17
2.3.3 Step 3 – Construction SWPPP Development and Analysis . . . . .	2-18
<b>Chapter 3 Standards and Specifications for Best Management Practices (BMPs) . . . . .</b>	<b>2-25</b>
3.1 Source Control BMPs . . . . .	2-26
3.1.1 BMP C101: Preserving Natural Vegetation . . . . .	2-27
3.1.1.1 Purpose . . . . .	2-27
3.1.1.2 Conditions of Use . . . . .	2-28
3.1.1.3 Design and Installation Specifications . . . . .	2-28
3.1.1.4 Maintenance Standards . . . . .	2-28
3.1.2 BMP C102: Buffer Zone . . . . .	2-29
3.1.2.1 Purpose . . . . .	2-29
3.1.2.2 Conditions of Use . . . . .	2-29
3.1.2.3 Design and Installation Specifications . . . . .	2-29
3.1.2.4 Maintenance Standards . . . . .	2-29
3.1.3 BMP C103: High Visibility Fence . . . . .	2-30
3.1.3.1 Purpose . . . . .	2-30
3.1.3.2 Conditions of Use . . . . .	2-30
3.1.3.3 Design and Installation Specifications . . . . .	2-30
3.1.3.4 Maintenance Standards . . . . .	2-30
3.1.4 BMP C105: Stabilized Construction Entrance/Exit . . . . .	2-31
3.1.4.1 Purpose . . . . .	2-31
3.1.4.2 Conditions of Use . . . . .	2-31
3.1.4.3 Design and Installation Specifications . . . . .	2-31
3.1.4.4 Maintenance Standards . . . . .	2-31
3.1.5 BMP C106: Wheel Wash . . . . .	2-35
3.1.5.1 Purpose . . . . .	2-35
3.1.5.2 Conditions of Use . . . . .	2-35
3.1.5.3 Design and Installation Specifications . . . . .	2-35
3.1.5.4 Maintenance Standards . . . . .	2-35
3.1.6 BMP C107: Construction Road/Parking Area Stabilization . . . . .	2-37
3.1.6.1 Purpose . . . . .	2-37
3.1.6.2 Conditions of Use . . . . .	2-37
3.1.6.3 Design and Installation Specifications . . . . .	2-37

- 3.1.6.4 Maintenance Standards . . . . . 2-38
- 3.1.7 BMP C120: Temporary and Permanent Seeding . . . . . 2-39
  - 3.1.7.1 Purpose . . . . . 2-39
  - 3.1.7.2 Conditions of Use . . . . . 2-39
  - 3.1.7.3 Design and Installation Specifications . . . . . 2-39
  - 3.1.7.4 Maintenance Standards . . . . . 2-41
- 3.1.8 BMP C121: Mulching . . . . . 2-44
  - 3.1.8.1 Purpose . . . . . 2-44
  - 3.1.8.2 Conditions of Use . . . . . 2-44
  - 3.1.8.3 Design and Installation Specifications . . . . . 2-44
  - 3.1.8.4 Maintenance Standards . . . . . 2-44
- 3.1.9 BMP C122: Nets and Blankets . . . . . 2-48
  - 3.1.9.1 Purpose . . . . . 2-48
  - 3.1.9.2 Conditions of Use . . . . . 2-48
  - 3.1.9.3 Design and Installation Specifications . . . . . 2-48
  - 3.1.9.4 Maintenance Standards . . . . . 2-50
- 3.1.10 BMP C123: Plastic Covering . . . . . 2-53
  - 3.1.10.1 Purpose . . . . . 2-53
  - 3.1.10.2 Conditions of Use . . . . . 2-53
  - 3.1.10.3 Design and Installation Specifications . . . . . 2-53
  - 3.1.10.4 Maintenance Standards . . . . . 2-54
- 3.1.11 BMP C124: Sodding . . . . . 2-56
  - 3.1.11.1 Purpose . . . . . 2-56
  - 3.1.11.2 Conditions of Use . . . . . 2-56
  - 3.1.11.3 Design and Installation Specifications . . . . . 2-56
  - 3.1.11.4 Maintenance Standards . . . . . 2-57
- 3.1.12 BMP C125: Compost . . . . . 2-58
  - 3.1.12.1 Purpose . . . . . 2-58
  - 3.1.12.2 Conditions of Use . . . . . 2-58
  - 3.1.12.3 Design and Installation Specifications . . . . . 2-58
  - 3.1.12.4 Maintenance Standards . . . . . 2-59
- 3.1.13 BMP C126: Topsoiling . . . . . 2-60
  - 3.1.13.1 Purpose . . . . . 2-60
  - 3.1.13.2 Conditions of Use . . . . . 2-60
  - 3.1.13.3 Design and Installation Specifications . . . . . 2-60
  - 3.1.13.4 Maintenance Standards . . . . . 2-62
- 3.1.14 BMP C127: Polyacrylamide for Soil Erosion Protection . . . . . 2-63
  - 3.1.14.1 Purpose . . . . . 2-63
  - 3.1.14.2 Conditions of Use . . . . . 2-63
  - 3.1.14.3 Design and Installation Specifications . . . . . 2-63
  - 3.1.14.4 Maintenance Standards . . . . . 2-65
- 3.1.15 BMP C130: Surface Roughening . . . . . 2-66
  - 3.1.15.1 Purpose . . . . . 2-66
  - 3.1.15.2 Conditions for Use . . . . . 2-66
  - 3.1.15.3 Design and Installation Specifications . . . . . 2-66
  - 3.1.15.4 Maintenance Standards . . . . . 2-66
- 3.1.16 BMP C131: Gradient Terraces . . . . . 2-68
  - 3.1.16.1 Purpose . . . . . 2-68
  - 3.1.16.2 Conditions of Use . . . . . 2-68
  - 3.1.16.3 Design and Installation Specifications . . . . . 2-68
  - 3.1.16.4 Maintenance Standards . . . . . 2-69
- 3.1.17 BMP C140: Dust Control . . . . . 2-70

3.1.17.1 Purpose . . . . .	2-70
3.1.17.2 Conditions of Use . . . . .	2-70
3.1.17.3 Design and Installation Specifications . . . . .	2-70
3.1.17.4 Maintenance Standards . . . . .	2-71
3.1.18 BMP C150: Materials On Hand . . . . .	2-72
3.1.18.1 Purpose . . . . .	2-72
3.1.18.2 Conditions of Use . . . . .	2-72
3.1.18.3 Design and Installation Specifications . . . . .	2-72
3.1.18.4 Maintenance Standards . . . . .	2-72
3.1.19 BMP C151: Concrete Handling . . . . .	2-73
3.1.19.1 Purpose . . . . .	2-73
3.1.19.2 Conditions of Use . . . . .	2-73
3.1.19.3 Design and Installation Specifications . . . . .	2-73
3.1.19.4 Maintenance Standards . . . . .	2-74
3.1.20 BMP C152: Sawcutting and Surfacing Pollution Prevention . . . . .	2-75
3.1.20.1 Purpose . . . . .	2-75
3.1.20.2 Conditions of Use . . . . .	2-75
3.1.20.3 Design and Installation Specifications . . . . .	2-75
3.1.20.4 Maintenance Standards . . . . .	2-75
3.1.21 BMP C153: Material Delivery, Storage and Containment . . . . .	2-76
3.1.21.1 Purpose . . . . .	2-76
3.1.21.2 Conditions of Use . . . . .	2-76
3.1.21.3 Design and Installation Specifications . . . . .	2-76
3.1.21.4 Material Storage Areas and Secondary Containment Practices: . . . . .	2-77
3.1.21.5 Maintenance . . . . .	2-77
3.1.22 BMP C154: Concrete Washout Area . . . . .	2-78
3.1.22.1 Purpose . . . . .	2-78
3.1.22.2 Conditions of Use . . . . .	2-78
3.1.22.3 Implementation . . . . .	2-78
3.1.22.4 Education . . . . .	2-78
3.1.22.5 Location and Placement Considerations: . . . . .	2-79
3.1.22.6 Onsite Temporary Concrete Washout Facility, Transit Truck Washout Procedures: . . . . .	2-79
3.1.22.7 Inspection and Maintenance . . . . .	2-80
3.1.22.8 Removal of Temporary Concrete Washout Facilities . . . . .	2-81
3.1.23 BMP C160: Erosion and Sediment Control Lead . . . . .	2-84
3.1.23.1 Purpose . . . . .	2-84
3.1.23.2 Conditions of Use . . . . .	2-84
3.1.23.3 Specifications . . . . .	2-84
3.1.24 BMP C161: Payment of Erosion Control Work . . . . .	2-86
3.1.24.1 Purpose . . . . .	2-86
3.1.25 BMP C162: Scheduling . . . . .	2-87
3.1.25.1 Purpose . . . . .	2-87
3.1.25.2 Conditions of Use . . . . .	2-87
3.1.25.3 Design Considerations . . . . .	2-87
3.2 Runoff, Conveyance and Treatment BMPs . . . . .	2-88
3.2.1 BMP C200: Interceptor Dike and Swale . . . . .	2-89
3.2.1.1 Purpose . . . . .	2-89
3.2.1.2 Conditions of Use . . . . .	2-90
3.2.1.3 Design and Installation Specifications . . . . .	2-90
3.2.2 BMP C201: Grass-Lined Channels . . . . .	2-92
3.2.2.1 Purpose . . . . .	2-92

3.2.2.2	Conditions of Use . . . . .	2-92
3.2.2.3	Design and Installation Specifications . . . . .	2-92
3.2.2.4	Maintenance Standards . . . . .	2-93
3.2.3	BMP C202: Channel Lining . . . . .	2-96
3.2.3.1	Purpose . . . . .	2-96
3.2.3.2	Conditions of Use . . . . .	2-96
3.2.3.3	Design and Installation Specifications . . . . .	2-96
3.2.4	BMP C203: Water Bars . . . . .	2-98
3.2.4.1	Purpose . . . . .	2-98
3.2.4.2	Conditions of Use . . . . .	2-98
3.2.4.3	Design and Installation Specifications . . . . .	2-98
3.2.4.4	Maintenance Standards . . . . .	2-99
3.2.5	BMP C204: Pipe Slope Drains . . . . .	2-100
3.2.5.1	Purpose . . . . .	2-100
3.2.5.2	Conditions of Use . . . . .	2-100
3.2.5.3	Design and Installation Specifications . . . . .	2-100
3.2.5.4	Maintenance Standards . . . . .	2-101
3.2.6	BMP C205: Subsurface Drains . . . . .	2-103
3.2.6.1	Purpose . . . . .	2-103
3.2.6.2	Conditions of Use . . . . .	2-103
3.2.6.3	Design and Installation Specifications . . . . .	2-103
3.2.6.4	Maintenance Standards . . . . .	2-104
3.2.7	BMP C206: Level Spreader . . . . .	2-105
3.2.7.1	Purpose . . . . .	2-105
3.2.7.2	Conditions of Use . . . . .	2-105
3.2.7.3	Design and Installation Specifications . . . . .	2-105
3.2.7.4	Maintenance Standards . . . . .	2-106
3.2.8	BMP C207: Check Dams . . . . .	2-107
3.2.8.1	Purpose . . . . .	2-107
3.2.8.2	Conditions of Use . . . . .	2-107
3.2.8.3	Design and Installation Specifications . . . . .	2-107
3.2.8.4	Maintenance Standards . . . . .	2-108
3.2.9	BMP C208: Triangular Silt Dike (Geotextile-Encased Check Dam) . . . . .	2-110
3.2.9.1	Purpose . . . . .	2-110
3.2.9.2	Conditions of Use . . . . .	2-110
3.2.9.3	Design and Installation Specifications . . . . .	2-110
3.2.9.4	Maintenance Standards . . . . .	2-110
3.2.10	BMP C209: Outlet Protection . . . . .	2-112
3.2.10.1	Purpose . . . . .	2-112
3.2.10.2	Conditions of Use . . . . .	2-112
3.2.10.3	Design and Installation Specifications . . . . .	2-112
3.2.10.4	Maintenance Standards . . . . .	2-112
3.2.11	BMP C220: Storm Drain Inlet Protection . . . . .	2-113
3.2.11.1	Purpose . . . . .	2-113
3.2.11.2	Conditions of Use . . . . .	2-113
3.2.11.3	Design and Installation Specifications . . . . .	2-113
3.2.11.4	Maintenance Standards . . . . .	2-121
3.2.12	BMP C231: Brush Barrier . . . . .	2-123
3.2.12.1	Purpose . . . . .	2-123
3.2.12.2	Conditions of Use . . . . .	2-123
3.2.12.3	Design and Installation Specifications . . . . .	2-123
3.2.12.4	Maintenance Standards . . . . .	2-123

3.2.13 BMP C232: Gravel Filter Berm	2-125
3.2.13.1 Purpose	2-125
3.2.13.2 Conditions of Use	2-125
3.2.13.3 Design and Installation Specifications	2-125
3.2.13.4 Maintenance Standards	2-125
3.2.14 BMP C233: Silt Fence	2-126
3.2.14.1 Purpose	2-126
3.2.14.2 Conditions of Use	2-126
3.2.14.3 Design and Installation Specifications	2-126
3.2.14.4 Maintenance Standards	2-129
3.2.15 BMP C234: Vegetated Strip	2-132
3.2.15.1 Purpose	2-132
3.2.15.2 Conditions of Use	2-132
3.2.15.3 Design and Installation Specifications	2-132
3.2.15.4 Maintenance Standards	2-132
3.2.16 BMP C235: Wattles	2-133
3.2.16.1 Purpose	2-133
3.2.16.2 Conditions of Use	2-133
3.2.16.3 Design Criteria	2-133
3.2.16.4 Maintenance Standards	2-134
3.2.17 BMP C236: Vegetative Filtration	2-136
3.2.17.1 Purpose	2-136
3.2.17.2 Conditions of Use	2-136
3.2.17.3 Design Criteria	2-136
3.2.17.4 Maintenance Standards	2-137
3.2.18 BMP C240: Sediment Trap	2-138
3.2.18.1 Purpose	2-138
3.2.18.2 Conditions of Use	2-138
3.2.18.3 Design and Installation Specifications	2-139
3.2.18.4 Maintenance Standards	2-141
3.2.19 BMP C241: Temporary Sediment Pond	2-142
3.2.19.1 Purpose	2-142
3.2.19.2 Conditions of Use	2-142
3.2.19.3 Design and Installation Specifications	2-142
3.2.19.4 Maintenance Standards	2-145
3.2.20 BMP C250: Construction Stormwater Chemical Treatment	2-149
3.2.20.1 Purpose	2-149
3.2.20.2 Conditions of Use	2-149
3.2.20.3 Design and Installation Specifications	2-149
3.2.20.4 Monitoring	2-154
3.2.21 BMP C251: Construction Stormwater Filtration	2-156
3.2.21.1 Purpose	2-156
3.2.21.2 Conditions of Use	2-156
3.2.21.3 Background Information	2-156
3.2.21.4 Design and Installation Specifications	2-156
3.2.21.5 Maintenance Standards	2-159
3.2.22 BMP C252: High pH Neutralization using CO <sub>2</sub>	2-160
3.2.22.1 Description	2-160
3.2.22.2 Treatment Procedures	2-161
3.2.22.3 Safety and Materials Handling	2-161
3.2.22.4 Operator Records	2-161
3.2.23 BMP C253: pH Control for High pH Water	2-163



3.2.23.1 Description . . . . .2-163  
3.2.23.2 Disposal Methods. . . . .2-163  
**Appendix A Standard Notes for Temporary Erosion and Sedimentation Control Plans . . .  
2-165**  
**Appendix B Construction SWPPP Short Form . . . . .2-167**



# Stormwater Management for Construction Sites

## Purpose of this Volume

This volume of the Stormwater Management Manual discusses stormwater impacts and controls associated with construction activities. It addresses the planning, design, and implementation of stormwater management activities prior to and during the construction phase of projects.

The purpose of this volume is to provide guidance to prevent construction activities from adversely impacting downstream resources and onsite stormwater flows. Prevention of soil erosion, capture of water-borne and air-borne sediment that has been unavoidably released from exposed soils, and protection of water quality from onsite pollutant sources are all readily achievable when the proper Best Management Practices (BMPs) are planned, installed, and properly maintained.

## Content and Organization of this Volume

Volume 2 consists of three chapters and three appendices that address the preparation and implementation of Construction Stormwater Pollution Prevention Plans (SWPPPs).

- Chapter 1 describes the 13 elements of stormwater pollution prevention.
- Chapter 2 presents a step-by-step method for developing a Construction SWPPP. It encourages examination of all possible conditions that could reasonably affect a particular project's stormwater control systems during the construction phase of the project.
- Chapter 3 contains BMPs for construction stormwater control and site management. The first section of Chapter 3 contains BMPs for Source Control. The second section addresses runoff, conveyance, and treatment BMPs. Various combinations of these BMPs should be used in the Construction SWPPP to satisfy each of the 13 elements applying to the project.

- Appendix A provides standard notes that should be used on the project Stormwater Pollution Prevention Plan (SWPPP) and associated drawings.
- Appendix B provides the criteria and guidelines for creating a SWPPP Short Form.

## **Chapter 1 The 13 Elements of Construction Stormwater Pollution Prevention**

The 13 elements of construction stormwater pollution prevention cover the general water quality protection strategies of limiting site impacts, preventing erosion and sedimentation, and managing activities and sources. The applicant is required to address the following 13 elements in the construction stormwater pollution prevention plan (SWPPP). If an element is considered unnecessary, the Construction SWPPP must describe why that element is not needed.

The 13 elements are:

- Element 1 – Mark Clearing Limits
- Element 2 – Establish Construction Access
- Element 3 – Control Flow Rates
- Element 4 – Install Sediment Controls
- Element 5 – Stabilize Soils
- Element 6 – Protect Slopes
- Element 7 – Protect Drain Inlets
- Element 8 – Stabilize Channels and Outlets
- Element 9 – Control Pollutants
- Element 10 – Control Dewatering
- Element 11 – Maintain BMPs
- Element 12 – Manage the Project
- Element 13 – Protect BMPs

### ***Element #1: Preserve Vegetation and Mark Clearing Limits***

- Before beginning any land disturbing activities, including clearing and grading, clearly mark all clearing limits, sensitive areas and their buffers, and trees that are to be preserved within the construction area to prevent damage and offsite impacts. Mark clearing limits both in the field and on the plans.
- Retain the duff layer, native topsoil, and natural vegetation in an undisturbed state to the maximum extent practicable. If it is not practicable to retain the duff layer in place, it should be stockpiled onsite, covered to prevent erosion, and replaced immediately upon completion of the ground-disturbing activities.
- Plastic, metal, or fabric fence may be used to mark the clearing limits.
- Suggested BMPs (Refer to Chapter 3):
  - BMP C101: Preserving Natural Vegetation
  - BMP C102: Buffer Zones
  - BMP C103: High Visibility Fence
  - BMP C233: Silt Fence

**Element #2: Establish Construction Access**

- Construction vehicle ingress and egress shall be limited to one route. Additional routes may be allowed for very large projects or linear projects. The construction access may have to be moved if the project is phased.
- Access points shall be stabilized per BMP C105 – Stabilized Construction Entrance or other City of Tacoma approved equivalent BMPs.
- Wheel wash or tire baths shall be located on site, if applicable. Wheel washes shall be required if other measures fail to control sediment from leaving the site.
- No tracking of sediment onto the roadway is allowed. If sediment is tracked onto the road, the road shall be thoroughly and immediately cleaned by shoveling or pickup sweeping. Transport sediment to a controlled sediment disposal area.
- Keep streets clean at ALL times. Clean tracked sediment immediately.
- Street washing of sediment to the storm drain system is not allowed.
- Suggested BMPs (Refer to Chapter 3):
  - BMP C105: Stabilized Construction Entrance/Exit
  - BMP C106: Wheel Wash
  - BMP C107: Construction Road/Parking Area Stabilization

**Element #3: Control Flow Rates**

- Protect properties and waterways downstream of development sites from erosion due to increases in the volume, velocity, and peak flow rate of stormwater runoff from the project site. Requirements of the City of Tacoma Critical Areas Protection Ordinance (TMC 13.11) must be followed during construction as applicable.
- Conduct a downstream analysis if changes to offsite flows could impair or alter conveyance systems, stream banks, bed sediment, or aquatic habitat. See Volume 1, Chapter 3 – Minimum Requirement #10 for offsite analysis guidelines.
- Where necessary, construct stormwater detention facilities as one of the first steps in grading. Detention facilities shall be functional prior to construction of site improvements (e.g. impervious surfaces). It may be necessary to install temporary detention facilities to meet detention requirements during construction.
- Baker tanks or similar may be used to help control flow rates. Calculations for the proposed size of the tank shall be provided to Environmental Services.
- Sites that must implement flow control for the developed condition must also control stormwater release rates during construction. Construction site stormwater discharges shall not exceed the discharge durations of the predeveloped condition for the range of predeveloped discharge rates from ½ of the 2-year flow through the 10-year flow as predicted by WWHM. The predeveloped condition to be matched shall be the land cover condition immediately prior to the project.
- During construction, the City may require non-standard temporary sediment control pond designs in order to provide additional flow control necessary to address local conditions or to protect properties and waterways downstream from erosion due to construction activities.
- Permanent infiltration ponds shall not be used for flow control during construction unless specifically allowed in writing by Environmental Services. If allowed, these facilities shall

be protected from siltation during the construction phase as required by Environmental Services. A liner may be required. The ponds shall be excavated to final grade after the site is stabilized.

- Suggested BMPs (Refer to Chapter 3):
  - BMP C240: Sediment Trap
  - BMP C241: Temporary Sediment Pond
  - BMP C203: Water Bars
  - BMP C207: Check Dams
  - BMP C209: Outlet Protection
  - BMP C235: Wattles

#### ***Element #4: Install Sediment Controls***

- Design, install, and maintain effective erosion controls and sediment control to minimize the discharge of pollutants.
- Minimize sediment discharges from the site. The design, installation and maintenance of erosion and sediment controls must address factors such as the amount, frequency, intensity and duration of precipitation, the nature of resulting stormwater runoff, and soil characteristics, including the range of soil particle sizes expected to be present on the site.
- Prior to leaving a construction site or prior to discharge to an infiltration facility, stormwater runoff from disturbed areas shall pass through a sediment pond or other appropriate sediment removal BMP.
- Construct sediment control BMPs as one of the first steps in grading. These BMPs shall be functional before other land disturbing activities take place.
- Locate BMPs in a manner to avoid interference with the movement of juvenile salmonids attempting to enter off-channel areas or drainages.
- Seed and mulch earthen structures such as dams, dikes, and diversions according to the timing indicated in Element #5.
- Design outlet structures to withdraw impounded stormwater from the surface to avoid discharging sediment that is still suspended lower in the water column. If installing a floating pump structure, include a stopper to prevent the pump basket from hitting the bottom of the pond.
- Full stabilization includes concrete or asphalt paving; quarry spalls used as ditch lining; or the use of rolled erosion products, a bonded fiber matrix product, or vegetative cover in a manner that will fully prevent soil erosion.
- Suggested BMPs (Refer to Chapter 3):
  - BMP C231: Brush Barrier
  - BMP C232: Gravel Filter Berm
  - BMP C233: Silt Fence
  - BMP C234: Vegetated Strip
  - BMP C235: Wattles

- BMP C240: Sediment Trap
- BMP C241: Temporary Sediment Pond
- BMP C250: Construction Stormwater Chemical Treatment
- BMP C251: Construction Stormwater Filtration
- Proprietary technologies exist that can be used for sediment control. The applicant can utilize any BMP that has been approved by Ecology via the Construction Technical Assessment Protocol Ecology program.

***Element #5: Stabilize Soils***

- Stabilize exposed and unworked soils by application of effective BMPs that protect the soil from the erosive forces of raindrop impact, flowing water, and wind.
- From October 1 through April 30, no soils shall remain exposed and unworked for more than 2 days. From May 1 to September 30, no soils shall remain exposed and unworked for more than 7 days. This stabilization requirement applies to all soils on site, whether at final grade or not.
- Stabilize soils at the end of the shift, before a holiday or weekend, if needed, based on the weather forecast.
- Select appropriate soil stabilization measures for the time of year, site conditions, estimated duration of use, and the potential water quality impacts that stabilization agents may have on downstream waters or groundwater.
- Stabilize soil stockpiles from erosion, protect stockpiles with sediment trapping measures, and where possible, locate piles away from storm drain inlets, waterways, and drainage channels.
- Control stormwater volume and velocity within the site to minimize soil erosion.
- Control stormwater discharges, including peak flow rates and total stormwater volume, to minimize erosion at outlets and to minimize downstream channel and stream bank erosion.
- Minimize the amount of soil exposed during construction activity.
- Minimize the disturbance of steep slopes.
- Minimize soil compaction and, unless infeasible, preserve topsoil.
- Ensure the gravel base used for stabilization is clean and does not contain fines or sediment.
- Suggested BMPs :(Refer to Chapter 3)
  - BMP C120: Temporary and Permanent Seeding
  - BMP C121: Mulching
  - BMP C122: Nets and Blankets
  - BMP C123: Plastic Covering
  - BMP C124: Sodding
  - BMP C125: Compost
  - BMP C126: Topsoiling

- BMP C127: Polyacrylamide for Soil Erosion Protection
- BMP C130: Surface Roughening
- BMP C131: Gradient Terraces
- BMP C140: Dust Control

**Element #6: Protect Slopes**

- Design and construct cut-and-fill slopes in a manner to minimize erosion. Applicable practices include, but are not limited to, reducing continuous length of slope with terracing and diversions, reducing slope steepness, and roughening slope surfaces (for example, track walking).
- Reduce slope runoff velocities by reducing continuous length of slope with terracing and diversions, reducing slope steepness, and/or roughing slope surface.
- Divert offsite stormwater (sometimes called run-on) away from slopes and disturbed areas with interceptor dikes and/or swales. Manage clean offsite stormwater separately from stormwater generated on the site.
- At the top of slopes, collect drainage in pipe slope drains or protected channels to prevent erosion. Size temporary pipe slope drains for the peak 10-minute flowrate from a 10 year, 24 hour event assuming a Type 1A rainfall distribution (3.0-inches). Alternatively, the 10-year return period flowrate, indicated by WWHM using a 15 minute timestep may be used. Use the existing land cover condition for predicting flow rates from tributary areas outside the project limits for the hydrologic analysis. For tributary areas on the project site, use the temporary or permanent project land cover condition, whichever will produce the higher flows for the analysis. If using WWHM to predict flows, model bare soils as landscaped areas.
- Provide drainage to remove groundwater seepage from the slope surface of exposed soil areas.
- Place excavated material on the uphill side of trenches, consistent with safety and space considerations.
- Place check dams at regular intervals within channels that are cut down a slope.
- Stabilize soils on slopes, as specified in Element #5.
- Construction on or near slopes 20% or greater may require evaluation by a geotechnical engineer.
- Suggested BMPs (Refer to Chapter 3):
  - BMP C120: Temporary and Permanent Seeding
  - BMP C121: Mulching
  - BMP C122: Nets and Blankets
  - BMP C130: Surface Roughening
  - BMP C131: Gradient Terraces
  - BMP C200: Interceptor Dike and Swale
  - BMP C201: Grass-Lined Channels
  - BMP C203: Water Bars



- BMP C204: Pipe Slope Drains
- BMP C205: Subsurface Drains
- BMP C206: Level Spreader
- BMP C207: Check Dams
- BMP C208: Triangular Silt Dike (Geotextile-Encased Check Dam)

**Element #7: Protect Drain Inlets**

- Protect all storm drain inlets that are operable during construction so that stormwater runoff does not enter the conveyance system without first being filtered or treated to remove sediment.
- Keep all approach roads clean. Do not allow sediment to enter storm drains.
- Inspect inlets weekly at a minimum and after each storm event. Clean or remove and replace inlet protection devices when sediment has filled one-third of the available storage (unless a different standard is specified by the product manufacturer).
- Suggested BMPs (Refer to Chapter 3):
  - BMP C220: Storm Drain Inlet Protection

**Element #8: Stabilize Channels and Outlets**

- Design, construct, and stabilize all temporary onsite conveyance channels to prevent erosion from the expected peak 10-minute flowrate of a 10-year, 24-hour storm event assuming a Type 1A rainfall distribution (3.0-inches) for the developed condition. Alternatively, the 10-year return period flowrate, indicated by WWHM assuming a 15 minute timestep may be used. For tributary areas outside the project limits, use the existing land cover conditions for predicting flow rates from tributary areas outside the project limits for the hydrologic analysis. For tributary areas on the project site, use the temporary or permanent project land cover condition, whichever will produce the highest flow rates, for the hydrologic analysis. If using WWHM, model bare soils as landscaped.
- Provide stabilization, including armoring material, adequate to prevent erosion of outlets, adjacent stream banks, slopes, and downstream reaches at the outlets of all conveyance systems.
- Suggested BMPs (Refer to Chapter 3):
  - BMP C122: Nets and Blankets
  - BMP C202: Channel Lining
  - BMP C207: Check Dams
  - BMP C209: Outlet Protection

**Element #9: Control Pollutants**

- Design, install, implement and maintain effective pollution prevention measures to minimize the discharge of pollutants.
- All discharges to the City sewer system (storm or sanitary sewers) require City approval. The approval may include a separate Special Approved Discharge (SAD) permit. Contact a City Source Control representative at 253-591-5588.

- Handle and dispose of all pollutants, including waste materials and demolition debris that occur on site during construction in a manner that does not cause contamination of stormwater.
- Provide cover, containment, and protection from vandalism for all chemicals, liquid products, petroleum products, and other materials that have the potential to pose a threat to human health and the environment. Provide secondary containment for tanks holding pollutants. Secondary containment means placing tanks or containers within an impervious structure capable of containing 110% of the volume contained in the largest tank within the containment structure. Double-walled tanks do not require additional secondary containment. If stormwater becomes polluted within the containment structure it must be managed appropriately based upon the pollutant of concern.
- Use spill prevention and control measures, such as drip pans, when conducting maintenance and repair of heavy equipment and vehicles involving oil changes, hydraulic system drain down, solvent and de-greasing cleaning operations, fuel tank drain down and removal, and other activities which may result in discharge or spillage of pollutants to the ground or into stormwater runoff. Clean contaminated surfaces immediately following any discharge or spill incident. Emergency repairs may be performed onsite using temporary plastic placed beneath and, if raining, over the vehicle.
- Discharge wheel wash or tire bath wastewater to a separate onsite treatment system that prevents discharge to surface water, such as closed-loop recirculation or upland applications, or to the sanitary sewer. Wheel wash, or tire bath wastewater shall not include wastewater from concrete washout areas.
- Only apply agricultural chemicals, including fertilizers and pesticides, when absolutely necessary and only in a manner and at application rates that will not result in loss of chemical to stormwater runoff. Follow manufacturers' recommendations for application rates and procedures.
- Use BMPs to prevent or treat contamination of stormwater runoff by pH modifying sources. These sources include, but are not limited to, bulk cement, cement kiln dust, fly ash, new concrete washing and curing waters, waste streams generated from concrete grinding and sawing, exposed aggregate processes, and concrete pumping and mixer washout waters. Construction site operators must adjust the pH of stormwater to prevent violations of water quality standards.
- Assure that washout of concrete trucks is performed offsite or in designated concrete washout areas only. Do not wash out concrete trucks onto the ground, or into storm drains, open ditches, streets, or streams. Do not dump excess concrete onsite except in designated concrete washout areas. Concrete spillage or concrete discharge to surface waters of the State is prohibited. Do not use upland land applications for discharging wastewater from concrete washout areas.
- Written approval from the Department of Ecology is required prior to using chemical treatment other than CO<sub>2</sub> or dry ice to adjust pH.
- Clean contaminated surfaces immediately following any discharge or spill incident.
- Suggested BMPs (Refer to Chapter 3):
  - BMP C151: Concrete Handling
  - BMP C152: Sawcutting and Surfacing Pollution Prevention
  - BMP C153: Material Delivery, Storage, and Containment
  - BMP C154: Concrete Washout Area

- BMP C250: Construction Stormwater Chemical Treatment
- BMP C251: Construction Stormwater Filtration
- BMP C252: High pH Neutralization Using CO<sub>2</sub>
- BMP C253: pH Control for High pH Water
- Source Control BMPs from Volume 4, as appropriate

**Element #10: Control Dewatering**

- All dewatering discharges to the City sewer system (storm or sanitary sewers) require City approval. The approval may include a separate Special Approved Discharge (SAD) permit. Contact a City Source Control Representative at 253-591-5588.
- Discharge foundation, vault, and trench dewatering water that has similar characteristics to site stormwater runoff into a controlled conveyance system prior to discharge to a sediment trap or sediment pond. Stabilize channels as specified in Element #8.
- Clean, non-turbid dewatering water, such as well-point groundwater, can be discharged to systems tributary to state surface waters, as specified in Element #8, provided the dewatering flow does not cause erosion or flooding of receiving waters. These clean waters should not be routed through stormwater sediment ponds/tanks.
- Handle highly turbid or contaminated dewatering water separately from stormwater at the site.
- Other disposal options, depending on site constraints, may include:
  - Infiltration, which may require approval from the Tacoma-Pierce County Health Department if located within the South Tacoma Groundwater Protection District.
  - Transport offsite in vehicle, such as a vacuum flush truck, for legal disposal in a manner that does not pollute state waters
  - Ecology approved onsite chemical treatment or other suitable treatment technologies
  - Use of a sedimentation bag that discharges to a ditch or swale for small volumes of localized dewatering
- Suggested BMPs (Refer to Chapter 3):
  - BMP C203: Water Bars
  - BMP C226: Vegetative Filtration
  - BMP C250: Construction Stormwater Chemical Treatment
  - BMP C251: Construction Stormwater Filtration

**Element #11: Maintain BMPs**

- Maintain and repair as needed all temporary and permanent erosion and sediment control BMPs to assure continued performance of their intended function. Conduct maintenance and repairs in accordance with BMP specifications.
- Remove temporary erosion and sediment control BMPs within 30 days after final site stabilization is achieved or after the temporary BMPs are no longer needed. Trapped sediment shall be removed or stabilized on site. Permanently stabilize disturbed soil resulting from removal of BMPs or vegetation.

- Include maintenance as a separate bid item for each BMP, where applicable.
- Suggested BMPs (Refer to Chapter 3):
  - BMP C150: Materials on Hand
  - BMP C160 Erosion and Sedimentation Control Lead

### ***Element #12: Manage the Project***

- ***Phasing of Construction*** – Phase development projects in order to prevent soil erosion and the transport of sediment from the project site during construction, unless the project engineer can demonstrate that construction phasing is infeasible. Revegetation of exposed areas and maintenance of that vegetation shall be an integral part of the clearing activities for any phase.
- ***Seasonal Work Limitations*** – From October 1 through April 30, clearing, grading, and other soil disturbing activities shall only be permitted if shown to the satisfaction of the City that silt-laden runoff will be prevented from leaving the site through a combination of the following:
  - Site conditions including existing vegetative coverage, slope, soil type, and proximity to receiving waters;
  - Limitations on activities and the extent of disturbed areas; and
  - Proposed erosion and sediment control measures.

Based on the information provided and local weather conditions, the City may expand or restrict the seasonal limitation on site disturbance. The following activities are exempt from the seasonal clearing and grading limitations:

- Routine maintenance and necessary repair of erosion and sediment control BMPs
- Routine maintenance of public facilities or existing utility structures that do not expose the soil or result in the removal of the vegetative cover to soil
- Activities where there is one hundred percent infiltration of surface water runoff within the site in approved and installed erosion and sediment control facilities
- ***Coordination with Utilities and Other Contractors*** – Include surface water management requirements for the entire project, including the utilities and other contractors, in the Construction SWPPP.
- ***Inspection and Monitoring***
  - a. Inspect, maintain, and repair all BMPs as needed to assure continued performance of their intended function.
  - b. Projects that disturb one or more acres must have site inspections conducted by a Certified Erosion and Sediment Control Lead (CESCL) or Certified Professional in Erosion and Sediment Control (CPESC).
  - c. Projects disturbing less than one acre must have an Erosion Sediment Control Lead (ESC) conduct inspections. The ESC Lead does not have to have CESCL or CPESC certification.
  - d. The CESCL, CPESC, or ESC Lead shall be identified in the SWPPP and shall be onsite or on-call at all times.

- e. The CESCL, CPESC, or ESC Lead must be knowledgeable in the principles and practices of erosion and sediment control and have the skills to assess:
  - Site conditions and construction activities that could impact the quality of stormwater.
  - Effectiveness of erosion and sediment control measures used to control the quality of stormwater discharges.
- f. The CESCL, CPESC, or ESC Lead must examine stormwater visually for the presence of suspended sediment, turbidity, discoloration, and oil sheen and evaluate the effectiveness of BMPs to determine if it is necessary to install, maintain, or repair BMPs.
- g. The CESCL, CPESC, or ESC Lead must inspect all areas disturbed by construction activities, all BMPs, and all stormwater discharge points at least once every calendar week and within 24 hours of any discharge from the site. (Individual discharge events that last more than one day do not require daily inspections). The CESCL, CPESC, or ESC Lead may reduce the inspection frequency for temporary stabilized, inactive sites to once every calendar month.
- h. Construction site operators must correct any problems identified by the CESCL, CPESC, or ESC Lead by:
  - Reviewing the SWPPP for compliance with the 13 construction SWPPP elements and making appropriate revisions within 7 days of the inspection.
  - Fully implementing and maintaining appropriate source control and/or treatment BMPs as soon as possible but correcting the problem within 10 days.
  - Documenting BMP implementation and maintenance in the site log book. (Required for sites larger than 1 acre but recommended for all sites).

Sampling and analysis of the stormwater discharges from a construction site may be necessary on a case-by-case basis to ensure compliance with standards. Ecology or the City will establish these monitoring and associated reporting requirements.

- **Responsible Party** – For all projects, a 24-hour responsible party shall be listed in the SWPPP, along with that person’s telephone number and email address.
- **Reporting** – Report spillage or discharge of pollutants within 24-hours to the City of Tacoma Source Control 24-hour phone number at (253) 502-2222.
- **Maintenance of the Construction SWPPP** – Keep the Construction SWPPP onsite or within reasonable access to the site. Modify the SWPPP whenever there is a change in the design, construction, operation, or maintenance at the construction site that has, or could have, a significant effect on the discharge of pollutants to waters of the state.

Modify the SWPPP if, during inspections or investigations conducted by the owner/operator, City staff, or by local or state officials, it is determined that the SWPPP is ineffective in eliminating or significantly minimizing pollutants in stormwater discharges from the site. Modify the SWPPP as necessary to include additional or modified BMPs designed to correct problems identified. Complete revisions to the SWPPP within seven (7) days following the inspection.

City of Tacoma Environment Services (review staff or inspector) may require that a modification to the SWPPP go through additional City review.

- Suggested BMPs (Refer to Chapter 3):
  - BMP C150: Materials on Hand
  - BMP C160: Erosion and Sediment Control Lead
  - BMP C162: Scheduling

***Element #13: Protect Permanent Stormwater BMPs***

- Protect all permanent stormwater BMPs from sedimentation through installation and maintenance of erosion and sediment control BMPs on portions of the site that drain into the BMPs. Restore all BMPs to their fully functioning condition if they accumulate sediment during construction. Sediment impacting Best Management Practices shall be removed before system start-up. Restoring the BMP shall include removal of all sediment.
- If sediment impacts bioretention or rain garden soil; any sediment-laden soil shall be removed and replaced in order to meet design specifications.
- Prevent compacting bioretention and rain garden BMPs by excluding construction equipment and foot traffic.
- Keep all heavy equipment off native soils under infiltration BMPs that have been excavated to final grade to retain the infiltration rate of the soils.
- Protect lawn and landscaped areas from compaction due to construction equipment.
- Do not allow muddy construction equipment on the base material of permeable pavement or on the permeable pavement section.
- Do not allow sediment laden runoff onto permeable pavements or base materials of permeable pavements.
- Permeable pavements fouled with sediment or that can no longer pass an initial infiltration test must be cleaned prior to final acceptance.
- See Chapter 5 of the Low Impact Development Technical Guidance for Puget Sound for additional information.
- Suggested BMPs (Refer to Chapter 3):
  - BMP C102: Buffer Zone
  - BMP C103: High Visibility Fence
  - BMP C200: Interceptor Dike and Swale
  - BMP C201: Grass-Lined Channels
  - BMP C207: Check Dams
  - BMP C208: Triangular Silt Dike (TSD) (Geotextile-Encased Check Dam)
  - BMP C231: Brush Barrier
  - BMP C232: Gravel Filter Berm

- BMP C233: Silt Fence
- BMP C234: Vegetated Strip
- BMP C235: Wattles

## **Chapter 2 Developing a Construction Stormwater Pollution Prevention Plan (SWPPP)**

This chapter provides an overview of the important components of, and the process for, developing and implementing a Construction Stormwater Pollution Prevention Plan (SWPPP).

### **2.1 General Requirements and Guidelines**

The Construction SWPPP is a document that describes the potential for pollution problems on a construction project. The Construction SWPPP explains and illustrates the measures to be taken on the construction site to control those problems.

All sites are required to comply with elements #1-#13.

Unless located in a critical area, a SWPPP is not required if all of the following are met:

- Add or replace less than 2000 square feet of impervious surface.
- Clear or disturb less than 7000 square feet of land.
- Grade/fill less than 50 cubic yards of material.

If the project quantities exceed any of the above thresholds, prepare a written SWPPP.

The Construction Stormwater Pollution Prevention Plan Short Form (Appendix B ) may be used for projects that:

- Add or replace between 2,000 and 5,000 square feet of impervious surface.
- Clear or disturb between 7000 square feet and 1 acre of land.
- Grade/fill between 50 and 499 cubic yards of material.

If the project quantities exceed any of the above thresholds, prepare a Long Form Construction SWPPP as described in this chapter.

A Long Form SWPPP is required for projects that meet any of the following thresholds:

- Add or replace 5000 square feet or greater of impervious surface, or,
- Disturb greater than 1 acre of land, or,
- Grade/Fill greater than 500 cubic yards of material.

The Construction SWPPP shall be prepared as a separate stand-alone document. Keep the Construction SWPPP on the construction site or within reasonable access to the site for construction and inspection personnel. As site work progresses, the plan must be modified to reflect changing site conditions. See Volume 1, Section 4.2.1 for plan revision requirements.

Include all 13 elements described in Volume 2, Chapter 1 in the Construction SWPPP unless an element is determined not to be applicable to the project and the exemption is justified in the narrative.

A Professional Engineer is required to complete SWPPPs that contain engineering calculations.



## 2.2 BMP Standards and Specifications

Chapter 3 of this volume contains standards and specifications for the BMPs referred to in this chapter. Wherever any of these BMPs are to be employed on a site, clearly reference the specific title and number of the BMP in the narrative and mark it on the drawings.

Where appropriate BMPs do not exist, experimental practices may be considered or minor modifications to standard practices may be employed. Such practices must be approved by the City before implementation.

The Washington State Department of Transportation (WSDOT) keeps a database of qualified erosion and sediment control BMPs and products. The City may allow the use of these BMPs and products when appropriate. They can be found at the following location:

<http://www.wsdot.wa.gov/Business/MaterialsLab/QPL.htm>

The Washington State Department of Ecology maintains a list of proprietary stormwater devices that are deemed equivalent to best management practices for stormwater pollution prevention at construction sites. Information concerning the equivalent products can be found at [www.ecy.wa.gov/programs/wq/stormwater/newtech/equivalent.html](http://www.ecy.wa.gov/programs/wq/stormwater/newtech/equivalent.html). The applicant may use these products if approved by the City of Tacoma.

## 2.3 Step-by-Step Procedure

There are three basic steps in producing a Construction SWPPP:

- Step 1 - Data Collection
- Step 2 - Data Analysis
- Step 3 - Construction SWPPP Development and Implementation

Steps 1 and 2, described in more detail below, are intended for projects that must complete a Long Form SWPPP. Smaller projects below the thresholds indicated in Section 2.1 General Requirements and Guidelines may prepare a short form Construction SWPPP (see Appendix B).

### 2.3.1 Step 1 – Data Collection

Evaluate existing site conditions and gather information that will help develop the most effective Construction SWPPP. The information gathered should be explained in the narrative and shown on the drawings. Appendix A provides standard notes required on the drawing.

- **Topography** - Prepare a topographic drawing of the site to show the existing contour elevations at intervals of 1 to 5 feet depending upon the slope of the terrain.
- **Drainage** - Locate and clearly mark existing drainage ditches, swales and patterns on the drawing, including existing storm drain pipe systems. Mark location of site runoff and runoff on drawing.
- **Soils** - Identify and label soil type(s) and erodibility (low, medium, high). A geotechnical investigation may be required since published soils information in the City is very limited. Regardless of the availability of published soils information, the project proponent is responsible for characterizing site soils for erosive potential.
- **Ground Cover** - Label existing vegetation on the drawing. Show such features as tree clusters, grassy areas, and unique or sensitive vegetation. Unique vegetation may include existing trees above a given diameter. The City of Tacoma encourages tree preservation where possible. Existing trees to be preserved shall be fenced and protected during construction activities per Tacoma Municipal Code 9.18.030, according to industry

standards (ANSI A300 Part 5) and the International Society of Arboriculture's Best Management Practices – Managing Trees During Construction. In addition, indicate existing denuded or exposed soil areas.

- **Critical Areas** - Delineate critical areas adjacent to or within the site on the drawing. Such features as steep slopes, streams, floodplains, lakes, wetlands, sole source aquifers, and geologic hazard areas, etc., should be shown. Critical areas identified by the City of Tacoma are available on the City's GovME website. Delineate setbacks and buffer limits for these features on the drawings. Other related jurisdictional boundaries such as Shorelines Management and the Federal Emergency Management Agency (FEMA) base floodplain should also be shown on the drawings. Tacoma Municipal Code 13.10 and 13.11 contain setback requirements for critical areas and shorelines.
- **Adjacent Areas** - Identify existing buildings, roads, and facilities adjacent to or within the project site on the drawings. Identify existing and proposed utility locations, construction clearing limits, and erosion and sediment control BMPs on the drawings.
- **Existing Encumbrances** - Identify wells, existing and abandoned septic drain fields, utilities, easements, and site constraints.
- **Precipitation Records** - Volume 3, Appendix A contains Tacoma's Design Storm Events. These can be used to help determine typical rainfall events for considering which BMPs are appropriate for your site.

### 2.3.2 Step 2 – Data Analysis

Consider the data collected in Step 1 to identify potential problems and limitations of the site. Determine those areas that have critical erosion hazards. The following are some important factors to consider in data analysis:

- **Topography** - The primary topographic considerations are slope steepness and slope length. The longer and steeper the slope, the greater the erosion potential. Erosion potential should be determined by a qualified engineer, soil professional, or certified erosion control specialist. Measures to decrease erosion potential shall be considered.
- **Drainage** - Natural drainage patterns that consist of overland flow, swales, and depressions should be used to convey runoff through the site to avoid construction of an artificial drainage system. Man-made ditches and waterways will become part of the erosion problem if they are not properly stabilized. Care should be taken to ensure that increased runoff from the site will not erode or flood the existing natural drainage system. Possible sites for temporary surface water retention and detention should be considered at this point.

Direct construction site runoff away from saturated soil areas where groundwater may be encountered and critical areas where drainage will concentrate. Preserve natural drainage patterns on the site.

- **Soils** - Evaluate soil properties such as surface and subsurface runoff characteristics, depth to impermeable layer, depth to seasonal groundwater table, permeability, shrink-swell potential, texture, settleability, and erodibility. Infiltration sites should be properly protected from clay and silt which will reduce infiltration capacities. Include any recommendations from geotechnical reports for handling construction stormwater runoff.
- **Ground Cover** - Ground cover is the most important factor in terms of preventing erosion. Existing vegetation that can be saved will prevent erosion better than constructed BMPs. Trees and other vegetation protect the soil structure. Disturb as little of the site as required to construct proposed improvements. If the existing vegetation cannot be saved, consider such practices as phasing of construction, temporary seeding,

and mulching. Phasing of construction involves stabilizing one part of the site before disturbing another. In this way, the entire site is not disturbed at once.

- **Critical Areas** - Critical areas may include flood hazard areas, mine hazard areas, slide hazard areas, sole source aquifers, wetlands, stream banks, fish-bearing streams, and other water bodies. Any critical areas within or adjacent to the development shall be a key consideration on land development decisions. Critical areas and their buffers delineated on the drawings shall be clearly flagged in the field. Critical areas identified by the City of Tacoma are available on the City's GovME website. Orange plastic fencing may be more useful than flagging to assure that equipment operators stay out of critical areas. Only unavoidable work should take place within critical areas and their buffers. Such unavoidable work will require special BMPs, permit restrictions, and mitigation plans. Additional requirements may be required by the Critical Areas Preservation Ordinance TMC 13.11 or the South Tacoma Groundwater Protection Ordinance, TMC 13.09.
- **Adjacent Areas** - An analysis of adjacent properties should focus on areas upslope and down slope from the construction project. Water bodies that will receive direct runoff from the site are a major concern. Investigate and identify runoff to the site. The types, values, and sensitivities of and risks to downstream resources, such as private property, stormwater facilities, public infrastructure, or aquatic systems, should be evaluated. Develop a plan to route runoff around areas disturbed by construction. Erosion and sediment controls should be selected accordingly.
- **Precipitation Records** - Volume 3, Appendix A contains Tacoma's Design Storm Events. These can be used to help determine typical rainfall events for considering which BMPs are appropriate for your site.
- **Timing of the Project** - An important consideration in selecting BMPs is the timing and duration of the project. Projects that will proceed during the wet season and projects that will last through several seasons must take all necessary precautions to remain in compliance with the SWMM.

### 2.3.3 Step 3 – Construction SWPPP Development and Analysis

The Construction SWPPP consists of two parts: a narrative and the drawings. This section describes the contents of the narrative and the drawings. This section is formatted as a checklist to aid the applicant and reviewer in development and review of the plan. Applicants are encouraged to complete and submit this form with their application. The Construction SWPPP shall be prepared as a stand-alone document.

The Department of Ecology has prepared a SWPPP template that offers a quick and convenient means for developing a SWPPP for development and redevelopment projects in the City of Tacoma. This template can be found on Ecology's website at:

<http://www.ecy.wa.gov/programs/wq/stormwater/construction/>

**NOTE:** Ensure that BMP numbers and references match the City SWMM when using the Ecology template. Remove any sections or language that do not pertain to the project site.

The following checklist provides a tool to the applicant to determine if all the major items are included in the Construction SWPPP. The checklist will be used by reviewers to determine that SWPPPs meet all requirements and are complete. Applicants are encouraged to complete and submit this form with their application.

## **Construction Stormwater Pollution Prevention Plan Checklist**

Project Name: \_\_\_\_\_

Address: \_\_\_\_\_

Parcel No.: \_\_\_\_\_

City Reference/Permit No.: \_\_\_\_\_

### **Section I – Construction SWPPP Narrative**

#### **1. Project Description**

The following topic headings shall be used, at a minimum, when preparing the Construction SWPPP narrative.

- Nature and purpose of project
- Total project area
- Total proposed impervious area
- Total proposed area to be disturbed
- Total volumes of proposed cut and fill
- Note if a NPDES Construction Stormwater General Permit is required. The online application is available at <http://www.ecy.wa.gov/programs/wq/stormwater/construction/enoi.html>

#### **2. Existing Site Conditions**

- Describe the existing topography
- Describe the existing vegetation
- Describe the existing drainage, including runoff and runoff
- Describe any existing development, including all structures and existing impervious
- Description of any easements or other encumbrances that may affect construction.

#### **3. Adjacent Areas and Drainage**

- Describe adjacent areas which may be affected by site disturbance, including streams, lakes, wetlands, residential areas, roads, drainage features, or any other areas
- Describe the downstream drainage path leading from the site to the receiving body of water (minimum distance of ¼ mile.)

#### **4. Critical Areas**

Critical areas identified by the City of Tacoma are available on the City's GovME website. Critical areas not identified on the website still require consideration.

- Describe critical areas, including the South Tacoma Groundwater Protection District, that are on or adjacent to the site, including those up to and within 1/4 mile. The distance may be increased by the City based on critical area.
- Describe special requirements for working in or near critical areas

## **Construction Stormwater Pollution Prevention Plan Checklist**

### **5. Soils**

- Describe on-site soils, include all relevant tests conducted.
  - Soil name(s)
  - Soil mapping unit
  - Groundwater elevation and seasonal high groundwater elevation

The following information may be required at the direction of Environmental Services:

- Erodibility
- Settleability
- Permeability
- Depth
- Texture
- Soil structure

### **6. Potential Erosion Problem Areas**

- Describe potential erosion problems on site

### **7. Construction Stormwater Pollution Prevention Elements**

- Describe how each of the Construction Stormwater Pollution Prevention Elements has been addressed.
- Identify the type and location of BMPs used to satisfy the required element.
- Written justification identifying the reason an element is not applicable to the proposal.

#### ***13 Required Elements - Construction Stormwater Pollution Prevention Plan:***

- 1. Preserve Vegetation and Mark Clearing Limits
- 2. Establish Construction Access
- 3. Control Flow Rates
- 4. Install Sediment Controls
- 5. Stabilize Soils
- 6. Protect Slopes
- 7. Protect Drain Inlets
- 8. Stabilize Channels and Outlets
- 9. Control Pollutants
- 10. Control Dewatering
- 11. Maintain BMPs
- 12. Manage the Project
- 13. Protect BMPs

### **8. Construction Phasing**

- Construction sequence
- Construction phasing (if proposed)

## **Construction Stormwater Pollution Prevention Plan Checklist**

### **9. Construction Schedule**

- Provide a proposed construction schedule.

### **10. Financial/Ownership Responsibilities**

- Identify the person responsible for ensuring proper erosion and sediment control.
- Identify the property owner responsible for the initiation of bonds and/or other financial securities.
- Describe bonds and/or other evidence of financial responsibility for liability associated with erosion and sedimentation impacts.
- Maintenance bond

### **11. Engineering Calculations**

- Provide Design Calculations. BMPs such as sediment ponds and traps, interceptor swales, and stormwater detention require engineering calculations. Provide electronic modeling files.
- Provide all assumptions and variables used in the design.
- Provide a signature and stamp from a Professional Engineer licensed in Washington State for all engineering calculations.

## **Construction Stormwater Pollution Prevention Plan Checklist**

### **Section II - Erosion and Sediment Control Drawings**

At a minimum, provide the following information and drawings as part of the Construction SWPPP erosion and sediment control plans. Include notes addressing construction phasing and scheduling on the drawings.

#### **1. General**

Provide a site map(s) showing the following features. The site map requirements may be met using multiple plan sheets for ease of legibility.

- Vicinity map with roads and waters of the state within one mile of the site
- Address, Parcel Number, and street names labels
- Erosion and Sediment Control Notes
- A legal description of the property boundaries or an illustration of property lines (including distances) in the drawings
- Project limits, including limits of construction and areas to remain undisturbed
- North arrow
- Existing structures and roads, if present
- Boundaries of soil types with labels
- Areas of potential erosion problems
- Points where surface water runs on and off the site
- Any onsite and adjacent surface waters, critical areas, their buffers, FEMA base flood boundaries, and Shoreline Management boundaries
- Existing contours, drainage pipes and ditches/swales, and drainage basins, and the direction of flow for the different drainage areas
- Final, and interim as appropriate, contours, drainage basins, and the direction of stormwater flow during and upon completion of construction
- Areas of soil disturbance, including all areas affected by clearing, grading, and excavation
- Locations where stormwater discharges to surface waters or the City system during and upon completion of construction
- Existing unique or valuable vegetation and the vegetation that is to be preserved
- Cut and fill slopes indicating top and bottom of slope catch lines
- Stockpile, waste storage, and vehicle storage/maintenance areas
- Total cut and fill quantities and the method of disposal for excess material
- All existing and proposed utilities and any associated easements
- Proposed structures including roads and parking areas
- Proposed infiltration facilities that may need protection
- Identify a responsible, certified erosion and sediment control lead (CESCL) as required  
Include the CESCL's telephone number and email address on drawings

## Construction Stormwater Pollution Prevention Plan Checklist

### 2. Temporary Conveyance Systems

Show on the site map(s) the following temporary and permanent onsite and offsite conveyance features:

- Locations for swales, interceptor trenches, or ditches
- Drainage pipes, ditches, or cut-off trenches associated with erosion and sediment control and stormwater management
- Temporary and permanent pipe inverts and minimum slopes and cover
- Grades, dimensions, and direction of flow in all ditches and swales, culverts, and pipes
- Details for bypassing offsite runoff or runoff around disturbed areas
- Locations and outlets of any dewatering systems

### 3. Location of Detention BMPs

- Identify the location of detention BMPs used for construction stormwater runoff.

### 4. Temporary Erosion and Sediment Control Facilities

Show on the site map all major structural and nonstructural TESC BMPs, including but not limited to:

- The location of sediment pond(s), pipes and structures
- Dimension pond berm widths and inside and outside pond slopes
- The trap/pond storage required and the depth, length, and width dimensions
- Typical section views through pond and outlet structure
- Typical details of gravel cone and standpipe, and/or other filtering devices
- Stabilization technique details for inlets and outlets
- Control/restrictor device location and details
- Stabilization practices, including details, for berms, slopes, and disturbed areas
- Rock specifications and detail for rock check dam, if used
- Spacing for rock check dams as required
- Front and side sections of typical rock check dams
- The location, detail, and specification for silt fence
- The construction entrance location and a detail

### 5. Detailed Drawings

- Explain and illustrate with detailed drawings any best management practices used that are not referenced in the SWMM.



## **Construction Stormwater Pollution Prevention Plan Checklist**

### **6. Other Pollutant BMPs**

- Indicate on the site plan the location of BMPs to be used for the control of pollutants other than sediment.

### **7. Monitoring Locations**

- Indicate on the site map the water quality sampling locations, if required by the City or the Department of Ecology. Sampling stations shall be located in accordance with applicable permit requirements.
- Describe inspection reporting responsibility, documentation, and filing.

## **Chapter 3 Standards and Specifications for Best Management Practices (BMPs)**

Best Management Practices (BMPs) are defined as schedules of activities, prohibitions of practices, maintenance procedures, and structural and/or managerial practices, that when used singly or in combination, prevent or reduce the release of pollutants to waters of Washington State. This chapter contains standards and specifications for temporary BMPs to be used as applicable during the construction phase of a project.

Section 3.1 contains the standards and specifications for Source Control BMPs specific to construction operations. Source Control BMPs prevent contamination from entering stormwater runoff by controlling them at the source.

Section 3.2 contains the standards and specifications for Runoff Conveyance and Treatment BMPs. Runoff Conveyance and Treatment BMPs are structural devices or facilities intended to prevent pollutants from entering the downstream system.

The standards for each individual BMP are divided into four sections:

1. Purpose
2. Conditions of Use
3. Design and Installation Specifications
4. Maintenance Standards

Note that the "Conditions of Use" always refers to site conditions. As site conditions change, BMPs must be changed to remain in compliance with Minimum Requirement #2.

Information on stream bank stabilization is available in the Integrated Streambank Protection Guidelines, Washington State Department of Fish and Wildlife, 2003.

### 3.1 Source Control BMPs

Table 2 - 1, below shows the relationship of some of the BMPs in Section 3.1 to the 13 Elements of a SWPPP. Elements not shown are not satisfied through source control BMPs.

**Table 2 - 1: Source Control BMPs by SWPPP Element**

BMP or Element Name	Element #1 Preserve Vegetation /Mark Clearing Limits	Element #2 Establish Construction Access	Element #5 Stabilize Soils	Element #6 Protect Slopes	Element #8 Stabilize Channel and Outlets	Element #9 Control Pollution	Element #11 Maintain BMP	Element #12 Manage the Project	Element #13 Protect BMPs
BMP C101 Preserving Natural Vegetation	X								
BMP C102 Buffer Zones	X								X
BMP C103 High Visibility Fencing	X								X
BMP C105 Stabilize Construction Entrance/Exit		X							
BMP C106 Wheel Wash		X							
BMP C107 Construction Road/Parking Area Stabilization		X							
BMP C120 Temporary and Permanent Seeding			X	X					
BMP C121 Mulching			X	X					
BMP C122 Nets and Blankets			X	X	X				
BMP C123 Plastic Covering			X						
BMP C125 Compost			X						
BMP C126 Topsoiling			X						

BMP or Element Name	Element #1 Preserve Vegetation /Mark Clearing Limits	Element #2 Establish Construction Access	Element #5 Stabilize Soils	Element #6 Protect Slopes	Element #8 Stabilize Channel and Outlets	Element #9 Control Pollution	Element #11 Maintain BMP	Element #12 Manage the Project	Element #13 Protect BMPs
BMP C130 Surface Roughening			X	X					
BMP C131 Gradient Terraces			X	X					
BMP C140 Dust Control			X						
BMP C150 Materials on Hand							X	X	
BMP C151 Concrete Handling						X			
BMP C152 Sawcutting and Surfacing Pollution Prevention						X			
BMP C153 Material Delivery, Storage, and Containment						X			
BMP C154 Concrete Washout Area						X			
BMP C160 Certified Erosion and Sediment Control Lead							X	X	
BMP C162 Scheduling								X	
BMP C233 Silt Fence	X								

### 3.1.1 BMP C101: Preserving Natural Vegetation

#### 3.1.1.1 Purpose

The purpose of preserving natural vegetation is to reduce erosion wherever practicable. Limiting site disturbance is the single most effective method for reducing erosion. For example, conifers

can hold up to about 50 percent of all rain that falls during a storm. Up to 20-30 percent of this rain may never reach the ground but is taken up by the tree or evaporates. Another benefit is that the rain held in the tree can be released slowly to the ground after the storm.

### **3.1.1.2 Conditions of Use**

Natural vegetation should be preserved on steep slopes, near perennial and intermittent watercourses or swales, in wooded areas, and any other location practicable.

Phase construction to preserve natural vegetation on the project site for as long as possible during construction.

### **3.1.1.3 Design and Installation Specifications**

Natural vegetation can be preserved in natural clumps or as individual trees, shrubs and vines.

The preservation of individual plants is more difficult because heavy equipment is generally used to remove unwanted vegetation. The points to remember when attempting to save individual plants are:

- Is the plant worth saving? Consider the location, species, size, age, vigor, and the work involved. The City of Tacoma encourages the preservation of native vegetation and trees, where practicable.
- Existing trees to be preserved shall be fenced and protected during construction activities per Tacoma Municipal Code 9.18.030, according to industry standards (ANSI A300 Part 5) and the International Society of Arboriculture's Best Management Practices – Managing Trees During Construction.

Trees and vegetation should be protected during construction per Tacoma Municipal Code 9.18.030, according to industry standards (ANSI A300 Part 5) and the International Society of Arboriculture's Best Management Practices – Managing Trees from Construction. Described below are the most common types of injury that occur to trees. The language is adapted from the International Society of Arboriculture's Best Management Practices – Managing Trees from Construction.

- Root cutting or damage which can be caused by excavation equipment, trenching equipment, burial of debris, fill over roots, and alterations made to the water table by grade changes.
- Soil compaction resulting from vehicle, equipment and foot traffic. Compacted soils permit less root growth and biological activity as a result of aeration, higher mechanical resistance to root penetration and slowed water movement.
- Mechanical injury to the tree. Trunks, roots, and tree crowns can be damaged by construction equipment. Injury can affect the ability of the tree or plant to transport water and nutrients, and removes the ability for the plant to protect against pathogens.
- Fill placed near the root collar can facilitate infection and encourage stem-girdling which will affect the long-term longevity of the tree or plant

### **3.1.1.4 Maintenance Standards**

- Inspect flagged and/or fenced areas regularly to make sure flagging or fencing has not been removed or damaged. If the flagging or fencing has been damaged or visibility reduced, it shall be repaired or replaced immediately and visibility restored.
- If tree roots have been exposed or injured, prune cleanly with an appropriate pruning saw or loppers directly above the damaged roots and recover with native soils.

### **3.1.2 BMP C102: Buffer Zone**

#### **3.1.2.1 Purpose**

An undisturbed area or strip of natural vegetation or an established suitable planting that will provide a living filter to reduce soil erosion and runoff velocities.

#### **3.1.2.2 Conditions of Use**

Natural buffer zones are used along streams, wetlands and other bodies of water that need protection from erosion and sedimentation. Vegetative buffer zones can be used to protect natural swales and can be incorporated into the natural landscaping of an area.

Critical-areas buffer zones should not be used as sediment treatment areas. Do not disturb critical area buffers. The City may expand the buffer widths temporarily to allow the use of the expanded area for removal of sediment.

#### **3.1.2.3 Design and Installation Specifications**

- Preserve natural vegetation or plantings in clumps, blocks, or strips as this is generally the easiest and most successful method. However, single specimen trees and plants should also be preserved.
- Leave all unstable slopes in their natural, undisturbed state.
- Mark clearing limits and keep all equipment and construction debris out of the natural areas. Steel construction fencing is the most effective method of protecting sensitive areas and buffers. Alternatively, wire-backed silt fence on steel posts is marginally effective. Flagging alone is typically not effective and will not be allowed.
- Keep all excavations and material storage areas outside the dripline of trees and shrubs.
- Do not push debris or extra soil into the buffer zone area because it will cause damage from burying and smothering.
- Vegetative buffer zones for streams, lakes or other waterways shall be established by the City or other state or federal permits or approvals.

#### **3.1.2.4 Maintenance Standards**

- Inspect the area frequently to make sure flagging and fencing remains in place and the area remains undisturbed.

### **3.1.3 BMP C103: High Visibility Fence**

#### **3.1.3.1 Purpose**

Fencing is intended to:

- Restrict clearing to approved limits.
- Prevent disturbance of sensitive areas, their buffers, and other areas required to be left undisturbed.
- Limit construction traffic to designated construction entrances or roads.
- Protect areas where marking with survey tape or flagging may not provide adequate protection.

#### **3.1.3.2 Conditions of Use**

To establish clearing limits, plastic or metal fence may be used:

- At the boundary of sensitive areas, their buffers, and other areas required to be left uncleared.
- As necessary to control vehicle access to and on the site.

### **3.1.3.3 Design and Installation Specifications**

- High visibility plastic fence shall be composed of a high-density polyethylene material and shall be at least four feet in height. Posts for the fencing shall be steel or wood and placed every 6 feet on center (maximum) or as needed to ensure rigidity. The fencing shall be fastened to the post every six inches with a polyethylene tie. On long continuous lengths of fencing, a tension wire or rope shall be used as a top stringer to prevent sagging between posts. The fence color shall be high visibility orange. The fence tensile strength shall be 360 lbs./ft. using the ASTM D4595 testing method.
- If appropriate, install fabric silt fence in accordance with BMP C233 to act as high visibility fence. Silt fence shall be at least 3 feet high and must be highly visible to meet the requirement of this BMP.
- Design and install metal fences according to the manufacturer's specifications.
- Metal fences shall be at least 3 feet high and must be highly visible.
- Do not wire or staple fences to trees.

### **3.1.3.4 Maintenance Standards**

- If the fence has been damaged or its visibility reduced, it shall be repaired or replaced immediately and visibility restored.

## **3.1.4 BMP C105: Stabilized Construction Entrance/Exit**

### **3.1.4.1 Purpose**

Construction entrances are stabilized to reduce the amount of sediment transported onto paved roads by vehicles or equipment by constructing a stabilized pad of quarry spalls at entrances and exits to construction sites.

### **3.1.4.2 Conditions of Use**

Construction entrances shall be stabilized wherever traffic will be leaving a construction site and traveling on paved roads or other paved areas within 1,000 feet of the site.

Construction vehicle ingress and egress shall be limited to one route. Additional routes may be allowed for very large projects or linear projects.

For residential construction provide stabilized construction entrances/exits for each residence. Stabilized surfaces shall be of sufficient length/width to provide vehicle access/parking based upon lot size and configuration. See Figure 2 - 2.

### **3.1.4.3 Design and Installation Specifications**

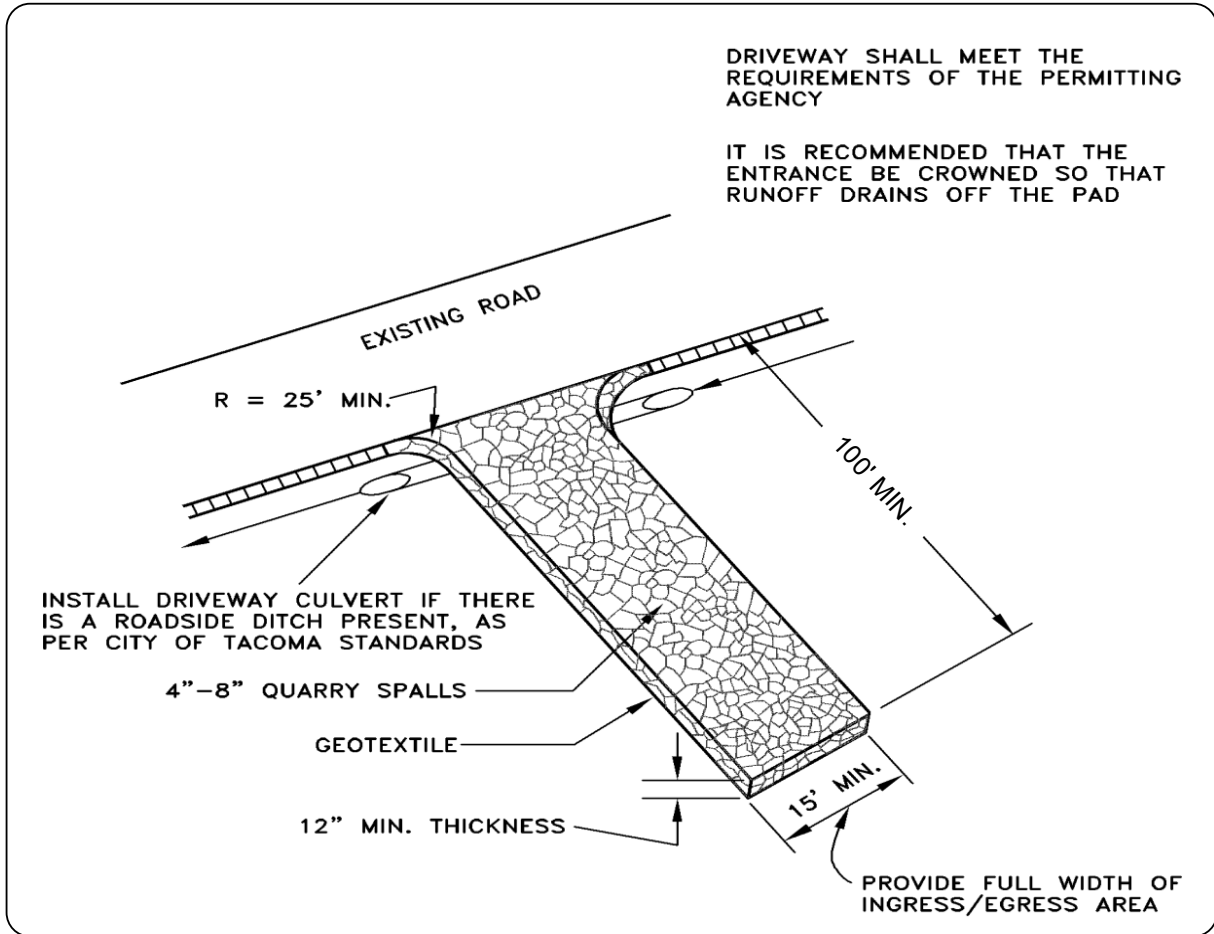
- See Figure 2 - 1 and Figure 2 - 2 for details. Reduce the length of the entrance to the maximum practicable size when the size or configuration of the site does not allow the full 100-foot length. Consult with the Erosion and Sediment Control Lead (ESCL) to determine if reducing the length of the entrance is acceptable.
- Construct stabilized construction entrance with a 12-inch thick pad of 4-inch to 8-inch quarry spalls, a 4-inch course of asphalt treated base (ATB), or using existing pavement. Protect permeable pavement surfaces per Element #13 as applicable. Do not use crushed concrete, cement, or calcium chloride for construction entrances stabilization.

- Place a separation geotextile under the spalls to prevent fine sediment from pumping up into the rock pad. The geotextile shall meet the following standards:
  - Grab Tensile Strength (ASTM D4751) – 200 psi min.
  - Grab Tensile Elongation (ASTM D4632) – 30% max.
  - Mullen Burst Strength (ASTM D3786-80a) – 400 psi min.
  - AOS (ASTM D4751) – 20 to 45 (U.S. standard sieve size)
- Consider early installation of the first lift of asphalt or extra concrete in areas that will be paved; this can be used as a stabilized entrance.
- Install fencing (see BMPs C103) as necessary to restrict traffic to the construction entrance.
- Whenever possible, construct the entrance on a firm, compacted subgrade. This can substantially increase the effectiveness of the pad and reduce the need for maintenance
- If possible, install the stabilized construction entrance on the uphill side of the site so that stormwater will not pond near the stabilized construction entrance.
- Construction entrance should avoid crossing existing sidewalks if possible. If a construction entrance must cross a sidewalk, the sidewalk must be covered and protected from sediment leaving the site.

#### **3.1.4.4 Maintenance Standards**

- Add quarry spalls if the pad is no longer in accordance with the specifications.
- If the entrance is not preventing sediment from being tracked onto pavement, then alternative measures to keep the streets free of sediment shall be used. This may include street sweeping, an increase in the dimensions of the entrance, or the installation of a wheel wash.
- No tracking of sediment onto the roadway is allowed. If sediment is tracked onto the road, immediately clean the road thoroughly by shoveling or pickup sweeping. Transport sediment to a controlled sediment disposal area.
- Perform street sweeping by hand or with a high efficiency sweeper. Do not use a non-high efficiency mechanical sweeper because this creates dust and throws soils into storm systems or conveyance ditches.
- Keep streets clean at ALL times. Clean tracked sediment immediately.
- Street washing of sediment to the storm drain system is not allowed.
- If sediment is discharged to the stormwater system it is the responsibility of the applicant to clean the downstream system.
- Immediately remove any quarry spalls that are loosened from the pad and end up on the roadway.
- Install fencing if vehicles are entering or exiting the site at points other than the construction entrance(s).
- Upon project completion and site stabilization, permanently stabilize all construction accesses intended as permanent access for maintenance.





**Figure 2 - 1. Stabilized Construction Entrance**

Figure 2 - 2 shows a small site, stabilized construction entrance.

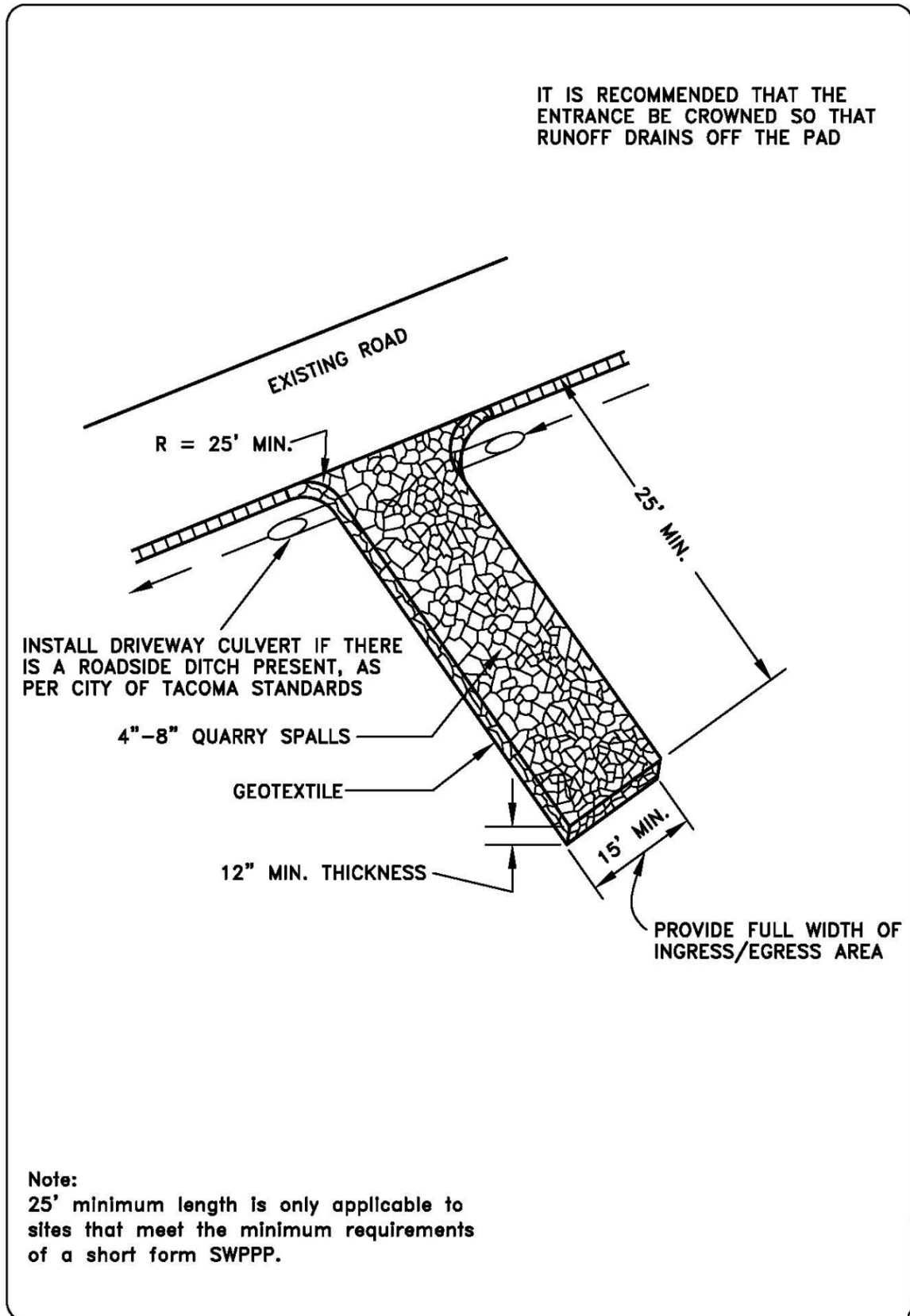


Figure 2 - 2. Small-Site Stabilized Construction Entrance

### **3.1.5 BMP C106: Wheel Wash**

#### **3.1.5.1 Purpose**

Wheel washes reduce the amount of sediment transported onto paved roads by motor vehicles.

#### **3.1.5.2 Conditions of Use**

- Can be used when a stabilized construction entrance (see BMP C105) is not preventing sediment from being tracked onto pavement.
- Wheel washing is generally an effective BMP when installed with careful attention to topography. For example, a wheel wash can be detrimental if installed at the top of a slope abutting a right-of-way where the water from the dripping truck can run unimpeded into the street.
- Pressure washing combined with an adequately sized and surfaced pad with direct drainage to a large 10-foot x 10-foot sump can be very effective.
- Discharge wheel wash or tire bath wastewater to a separate onsite treatment system that prevents discharge to surface water or to the wastewater system with a City of Tacoma Special Approved Discharge permit.
- Wheel wash or tire bath wastewater shall not include wastewater from concrete washout areas.

#### **3.1.5.3 Design and Installation Specifications**

- Suggested details are shown in Figure 2 - 3. The City may allow other designs. A minimum of 6 inches of asphalt treated base (ATB) over crushed base material or 8 inches over a good subgrade is recommended to pave the wheel wash.
- Use a low clearance truck to test the wheel wash before paving. Either a belly dump or lowboy will work well to test clearance.
- Keep the water level from 12 to 14 inches deep to avoid damage to truck hubs and filling the truck tongues with water.
- Midpoint spray nozzles are only needed in extremely muddy conditions.
- Design wheel wash systems with a small grade change, 6 to 12 inches for a 10-foot-wide pond, to allow sediment to flow to the low side of pond to help prevent re-suspension of sediment. A drainpipe with a 2- to 3-foot riser should be installed on the low side of the pond to allow for easy cleaning and refilling. Polymers may be used to promote coagulation and flocculation in a closed-loop system. Polyacrylamide (PAM) added to the wheel wash water at a rate of 0.25 - 0.5 pounds per 1,000 gallons of water increases effectiveness and reduces cleanup time. If PAM is already being used for dust or erosion control and is being applied by a water truck, the same truck can be used to change the wash water.

#### **3.1.5.4 Maintenance Standards**

- The wheel wash should start out the day with fresh water.
- The wash water should be changed as necessary with a minimum of once per day. On large earthwork jobs where more than 10-20 trucks per hour are expected, the wash water will need to be changed more often.
- Wheel wash or tire bath wastewater shall be discharged to a separate onsite treatment system, such as closed-loop recirculation or land application, or to the sanitary sewer with a City of Tacoma Special Approved Discharge permit.

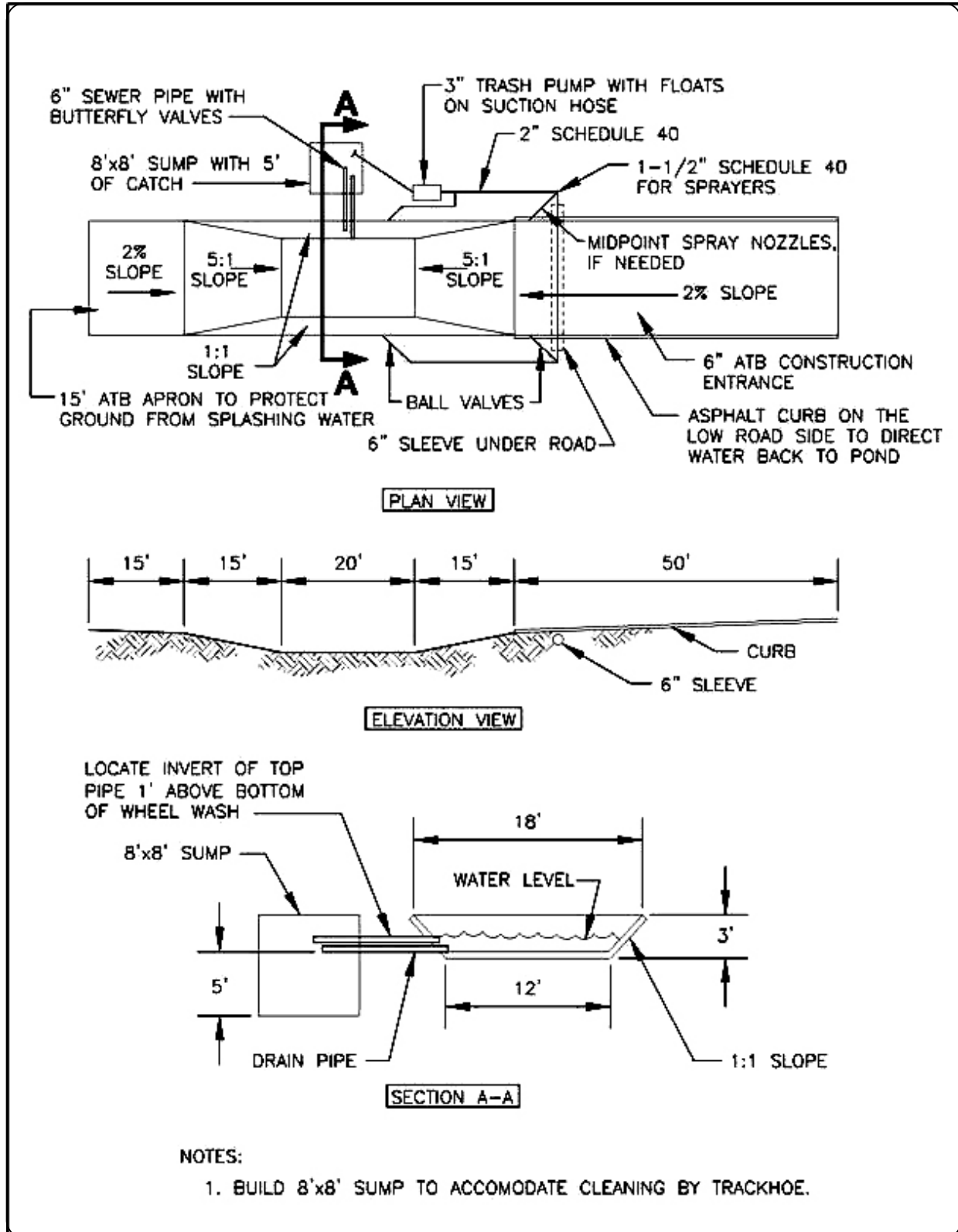


Figure 2 - 3. Wheel Wash

### **3.1.6 BMP C107: Construction Road/Parking Area Stabilization**

#### **3.1.6.1 Purpose**

Stabilizing subdivision roads, parking areas and other onsite vehicle transportation routes immediately after grading reduces erosion caused by construction traffic or runoff.

#### **3.1.6.2 Conditions of Use**

- Stabilize roads or parking areas wherever they are constructed, whether permanent or temporary, for use by construction traffic.
- Install fencing (see BMPs C103), if necessary, to limit the access of vehicles to only those roads and parking areas that are stabilized.

#### **3.1.6.3 Design and Installation Specifications**

- On areas that will receive asphalt as part of the project, install the first lift as soon as possible.
- Use one of the following methods to stabilize the area immediately after grading or utility installation.
  - Pave the road/parking area.
  - Apply 6-inch depth of 2- to 4-inch crushed rock, gravel base, or crushed surfacing base course.
  - Apply a 4-inch course of asphalt treated base (ATB).
  - Apply cement or calcium chloride<sup>1</sup>.
  - Apply a 6-inch depth of hog fuel (only if the area will not be used for permanent roads, parking areas or structures).
- Whenever possible, place construction roads and parking areas on a firm, compacted subgrade.
- Temporary road gradients shall not exceed 15 percent. Carefully grade roadways to drain. Provide drainage ditches on each side of the roadway in the case of a crowned section, or on one side in the case of a super-elevated section. Direct drainage ditches to a sediment control BMP.
- Rather than relying on ditches, it may also be possible to grade the road so that runoff sheet flows into a heavily vegetated area with a well-developed topsoil. Landscaped areas are not adequate. If this area has at least 50 feet of vegetation, then it is generally preferable to use the vegetation to treat runoff, rather than a sediment pond or trap. The 50 feet shall not include wetlands. If runoff is allowed to sheetflow through adjacent vegetated areas, it is vital to design the roadways and parking areas so that no concentrated runoff is created.
- Protect storm drain inlets to prevent sediment-laden water entering the storm drain system (see BMP C220).

---

1.If cement or cement kiln dust is used for roadbase stabilization, pH monitoring and BMPs are necessary to evaluate and minimize the effects on stormwater.

### **3.1.6.4 Maintenance Standards**

- Inspect stabilized areas regularly, especially after large storm events.
- Add crushed rock, gravel base, hog fuel, etc. as required to maintain a stable driving surface and to stabilize any eroded areas.
- Following construction, restore all areas to preconstruction condition or better to prevent future erosion.
- No tracking of sediment onto the roadway is allowed. If sediment is tracked onto road, clean the road thoroughly by shoveling or pickup sweeping.

### **3.1.7 BMP C120: Temporary and Permanent Seeding**

#### **3.1.7.1 Purpose**

Seeding reduces erosion by stabilizing exposed soils. A well-established vegetative cover is one of the most effective methods of reducing erosion.

#### **3.1.7.2 Conditions of Use**

- Seeding may be used throughout the project on disturbed areas that have reached final grade or that will remain unworked.
- Channels that will be vegetated should be installed before major earthwork and hydroseeded with a Bonded Fiber Matrix. The vegetation should be well established (i.e., 75 percent cover) before water is allowed to flow in the ditch. With channels that will have high flows, install erosion control blankets over the hydroseed. If vegetation cannot be established from seed before water is allowed in the ditch, sod should be installed in the bottom of the ditch over hydromulch and blankets.
- Seed detention ponds as required.
- Mulch is required at all times because it protects seeds from heat, moisture loss, and transport due to runoff.

Mulch can be applied on top of the seed or simultaneously by hydroseeding. See BMP C121: Mulching for specifications.

- All disturbed areas shall be reviewed in late August to early September and all seeding shall be completed by the end of September. Otherwise, vegetation will not establish itself enough to provide more than average protection.
- At final site stabilization, seed and mulch all disturbed areas not otherwise vegetated or stabilized. Final stabilization means the completion of all soil disturbing activities at the site and the establishment of a permanent vegetative cover, or equivalent permanent stabilization measures (such as pavement, riprap, gabions or geotextiles) which will prevent erosion.

#### **3.1.7.3 Design and Installation Specifications**

- Seed during seasons most conducive to plant growth.
  - The optimum seeding windows for western Washington are April 1 through June 30 and September 1 through October 1.
  - Seeding that occurs between July 1 and August 30 will require irrigation until 75 percent grass cover is established.

- Seeding that occurs between October 1 and March 30 will require a mulch or straw cover until 75 percent grass cover is established.
- Deviation from these specifications will be allowed if alternatives are developed by a licensed Landscape Professional and approved by the City.
- To prevent seed from being washed away, confirm that all required surface water control measures have been installed.
- The seedbed should be firm and rough. All soil should be roughened no matter what the slope. If compaction is required for engineering purposes, track walk slopes before seeding. Backblading or smoothing of slopes greater than 4:1 is not allowed if they are to be seeded.
- New and more effective restoration-based landscape practices rely on deeper incorporation than that provided by a simple single-pass rototilling treatment. Wherever practical, the subgrade should be initially ripped to improve long-term permeability, infiltration, and water inflow qualities. At a minimum for permanent areas, use soil amendments to achieve organic matter and permeability performance defined in engineered soil/landscape systems. For systems that are deeper than 8 inches, complete the rototilling process in multiple lifts, or prepare the soil system properly and then place it to achieve the specified depth.
- The use of fertilizers is discouraged. Fertilizers should only be used where necessary to ensure growth. Amending soils per BMPL613 should be considered (and may be required for permanent lawn and landscaped areas) as the first measure for ensuring vegetation growth. If fertilization is necessary, naturally-derived fertilizers should be chosen over chemically-derived fertilizers. Apply fertilizers per manufacturer's direction. Always use slow-release fertilizers.
- Hydroseed applications shall include a minimum of 1,500 pounds per acre of mulch with 3 percent tackifier. See BMP C121: Mulching for specifications.
- On steep slopes, Bonded Fiber Matrix (BFM) or Mechanically Bonded Fiber Matrix (MBFM) products should be used. BFM/MBFM products are applied at a minimum rate of 3,000 pounds per acre of mulch with approximately 10 percent tackifier. Application is made so that a minimum of 95 percent soil coverage is achieved. Numerous products are available commercially and should be installed per manufacturer's instructions. Most products require 24-36 hours to cure before a rainfall and cannot be installed on wet or saturated soils. Generally, these products come in 40-50 pound bags and include all necessary ingredients except for seed and fertilizer.
- BFMs and MBFMs have some advantages over blankets:
  - No surface preparation required;
  - Can be installed via helicopter in remote areas;
  - On slopes steeper than 2.5:1, blanket installers may need to be roped and harnessed for safety;
- In most cases, the shear strength of blankets is not a factor when used on slopes, only when used in channels. BFMs and MBFMs are good alternatives to blankets in most situations where vegetation establishment is the goal.
- When installing seed via hydroseeding operations, only about 1/3 of the seed actually ends up in contact with the soil surface. This reduces the ability to establish a good stand of grass quickly. One way to overcome this is to increase seed quantities by up to 50 percent.

- Vegetation establishment can also be enhanced by dividing the hydromulch operation into two phases:
  - Phase 1- Install all seed and fertilizer with 25-30 percent mulch and tackifier onto soil in the first lift;
  - Phase 2- Install the rest of the mulch and tackifier over the first lift.
- An alternative is to install the mulch, seed, fertilizer, and tackifier in one lift. Then, spread or blow straw over the top of the hydromulch at a rate of about 800-1000 pounds per acre. Hold straw in place with a standard tackifier. Both of these approaches will increase cost moderately but will greatly improve and enhance vegetative establishment. The increased cost may be offset by the reduced need for:
  - Irrigation
  - Reapplication of mulch
  - Repair of failed slope surfaces
  - This technique works with standard hydromulch (1,500 pounds per acre minimum) and BFM/MBFMs (3,000 pounds per acre minimum).
- Provide a healthy topsoil to areas to be permanently landscaped. This will reduce the need for fertilizers, improve overall topsoil quality, provide for better vegetal health and vitality, improve hydrologic characteristics, and reduce the need for irrigation. See the Post-Construction Soil Quality and Depth BMP in Volume 6 for more information. Compost shall meet specification in Volume 5, Appendix E. City of Tacoma Tagro Potting Soil can be used as an alternative to the compost component. Areas that will be seeded only and not landscaped may need compost or meal-based mulch included in the hydroseed in order to establish vegetation. Replace native topsoil on the disturbed soil surface before application.
- Seed that is installed as a temporary measure may be installed by hand if it will be covered by straw, mulch, or topsoil. Seed that is installed as a permanent measure may be installed by hand on small areas (usually less than 1 acre) that will be covered with mulch, topsoil, or erosion blankets.
- The seed mixes listed below include recommended mixes for both temporary and permanent seeding. These mixes, with the exception of the wetland mix, shall be applied at a rate of 120 pounds per acre. This rate can be reduced if soil amendments or slow-release fertilizers are used. Local suppliers or the local conservation district should be consulted for their recommendations because the appropriate mix depends on a variety of factors, including location, exposure, soil type, slope, and expected foot traffic. Alternative seed mixes approved by the City of Tacoma may be used.
- Table 2 - 2 represents the standard mix for those areas where just a temporary vegetative cover is required.
- Table 2 - 3 provides one recommended possibility for landscaping seed.
- The turf seed mix in Table 2 - 4 is for dry situations. The advantage is that this mix requires very little maintenance.
- Table 2 - 5 presents a mix recommended for bioswales and other intermittently wet areas.
- The seed mix shown in Table 2 - 6 is a recommended low-growing, relatively non-invasive seed mix appropriate for very wet areas that are not regulated wetlands. Other mixes may be appropriate, depending on the soil type and hydrology of the area. Recent



research suggests that bentgrass (*agrostis* sp.) should be emphasized in wet-area seed mixes. Apply this mixture at a rate of 60 pounds per acre.

- The meadow seed mix in Table 2 - 7 is recommended for areas that will be maintained infrequently or not at all and where colonization by native plants is desirable. Likely applications include rural road and utility right-of-way. Seeding should take place in September or very early October in order to obtain adequate establishment prior to the winter months. The appropriateness of clover in the mix may need to be considered, as this can be a fairly invasive species. If the soil is amended, the addition of clover may not be necessary.

**3.1.7.4 Maintenance Standards**

- Reseed any seeded areas that fail to establish at least 80 percent cover within 6 weeks from the initial seeding (100 percent cover for areas that receive sheet or concentrated flows). If reseeding is ineffective, use an alternate method, such as sodding, mulching, or nets/blankets. If winter weather prevents adequate grass growth, this time limit may be relaxed at the discretion of the City.
- After adequate cover is achieved, reseed and protect with mulch any areas that experience erosion. If the erosion problem is drainage related, the problem shall be fixed and the eroded area reseeded and protected by mulch.
- Water seeded areas if necessary. Watering shall not cause runoff.

**Table 2 - 2: Temporary Erosion Control Seed Mix**

	% Weight	% Purity	% Germination
Chewings or annual bluegrass <i>Festuca rubra</i> var. <i>commutate</i> or <i>Poa anna</i>	40	98	90
Perennial rye <i>Lolium perenne</i>	50	98	90
Redtop or colonial bentgrass <i>Agrostis alba</i> or <i>Agrostis tenuis</i>	5	92	85
White Dutch clover <i>Trifolium repens</i>	5	98	90

**Table 2 - 3: Landscaping Seed Mix**

	% Weight	% Purity	% Germination
Perennial rye <i>Lolium perenne</i>	70	98	90
Chewings and red fescue blend <i>Festuca rubra</i> var <i>commutate</i> or <i>Festuca rubra</i>	30	98	90

**Table 2 - 4: Low-Growing Turf Seed Mix**

	% Weight	% Purity	% Germination
Dwarf tall fescue (several varieties) <i>Festuca arundinacea</i> var.	45	98	90
Dwarf perennial rye (Barclay) <i>Lolium perenne</i> var. <i>barclay</i>	30	98	90
Red fescue <i>Festuca rubra</i>	20	98	90
Colonial bentgrass <i>Agrostis tenuis</i>	5	98	90

**Table 2 - 5: Bioswale Seed Mix<sup>a</sup>**

	% Weight	% Purity	% Germination
Tall or meadow fescue <i>Festuca arundinacea</i> or <i>Festuca elatior</i>	75-80	98	90
Seaside/Creeping bentgrass <i>Agrostis palustris</i>	10-15	92	95
Redtop bentgrass <i>Agrostis alba</i> or <i>Agrostis gigantea</i>	5-10	90	90

a. Modified Briargreen, Inc. Hydroseeding Guide Wetlands Seed Mix

**Table 2 - 6: Wet Area Seed Mix**

	% Weight	% Purity	% Germination
Tall or meadow fescue <i>Festuca arundinacea</i> or <i>Festuca elatior</i>	60-70	98	90
Seaside/Creeping bentgrass <i>Agrostis palustris</i>	10-15	98	85
Meadow foxtail <i>Alephocurus pratensis</i>	10-15	90	80
Alsike clover <i>Trifolium hybridum</i>	1-6	98	90
Redtop bentgrass <i>Agrostis alba</i> or <i>Agrostis gigantea</i>	1-6	92	85

**Table 2 - 7: Meadow Seed Mix**

	% Weight	% Purity	% Germination
Redtop or Oregon bentgrass <i>Agrostis alba</i> or <i>Agrostis oregonensis</i>	20	92	85
Red fescue <i>Festuca rubra</i>	70	98	90
White Dutch clover <i>Trifolium repens</i>	10	98	90

### **3.1.8 BMP C121: Mulching**

#### **3.1.8.1 Purpose**

The purpose of mulching soils is to provide immediate temporary protection from erosion. Mulch also enhances plant establishment by conserving moisture, holding fertilizer, seed, and topsoil in place, and moderating soil temperatures. Only the most common types are discussed in this section.

#### **3.1.8.2 Conditions of Use**

As a temporary cover measure, mulch should be used:

- On disturbed areas that require cover measures for less than 30 days.
- As a cover for seed.
- During the wet season on slopes steeper than 3H:1V with more than 10 feet of vertical relief.
- Mulch may be applied at any time of the year and must be refreshed periodically.

#### **3.1.8.3 Design and Installation Specifications**

- Mulch shall be compost, chipped site vegetation, hydro-mulch, wood-based mulch or wood straw, wood strand mulch, or straw. The City of Tacoma may also accept products approved as equivalent by the Washington State Department of Ecology - <http://www.ecy.wa.gov/programs/wq/stormwater/newtech/> and those listed on the WSDOT Qualified Product List that meet the specifications below. See Table 2 - 8 for specifications, application rates, and additional information.
- A minimum of 2" of mulch is required. Increase the mulch thickness until the ground is 95% covered (not visible under the mulch). Thickness may need to increase for disturbed areas in or near sensitive or other areas susceptible to erosion.
- Mulch used within the ordinary high-water mark of surface waters should be selected to minimize potential flotation of organic matter. Compost has a higher specific gravities (densities) than straw, wood, or chipped material.

#### **3.1.8.4 Maintenance Standards**

- The thickness of the cover must be maintained.
- Remulch and/or protect with a net or blanket any areas that experience erosion. If the erosion problem is drainage related, then fix the problem and remulch the eroded area.

**Table 2 - 8: Mulch Standards and Guidelines**

Compost											
<ul style="list-style-type: none"> <li>• Compost shall:                             <ul style="list-style-type: none"> <li>◦ Meet the definition for “composted material” per WAC 173-350-100 and comply with standards in WAC 173-350-220, except the feedstock may contain biosolids or manure feedstocks.</li> <li>◦ Be coarse compost meeting the following size gradations (by dry weight) when tested in accordance with the U.S. Composting Council “Test Methods for the Examination of Compost and Composting” (TMECC) Test Method 02.02-B.</li> </ul> </li> </ul>											
<table border="1"> <thead> <tr> <th>Sieve Size</th> <th>Minimum Percent Passing</th> </tr> </thead> <tbody> <tr> <td style="text-align: center;">3”</td> <td style="text-align: center;">100</td> </tr> <tr> <td style="text-align: center;">1”</td> <td style="text-align: center;">90</td> </tr> <tr> <td style="text-align: center;">3/4”</td> <td style="text-align: center;">70</td> </tr> <tr> <td style="text-align: center;">1/4”</td> <td style="text-align: center;">40</td> </tr> </tbody> </table>		Sieve Size	Minimum Percent Passing	3”	100	1”	90	3/4”	70	1/4”	40
Sieve Size	Minimum Percent Passing										
3”	100										
1”	90										
3/4”	70										
1/4”	40										
<ul style="list-style-type: none"> <li>◦ Have no visible water or dust during handling.</li> <li>◦ Have soil organic matter content of 40% to 65%.</li> <li>◦ Have a carbon to nitrogen ratio below 25:1. Carbon to nitrogen ratio may be as high as 35:1 for plantings composed entirely of plants native to the Puget Sound Lowlands region.</li> <li>◦ Be applied a minimum of 2” thick (~100 tons/acre) though thicker application rates may provide more effective control.</li> </ul>											
<ul style="list-style-type: none"> <li>• Do not use near wetlands or phosphorus impaired waterbodies.</li> <li>• Compost can be later tilled into soils to help meet the requirements of BMP L613 – Post-Construction Soil Quality and Depth as required per Minimum Requirement #5.</li> </ul>											
<p>Compost specifications are also contained in Vol 5, Appendix E.</p>											
Chipped Site Vegetation											
<ul style="list-style-type: none"> <li>• Chipped site vegetation shall:                             <ul style="list-style-type: none"> <li>◦ Have an average size of 2-4” with gradations from fine to 6” in length for texture, variation, and interlocking properties.</li> <li>◦ Be applied a minimum of 2” thick.</li> </ul> </li> <li>• Do not apply on slopes greater than 10%.</li> <li>• Do not use within 200 feet of surface waterbodies.</li> <li>• Using chipped site vegetation is a cost-effective way to dispose of debris associated with clearing and grubbing material. The decomposition of the chipped vegetation may help impart nutrients for grass establishment.</li> </ul>											

**Table 2 - 8: Mulch Standards and Guidelines**

Hydro-mulch
<ul style="list-style-type: none"> <li>• Hydro-mulch shall:                             <ul style="list-style-type: none"> <li>◦ Be applied with seed and tackifier.                                     <ul style="list-style-type: none"> <li>• May be applied without seed and tackifier if application rate is doubled.</li> </ul> </li> <li>◦ Have no growth inhibiting factors.</li> <li>◦ Have fibers less than ¾” in length to ensure machinery does not clog.</li> <li>◦ Be applied at 25-30 pounds per ft<sup>2</sup> or 1500-2000 pounds per acre with a hydromulcher.</li> </ul> </li> </ul>
Wood-based Mulch or Wood Straw
<ul style="list-style-type: none"> <li>• Wood-based mulch or straw mulch shall:                             <ul style="list-style-type: none"> <li>◦ Have no visible water or dust during handling.</li> <li>◦ Be purchased from a supplier with a Solid Waste Handling Permit or a supplier that is exempt from solid waste regulations.</li> <li>◦ Be applied 2” thick (~100 tons/acre)</li> </ul> </li> <li>• Wood-based mulch or wood straw is often called “hog” or “hogged fuel”.</li> <li>• The preparation of wood-based mulch typically does not account for weed seed control so the inclusion of weed plants or seeds should be monitored and minimized or prevented during application.</li> </ul>
Wood Strand Mulch
<ul style="list-style-type: none"> <li>• Wood strand mulch shall be:                             <ul style="list-style-type: none"> <li>◦ A blend of loose long, thin wood pieces derived from native conifers or deciduous trees with high length-width ratio.</li> <li>◦ A minimum of 95% of the wood strand shall have lengths between 2” and 10” with a width and thickness between 1/16” and 3/8”.</li> <li>◦ Free of resin, tannin, or other compounds that are detrimental to plant establishment and growth.</li> <li>◦ Applied 2” thick.</li> </ul> </li> <li>• Do not use sawdust or wood shavings.</li> </ul>

**Table 2 - 8: Mulch Standards and Guidelines**

Straw
<ul style="list-style-type: none"><li>• Straw shall be:<ul style="list-style-type: none"><li>◦ Air-dried.</li><li>◦ Free from undesirable seed and coarse material.</li><li>◦ Applied 2”-3” thick (5 bales per 1000 ft<sup>2</sup> or 2-3 tons per acre)<ul style="list-style-type: none"><li>• Thickness may be reduced by half when used with seeding.</li><li>• Hand-application requires a greater thickness than blown straw to ensure required coverage.</li></ul></li><li>◦ Held in place by crimping, using a tackifier, or covering with netting. Blown straw shall be held in place using a tackifier.</li></ul></li><li>• Although straw can be cost-effective, straw can introduce and/or encourage weed species and has no long-term benefits so should only be used when other materials are unavailable.</li><li>• Do not use within the ordinary high-water elevation of surface waters (due to flotation).</li></ul>

### **3.1.9 BMP C122: Nets and Blankets**

#### **3.1.9.1 Purpose**

Erosion control nets and blankets are intended to prevent erosion and hold seed and mulch in place on steep slopes and in channels so that vegetation can become well established. In addition, some nets and blankets can be used to permanently reinforce turf to protect drainage ways during high flows. Nets (commonly called matting) are strands of material woven into an open, but high-tensile strength net (for example, coconut fiber matting). Blankets are strands of material that are not tightly woven, but instead form a layer of interlocking fibers, typically held together by a biodegradable or photodegradable netting (for example, excelsior or straw blankets). They generally have lower tensile strength than nets, but cover the ground more completely. Coir (coconut fiber) fabric comes as both nets and blankets.

#### **3.1.9.2 Conditions of Use**

Erosion control nets and blankets should be used:

- To aid permanent vegetated stabilization of slopes 2H:1V or greater and with more than 10 feet of vertical relief.
- For drainage ditches and swales (highly recommended). The application of appropriate netting or blanket to drainage ditches and swales can protect bare soil from channelized runoff while vegetation is established. Nets and blankets also can capture a great deal of sediment due to their open, porous structure. Synthetic nets and blankets can be used to permanently stabilize channels and may provide a cost-effective, environmentally preferable alternative to riprap. 100 percent synthetic blankets manufactured for use in ditches may be easily reused as temporary ditch liners.
- Disadvantages of blankets include:
  - Surface preparation required;
  - On slopes steeper than 2.5:1, blanket installers may need to be roped and harnessed for safety;
- Advantages of blankets include:
  - Can be installed without mobilizing special equipment;
  - Can be installed by anyone with minimal training;
  - Can be installed in stages or phases as the project progresses;
  - Seed and fertilizer can be hand-placed by the installers as they progress down the slope;
  - Can be installed in any weather;
  - There are numerous types of blankets that can be designed with various parameters in mind. Those parameters include: fiber blend, mesh strength, longevity, biodegradability, cost, and availability.

#### **3.1.9.3 Design and Installation Specifications**

- See Figure 2 - 4 and Figure 2 - 5 for typical orientation and installation of blankets used in channels and as slope protection. Note: these are typical only; all blankets must be installed per manufacturer's installation instructions.

- Installation is critical to the effectiveness of these products. If good ground contact is not achieved, runoff can concentrate under the product, resulting in significant erosion.

### ***Installation of Blankets on Slopes:***

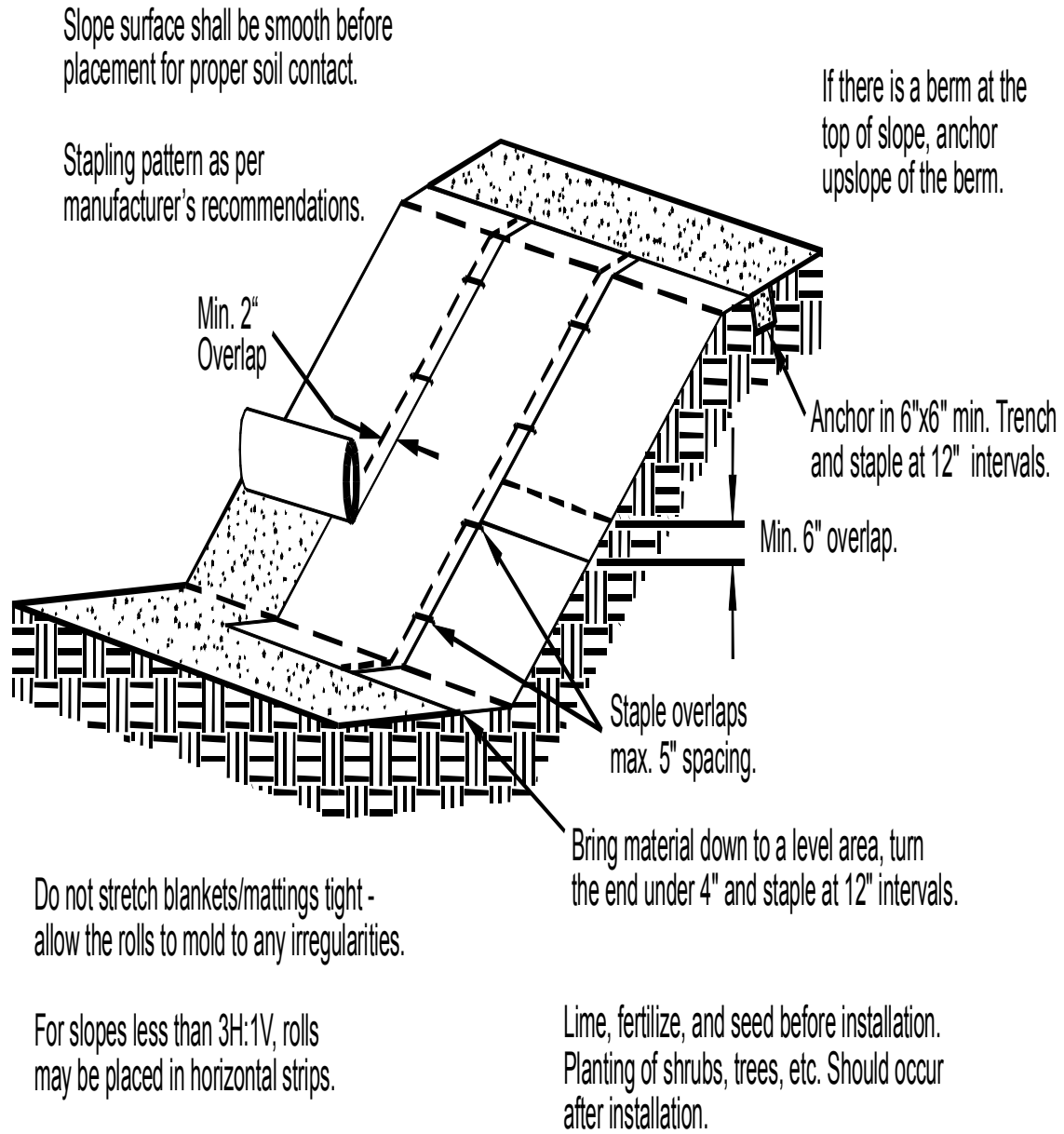
- Complete final grade and track walk up and down the slope.
- Slope surface shall be free of rocks, clods, sticks and grass. Nets/blankets shall have good contact with the soil.
- Apply permanent seeding per BMP C120 or mulching per BMP C121 before placing net/blanket.
- Dig a small trench, approximately 12 inches wide by 6 inches deep along the top of the slope. Cover with soil to secure.
- Install the leading edge of the blanket into the small trench, backfill the trench with soil and staple approximately every 18 inches. Staples are metal. "U"-shaped, and a minimum of 6 inches long. Longer staples are used in sandy soils. Biodegradable stakes are also available and should be used where applicable.
- Roll the blanket slowly down the slope as the installer walks backwards. The blanket rests against the installer's legs. Staples are installed as the blanket is unrolled. It is critical that the proper staple pattern is used for the blanket being installed. The blanket should not be allowed to roll down the slope on its own as this stretches the blanket, making it impossible to maintain soil contact. In addition, no one should be allowed to walk on the blanket after it is in place.
- If the blanket is not long enough to cover the entire slope length, the trailing edge of the upper blanket should overlap the leading edge of the lower blanket and be stapled. On steeper slopes, this overlap should be installed in a small trench, covered with soil and stapled.
- With the variety of products available, it is impossible to cover all the details of appropriate use and installation. Therefore, it is critical that the design engineer consults the manufacturer's information and that a site visit takes place in order to ensure that the product specified is appropriate. Information is also available at the WSDOT website:  
<http://www.wsdot.wa.gov/environment/>
- Jute matting must be used in conjunction with mulch (BMP C121). Excelsior, woven straw blankets, and coir (coconut fiber) blankets may be installed without mulch. There are many other types of erosion control nets and blankets on the market that may be appropriate in certain circumstances.
- In general, most nets (e.g., jute matting) require mulch in order to prevent erosion because they have a fairly open structure. Blankets typically do not require mulch because they usually provide complete protection of the surface.
- Extremely steep, unstable, wet, or rocky slopes are often appropriate candidates for use of synthetic blankets, as are riverbanks, beaches, and other high-energy environments. If synthetic blankets are used, the soil should be hydromulched first.
- 100 percent biodegradable blankets are available for use in sensitive areas. These organic blankets are usually held together with a paper or fiber mesh and stitching which may last up to a year.
- Most netting used with blankets is photodegradable, meaning it will break down under sunlight (not UV stabilized). However, this process can take months or years even under bright sun. Once vegetation is established, sunlight does not reach the mesh. It is not



uncommon to find non-degraded netting still in place several years after installation. This can be a problem if maintenance requires the use of mowers or ditch cleaning equipment. In addition, birds and small animals can become trapped in the netting.

#### **3.1.9.4 Maintenance Standards**

- Good contact with the ground must be maintained, and erosion must not occur beneath the net or blanket.
- Repair or staple any areas of the net or blanket that are damaged or not in close contact with the ground.
- If erosion occurs due to poorly controlled drainage, fix the problem and protect the eroded area.



**Figure 2 - 4. Nets and Blankets – Slope Installation**

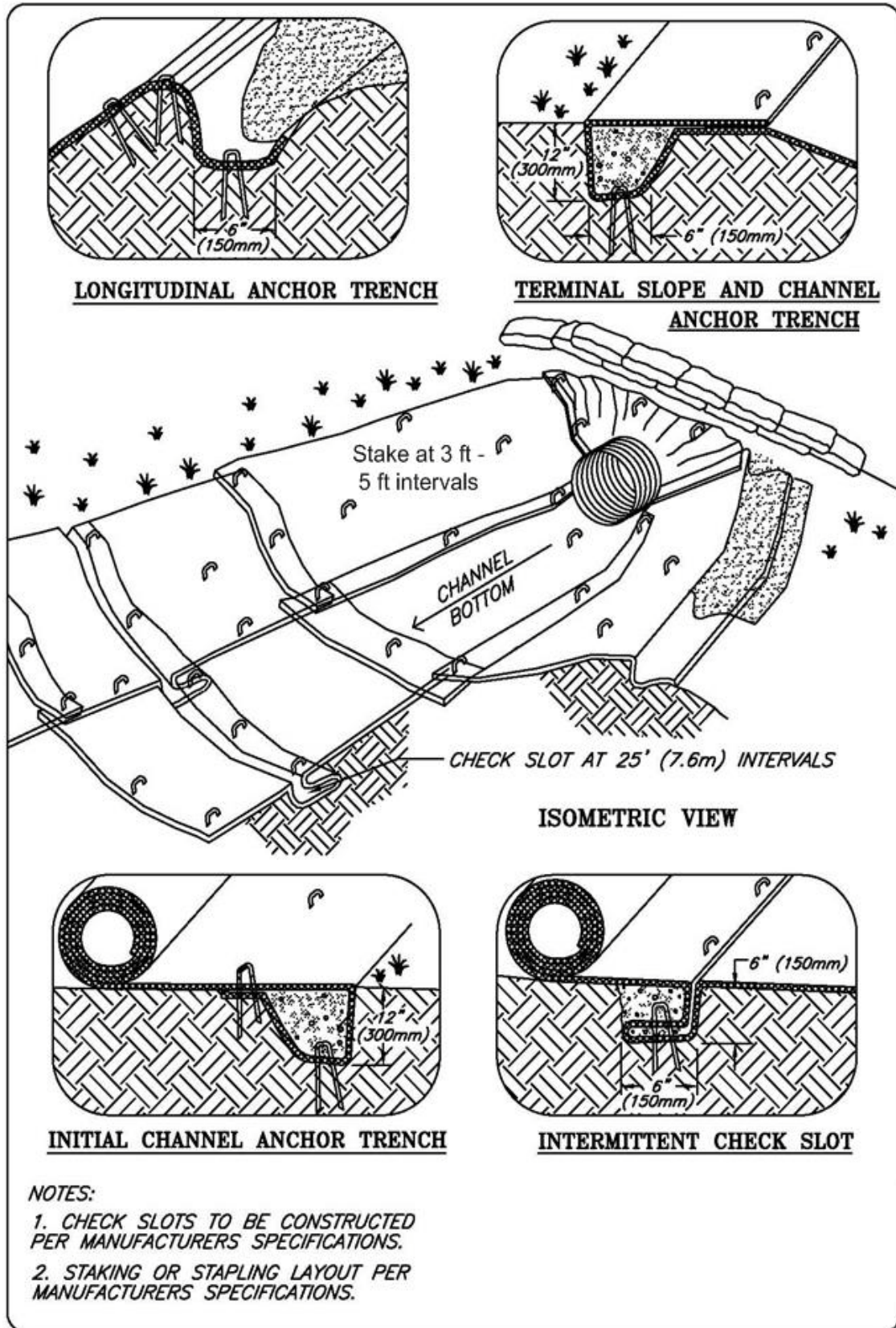


Figure 2 - 5. Nets and Blankets – Channel Installation

### **3.1.10 BMP C123: Plastic Covering**

#### **3.1.10.1 Purpose**

Plastic covering provides immediate, short-term erosion protection to slopes and disturbed areas.

#### **3.1.10.2 Conditions of Use**

- Plastic covering may be used on disturbed areas that require cover measures for less than 30 days, except as stated below.
- Plastic is particularly useful for protecting cut and fill slopes and stockpiles.
- The relatively rapid breakdown of most polyethylene sheeting makes it unsuitable for long-term (greater than six months) applications.
- Clear plastic sheeting can be used over newly-seeded areas to create a greenhouse effect and encourage grass growth if the hydroseed was installed too late in the season to establish 75 percent grass cover, or if the wet season started earlier than normal. Clear plastic should not be used for this purpose during the summer months because the resulting high temperatures can kill the grass.
- Due to rapid runoff caused by plastic covering, this method shall not be used upslope of areas that might be adversely impacted by concentrated runoff. Such areas include steep and/or unstable slopes.
- Whenever plastic is used to protect slopes, water collection measures must be installed at the base of the slope. These measures include plastic-covered berms, channels, and pipes used to convey clean rainwater away from bare soil and disturbed areas. At no time is clean runoff from a plastic covered slope to be mixed with dirty runoff from a project.
- Other uses for plastic include:
  - Temporary ditch liner;
  - Pond liner in temporary sediment pond;
  - Liner for bermed temporary fuel storage area if plastic is not reactive to the type of fuel being stored;
  - Emergency slope protection during heavy rains; and
  - Temporary drainpipe (“elephant trunk”) used to direct water.

#### **3.1.10.3 Design and Installation Specifications**

See Figure 3.1.11.

Plastic slope cover must be installed as follows:

- Run plastic up and down slope, not across slope.
- Plastic may be installed perpendicular to a slope if the slope length is less than 10 feet.
- Minimum of 8-inch overlap at seams.
- On long or wide slopes, or slopes subject to wind, all seams should be taped.
- Place plastic into a small (12-inch wide by 6-inch deep) slot trench at the top of the slope and backfill with soil to keep water from flowing underneath.

- Place sand filled burlap or geotextile bags every 3 to 6 feet along seams and pound a wooden stake through each to hold them in place. Alternative options for holding plastic in place exist and may be considered with COT approval.
- Inspect plastic for rips, tears, and open seams regularly and repair immediately. This prevents high velocity runoff from contacting bare soil, which causes extreme erosion;
- Plastic sheeting shall have a minimum thickness of 6 mil.
- If erosion at the toe of a slope is likely, a gravel berm, riprap, or other suitable protection shall be installed at the toe of the slope in order to reduce the velocity of runoff.

#### **3.1.10.4 Maintenance Standards**

- Torn sheets must be replaced and open seams repaired.
- If the plastic begins to deteriorate due to ultraviolet radiation, it must be completely removed and replaced.
- When the plastic is no longer needed, it shall be completely removed.
- Properly dispose of products used to weigh down covering.

### **3.1.11 BMP C124: Sodding**

#### **3.1.11.1 Purpose**

The purpose of sodding is to establish permanent turf for immediate erosion protection and to stabilize drainage ways where concentrated overland flow will occur.

#### **3.1.11.2 Conditions of Use**

Sodding may be used in the following areas:

- Disturbed areas that require short-term or long-term cover.
- Disturbed areas that require immediate vegetative cover.
- All waterways that require vegetative lining. Waterways may also be seeded rather than sodded, and protected with a net or blanket.

#### **3.1.11.3 Design and Installation Specifications**

Sod shall be free of weeds, of uniform thickness (approximately 1-inch thick), and shall have a dense root mat for mechanical strength.

The following steps are recommended for sod installation:

- Shape and smooth the surface to final grade in accordance with the approved grading plan. Overexcavate the swale 4 to 6 inches below design elevation to allow room for placing soil amendment and sod.
- Amend 4 inches (minimum) of compost into the top 8 inches of the soil if the organic content of the soil is less than ten percent or the infiltration rate is less than 0.6 inches per hour. Compost used shall:
  - Meet the definition for “composted material” per WAC 173-350-100 and comply with standards in WAC 173-350-220, except the feedstock may contain biosolids or manure feedstocks.
  - Have no visible water or dust during handling.
  - Have soil organic matter content of 40% to 65%.
  - Have a carbon to nitrogen ratio below 25:1. Carbon to nitrogen ratio may be as high as 35:1 for plantings composed entirely of plants native to the Puget Sound Lowlands region.  
  
City of Tacoma Tagro Potting Soil can be used as an alternative to the compost component in BMP C124
- Fertilize according to the supplier's recommendations.
- Work lime and fertilizer 1 to 2 inches into the soil, and smooth the surface.
- Lay strips of sod beginning at the lowest area to be sodded and perpendicular to the direction of water flow. Wedge strips securely into place. Square the ends of each strip to provide for a close, tight fit. Stagger joints at least 12 inches. Staple on slopes steeper than 3H:1V. Staple the upstream edge of each sod strip.
- Roll the sodded area and irrigate.
- When sodding is carried out in alternating strips or other patterns, seed the areas between the sod immediately after sodding.

### 3.1.11.4 Maintenance Standards

If the grass is unhealthy, the cause shall be determined and appropriate action taken to reestablish a healthy groundcover. If it is impossible to establish a healthy groundcover due to frequent saturation, instability, or some other cause, the sod shall be removed, the area seeded with an appropriate mix, and protected with a net or blanket.

### 3.1.12 BMP C125: Compost

#### 3.1.12.1 Purpose

The purpose of compost is to help establish vegetation and filter stormwater thus removing fine sediment and other contaminants. Compost can be used alone as a compost blanket, as a berm, or inside a sock.

#### 3.1.12.2 Conditions of Use

- Do not use if stormwater will discharge to a nutrient sensitive waterbody.
- Do not use as a storm drain inlet protection measure.

#### 3.1.12.3 Design and Installation Specifications

- Compost shall:
  - Meet the definition for “composted material” per WAC 173-350-100 and comply with standards in WAC 173-350-220, except the feedstock may contain biosolids or manure feedstocks.
  - Be coarse compost meeting the following size gradations (by dry weight) when tested in accordance with the U.S. Composting Council “Test Methods for the Examination of Compost and Composting” (TMECC) Test Method 02.02-B.

Sieve Size	Minimum Percent Passing
3"	100
1"	90
3/4"	70
1/4"	40

- Have no visible water or dust during handling.
- Have soil organic matter content of 40% to 65%.
- Have a carbon to nitrogen ratio below 25:1. Carbon to nitrogen ratio may be as high as 35:1 for plantings composed entirely of plants native to the Puget Sound Lowlands region.
- Do not use near wetlands or phosphorus impaired waterbodies.
- Compost can be later tilled into soils to help meet the requirements of BMP L613 – Post-Construction Soil Quality and Depth as required per Minimum Requirement #5.

City of Tacoma TAGRO Potting Soil can be used as an alternative to the compost component in BMP C125.

Compost specifications are also contained in Volume 5, Appendix E.

#### Compost Blankets

Compost blankets are simply compost blanketed over an area.

- Place compost 3" thick.
- Compost can be blown onto slopes up to 2:1 or spread by hand on shallower slopes.
- Compost can be mixed with a seed mix to ensure rapid vegetation.
- Compost does not need to be removed after construction phase unless required by the project engineer or geotechnical professional.

### **Compost Berms**

Compost berms are a perimeter sediment control that can be used instead of silt fence.

- Do not use compost berms on steep slopes.
- Berm width shall be a minimum of 2 feet.
- Berm height shall be a minimum of 12 inches.
- Berm width shall be twice the berm height.

Compost can be blown in place or placed by front-end loader.

Compost should be spread over proposed landscaped section when construction is complete to aid in revegetation.

### **Compost Socks**

Compost socks are similar to straw wattles.

- Sock material that is biodegradable will last up to 6 months and can be used for soil amendment after 6 months.
- Sock material that is non-biodegradable must be removed after construction is complete.
- Place socks perpendicular to flow.
- Walk socks in place to ensure good soil contact.
- Install wooden stakes every 12" on steep slopes or every 24" on shallow slopes

### **3.1.12.4 Maintenance Standards**

#### **Compost Blankets**

- Inspect compost regularly.
- Ensure a 3" thick blanket.

#### **Compost Berms**

- Inspect compost berm regularly.
- Ensure vehicular traffic does not cross berm and track compost offsite. If this occurs, sweep compost immediately.

#### **Compost Socks**

- Do not allow erosion or concentrated runoff under or around the barrier.
- Inspect the socks after each rainfall and repair any socks that tear or are not abutting the ground.



### **3.1.13 BMP C126: Topsoiling**

#### **3.1.13.1 Purpose**

To provide a suitable growth medium for final site stabilization with vegetation. While not a permanent cover practice in itself, topsoiling is an integral component of providing permanent cover in those areas where there is an unsuitable soil surface for plant growth. Native soils and disturbed soils that have been organically amended not only retain much more stormwater, but they also serve as effective biofilters for urban pollutants and, by supporting more vigorous plant growth, reduce the amount of water, fertilizer, and pesticides needed to support installed landscapes. Topsoil does not include any subsoils, only the material from the top several inches, including organic debris.

Use this BMP in conjunction with other BMPs such as seeding, mulching, or sodding. This BMP is functionally equivalent to BMP L613 Post-Construction Soil Quality and Depth which is required per Minimum Requirement #5 for disturbed areas that will be developed as lawn or landscaped areas at the completed project.

#### **3.1.13.2 Conditions of Use**

- Permanent landscaped areas shall contain healthy topsoil that reduces the need for fertilizers, improves overall topsoil quality, provides for better vegetal health and vitality, improves hydrologic characteristics, and reduces the need for irrigation.
- Leave native soils and the duff layer undisturbed to the maximum extent practicable.
- To the maximum extent practical, native soils disturbed during clearing and grading shall be restored to a condition equal to or better than the original site condition's moisture-holding capacity. Use onsite native topsoil, incorporate amendments into onsite soil, or import blended topsoil to meet this requirement.
- Topsoiling is a required procedure when establishing vegetation on shallow soils, and soils of critically low pH (high acid) levels.
- Stripping of the existing, properly functioning soil system and vegetation for the purpose of topsoiling during construction is not acceptable. If an existing soil system is functioning properly, it shall be preserved in its undisturbed and uncompacted condition.
- Depending on where the topsoil comes from, or what vegetation was on site before disturbance, invasive plant seeds may be included and could cause problems for establishing native plants, landscaped areas, or grasses.
- Topsoil from the site will contain mycorrhizal bacteria that are necessary for healthy root growth and nutrient transfer. These native mycorrhiza are acclimated to the site and will provide optimum conditions for establishing grasses. Commercially available mycorrhiza products should be used when topsoil is brought in from offsite.

#### **3.1.13.3 Design and Installation Specifications**

If topsoiling is to be done, the following items should be considered:

- Topsoil shall have:
  - A minimum depth of 8-inches. Scarify subsoils below the topsoil layer at least 4-inches with some incorporation of the upper material to avoid stratified layers, where feasible. Ripping or restructuring the subgrade may also provide additional benefits regarding the overall infiltration and interflow dynamics of the soil system.

- A minimum organic content of 10% dry weight in planting beds, and 5% organic matter content in turf areas. Incorporate organic amendments to a minimum 8-inch except where tree roots or other natural features limit the depth of incorporation.
- A pH between 6.0 and 8.0 or matching the pH of the undisturbed soil.
- To obtain a topsoil meeting the above specifications return native topsoil to the site, import topsoil of sufficient organic content, and/or incorporate organic amendments:
  - To meet the organic content requirements, the compost shall:
    - Meet the definition for “composted material” per WAC 173-350-100 and comply with standards in WAC 173-350-220, except the feedstock may contain biosolids or manure feedstocks.
    - Have no visible water or dust during handling.
    - Have soil organic matter content of 40% to 65%.
    - Have a carbon to nitrogen ratio below 25:1. Carbon to nitrogen ratio may be as high as 35:1 for plantings composed entirely of plants native to the Puget Sound Lowlands region.
  - City of Tacoma TAGRO Topsoil Mix can be used as an alternative to the compost component in BMP C125.
  - For till soils use a mixture of approximately two parts soil to one part compost. This equates to 4 inches of compost mixed to a depth of 12 inches in till soils. Increasing the concentration of compost beyond this level can have negative effects on vegetal health, while decreasing the concentrations can reduce the benefits of amended soils.
- Mulch planting beds with 2” of organic material.
- If blended topsoil is imported, fines should be limited to 25 percent passing through a 200 sieve.
- The final composition and construction of the soil system will result in a natural selection or favoring of certain plant species over time. For example, recent practices have shown that incorporation of topsoil may favor grasses, while layering with mildly acidic, high-carbon amendments may favor more woody vegetation.
- Locate the topsoil stockpile so it meets specifications and does not interfere with work on the site. It may be possible to locate more than one pile in proximity to areas where topsoil will be used.
- Allow sufficient time in scheduling for topsoil to be spread prior to seeding, sodding, or planting.
- Do not place topsoil while in a frozen or muddy condition, when the subgrade is excessively wet, or when conditions exist that may otherwise be detrimental to proper grading or proposed sodding or seeding.
- Care must be taken not to apply topsoil over subsoil if the two soils have contrasting textures. Sandy topsoil over clayey subsoil is a particularly poor combination, as water creeps along the junction between the soil layers and causes the topsoil to slough.
- If topsoil and subsoil are not properly bonded, water will not infiltrate the soil profile evenly and it will be difficult to establish vegetation. The best method to prevent a lack of bonding is to work the topsoil into the layer below for a depth of at least 6 inches.

- Field exploration of the site shall be made to determine if there is surface soil of sufficient quantity and quality to justify stripping. Topsoil shall be friable and loamy (loam, sandy loam, silt loam, sandy clay loam, clay loam). Areas of natural groundwater recharge should be avoided.
- Confine stripping to the immediate construction area. A 4- to 6- inch stripping depth is common, but depth may vary depending on the particular soil. Place all surface runoff control structures in place prior to stripping.

Stockpile topsoil in the following manner:

- Side slopes of the stockpile shall not exceed 2:1.
- Surround all topsoil stockpiles between October 1 and April 30 with an interceptor dike with gravel outlet and silt fence. Between May 1 and September 30, install an interceptor dike with gravel outlet and silt fence if the stockpile will remain in place for a longer period of time than active construction grading.
- Complete erosion control seeding or covering with clear plastic or other mulching materials of stockpiles within 2 days (October 1 through April 30) or 7 days (May 1 through September 30) of the formation of the stockpile. Do not cover native topsoil stockpiles with plastic.
- Topsoil shall not be placed while in a frozen or muddy condition, when the subgrade is excessively wet, or when conditions exist that may otherwise be detrimental to proper grading or proposed sodding or seeding.
- Maintain previously established grades on the areas to be topsoiled according to the approved plan.
- When native topsoil is to be stockpiled and reused, the following should apply to ensure that the mycorrhizal bacterial, earthworms, and other beneficial organisms will not be destroyed:
  - Topsoil is to be re-installed within 4 to 6 weeks;
  - Topsoil is not to become saturated with water;
  - Plastic cover is not allowed.

#### **3.1.13.4 Maintenance Standards**

- Inspect stockpiles regularly, especially after large storm events. Stabilize any areas that have eroded.
- Establish soil quality and depth toward the end of the construction. Once established, protect from compaction and erosion.
- Plant and mulch soil after installation.
- Leave plant debris or its equivalent on the soil surface to replenish organic matter.
- Reduce and adjust, where possible, the use of irrigation, fertilizers, herbicides and pesticides, rather than continuing to implement formerly established practices.

### **3.1.14 BMP C127: Polyacrylamide for Soil Erosion Protection**

#### **3.1.14.1 Purpose**

Polyacrylamide (PAM) is used on construction sites to prevent soil erosion.

Applying PAM to bare soil in advance of a rain event significantly reduces erosion and controls sediment in two ways. PAM helps maintain soil structure, which increases the ability to infiltrate.

#### **3.1.14.2 Conditions of Use**

**Do not apply PAM directly to water or allow it to enter a water body.** In areas that drain to a sediment pond, PAM can be applied to bare soil under the following conditions:

- During rough grading operations.
- Staging areas.
- Balanced cut and fill earthwork.
- Haul roads prior to placement of crushed rock surfacing.
- Compacted soil roadbase.
- Stockpiles.
- After final grade and before paving or final seeding and planting.
- Pit sites.
- Sites having a winter shut down. In the case of winter shut down, or where soil will remain unworked for several months, PAM should be used together with mulch.

#### **3.1.14.3 Design and Installation Specifications**

PAM may be applied in dissolved form with water, or it may be applied in dry, granular or powdered form. The preferred application method is the dissolved form.

PAM is to be applied at a maximum rate of 2/3 pound PAM per 1,000 gallons water (80 mg/L) per 1 acre of bare soil. Higher concentrations of PAM **do not** provide any additional effectiveness.

##### ***The Preferred Method:***

- Pre-measure the area where PAM is to be applied and calculate the amount of product and water necessary to provide coverage at the specified application rate (2/3 pound PAM per 1,000 gallons per acre).
- PAM is water soluble, but dissolves very slowly. Dissolve pre-measured dry granular PAM with a known quantity of clean water in a bucket several hours or overnight. Mechanical mixing will help dissolve the PAM. Always add PAM to water - not water to PAM.
- Pre-fill the water truck about 1/8 full with water. The water does not have to be potable, but it must have relatively low turbidity – in the range of 20 NTU or less.
- Add PAM and water mixture to the truck.
- Completely fill the water truck to specified volume.
- Spray PAM and water mixture onto dry soil until the soil surface is uniformly and completely wetted.

***An Alternate Method:***

PAM may also be applied as a powder at the rate of 5 pounds per acre. This must be applied on a day that is dry. For areas less than 5 to 10 acres, a hand-held “organ grinder” fertilizer spreader set to the smallest setting will work. Tractor-mounted spreaders will work for larger areas.

***Benefits and Limitations:***

The following benefits and limitations should be considered:

- PAM shall be used in conjunction with other BMPs and not in place of other BMPs.
- Do not use PAM on a slope that flows directly into a stream or wetland or any other waterbody.
- PAM has little to no effect on sandy soils with little clay content.
- Do not add PAM to water discharging from site.
- When the total drainage area is greater than or equal to 5 acres, PAM treated areas shall drain to a sediment pond.
- Areas less than 5 acres shall drain to sediment control BMPs, such as a minimum of 3 check dams per acre. The total number of check dams used shall be maximized to achieve the greatest amount of settlement of sediment prior to discharging from the site. Each check dam shall be spaced evenly in the drainage channel through which stormwater flows are discharged offsite.
- On all sites, use silt fences to limit the discharges of sediment from the site.
- Cover and protect all areas not being actively worked from rainfall. PAM shall not be the only cover BMP used.
- PAM can be applied to wet soil, but dry soil is preferred due to less sediment loss.
- PAM will work when applied to saturated soil but is not as effective as applications to dry or damp soil.
- Keep the granular PAM supply out of the sun. Granular PAM loses its effectiveness in three months after exposure to sunlight and air.
- Proper application and re-application plans are necessary to ensure total effectiveness of PAM usage.
- PAM, combined with water, is very slippery and can be a safety hazard. Care must be taken to prevent spills of PAM powder onto paved surfaces. During an application of PAM, prevent over-spray from reaching pavement, as pavement will become slippery. If PAM powder gets on skin or clothing, wipe it off with a rough towel rather than washing with water, which makes cleanup messier and take longer.
- Some PAMs are more toxic and carcinogenic than others. Only the most environmentally safe PAM products should be used.

- The specific PAM copolymer formulation must be anionic. **Cationic PAM shall not be used in any application because of known aquatic toxicity problems.** Only the highest drinking water grade PAM, certified for compliance with ANSI/NSF Standard 60 for drinking water treatment, will be used for soil applications. PAM use shall be reviewed and approved by the City. The Washington State Department of Transportation (WSDOT) has listed approved PAM products on its web page.

<http://www.wsdot.wa.gov/Environment/WaterQuality/ErosionControl.htm>

- PAM designated for these uses should be "water soluble", "linear", or "non-crosslinked". Cross-linked or water absorbent PAM, polymerized in highly acidic (pH<2) conditions, are used to maintain soil moisture content.
- The PAM anionic charge density may vary from 2 to 30 percent; a value of 18 percent is typical. Studies conducted by the United States Department of Agriculture (USDA)/ARS demonstrated that soil stabilization was optimized by using very high molecular weight (12-15 mg/mole), highly anionic (>20% hydrolysis) PAM.
- PAM tackifiers are available and being used in place of guar and alpha plantago. Typically, PAM tackifiers should be used at a rate of no more than 0.5 to 1 pounds per 1,000 gallons of water in a hydromulch machine. Some tackifier product instructions say to use at a rate of 3 to 5 pounds per acre, which can be too much. In addition, pump problems can occur at higher rates due to increased viscosity.

#### **3.1.14.4 Maintenance Standards**

- PAM may be reapplied on actively worked areas after a 48-hour period.
- Reapplication is not required unless PAM treated soil is disturbed or turbidity levels show the need for an additional application. If PAM treated soil is left undisturbed, a reapplication may be necessary after two months. When PAM is applied first to bare soil and then covered with straw, a reapplication may not be necessary for several months.
- Loss of sediment and PAM may be a basis for penalties per RCW 90.48.080.

#### **3.1.15 BMP C130: Surface Roughening**

##### **3.1.15.1 Purpose**

Surface roughening aids in the establishment of vegetative cover, reduces runoff velocity, increases infiltration, and provides for sediment trapping through the provision of a rough soil surface. Horizontal depressions are created by operating a tiller or other suitable equipment on the contour or by leaving slopes in a roughened condition by not fine grading them.

##### **3.1.15.2 Conditions for Use**

- All slopes steeper than 3H:1V and greater than 5 vertical feet require surface roughening.
- Areas with grades steeper than 3H:1V should be roughened to a depth of 2 to 4 inches prior to seeding.
- Areas that will not be stabilized immediately may be roughened to reduce runoff velocity until seeding takes place.
- Slopes with a stable rock face do not require roughening.
- Slopes where mowing is planned should not be excessively roughened.

### **3.1.15.3 Design and Installation Specifications**

- There are different methods for achieving a roughened soil surface on a slope, and the selection of an appropriate method depends upon the type of slope. Roughening methods include stair-step grading, grooving, contour furrows, and tracking. See Figure 2 - 6 for tracking and contour furrows. Factors to be considered in choosing a method are slope steepness, mowing requirements, and whether the slope is formed by cutting or filling.
- Disturbed areas that will not require mowing may be stair-step graded, grooved, or left rough after filling.
- Stair-step grading is particularly appropriate in soils containing large amounts of soft rock. Each "step" catches material that sloughs from above, and provides a level site where vegetation can become established. Stairs should be wide enough to work with standard earth moving equipment. Stair steps must be on contour or gullies will form on the slope.
- Areas that will be mowed (these areas should have slopes less steep than 3:1) may have small furrows left by disking, harrowing, raking, or seed-planting machinery operated on the contour.
- Graded areas with slopes greater than 3:1 but less than 2:1 should be roughened before seeding. This can be accomplished in a variety of ways, including "track walking," or driving a crawler tractor up and down the slope, leaving a pattern of cleat imprints parallel to slope contours.
- Tracking is done by operating equipment up and down the slope to leave horizontal depressions in the soil.

### **3.1.15.4 Maintenance Standards**

- Areas that are graded in this manner should be seeded as quickly as possible.
- Regular inspections should be made of the area. If rills appear, they should be re-graded and re-seeded immediately.

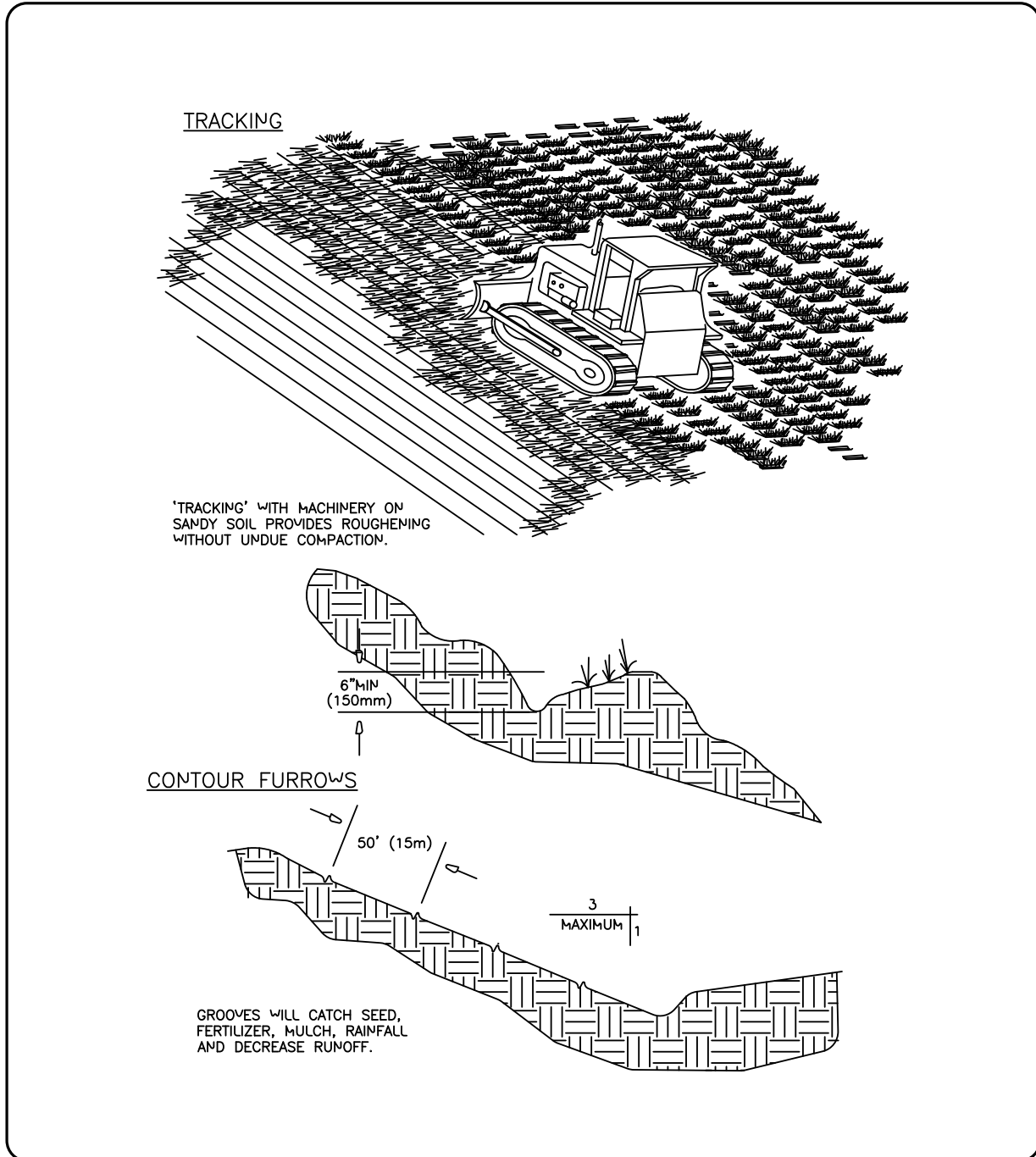


Figure 2 - 6. Surface Roughening by Tracking and Contour Furrows

### 3.1.16 BMP C131: Gradient Terraces

#### 3.1.16.1 Purpose

Gradient terraces reduce erosion damage by intercepting surface runoff and conducting it to a stable outlet at a non-erosive velocity.



### 3.1.16.2 Conditions of Use

Gradient terraces normally are limited to denuded land having a water erosion problem. They should not be constructed on deep sands or on soils that are too stony, steep, or shallow to permit practical and economical installation and maintenance. Gradient terraces may be used only where suitable outlets are or will be made available. See Figure 2 - 7 for gradient terraces.

### 3.1.16.3 Design and Installation Specifications

The maximum vertical spacing of gradient terraces should be determined by the following method:

$$VI = (0.8)s + y$$

Where:

VI = vertical interval in feet

s = land rise per 100 feet, expressed in feet

y = a soil and cover variable with values from 1.0 to 4.0

Values of “y” are influenced by soil erodibility and cover practices. The lower values are applicable to erosive soils where little to no residue is left on the surface. The higher value is applicable only to erosion-resistant soils where a large amount of residue (1½ tons of straw/acre equivalent) is on the surface.

- The minimum constructed cross-section should meet the design dimensions.
- The top of the constructed ridge should not be lower at any point than the design elevation plus the specified overfill for settlement. The opening at the outlet end of the terrace should have a cross section equal to that specified for the terrace channel.
- Channel grades may be either uniform or variable with a maximum grade of 0.6 feet per 100 feet length. For short distances, terrace grades may be increased to improve alignment. The channel velocity should not exceed that which is non-erosive for the soil type with the planned treatment.
- All gradient terraces should have adequate outlets. Such an outlet may be a grassed waterway, vegetated area, or tile outlet. In all cases, the outlet must convey runoff from the terrace or terrace system to a point where the outflow will not cause damage. Vegetative cover should be used in the outlet channel.
- The design elevation of the water surface of the terrace should not be lower than the design elevation of the water surface in the outlet at their junction, when both are operating at design flow.
- Vertical spacing determined by the above methods may be increased as much as 0.5 feet or 10 percent, whichever is greater, to provide better alignment or location, avoid obstacles, adjust for equipment size, or reach a satisfactory outlet.
- The drainage area above the top should not exceed the area that would be drained by a terrace with normal spacing.
- The terrace should have enough capacity to handle the peak runoff expected from a 2-year, 24-hour design storm without overtopping.
- The terrace cross-section should be proportioned to fit the land slope. The ridge height should include a reasonable settlement factor. The ridge should have a minimum top width of 3 feet at the design height. The minimum cross-sectional area of the terrace channel should be 8 square feet for land slopes of 5 percent or less, 7 square feet for

slopes from 5 to 8 percent, and 6 square feet for slopes steeper than 8 percent. The terrace can be constructed wide enough to be maintained using a small cat.

### 3.1.16.4 Maintenance Standards

Maintenance should be performed as needed. Terraces should be inspected regularly, at least once a year, and after large storm events.

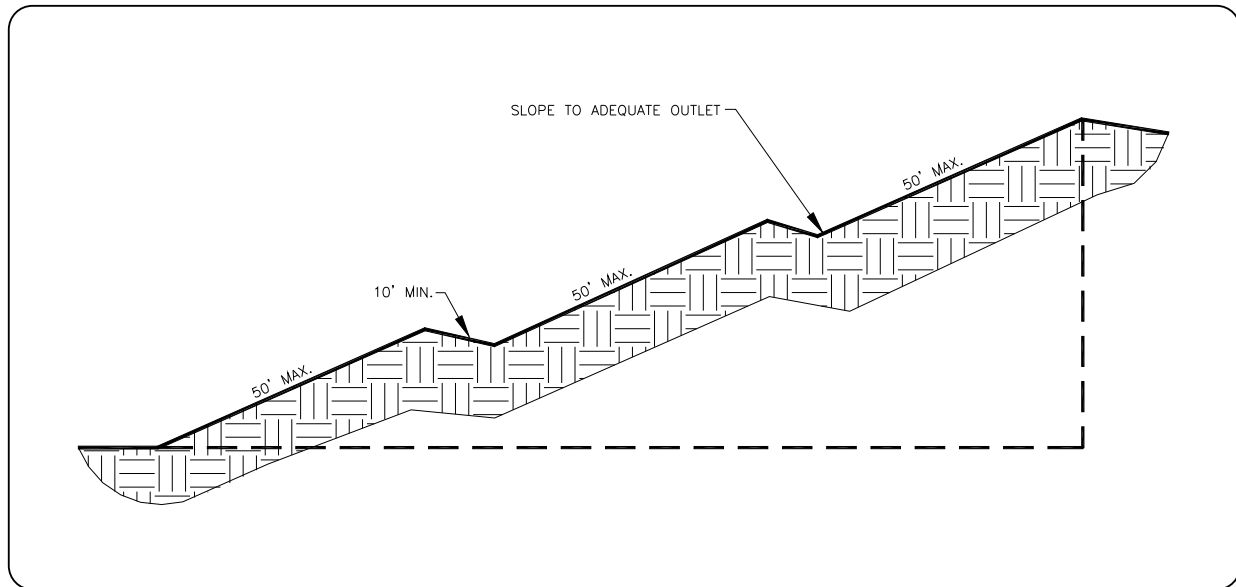


Figure 2 - 7. Gradient Terraces

### 3.1.17 BMP C140: Dust Control

#### 3.1.17.1 Purpose

Dust control prevents wind transport of dust from disturbed soil surfaces onto roadways, drainage ways, and surface waters.

#### 3.1.17.2 Conditions of Use

Use dust control practices in areas (including roadways) subject to surface and air movement of dust where onsite and offsite impacts to roadways, drainage ways, or surface waters are likely.

#### 3.1.17.3 Design and Installation Specifications

- Vegetate or mulch areas that will not receive vehicle traffic. In areas where planting, mulching, or paving is impractical, apply gravel or landscaping rock.
- Limit dust generation by clearing only to those areas where immediate activity will take place, leaving the remaining area(s) in the original condition, if stable. Maintain the original ground cover as long as practical.
- Construct natural or artificial windbreaks or windscreens. These may be designed as enclosures for small dust sources.
- Sprinkle the site with water until surface is wet. Repeat as needed. To prevent carryout of mud onto street, refer to Stabilized Construction Entrance (BMP C105).

- Irrigation water can be used for dust control. Install irrigation systems as a first step on sites where dust control is a concern.
- Spray exposed soil areas with a dust palliative, following the manufacturer's instructions and cautions regarding handling and application. Used oil is prohibited from use as a dust suppressant. The City may approve other dust palliatives such as calcium chloride or PAM.
- PAM (BMP C127) added to water at a rate of 2/3 pounds per 1,000 gallons of water per acre and applied from a water truck is more effective than water alone. This is due to the increased infiltration of water into the soil and reduced evaporation. In addition, small soil particles are bonded together and are not as easily transported by wind. Adding PAM may actually reduce the quantity of water needed for dust control. There are concerns with the proper use of PAM, refer to BMP C127 for more information on PAM application. PAM use requires COT approval.
- Lower speed limits. High vehicle speed increases the amount of dust stirred up from unpaved roads and lots.
- Upgrade the road surface strength by improving particle size, shape, and mineral types that make up the surface and base materials.
- Add surface gravel to reduce the source of dust emission. Limit the amount of fine particles to 10 to 20 percent.
- Use geotextile fabrics to increase the strength of new roads or roads undergoing reconstruction.
- Encourage the use of alternate, paved routes, if available.
- Restrict use of paved roadways by tracked vehicles and heavy trucks to prevent damage to road surfaces and bases.
- Apply chemical dust suppressants using the admix method, blending the product with the top few inches of surface material. Suppressants may also be applied as surface treatments.
- Pave unpaved permanent roads and other trafficked areas.
- Use vacuum street sweepers.
- Remove mud and other dirt promptly so it does not dry and then turn into dust.
- Limit dust-causing work on windy days.
- Contact the Puget Sound Clean Air Agency for guidance and training on other dust control measures. Compliance with the Puget Sound Clean Air Agency's recommendations/requirements constitutes compliance with this BMP.

#### **3.1.17.4 Maintenance Standards**

Evaluate the potential for dust generation frequently during dry periods. Complete the actions outlined above as needed to limit the dust.

Any dust which leaves the site must be cleaned immediately.

#### **3.1.18 BMP C150: Materials On Hand**

##### **3.1.18.1 Purpose**

Quantities of erosion prevention and sediment control materials should be kept on the project site at all times to be used for regular maintenance and emergency situations such as unexpected

heavy summer rains. Having these materials onsite reduces the time needed to implement BMPs when inspections indicate that existing BMPs are not meeting the Construction SWPPP requirements.

### 3.1.18.2 Conditions of Use

Construction projects of any size or type can benefit from having materials on hand. A small commercial development project could have a roll of plastic and some gravel available for immediate protection of bare soil and temporary berm construction. A large earthwork project, such as highway construction, might have several tons of straw, several rolls of plastic, flexible pipe, sandbags, geotextile fabric, and steel “T” posts.

- Materials are stockpiled and readily available before any site clearing, grubbing, or earthwork begins. A large contractor or developer could keep a stockpile of materials that are available to be used on several projects.
- If storage space at the project site is at a premium, the contractor could maintain the materials at a location less than one hour from the project site.

### 3.1.18.3 Design and Installation Specifications

Depending on project type, size, complexity, and length, materials and quantities will vary. Table 2 - 9 provides a good minimum that will cover numerous situations.

**Table 2 - 9: Materials on Hand**

Material	Measure	Quantity
Clear Plastic, 6 mil	100 foot roll	1-2
Drainpipe, 6 or 8 inch diameter	25 foot section	4-6
Sandbags, filled	each	25-50
Quarry Spalls	ton	2-4
Washed Gravel	cubic yard	2-4
Geotextile Fabric	100 foot roll	1-2
Catch Basin Inserts	each	2-4
Steel “T” Posts	each	12-24

### 3.1.18.4 Maintenance Standards

- All materials with the exception of the quarry spalls, steel “T” posts, and gravel should be kept covered and out of both sun and rain.
- Re-stock materials used as needed.

## 3.1.19 BMP C151: Concrete Handling

### 3.1.19.1 Purpose

Concrete work can generate process water and slurry that contain fine particles and high pH, both of which can violate water quality standards in the receiving water. This BMP is intended to minimize and eliminate concrete, concrete process water and concrete slurry from entering waters of the state.

### **3.1.19.2 Conditions of Use**

Utilize these management practices any time concrete is used.

Concrete construction projects include, but are not limited to, the following:

- Curbs
- Sidewalks
- Roads
- Bridges
- Foundations
- Floors
- Runways

### **3.1.19.3 Design and Installation Specifications**

- Concrete trucks, chutes, pumps, and internals shall be washed out only at an approved offsite location or in designated washout areas.
- Unused concrete remaining in the truck and pump shall be returned to the originating batch plant for recycling.
- Hand tools shall be washed off only into formed areas awaiting installation of concrete or asphalt.
- Equipment that cannot be easily moved, such as concrete pavers, shall only be washed in areas that do not directly drain to natural or constructed stormwater conveyances.
- Washdown from areas such as concrete aggregate driveways shall not drain directly to natural or constructed stormwater conveyances.
- Do not wash out concrete trucks onto the ground, or into storm drains, open ditches, streets, or streams. Refer to BMP C151 for information concerning concrete handling and BMP C154 for information concerning concrete washout areas.
- Always use forms or solid barriers for concrete pours within 15-feet of surface waters.
- Refer to BMPs C252 and C253 for pH adjustment requirements.
- Refer to the Construction Stormwater General Permit for pH monitoring requirements if the project involves one of the following activities:
  - Significant concrete work (greater than 1,000 cubic yards poured concrete or recycled concrete used over the life of a project).
  - The use of engineered soils amended with (but not limited to) Portland cement-treated base, cement kiln dust or fly ash.
  - Discharging stormwater to segments of water bodies on the 303(d) list (Category 5) for high pH.

### **3.1.19.4 Maintenance Standards**

Containers shall be checked for holes in the liner daily during concrete pours and repaired the same day.

### **3.1.20 BMP C152: Sawcutting and Surfacing Pollution Prevention**

#### **3.1.20.1 Purpose**

Sawcutting and surfacing operations generate slurry and process water that contains fine particles and high pH (concrete cutting), both of which can violate water quality standards in the receiving water. This BMP is intended to minimize and eliminate process water and slurry from entering waters of the State

#### **3.1.20.2 Conditions of Use**

Anytime sawcutting or surfacing operations take place, use these management practices. Sawcutting and surfacing operations include, but are not limited to, the following:

- Sawing
- Coring
- Grinding
- Roughening
- Hydro-demolition
- Bridge and road surfacing

#### **3.1.20.3 Design and Installation Specifications**

- Vacuum slurry and cuttings during cutting and surfacing operations.
- Do not leave slurry and cuttings on permanent concrete or asphalt pavement overnight.
- Do not drain slurry and cuttings to any natural or constructed drainage conveyance.
- Dispose of collected slurry and cuttings in a manner that does not violate groundwater or surface water quality standards.
- Do not drain process water that is generated during hydro-demolition, surface roughening, or similar operations to any natural or constructed drainage conveyance. Dispose of process water in a manner that does not violate groundwater or surface water quality standards.
- Handle and dispose of cleaning waste material and demolition debris in a manner that does not cause contamination of water. If the area is swept with a pick-up sweeper, haul the material out of the area to an appropriate disposal site.

#### **3.1.20.4 Maintenance Standards**

Continually monitor operations to determine whether slurry, cuttings, or process water could enter waters of the state. If inspections show that a violation of water quality standards could occur, stop operations and immediately implement preventive measures such as berms, barriers, secondary containment, and vacuum trucks.

### **3.1.21 BMP C153: Material Delivery, Storage and Containment**

#### **3.1.21.1 Purpose**

Prevent, reduce, or eliminate the discharge of pollutants from material delivery and storage to the stormwater system or watercourses by minimizing the storage of hazardous materials onsite, storing materials in a designated area, and installing secondary containment.

### **3.1.21.2 Conditions of Use**

These procedures are suitable for use at all construction sites with delivery and storage of the following materials:

- Petroleum products such as fuel, oil, and grease
- Soil stabilizers and binders (e.g. Polyacrylamide)
- Fertilizers, pesticides, and herbicides
- Detergents
- Asphalt and concrete compounds
- Hazardous chemicals such as acids, lime, adhesives, paints, solvents, and curing compounds
- Any other material that may be detrimental if released to the environment

### **3.1.21.3 Design and Installation Specifications**

The following steps should be taken to minimize risk:

- Locate temporary storage area away from vehicular traffic, near the construction entrance(s), and away from waterways or storm drains.
- Supply Material Safety Data Sheets (MSDS) for all materials stored. Keep chemicals in their original labeled containers.
- Surrounding materials with earth berms is an option for temporary secondary containment.
- Minimize hazardous material storage onsite.
- Handle hazardous materials as infrequently as possible.
- During the wet weather season (October 1 through April 30), consider storing materials in a covered area.
- Store materials in secondary containment, such as an earthen dike, a horse trough, or a children's wading pool for non-reactive materials such as detergents, oil, grease, and paints. "Bus boy" trays or concrete mixing trays may be used as secondary containment for small amounts of material.
- Do not store chemicals, drums, or bagged materials directly on the ground. Place these items on a pallet and, when possible, in secondary containment.
- If drums cannot be stored under a roof, domed plastic covers are inexpensive and snap to the top of drums, preventing water from collecting.

### **3.1.21.4 Material Storage Areas and Secondary Containment Practices:**

- Store liquids, petroleum products, and substances listed in 40 CFR Parts 110, 117, or 302 in approved containers and drums and do not overfill the containers or drums. Store containers and drums in temporary secondary containment facilities.
- Temporary secondary containment facilities shall provide for a spill containment volume able to contain precipitation from a 25 year, 24 hour storm event plus 10% of the total enclosed container volume of all containers, or 110% of the capacity of the largest container within its boundary, whichever is greater.

- Secondary containment facilities shall be impervious to the materials stored therein for a minimum contact time of 72 hours.
- Secondary containment facilities shall be maintained free of accumulated rainwater and spills. In the event of spills or leaks, collect accumulated rainwater and spills and place into drums. Handle these liquids as hazardous waste unless testing determines them to be non-hazardous. Dispose of all wastes properly.
- Provide sufficient separation between stored containers to allow for spill cleanup and emergency response access.
- During the wet weather season (October 1 through April 30), cover each secondary containment facility during non-working days, prior to and during rain events.
- Keep material storage areas clean, organized, and equipped with an ample supply of appropriate spill clean-up material.
- The spill kit should include, at a minimum:
  - 1 water resistant nylon bag
  - 3 oil absorbent socks (3-inches by 4-feet)
  - 2 oil absorbent socks (3-inches by 10-feet)
  - 12 oil absorbent pads (17-inches by 19-inches)
  - 1 pair splash resistant goggles
  - 3 pairs nitrile gloves
  - 10 disposable bags with ties
  - Instructions

### **3.1.21.5 Maintenance**

Any stormwater within the material storage area shall be pumped or otherwise discharged after each rain event. Before pumping, the stormwater must be evaluated to determine if it must go to treatment or can be discharged without treatment. If stormwater is contaminated, direct the discharge to appropriate treatment.

## **3.1.22 BMP C154: Concrete Washout Area**

### **3.1.22.1 Purpose**

Prevent or reduce the discharge of pollutants to stormwater from concrete waste by conducting washout offsite, or performing onsite washout in a designated area to prevent pollutants from entering surface waters or groundwater.

### **3.1.22.2 Conditions of Use**

Use concrete washout best management practices on construction projects where:

- It is not possible to dispose of all concrete wastewater and washout offsite (ready mix plant, etc.)
- Concrete trucks, pumpers, or other concrete coated equipment are washed onsite.



**NOTE:** If less than 3 concrete trucks or pumpers need to be washed onsite, the washwater may be disposed of in a formed area awaiting concrete. Do not allow dirty water to enter storm drains, open ditches, or any waterbody.

### **3.1.22.3 Implementation**

- Perform washout of concrete trucks offsite or in designated concrete washout areas only.
- Do not wash out concrete trucks onto the ground, or into storm drains, open ditches, streets, or streams.
- Do not allow excess concrete to be dumped onsite, except in designated concrete washout areas.
- Concrete washout areas may be prefabricated concrete washout containers, or self-installed structures (above-grade or below-grade).
  - Prefabricated containers are most resistant to damage and protect against spills and leaks. Companies may offer delivery service and provide regular maintenance and disposal of solid and liquid waste.
  - If self-installed concrete washout areas are used, below-grade structures are preferred over above-grade structures because they are less prone to spills and leaks.
  - Self-installed above-grade structures should only be used if excavation is not practical.
- Identify concrete washout area on the TESC plan.

### **3.1.22.4 Education**

- Discuss the concrete management techniques described in this BMP with the ready-mix concrete supplier before any deliveries are made.
- Educate employees and subcontractors on the concrete waste management techniques described in this BMP.
- Install a sign adjacent to each temporary concrete washout facility to inform concrete equipment operators to utilize the proper facilities.

### **3.1.22.5 Location and Placement Considerations:**

- Locate washout area or temporary concrete washout facilities at least 50 feet from sensitive areas such as storm drains, open ditches, or water bodies, including wetlands.
- Allow convenient access for concrete trucks, preferably near the area where the concrete is being poured.
- If trucks need to leave a paved area to access washout, prevent track-out with a pad of rock or quarry spalls ([BMP C105](#)). These areas should be far enough away from other construction traffic to reduce the likelihood of accidental damage and spills.
- The washout area volume installed should depend on the expected demand for storage capacity.
- On large sites with extensive concrete work, washouts may be placed in multiple locations for ease of use by concrete truck drivers.

**3.1.22.6 Onsite Temporary Concrete Washout Facility, Transit Truck Washout Procedures:**

- Locate temporary washout facilities at least 50 feet from sensitive areas including storm drain inlets, open drainage facilities, and surface waterbodies.
- Construct and maintain concrete washout facilities in order to contain all liquid and concrete waste generated by washout operations.
  - Approximately 7 gallons of wash water are used to wash one truck chute.
  - Approximately 50 gallons are used to wash out the hopper of a concrete pump truck.
- Washout of concrete trucks shall be performed in designated areas only.
- Concrete washout from concrete pumper bins can be washed into concrete pumper trucks and discharged into designated washout area or properly disposed of offsite.
- Once concrete wastes are washed into the designated area and allowed to harden, the concrete should be broken up, removed, and disposed of per applicable solid waste regulations. Dispose of hardened concrete on a regular basis.

***Temporary Above-Grade Concrete Washout Facility***

- Temporary concrete washout facility (type above grade) should be constructed as shown on the details at the end of this BMP, with a recommended minimum length and minimum width of 10 ft, but with sufficient quantity and volume to contain all liquid and concrete waste generated by washout operations.
- Plastic lining material should be a minimum of 10 mil polyethylene sheeting and should be free of holes, tears, or other defects that compromise the impermeability of the material.

**Temporary Below-Grade Concrete Washout Facility**

- Temporary concrete washout facilities (type below grade) should be constructed as shown on the details at the end of this BMP, with a recommended minimum length and minimum width of 10 ft. The quantity and volume should be sufficient to contain all liquid and concrete waste generated by washout operations.
- Lath and flagging should be commercial type.
- Plastic lining material shall be a minimum of 10 mil polyethylene sheeting and should be free of holes, tears, or other defects that compromise the impermeability of the material.
- Liner seams shall be installed in accordance with manufacturers' recommendations.
- Soil base shall be prepared free of rocks or other debris that may cause tears or holes in the plastic lining material.

**3.1.22.7 Inspection and Maintenance**

- Inspect and verify that concrete washout BMPs are in place prior to the commencement of concrete work.
- During periods of concrete work, inspect daily to verify continued performance.
  - Check overall condition and performance.
  - Check remaining capacity (% full).
  - If using self-installed washout facilities, verify plastic liners are intact and sidewalls are not damaged.
  - If using prefabricated containers, check for leaks.
- Maintain washout facilities to provide adequate holding capacity with a minimum freeboard of 12 inches.
- Washout facilities must be cleaned, or new facilities must be constructed and ready for use once the washout is 75% full.
- If the washout is nearing capacity, vacuum and dispose of the waste material in an approved manner.
  - Do not discharge liquid or slurry to waterways, storm drains or directly onto ground.
  - Do not use sanitary sewer without obtaining a City of Tacoma Special Approved Discharge permit. Call Source Control at 253.591.5588 for more information.
  - Place a secure, non-collapsing, non-water collecting cover over the concrete washout facility prior to predicted wet weather to prevent accumulation and overflow of precipitation.
  - Remove and dispose of hardened concrete and return the structure to a functional condition. Concrete may be reused onsite or hauled away for disposal or recycling.
- When you remove materials from the self-installed concrete washout, build a new structure; or, if the previous structure is still intact, inspect for signs of weakening or damage, and make any necessary repairs. Re-line the structure with new plastic after each cleaning.

**3.1.22.8 Removal of Temporary Concrete Washout Facilities**

- When temporary concrete washout facilities are no longer required for the work, remove and properly dispose of the hardened concrete, slurries and liquids.
- Remove materials used to construct temporary concrete washout facilities from the site of the work and dispose of or recycle it.
- Holes, depressions or other ground disturbance caused by the removal of the temporary concrete washout facilities shall be backfilled, repaired, and stabilized to prevent erosion.

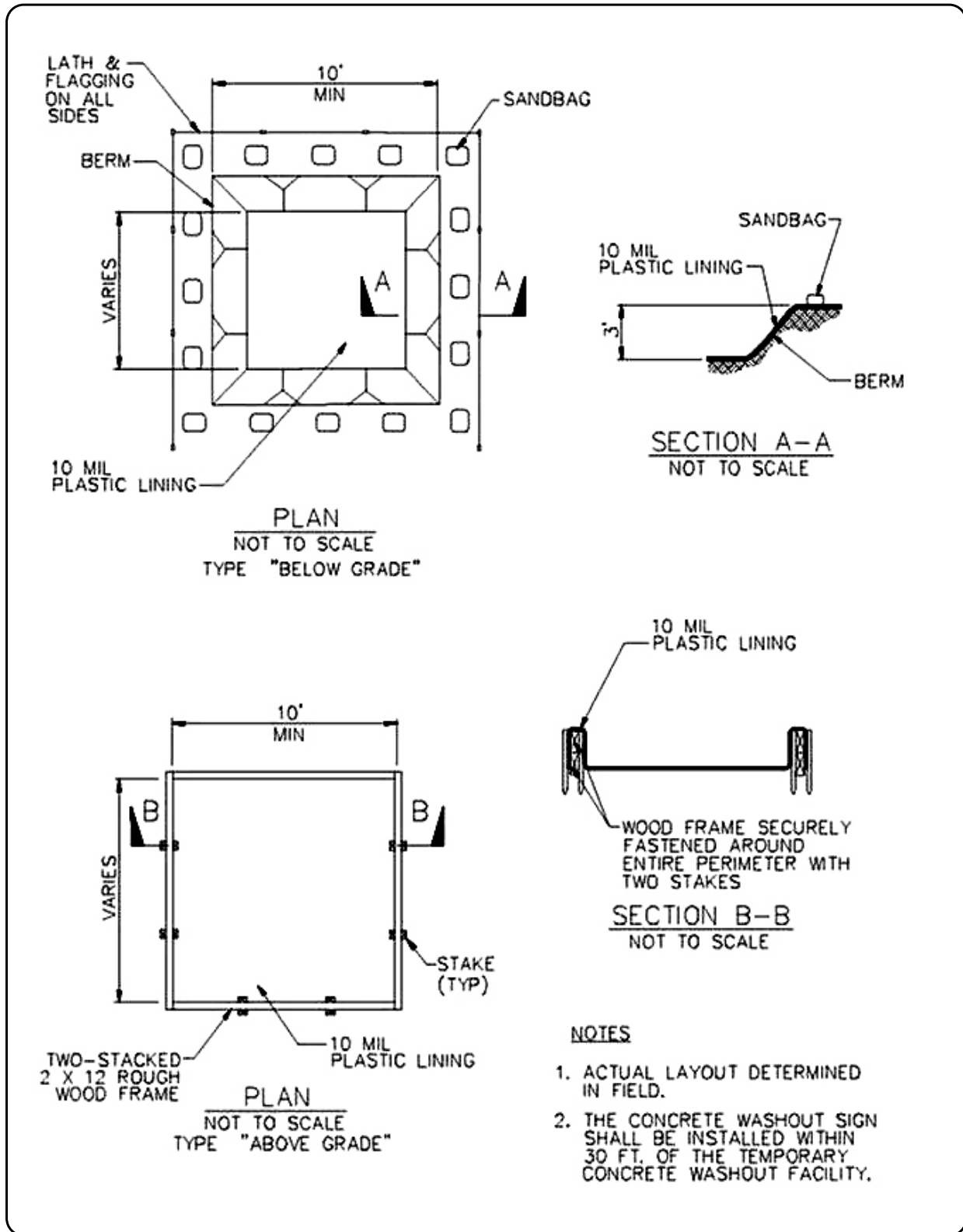
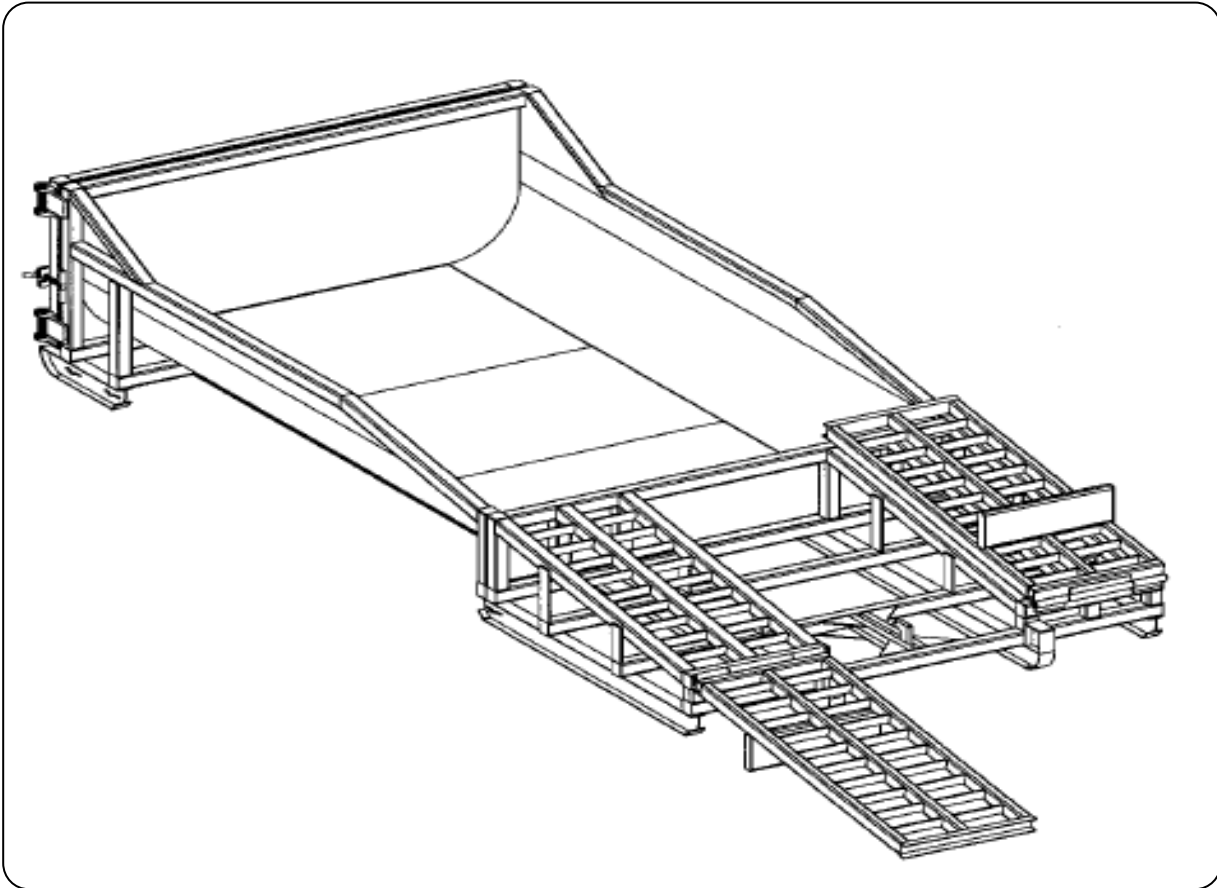


Figure 2 - 8. Temporary Concrete Washout Facility



*Figure 2 - 9. Prefabricated Concrete Washout Container with Ramp*

### **3.1.23 BMP C160: Erosion and Sediment Control Lead**

#### **3.1.23.1 Purpose**

The project proponent designates at least one person as the responsible representative in charge of erosion and sediment control (ESC) and water quality protection. The designated person shall be the erosion and sediment control (ESC) lead, who is responsible for ensuring compliance with all local, state, and federal erosion and sediment control and water quality requirements.

#### **3.1.23.2 Conditions of Use**

- An erosion and sediment control contact is required for all project sites.
- A certified erosion and sediment control lead (CESCL) or certified professional in erosion and sediment control (CPESC) is required on projects that include, but are not limited to:
  - Construction activity that disturbs one acre of land or more.
  - Construction activity that disturbs less than one acre of land, but is part of a larger common plan of development or sale that will ultimately disturb one acre of land or more.

- Heavy construction of roads, bridges, highways, airports, buildings.
- Projects near wetlands and sensitive or critical areas.
- Projects in or over water.
- Projects disturbing less than one acre must have an Erosion Sediment Control Lead (ESC) conduct inspections. The ESC Lead does not have to have CESCL or CPESC certification.
- The CESCL, CPESC, or ESC Lead shall be identified in the SWPPP and shall be onsite or on-call at all times.
- The CESCL, CPESC, or ESC Lead must be knowledgeable in the principles and practices of erosion and sediment control and have the skills to assess:
  - Site conditions and construction activities that could impact the quality of stormwater.
  - Effectiveness of erosion and sediment control measures used to control the quality of stormwater discharges.

### **3.1.23.3 Specifications**

- The CESCL lead shall:
  - Have a current certified erosion and sediment control lead (CESCL) certificate proving attendance in an erosion and sediment control training course that meets the minimum ESC training and certification requirements established by Ecology. Ecology will maintain a list of ESC training and certification providers at: [www.ecy.wa.gov/programs/wq/stormwater](http://www.ecy.wa.gov/programs/wq/stormwater).
- For additional information concerning the Certified Professional in Erosion and Sediment Control program please go to [www.cpesc.net](http://www.cpesc.net).
- The ESC lead shall have authority to act on behalf of the contractor or developer and shall be available, on call, 24 hours per day throughout the period of construction.
- The Construction SWPPP shall include the name, telephone number, email, and address of the designated ESC lead.
- An ESC lead may provide inspection and compliance services for multiple construction projects in the same geographic region.
- Duties and responsibilities of the ESC lead shall include, but are not limited to, the following:
  - Inspecting all areas disturbed by construction activities, all BMPs and all stormwater discharge points at least once every calendar week and within 24 hours of any discharge from the site. The ESC lead may reduce the inspection frequency for temporary stabilized, inactive sites to monthly.
  - Examining stormwater visually for the presence of suspended sediment, turbidity, discoloration, and oil sheen.
  - Evaluating the effectiveness of BMPs.
  - Maintaining a permit file on site at all times which includes the SWPPP and any associated permits and plans.
  - Directing BMP installation, inspection, maintenance, modification, and removal.

- Updating all project drawings and the Construction SWPPP with changes made.
- Keeping daily logs and inspection reports. Inspection reports should include:
  - Inspection date/time.
  - Weather information, general conditions during inspection, and approximate amount of precipitation since the last inspection.
  - A summary or list of all BMPs implemented, including observations of all erosion/sediment control structures or practices. The following shall be noted:
    - Locations of BMPs inspected,
    - Locations of BMPs that need maintenance,
    - Locations of BMPs that failed to operate as designed or intended, and
    - Locations where additional or different BMPs are required.
  - Visual monitoring results, including a description of discharged stormwater. The presence of suspended sediment, turbid water, discoloration, and oil sheen shall be noted, as applicable.
  - Any water quality monitoring performed during inspection.
  - General comments and notes, including a brief description of any BMP repairs, maintenance, or installations made as a result of the inspection.
- Facilitate, participate in, and take corrective actions resulting from inspections performed by outside agencies or the owner.
- Keep an inventory of equipment onsite.

### **3.1.24 BMP C161: Payment of Erosion Control Work**

#### **3.1.24.1 Purpose**

As with any construction operation, the contractor should be paid for erosion control work. Address payment for erosion control during project development and design. Identify the method of payment in the SWPPP.

Erosion control work should never be “incidental” to the contract as it is extremely difficult for the contractor to bid the work.

### **3.1.25 BMP C162: Scheduling**

#### **3.1.25.1 Purpose**

Sequencing a construction project reduces the amount and duration of soil exposed to erosion by wind, rain, runoff, and vehicle tracking.

#### **3.1.25.2 Conditions of Use**

The construction sequence schedule is an orderly listing of all major land-disturbing activities together with the necessary erosion and sedimentation control measures planned for the project.



This type of schedule guides the contractor on work to be done before other work is started so serious erosion and sedimentation problems can be avoided.

Following a specified work schedule that coordinates the timing of land-disturbing activities and the installation of control measures is perhaps the most cost-effective way of controlling erosion during construction. The removal of surface ground cover leaves a site vulnerable to accelerated erosion. Construction procedures that limit land clearing, provide timely installation of erosion and sedimentation controls, and restore protective cover quickly can significantly reduce the erosion potential of a site.

### **3.1.25.3 Design Considerations**

- Minimize construction during rainy periods.
- Schedule projects to disturb only small portions of the site at any one time. Complete grading as soon as possible. Immediately stabilize the disturbed portion before grading the next portion. Practice staged seeding in order to revegetate cut and fill slopes as the work progresses.

### 3.2 Runoff, Conveyance and Treatment BMPs

Table 2 - 10, below shows the relationship of the BMPs in Section 3.2 to the 13 Elements of a SWPPP.

**Table 2 - 10: Source Control BMPs by SWPPP Element**

BMP or Element Name	Element #3: Control Flow Rates	Element #4: Install Sediment Controls	Element #6: Protect Slopes	Element #7: Protect Drain Inlets	Element #8: Stabilize Channel and Outlets	Element #9: Control Pollutants	Element #10: Control Dewatering	Element #13: Protect BMPs
BMP C200: Interceptor Dike and Swale			X					X
BMP C201: Grass-Lined Channels			X					X
BMP C202: Channel Lining					X			
BMP C203: Water Bars	X		X				X	
BMP C204: Pipe Slope Drains			X					
BMP C205: Subsurface Drains			X					
BMP C206: Level Spreader			X				X	
BMP C207: Check Dams	X		X		X			X
BMP C208: Triangular Silt Dike			X					X
BMP C209: Outlet Protection	X				X			
BMP C220: Storm Drain Inlet Protection				X				
BMP C231: Brush Barrier		X						X
BMP C232: Gravel Filter Berm		X						

BMP or Element Name	Element #3: Control Flow Rates	Element #4: Install Sediment Controls	Element #6: Protect Slopes	Element #7: Protect Drain Inlets	Element #8: Stabilize Channel and Outlets	Element #9: Control Pollutants	Element #10: Control Dewatering	Element #13: Protect BMPs
BMP C233: Silt Fence		X						X
BMP C234: Vegetated Strip		X						X
BMP C235: Wattles	X	X						
BMP C236: Vegetated Filtration							X	
BMP C240: Sediment Trap	X	X						
BMP C241: Temporary Sediment Pond	X	X						
BMP C250: Construction Stormwater Chemical Treatment		X				X		
BMP C251: Construction Stormwater Filtration		X				X		
BMP C252: High pH Neutralization Using CO <sub>2</sub>						X		
BMP C253: pH Control for High pH Water						X		

### 3.2.1 BMP C200: Interceptor Dike and Swale

#### 3.2.1.1 Purpose

Provide a ridge of compacted soil, or a ridge with an upslope swale, at the top or base of a disturbed slope or along the perimeter of a disturbed construction area to convey stormwater. Use the dike and/or swale to intercept the runoff from unprotected areas and direct it to areas

where erosion can be controlled. This can prevent storm runoff from entering the work area or sediment-laden runoff from leaving the construction site.

### **3.2.1.2 Conditions of Use**

Where the runoff from an exposed site or disturbed slope must be conveyed to an erosion control facility that can safely convey the stormwater.

- Locate upslope of a construction site to prevent runoff from entering disturbed area.
- When placed horizontally across a disturbed slope, it reduces the amount and velocity of runoff flowing down the slope.
- Locate downslope to collect runoff from a disturbed area and direct it to a sediment basin.

### **3.2.1.3 Design and Installation Specifications**

- Stabilize dike and/or swale and channel with temporary or permanent vegetation or other channel protection during construction.
- If the design velocity of a channel to be vegetated by seeding exceeds 2 ft/sec, a temporary channel liner is required. See Figure 2 - 11.
- Channel requires a positive grade for drainage; steeper grades require channel protection and check dams.
- Review construction for areas where overtopping may occur.
- Should be used at the top of new fill before vegetation is established.
- May be used as a permanent diversion channel to carry the runoff.
- Sub-basin tributary area should be one acre or less.
- Design capacity for the peak flow from a 10-year, 24-hour storm event assuming a Type 1A rainfall distribution (3-inches) for temporary facilities. Alternatively, use the 10-year return period flowrate, indicated by WWHM assuming a 15 minute timestep. Design capacity for the peak flow from a 25-year, 24-hour storm for permanent facilities.

**Interceptor Dikes**

- Interceptor dikes shall meet the following criteria:
 

Top Width	2 feet minimum.
Height	1.5 feet minimum on berm.
Side Slope	2:1 or flatter.
Grade	Depends on topography, however, dike system minimum is 0.5% and maximum is 1%
Compaction	Minimum of 90 percent ASTM D698 standard proctor.
  
- Horizontal Spacing of Interceptor Dikes:
 

Average Slope	Slope Percent	Flowpath Length
20H:1V or less	3-5%	300 feet
(10 to 20)H:1V	5-10%	200 feet
(4 to 10)H:1V	10-25%	100 feet
(2 to 4)H:1V	25-50%	50 feet
  
- Stabilization depends on velocity and reach.
 

Slopes <5%	Seed and mulch applied within 5 days of dike construction (see BMP C121, Mulching).
Slopes 5 - 40%	Dependent on runoff velocities and dike materials. Stabilization should be done immediately using either sod or riprap or other measures to avoid erosion. See Volume 3, Section 3.4 for additional guidance on channel protection.
  
- The upslope side of the dike shall provide positive drainage to the dike outlet. No erosion shall occur at the outlet. Provide energy dissipation measures as necessary. Sediment-laden runoff must be released through a sediment trapping facility.
- Minimize construction traffic over temporary dikes. Use temporary cross culverts for channel crossing.

**Interceptor Swales**

- Interceptor swales shall meet the following criteria:
 

Bottom Width	2 feet minimum; the bottom shall be level.
Depth	1-foot minimum.
Side Slope	2H:1V or flatter
Grade	Maximum 5 percent, with positive drainage to a suitable outlet (such as a sediment pond).
Stabilization	Seed as per <i>BMP C120, Temporary and Permanent Seeding</i> , or <i>BMP C202, Channel Lining</i> , 12 inches thick of riprap pressed into the bank and extending at least 8 inches vertical from the bottom.
  
- Inspect diversion dikes and interceptor swales once a week and after every rainfall. Immediately remove sediment from the flow area.
- Repair damage caused by construction traffic or other activity before the end of each working day.
- Check outlets and make timely repairs as needed to avoid gully formation. When the area below the temporary diversion dike is permanently stabilized, remove the dike and fill and stabilize the channel to blend with the natural surface.

## 3.2.2 BMP C201: Grass-Lined Channels

### 3.2.2.1 Purpose

To provide a channel with a vegetative lining for conveyance of runoff. See Figure 2 - 10 for typical grass-lined channels.

### 3.2.2.2 Conditions of Use

This practice applies to construction sites where concentrated runoff needs to be contained to prevent erosion or flooding.

- When a vegetative lining can provide sufficient stability for the channel cross section and lower velocities of water (normally dependent on grade). This means that the channel slopes are generally less than 5 percent and space is available for a relatively large cross section.
- Typical uses include roadside ditches, channels at property boundaries, outlets for diversions, and other channels and drainage ditches in low areas.
- Channels that will be vegetated should be installed before major earthwork and hydroseeded with a bonded fiber matrix (BFM). The vegetation should be well established (i.e., 75 percent cover) before water is allowed to flow in the ditch. With channels that will have high flows, erosion control blankets should be installed over the hydroseed. If vegetation cannot be established from seed before water is allowed in the ditch, sod should be installed in the bottom of the ditch in lieu of hydromulch and blankets.

### 3.2.2.3 Design and Installation Specifications

Locate the channel where it can conform to the topography and other features such as roads.

- Locate them to use natural drainage systems to the greatest extent possible.
- Avoid sharp changes in alignment or bends and changes in grade.
- Do not reshape the landscape to fit the drainage channel.
- Base the maximum design velocity on soil conditions, type of vegetation, and method of revegetation, but at no times shall velocity exceed 5 feet/second. The channel shall not be overtopped by the peak runoff from a 10-year, 24-hour storm event, assuming a type 1A rainfall distribution (3.0-inches). Alternatively, use the 10-year return period flowrate, indicated by WWHM assuming a 15 minute timestep to determine a flow rate which the channel must contain.
- An **established** grass or vegetated lining is required before the channel can be used to convey stormwater, unless stabilized with nets or blankets.
- If the design velocity of a channel to be vegetated by seeding exceeds 2 ft/sec, a temporary channel liner is required. See Figure 2 - 11.
- Remove check dams when the grass has matured sufficiently to protect the ditch or swale unless the slope of the swale is greater than 4 percent. Seed and mulch the area beneath the check dams immediately after dam removal.
- If vegetation is established by sodding, the permissible velocity for established vegetation may be used and no temporary liner is needed.
- Do not subject grass-lined channel to sedimentation from disturbed areas. Use sediment-trapping BMPs upstream of the channel.

- **V-shaped grass channels** generally apply where the quantity of water is small, such as in short reaches along roadsides. The V-shaped cross section is least desirable because it is difficult to stabilize the bottom where velocities may be high.
- **Trapezoidal grass channels** are used where runoff volumes are large and slope is low so that velocities are nonerosive to vegetated linings. (**Note:** it is difficult to construct small parabolic shaped channels.)
- Subsurface drainage, or riprap channel bottoms, may be necessary on sites that are subject to prolonged wet conditions due to long duration flows or a high water table.
- Provide outlet protection at culvert ends and at channel intersections.
- Grass channels, at a minimum, should carry peak runoff for temporary construction drainage facilities from the 10-year, 24-hour storm event assuming a Type 1A rainfall distribution (3.0-inches) without eroding. Where flood hazard exists, increase the capacity according to the potential damage.
- Grassed channel side slopes generally are constructed 3:1 or flatter to aid in the establishment of vegetation and for maintenance.
- Construct channels a minimum of 0.2 foot larger around the periphery to allow for soil bulking during seedbed preparations and sod buildup.

#### **3.2.2.4 Maintenance Standards**

- During the establishment period, check grass-lined channels after every rainfall.
- After grass is established, periodically check the channel; check the channel after every heavy rainfall event. Immediately make repairs.
- It is particularly important to check the channel outlet and all road crossings for bank stability and evidence of piping or scour holes.
- Remove all significant sediment accumulations to maintain the designed carrying capacity. Keep the grass in a healthy, vigorous condition at all times, since it is the primary erosion protection for the channel.

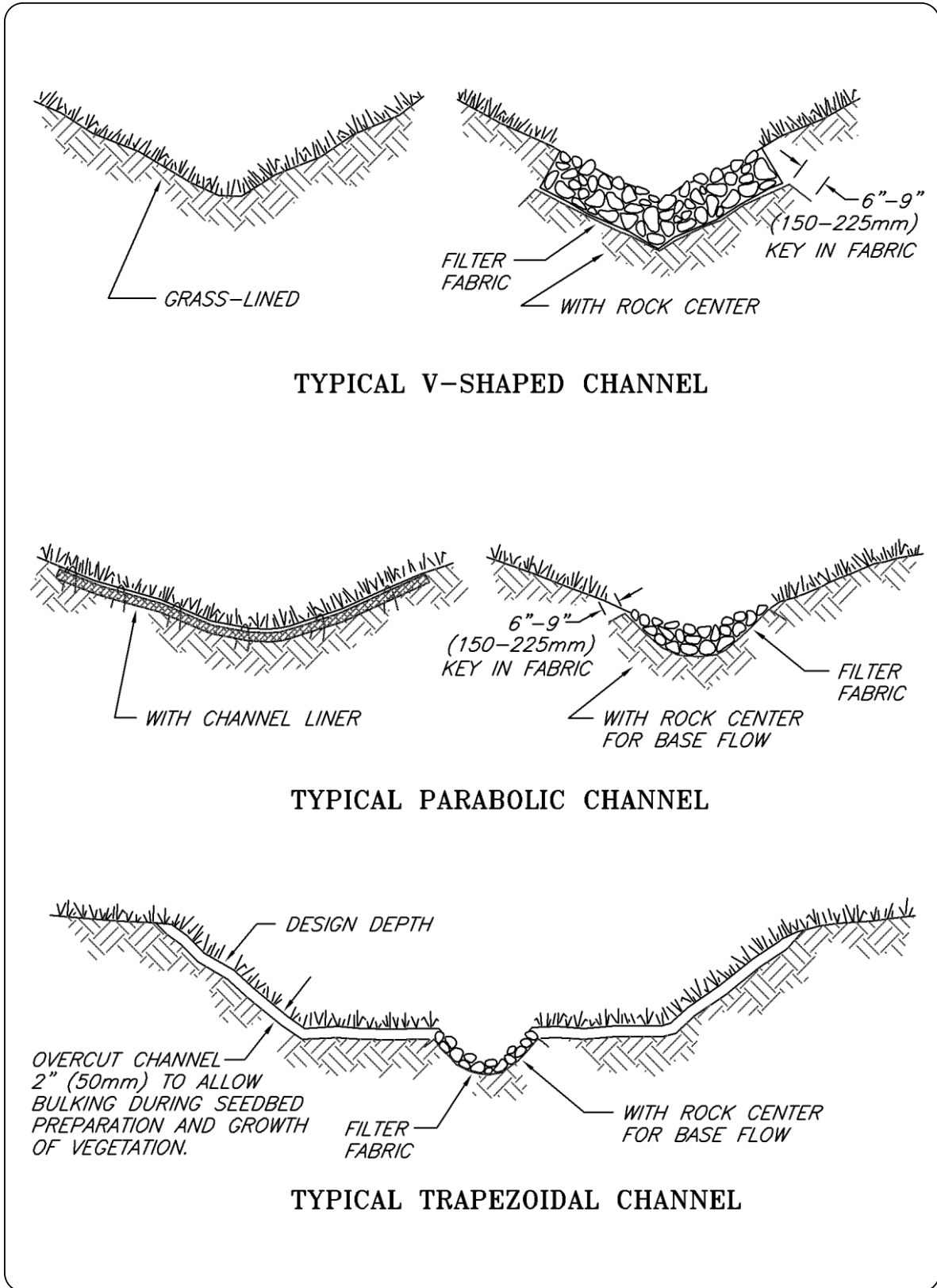


Figure 2 - 10. Typical Grass-Lined Channels



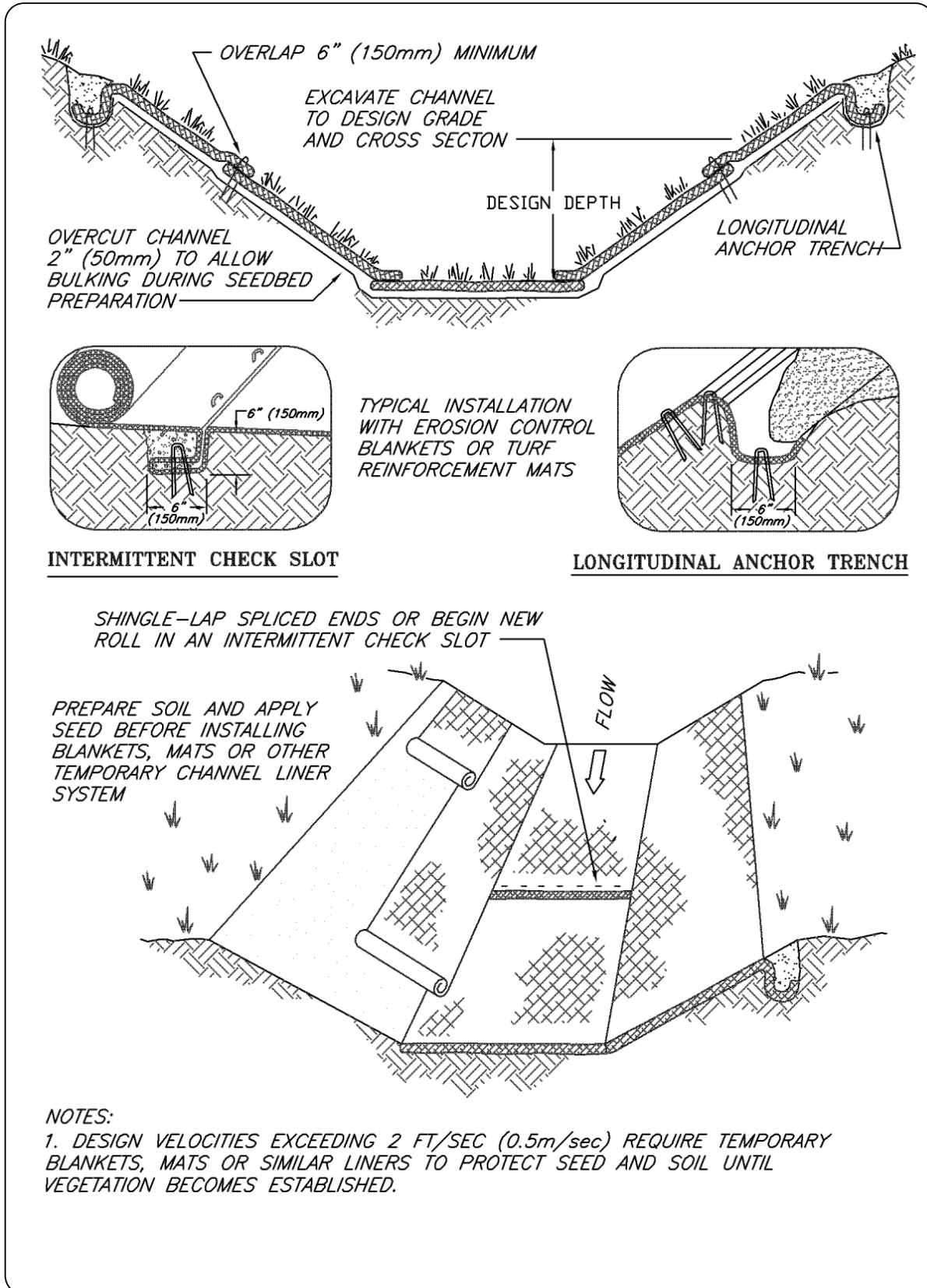


Figure 2 - 11. Temporary Channel Liners

### **3.2.3 BMP C202: Channel Lining**

#### **3.2.3.1 Purpose**

To protect erodible channels by providing a channel liner using either blankets or riprap.

#### **3.2.3.2 Conditions of Use**

- When natural soils or vegetated stabilized soils in a channel are not adequate to prevent channel erosion.
- When a permanent ditch or pipe system is to be installed and a temporary measure is needed.
- In almost all cases, synthetic and organic coconut blankets are more effective than riprap for protecting channels from erosion. Blankets can be used with and without vegetation. Blanketed channels can be designed to handle any expected flow and longevity requirement. Some synthetic blankets have a predicted life span of 50 years or more, even in sunlight.
- The Federal Highway Administration recommends not using flexible liners whenever the slope exceeds 10 percent or the shear stress exceeds 8 pounds per square foot.

#### **3.2.3.3 Design and Installation Specifications**

- See BMP C122 for information on blankets.
- Since riprap is used where erosion potential is high, construction must be sequenced so the riprap is put in place with the minimum possible delay (see Figure 2 - 12).
- Only disturb areas where riprap is to be placed if final preparation and placement of the riprap can immediately follow the initial disturbance. Where riprap is used for outlet protection, place the riprap before or in conjunction with the construction of the pipe or channel so it is in place when the pipe or channel begins to operate.
- The designer, after determining the appropriate riprap size for stabilization, shall consider that size to be a minimum size and then, based on riprap gradations actually available in the area, select the size or sizes that equal or exceed the minimum size. Consider the possibility of drainage structure damage by children when selecting a riprap size, especially if there is nearby water or a gully in which to toss the stones. See Volume 3, Section 3.4 for additional channel protection guidance.
- Use field stone or quarry stone of approximately rectangular shape for the riprap. The stone shall be hard and angular and of such quality that it will not disintegrate on exposure to water or weathering and shall be suitable in all respects for the purpose intended.
- Rubble concrete may be used, provided it has a density of at least 150 pounds per cubic foot and otherwise meets the requirement of this standard and specification.
- Place a lining of engineering filter fabric (geotextile) between the riprap and the underlying soil surface to prevent soil movement into or through the riprap. The geotextile should be keyed in at the top of the bank.
- Do not use filter fabric on slopes steeper than 1-1/2H:1V as slippage may occur. It should be used in conjunction with a layer of coarse aggregate (granular filter blanket) when the riprap to be placed is 12 inches and larger.

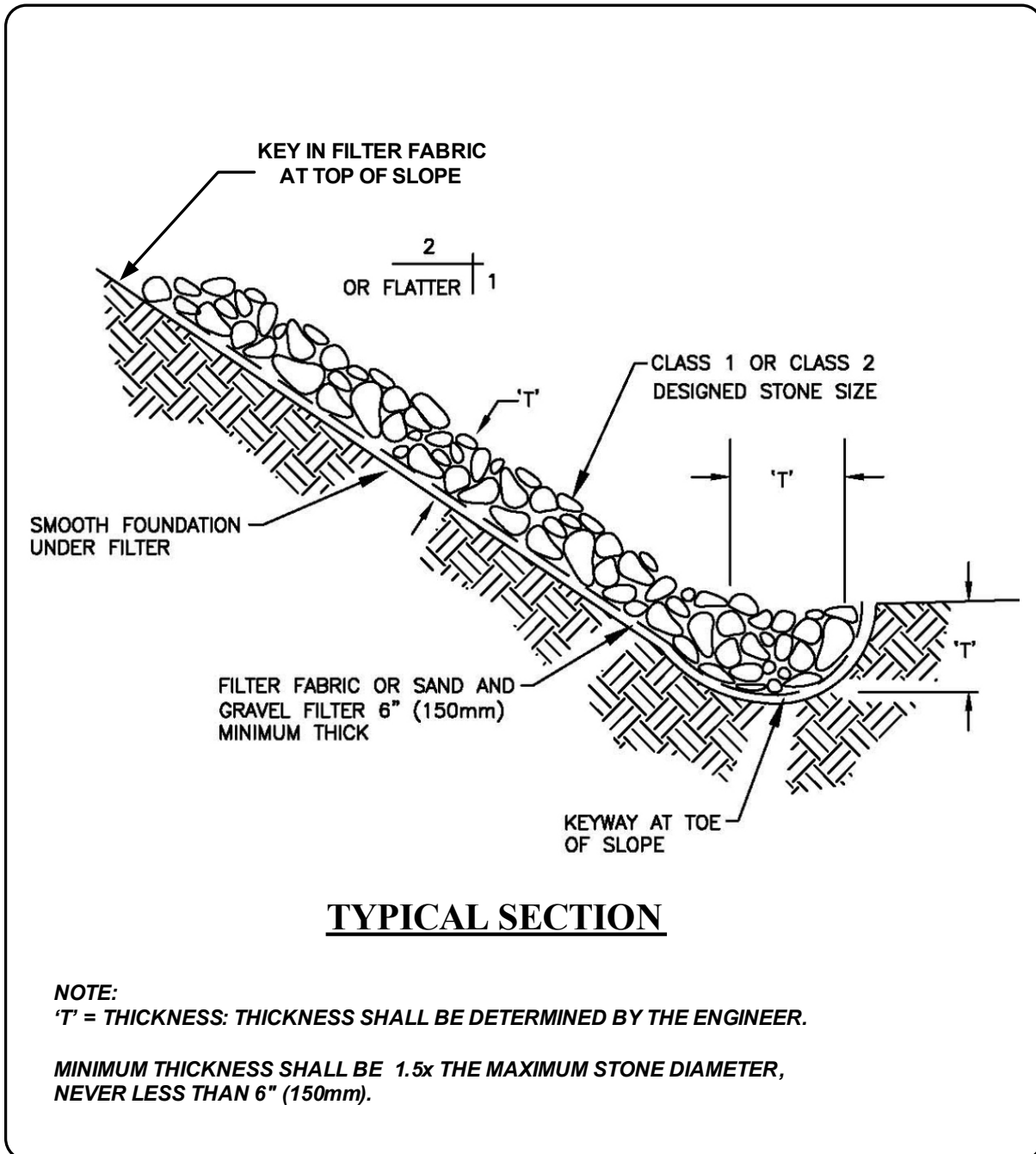


Figure 2 - 12. Soil Erosion Protection – Rip Rap Protection

### 3.2.4 BMP C203: Water Bars

#### 3.2.4.1 Purpose

A small ditch or ridge of material is constructed diagonally across a road or right-of-way to divert stormwater runoff from the road surface, wheel tracks, or a shallow road ditch.

**3.2.4.2 Conditions of Use**

Clearing right-of-way and construction of access for power lines, pipelines, and other similar installations often require long, narrow right-of-ways over sloping terrain. Disturbance and compaction promotes gully formation in these cleared strips by increasing the volume and velocity of runoff. Gully formation may be especially severe in tire tracks and ruts. To prevent gullying, runoff can often be diverted across the width of the right-of-way to undisturbed areas by using small predesigned diversions.

Give special consideration to each individual outlet area, as well as to the cumulative effect of added diversions. Use gravel to stabilize the diversion where significant vehicular traffic is anticipated.

**3.2.4.3 Design and Installation Specifications**

- Height: 8-inch minimum measured from the channel bottom to the top of the ridge.
- Side slope of channel: 2H:1V maximum; 3H:1V or flatter when vehicles will cross.
- Base width of ridge: 6-inch minimum.
- Locate them to use natural drainage systems and to discharge into well vegetated stable areas.
- Guideline for Spacing:

Slope %	Spacing (ft)
< 5	125
5 - 10	100
10 - 20	75
20 – 35	50
> 35	Use rock lined ditch

- Grade of water bar and angle: Select angle that results in ditch slope of less than 2 percent.
- Install as soon as clearing and grading is complete. Reconstruct when construction is complete on a section when utilities are being installed.
- Compact the ridge when installed.
- Stabilize, seed, and mulch portions that are not subject to traffic. Gravel areas crossed by vehicles.

### **3.2.4.4 Maintenance Standards**

- Periodically inspect right-of-way diversions for wear and after every heavy rainfall inspect for erosion damage.
- Immediately remove sediment from the flow area and repair the dike.
- Check outlet areas and make timely repairs as needed.
- When permanent road drainage is established and the area above the temporary right-of-way diversion is permanently stabilized, remove the dike and fill the channel to blend with the natural ground, and appropriately stabilize the disturbed area.

### **3.2.5 BMP C204: Pipe Slope Drains**

#### **3.2.5.1 Purpose**

To use a pipe to convey stormwater anytime water needs to be diverted away from or over bare soil to prevent gullies, channel erosion, and saturation of slide-prone soils.

#### **3.2.5.2 Conditions of Use**

Pipe slope drains should be used when a temporary or permanent stormwater conveyance is needed to move the water down a steep slope to avoid erosion (Figure 2 - 13).

On highway projects, pipe slope drains should be used at bridge ends to collect runoff and pipe it to the base of the fill slopes along bridge approaches. These can be designed into a project and included as bid items. Another use on road projects is to collect runoff from pavement and pipe it away from side slopes. These are useful because there is generally lag time between having the first lift of asphalt installed and the curbs, gutters, and permanent drainage installed. Used in conjunction with sand bags or other temporary diversion devices, these will prevent sediment from leaving a project.

Water can be collected; channeled with sand bags, Triangular Silt Dikes, berms, or other material; and piped to temporary sediment ponds.

Pipe slope drains can be:

- Connected to new catch basins and used temporarily until all permanent piping is installed;
- Used to drain water collected from aquifers exposed on cut slopes and convey it to the base of the slope;
- Used to collect clean runoff from plastic sheeting and direct it away from exposed soil;
- Installed in conjunction with silt fence to drain collected water to a controlled area;
- Used to divert small seasonal streams away from construction. They have been used successfully on culvert replacement and extension jobs. Large flex pipe can be used on larger streams during culvert removal, repair, or replacement; and,
- Connected to existing downspouts and roof drains and used to divert water away from work areas during building renovation, demolition, and construction projects.

There are now several commercially available collectors that are attached to the pipe inlet and help prevent erosion at the inlet.

### 3.2.5.3 Design and Installation Specifications

Size the pipe to convey the flow. The capacity for temporary drains shall be sufficient to handle the peak flow from a 10-year, 24-hour storm event assuming a Type 1A rainfall distribution (3.0-inches). Alternatively, use the 10-year return period flowrate, indicated by WWHM assuming a 15 minute timestep. Size permanent pipe slope drains using the guidance in Volume 3, Chapter 3.

- Use care in clearing vegetated slopes for installation.
- Re-establish cover immediately on areas disturbed by installation.
- Use temporary drains on new cut or fill slopes.
- Use diversion dikes or swales to collect water at the top of the slope.
- Ensure that the entrance area is stable and large enough to direct flow into the pipe.
- Piping of water through the berm at the entrance area is a common failure mode.
- The entrance shall consist of a standard flared end section for culverts 12 inches and larger with a minimum 6-inch metal toe plate to prevent runoff from undercutting the pipe inlet. The slope of the entrance shall be at least 3 percent. Sand bags may also be used at pipe entrances as a temporary measure.
- Thoroughly compact the soil around and under the pipe and entrance section to prevent undercutting.
- Securely connect the flared inlet section to the slope drain and have watertight connecting bands.
- Securely fasten, fuse or have gasketed, watertight fittings for the slope drain sections, and securely anchor them into the soil.
- Install thrust blocks anytime 90 degree bends are utilized. Depending on size of pipe and flow, these can be constructed with sand bags, straw bales staked in place, "T" posts and wire, or ecology blocks.
- Pipe needs to be secured along its full length to prevent movement. This can be done with steel "T" posts and wire. A post is installed on each side of the pipe and the pipe is wired to them. This should be done every 10-20 feet of pipe length, depending on the size of the pipe and quantity of water to be diverted.
- Use interceptor dikes to direct runoff into a slope drain. Ensure the height of the dike is at least 1 foot higher at all points than at the top of the inlet pipe.
- Stabilize the area below the outlet with a riprap apron (see BMP C209 Outlet Protection for the appropriate outlet material). For permanent installations, protect the outfall using guidance in Volume 3, Section 3.5.
- If the pipe slope drain is conveying sediment-laden water, direct all flows into the sediment trapping facility.
- Materials specifications for any permanent piped system shall conform to Volume 3, Chapter 3.

### 3.2.5.4 Maintenance Standards

- Check inlet and outlet points regularly, especially after storms.
- The inlet should be free of undercutting, and no water should be going around the point of entry. If there are problems, the headwall should be reinforced with compacted earth or sand bags.

- The outlet point should be free of erosion and installed with appropriate outlet protection.
- For permanent installations, inspect pipe periodically for vandalism and physical distress such as slides and wind-throw.
- Normally the pipe slope is so steep that clogging is not a problem with smooth wall pipe; however, debris may become lodged in the pipe.

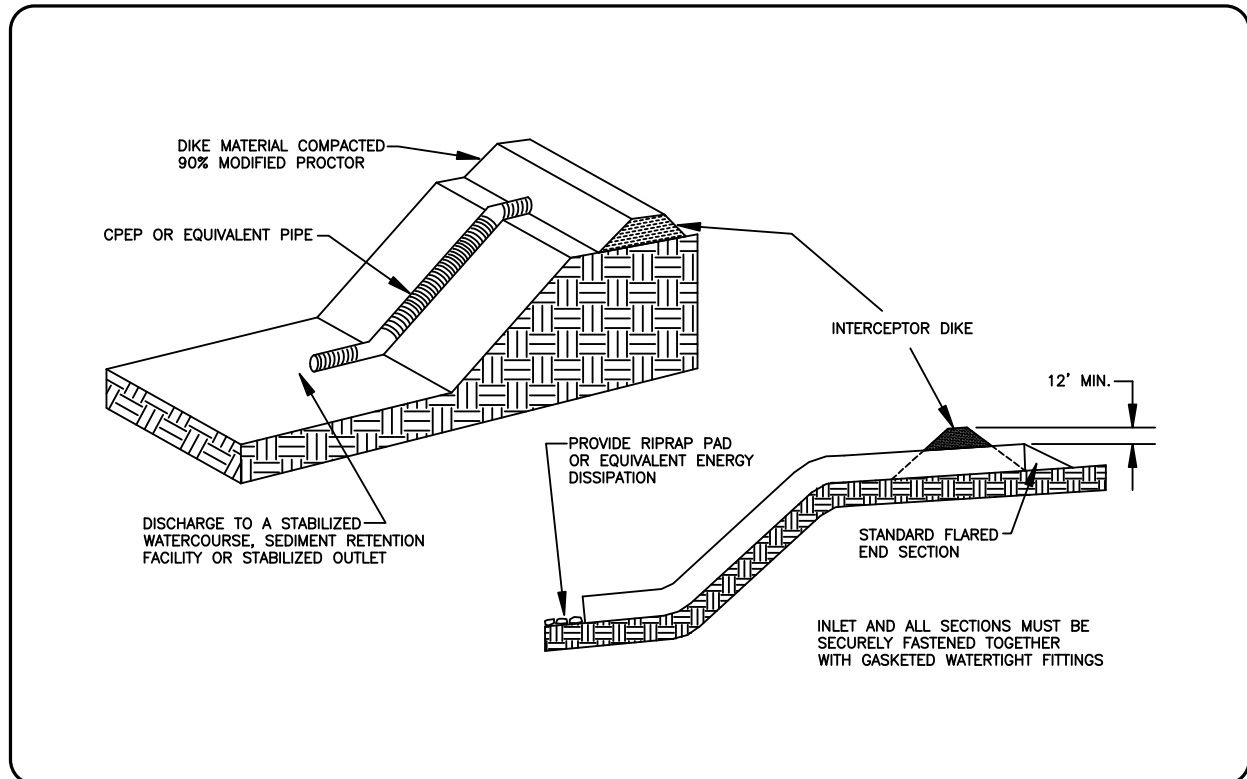


Figure 2 - 13. Pipe Slope Drains

### 3.2.6 BMP C205: Subsurface Drains

#### 3.2.6.1 Purpose

To intercept, collect, and convey groundwater to a satisfactory outlet, using a perforated pipe or conduit below the ground surface. Subsurface drains are also known as “French drains.” The perforated pipe provides a dewatering mechanism to drain excessively wet soils, provide a stable base for construction, improve stability of structures with shallow foundations, or to reduce hydrostatic pressure to improve slope stability.

#### 3.2.6.2 Conditions of Use

Use when excessive water must be removed from the soil. The soil permeability, depth to water table, and impervious layers are all factors which may govern the use of subsurface drains.

#### 3.2.6.3 Design and Installation Specifications

- Relief drains

- Are used either to lower the water table in large, relatively flat areas, improve the growth of vegetation, or to remove surface water.
- Are installed along a slope and drain in the direction of the slope.
- Can be installed in a grid pattern, a herringbone pattern, or a random pattern.
- **Interceptor drains**
  - Are used to remove excess groundwater from a slope, stabilize steep slopes, and lower the water table immediately below a slope to prevent the soil from becoming saturated.
  - Are installed perpendicular to a slope and drain to the side of the slope.
  - Usually consist of a single pipe or series of single pipes instead of a patterned layout.
- **Depth and spacing considerations for interceptor drains**
  - The depth of an interceptor drain is determined primarily by the depth to which the water table is to be lowered or the depth to a confining layer. For practical reasons, the maximum depth is usually limited to 6 feet, with a minimum cover of 2 feet to protect the conduit.
  - The soil should have depth and sufficient permeability to permit installation of an effective drainage system at a depth of 2 to 6 feet.
  - An adequate outlet for the drainage system must be available either by gravity or pumping.
  - The quantity and quality of discharge needs to be accounted for in the receiving stream (additional detention may be required).
  - This standard does not apply to subsurface drains for building foundations or deep excavations.
- The capacity of an interceptor drain is determined by calculating the maximum rate of groundwater flow to be intercepted. Therefore, it is good practice to make complete subsurface investigations, including hydraulic conductivity of the soil, before designing a subsurface drainage system.



- **Drain sizing considerations**
  - Size subsurface drains to carry the required capacity without pressure flow. The minimum diameter for a subsurface drain is 4 inches.
  - The minimum velocity required to prevent silting is 1.4 feet per second. Grade the line to achieve this velocity at a minimum. The maximum allowable velocity using a sand-gravel filter or envelope is 9 feet per second.
- Use filter material and fabric around all drains for proper bedding and filtration of fine materials. Envelopes and filters should surround the drain to a minimum of 3-inch thickness.
- Empty the outlet of the subsurface drain into a sediment pond or other appropriate sediment removal device. If free of sediment, it can empty into a receiving channel, swale, or stable vegetated area adequately protected from erosion and undermining.
- Construct the trench on a continuous grade with no reverse grades or low spots.
- Stabilize soft or yielding soils under the drain with gravel or other suitable material.
- Backfill immediately after placement of the pipe. Do not allow sections of pipe to remain uncovered overnight or during a rainstorm. Place backfill material in the trench in such a manner that the drain pipe is not displaced or damaged.
- Do not install permanent drains near trees as tree roots may clog the lines. Use solid pipe with watertight connections where necessary to pass a subsurface drainage system through a stand of trees.
- **Outlet considerations**
  - Ensure that the outlet of a drain empties into a channel or other watercourse above the normal water level.
  - Secure an animal guard to the outlet end of the pipe to keep out rodents.
  - Use at least 10 feet of corrugated metal, cast iron, or heavy-duty plastic without perforations outlet pipe. Do not use an envelope or filter material around the outlet pipe, and bury at least two-thirds of the pipe length.
  - When outlet velocities exceed those allowable for the receiving stream, provide outlet protection.

#### **3.2.6.4 Maintenance Standards**

- Check the subsurface drains periodically to ensure that they are free-flowing and not clogged with sediment or roots.
- Keep the outlet clean and free of debris.
- Keep surface inlets open and free of sediment and other debris.
- Trees located too close to a subsurface drain often clog the system with their roots. If a drain becomes clogged, relocate the drain or remove the trees as a last resort. Plan the placement of the drain to minimize this problem.
- Where drains are crossed by heavy vehicles, check the line to ensure that it is not crushed and use pipe material that can handle traffic loads.

### **3.2.7 BMP C206: Level Spreader**

#### **3.2.7.1 Purpose**

To provide a temporary outlet for dikes and diversions consisting of an excavated depression constructed at zero grade across a slope. To convert concentrated runoff to sheet flow and release it onto areas stabilized by existing vegetation or an engineered filter strip.

#### **3.2.7.2 Conditions of Use**

- Used when a concentrated flow of water needs to be dispersed over a large area with existing stable vegetation.
- Items to consider are:
  - What is the risk of erosion or damage if the flow may become concentrated?
  - Is an easement required if discharged to adjoining property?
  - Most of the flow should be as groundwater and not as surface flow.
  - Is there an unstable area downstream that cannot accept additional groundwater?
- Use only where the slopes are gentle, the water volume is relatively low, and the soil will adsorb most of the low flow events.

#### **3.2.7.3 Design and Installation Specifications**

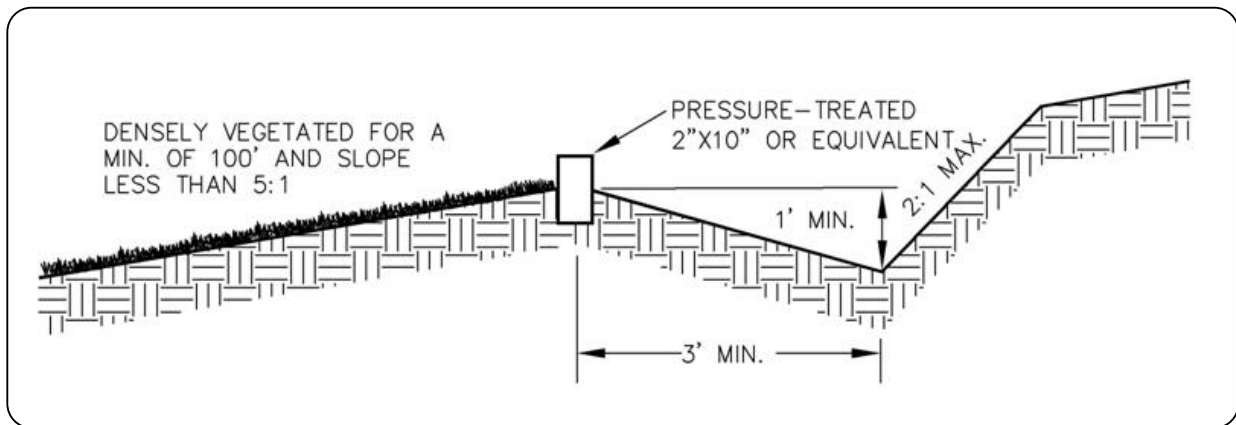
- Use above undisturbed areas that are stabilized by existing vegetation.
- If the level spreader has any low points, flow will concentrate, create channels and may cause erosion.
- Discharge area below the outlet must be uniform with a slope of less than 20%.
- Construct outlet level in a stable, undisturbed soil profile (not on fill).
- Do not allow the runoff to reconcentrate after release unless intercepted by another downstream measure.
- The grade of the channel for the last 20 feet of the dike or interceptor entering the level spreader shall be less than or equal to 1 percent. The grade of the level spreader shall be 0 percent to ensure uniform spreading of storm runoff.
- A 6-inch high gravel berm placed across the level lip shall consist of washed crushed rock, 2- to 4-inch or 3/4-inch to 1½-inch size.
- Calculate the spreader length by estimating the peak flow expected from the 10-year, 24-hour design storm event assuming a type 1A rainfall distribution (3.0-inches). The length of the spreader shall be a minimum of 15 feet for 0.1 cubic feet per second and shall be 10 feet for each 0.1 cubic feet per second there after to a maximum of 0.5 cubic feet per second per spreader. Use multiple spreaders for higher flows.
- The width of the spreader should be at least 6 feet.
- The depth of the spreader as measured from the lip should be at least 6 inches and it should be uniform across the entire length.
- Level spreaders shall be setback a minimum of 5 feet from the property line unless there is an easement for flow.
- Level spreaders, when installed every so often in grassy swales, keep the flows from concentrating. Materials that can be used include sand bags, lumber, logs, concrete, and pipe. To function properly, the material needs to be installed level and on contour.

Figure 2 - 14 and Figure 2 - 15 provide a cross-section and a detail of a level spreader. A capped perforated pipe can also be used as a spreader.

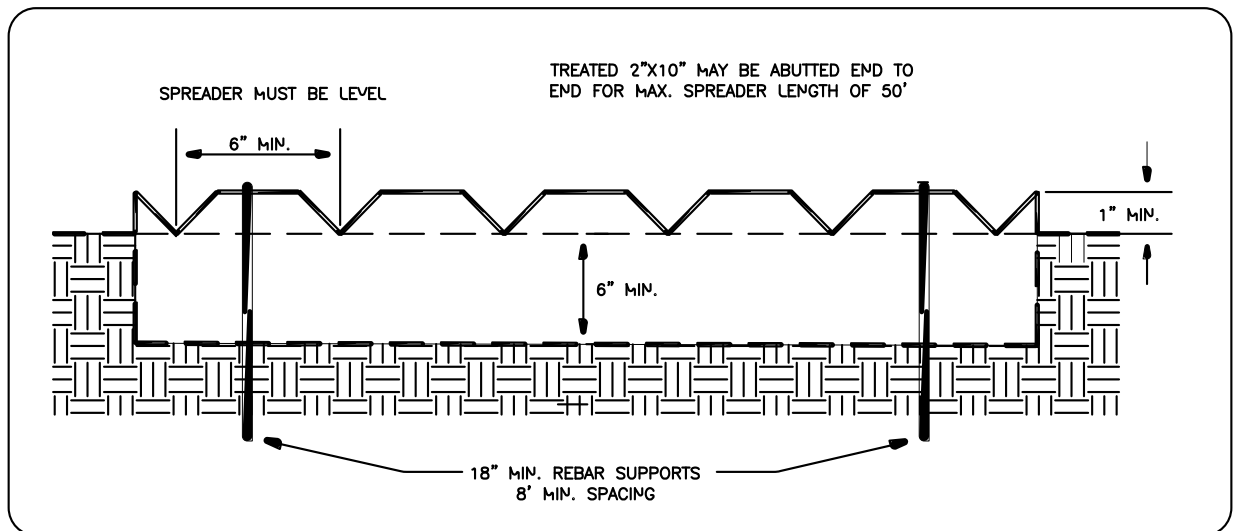
**3.2.7.4 Maintenance Standards**

The spreader should be inspected after every runoff event to ensure proper function.

- The contractor should avoid the placement of any material on the structure and should prevent construction traffic from crossing over the structure.
- If the spreader is damaged by construction traffic, immediately repair it.



**Figure 2 - 14. Cross-Section of a Level Spreader**



**Figure 2 - 15. Detail of a Level Spreader**

### **3.2.8 BMP C207: Check Dams**

#### **3.2.8.1 Purpose**

Construction of small dams across a swale or ditch reduces the velocity of concentrated flow and dissipates energy at the check dam.

#### **3.2.8.2 Conditions of Use**

- Where temporary channels or permanent channels are not yet vegetated, channel lining is infeasible, and velocity checks are required.
- Do not place check dams in streams unless approved by the State Department of Fish and Wildlife. Do not place check dams in wetlands without approval from the City of Tacoma Planning and Development Services and other appropriate state agencies.
- Do not place check dams below the expected backwater from any salmonid bearing water between September 15 and June 15 to ensure that there is no loss of high flow refuge habitat for overwintering juvenile salmonids and emergent salmonid fry.

#### **3.2.8.3 Design and Installation Specifications**

- Construct rock check dams from appropriately sized rock; rock or pea-gravel filled bags; or other products intended for this purpose. The rock used must be large enough to stay in place given the expected design flow through the channel. The rock must be placed by hand or by mechanical means (no dumping of rock to form dam) to achieve complete coverage of the ditch or swale and to ensure that the center of the dam is lower than the edges.
- Before installing check dams bypass upstream flow away from the work area.
- Whatever material is used, the dam should form a triangle when viewed from the side. This prevents undercutting as water flows over the face of the dam rather than falling directly onto the ditch bottom.
- Check dams in association with sumps work more effectively at slowing flow and retaining sediment than just a check dam alone. A deep sump should be provided immediately upstream of the check dam.
- In some cases, if carefully located and designed, check dams can remain as permanent installations with very minor regrading. They may be left as either spillways, in which case accumulated sediment would be graded and seeded, or as check dams to prevent further sediment from leaving the site.
- Check dams can be constructed of either rock or pea-gravel filled bags. Numerous new products are also available for this purpose. They tend to be re-usable, quick and easy to install, effective, and cost efficient.
- Check dams should be placed perpendicular to the flow of water.
- The maximum spacing between the dams shall be such that the toe of the upstream dam is at the same elevation as the top of the downstream dam.
- Keep a maximum height of 2 feet at the center of the dam.
- Keep the center of the check dam at least 12 inches lower than the outer edges at natural ground elevation.
- Keep the side slopes of the check dam at 2H:1V or flatter.
- Key the stone into the ditch banks and extend it beyond the abutments a minimum of 18 inches to avoid washouts from overflow around the dam.

- Use filter fabric foundation under a rock or sand bag check dam. If a blanket ditch liner is used, this is not necessary. A piece of organic or synthetic blanket cut to fit will also work for this purpose.
- In the case of grass-lined ditches and swales, remove all check dams and accumulated sediment when the grass has matured sufficiently to protect the ditch or swale - unless the slope of the swale is greater than 4 percent. Seed and mulch the area beneath the check dams immediately after dam removal.
- Ensure that channel appurtenances, such as culvert entrances below check dams, are not subject to damage or blockage from displaced stones. Figure 2 - 16 depicts a typical rock check dam.

#### **3.2.8.4 Maintenance Standards**

- Monitor check dams for performance and sediment accumulation during and after each runoff producing rainfall. Remove sediment when it reaches one half the sump depth.
- Anticipate submergence and deposition above the check dam and erosion from high flows around the edges of the dam.
- If significant erosion occurs between dams, install a protective riprap liner in that portion of the channel.

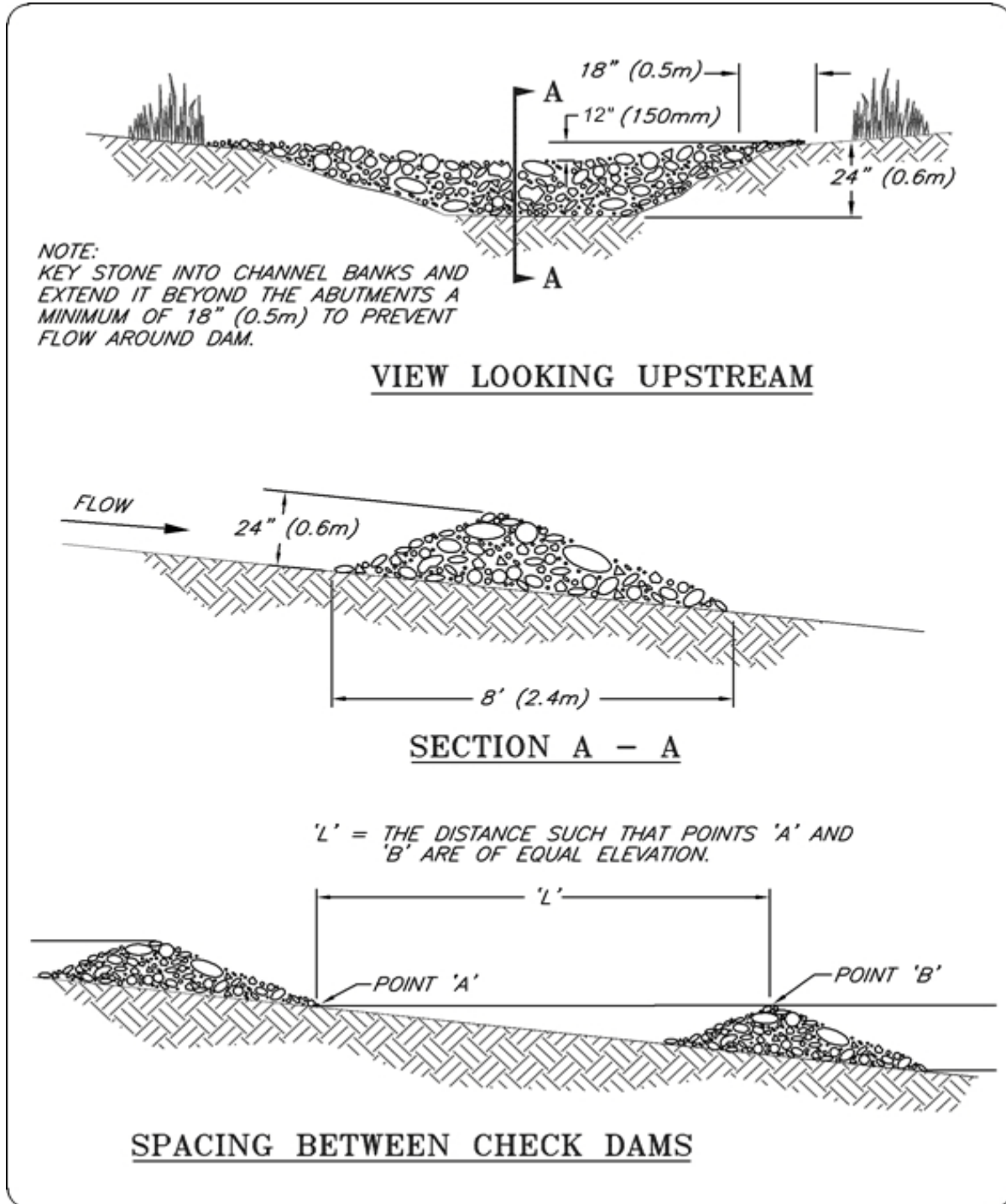


Figure 2 - 16. Check Dams

### **3.2.9 BMP C208: Triangular Silt Dike (Geotextile-Encased Check Dam)**

#### **3.2.9.1 Purpose**

Triangular silt dikes (TSDs) may be used as check dams, for perimeter protection, for temporary soil stockpile protection, for drop inlet protection, or as a temporary interceptor dike (refer to Figure 2 - 17).

#### **3.2.9.2 Conditions of Use**

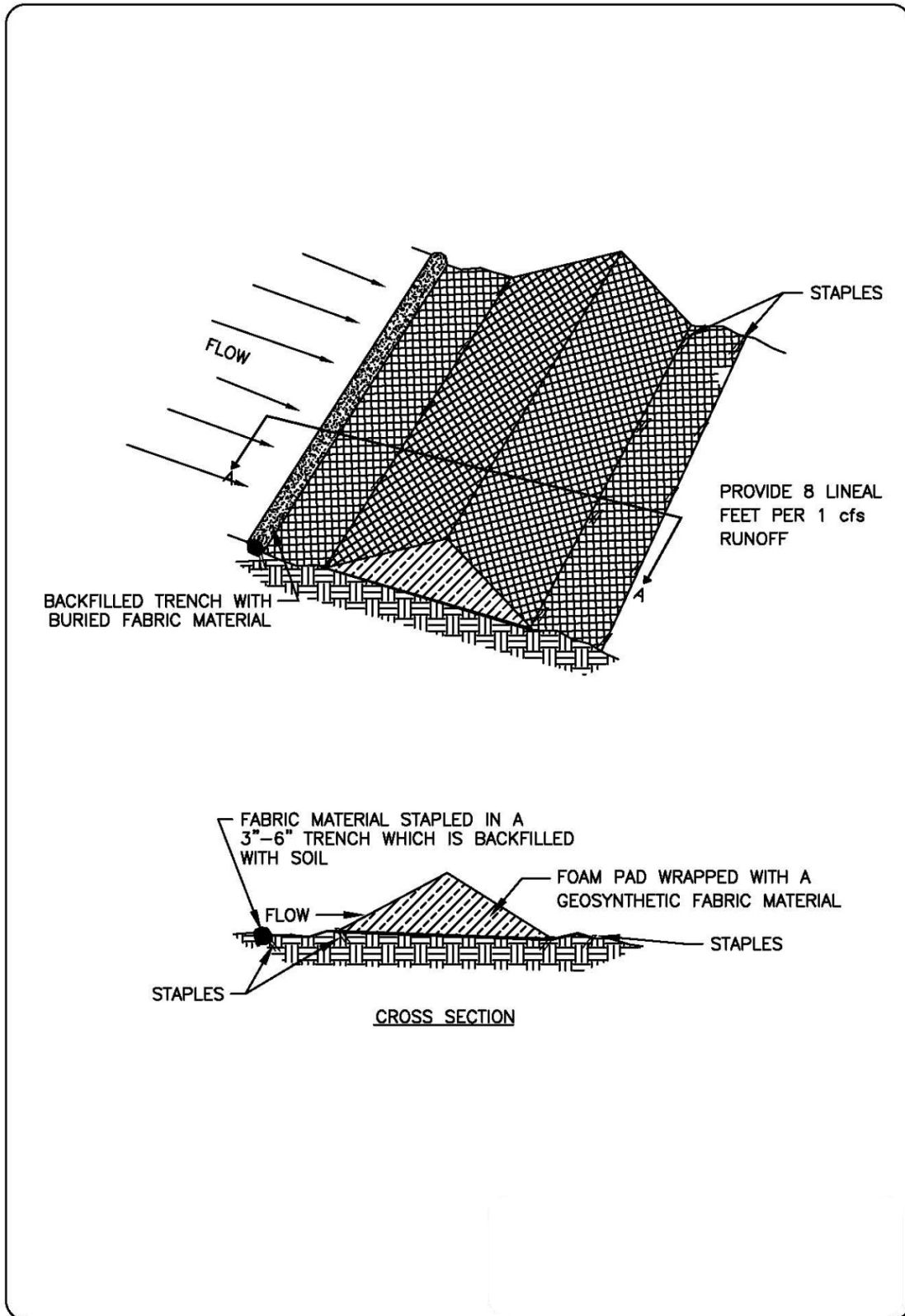
- May be used on soil or pavement with adhesive or staples.
- TSDs have been used to build temporary:
  - sediment ponds
  - diversion ditches
  - concrete wash out facilities
  - curbing
  - water bars
  - level spreaders
  - berms

#### **3.2.9.3 Design and Installation Specifications**

- Made of urethane foam sewn into a woven geosynthetic fabric.
- It is triangular, 10 inches to 14 inches high in the center, with a 20-inch to 28-inch base. A 2-foot apron extends beyond both sides of the triangle along its standard section of 7 feet. A sleeve at one end allows attachment of additional sections as needed.
- Install with ends curved up to prevent water from flowing around the ends.
- The fabric flaps and check dam units are attached to the ground with wire staples. Wire staples should be No. 11 gauge wire and should be 200 mm to 300 mm in length.
- When multiple units are installed, the sleeve of fabric at the end of the unit shall overlap the abutting unit and be stapled.
- Check dams should be located and installed as soon as construction will allow.
- Check dams should be placed perpendicular to the flow of water.
- When used as check dams, the leading edge must be secured with rocks, sandbags, or a small key slot and staples.

#### **3.2.9.4 Maintenance Standards**

- Monitor triangular silt dikes for performance and sediment accumulation during and after each runoff producing rainfall. Remove sediment when it reaches one half the height of the dam.
- Anticipate submergence and deposition above the triangular silt dam and erosion from high flows around the edges of the dam. Immediately repair any damage or undercutting of the dam.
- In the case of grass-lined ditches and swales, remove check dams and accumulated sediment when the grass has matured sufficiently to protect the ditch or swale, unless the slope of the swale is greater than 4 percent. Seed and mulch the area beneath the check dams immediately after dam removal.



**Figure 2 - 17. Sediment Barrier – Geosynthetic Dike**



### **3.2.10 BMP C209: Outlet Protection**

#### **3.2.10.1 Purpose**

Outlet protection prevents scour at conveyance outlets and minimizes the potential for downstream erosion by reducing the velocity of concentrated stormwater flows.

#### **3.2.10.2 Conditions of Use**

Outlet protection is required at the outlets of all ponds, pipes, ditches, or other conveyances, and where runoff is conveyed to a natural or manmade drainage feature such as a stream, wetland, lake, or ditch.

#### **3.2.10.3 Design and Installation Specifications**

- Protect the receiving channel at the outlet of a culvert from erosion by rock lining a minimum of 6 feet downstream and extending rock lining up the channel sides a minimum of 1-foot above the maximum tailwater elevation or 1-foot above the crown, whichever is higher. For large pipes (more than 18 inches in diameter), the outlet protection lining of the channel is lengthened to four times the diameter of the culvert.
- See Volume 3, Section 3.5 for permanent outlet protection.
- Organic or synthetic erosion blankets, with or without vegetation, may be, cheaper, and easier to install than rock. Materials can be chosen using manufacturer product specifications. ASTM test results are available for most products and the designer can choose the correct material for the expected flow.
- With low flows, vegetation (including sod) can be effective.
- Use the following guidelines for riprap outlet protection:
  - If the discharge velocity at the outlet is less than 5 feet per second (pipe slope less than 1 percent), use 2-inch to 8-inch riprap. Minimum thickness is 1-foot.
  - For 5 to 10 feet per second discharge velocity at the outlet (pipe slope less than 3 percent), use 24-inch to 4-foot riprap. Minimum thickness is 2 feet.
  - For outlets at the base of steep slope pipes (pipe slope greater than 10 percent), an engineered energy dissipater shall be used.
- Always use filter fabric or erosion control blankets under riprap to prevent scour and channel erosion.
- New pipe outfalls can provide an opportunity for low-cost fish habitat improvements. For example, an alcove of low-velocity water can be created by constructing the pipe outfall and associated energy dissipater back from the stream edge and digging a channel, over-widened to the upstream side, from the outfall. Overwintering juvenile and migrating adult salmonids may use the alcove as shelter during high flows. Bank stabilization, bioengineering, and habitat features may be required for disturbed areas. See Volume 3 for more information on outfall system design.

#### **3.2.10.4 Maintenance Standards**

- Inspect and repair as needed.
- Add rock as needed to maintain the intended function.
- Clean energy dissipater if sediment builds up.

### 3.2.11 BMP C220: Storm Drain Inlet Protection

#### 3.2.11.1 Purpose

To prevent coarse sediment from entering drainage systems prior to permanent stabilization of the disturbed area.

#### 3.2.11.2 Conditions of Use

- Where storm drain inlets are to be made operational before permanent stabilization of the disturbed drainage area.
- Provide protection for all storm drain inlets downslope and within 500 feet of a disturbed or construction area, unless the runoff that enters the catch basin will be conveyed to a sediment pond or trap. Inlet protection may be used anywhere to protect the drainage system. It is likely that the drainage system will still require cleaning.
- Table 2 - 11 lists several options for inlet protection. All of the methods for storm drain inlet protection are prone to plugging and require a high frequency of maintenance. Drainage areas should be limited to 1 acre or less. Emergency overflows may be required where stormwater ponding would cause a hazard. If an emergency overflow is provided, additional end-of-pipe treatment may be required.
- Only bag filter type catch basin filters (per Section 3.2.11.3) are allowed within the right of way.

**Table 2 - 11: Storm Drain Inlet Protection**

Type of Inlet Protection	Emergency Overflow	Applicable for Paved/Earthen Surfaces	Conditions of Use
Excavated drop inlet protection	Yes, temporary flooding will occur	Earthen	Applicable for heavy flows. Easy to maintain. Large area requirement: 30' x 30' per acre.
Block and gravel drop filter	Yes	Paved or earthen	Applicable for heavy concentrated flows. Will not pond.
Gravel and mesh filter	No	Paved	Applicable for heavy concentrated flows. Will pond. Can withstand traffic.
Catch basin filters	Yes	Paved or earthen	Frequent maintenance required.
Curb inlet protection with a wooden weir	Small capacity overflow	Paved	Used for sturdy, more compact installation.
Block and gravel curb inlet protection	Yes	Earthen	Sturdy, but limited filtration.
Culvert inlet sediment trap			18-month expected life.

#### 3.2.11.3 Design and Installation Specifications

##### **Excavated Drop Inlet Protection**

- An excavated impoundment around the storm drain. Sediment settles out of the stormwater prior to entering the storm drain.

- Provide depth of 1 to 2 feet, as measured from the crest of the inlet structure.
- Slope sides of excavation no steeper than 2H:1V.
- Minimum volume of excavation 35 cubic yards.
- Shape basin to fit site with longest dimension oriented toward the longest inflow area.
- Install provisions for draining to prevent standing water problems.
- Clear the area of all debris.
- Grade the approach to the inlet uniformly.
- Drill weep holes into the side of the inlet.
- Protect weep holes with screen wire and washed aggregate.
- Seal weep holes when removing structure and stabilizing area.
- It may be necessary to build a temporary dike to the down slope side of the structure to prevent bypass flow.

### ***Block and Gravel Filter***

- A barrier formed around the storm drain inlet with standard concrete blocks and gravel. See Figure 2 - 18.
- Provide a height 1 to 2 feet above inlet.
- Recess the first row 2 inches into the ground for stability.
- Support subsequent courses by placing a piece of 2x4 lumber through the block opening.
- Do not use mortar.
- Lay some blocks in the bottom row on their side for dewatering the pool.
- Place hardware cloth or comparable wire mesh with ½-inch openings over all block openings.
- Place gravel just below the top of blocks on slopes of 2H:1V or flatter.
- An alternative design is a gravel donut.
- Provide an inlet slope of 3H:1V.
- Provide an outlet slope of 2H:1V.
- Provide a 1-foot wide level stone area between the structure and the inlet.
- Use inlet slope stones 3 inches in diameter or larger.
- For outlet slope use gravel ½- to ¾-inch at a minimum thickness of 1-foot.

### ***Gravel and Wire Mesh Filter***

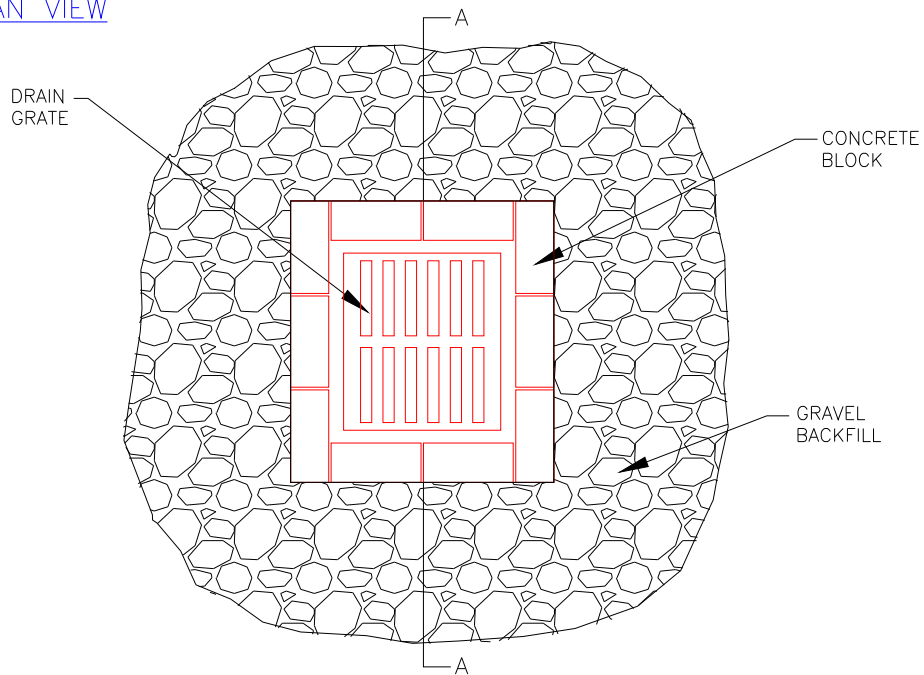
- A gravel barrier placed over the top of the inlet (see Figure 2 - 19). This structure does not provide an overflow.
- Use hardware cloth or comparable wire mesh with ½-inch openings.
- Use coarse aggregate.
- Place wire mesh over the drop inlet so that the wire extends a minimum of 1-foot beyond each side of the inlet structure.
- If more than one strip of mesh is necessary, overlap the strips.

- Place coarse aggregate over the wire mesh.
- The depth of the gravel should be at least 12 inches over the entire inlet opening and extend at least 18 inches on all sides.

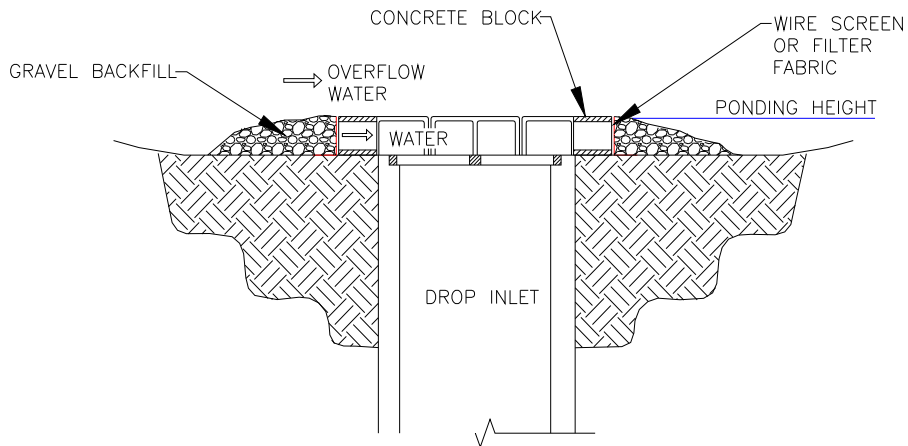
***Catchbasin Filters***

- Inserts (Figure 2 - 20) shall be designed by the manufacturer for use at construction sites. The limited sediment storage capacity increases the frequency of inspection and maintenance required, which may be daily for heavy sediment loads. The maintenance requirements can be reduced by combining a catchbasin filter with another type of inlet protection. This type of inlet protection provides flow bypass without overflow and therefore may be a better method for inlets located along active rights-of-way.
- Provide a minimum of 5 cubic feet of storage.
- Requires dewatering provisions.
- Provide a high-flow bypass that will not clog under normal use at a construction site.
- The catchbasin filter is inserted in the catchbasin just below the grating.
- Only bag filter type catch basin filters are allowed in the City right-of-way.

PLAN VIEW



SECTION A - A



NOTE:

1. DROP INLET SEDIMENT BARRIERS ARE TO BE USED FOR SMALL, NEARLY LEVEL DRAINAGE AREAS. (LESS THAN 5%)
2. EXCAVATE A BASIN OF SUFFICIENT SIZE ADJACENT TO THE INLET.
3. THE TOP OF THE STRUCTURE (POND HEIGHT) MUST BE WELL BELOW THE GROUND ELEVATION DOWNSLOPE TO PREVENT RUNOFF FROM BYPASSING THE INLET. A TEMPORARY DIKE MAY BE NECESSARY ON THE DOWNSLOPE SIDE OF THE STRUCTURE.

**Figure 2 - 18. Drop Inlet with Block and Gravel Filter**

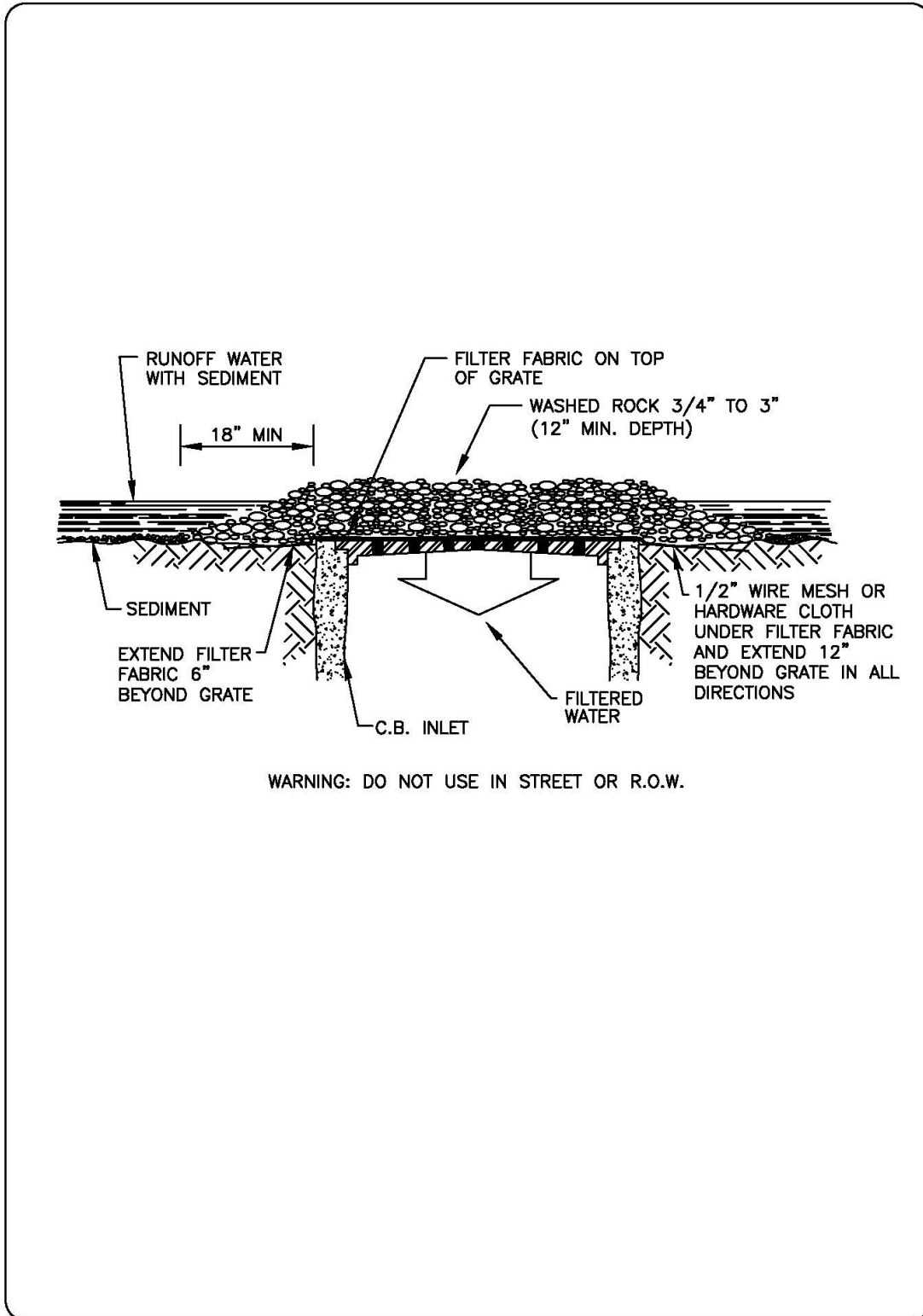
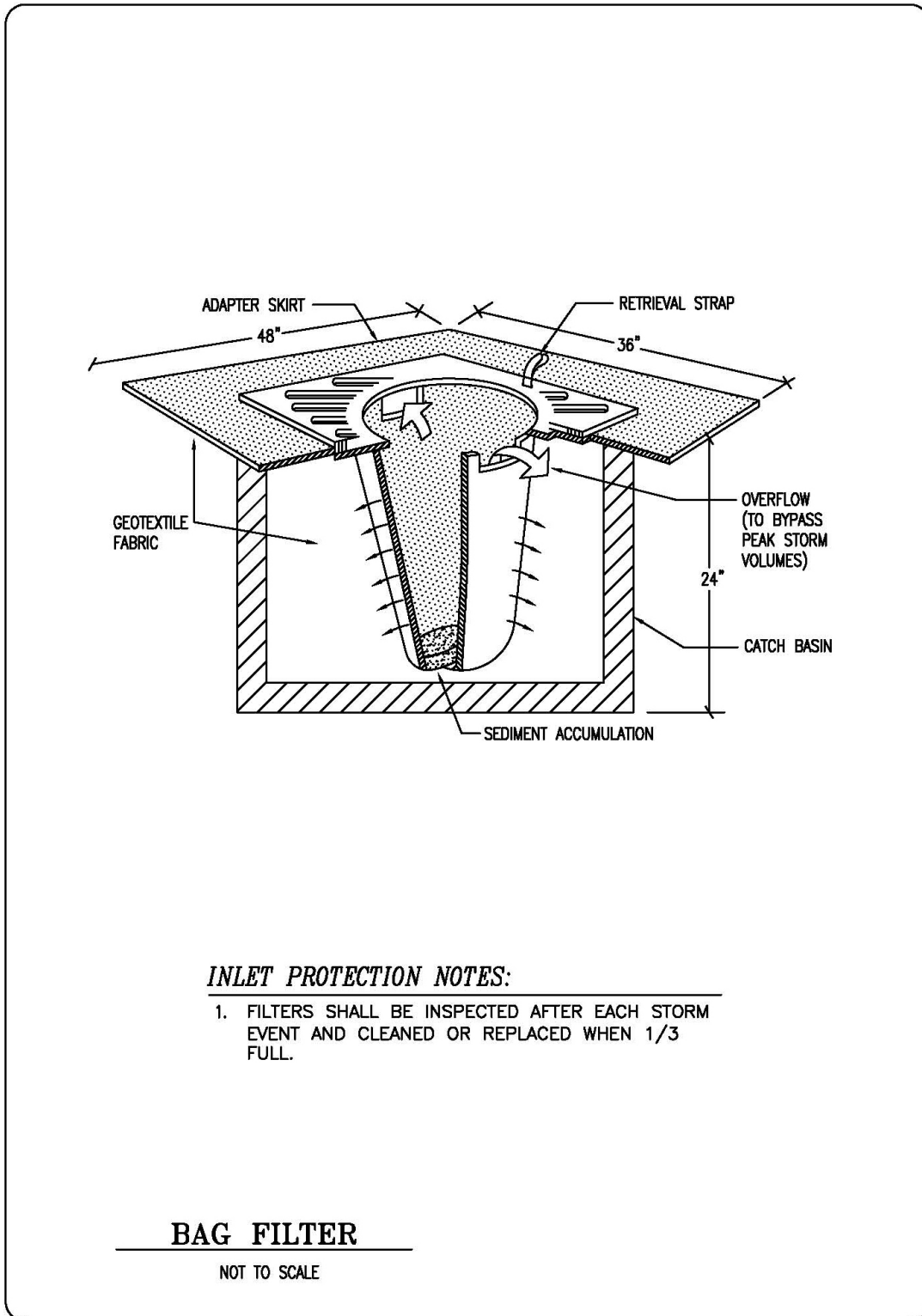


Figure 2 - 19. Gravel and Wire Mesh Filter



***INLET PROTECTION NOTES:***

1. FILTERS SHALL BE INSPECTED AFTER EACH STORM EVENT AND CLEANED OR REPLACED WHEN 1/3 FULL.

**Figure 2 - 20. Catchbasin Filter**

***Curb Inlet Protection with Wooden Weir***

Barrier formed around a curb inlet with a wooden frame and gravel.

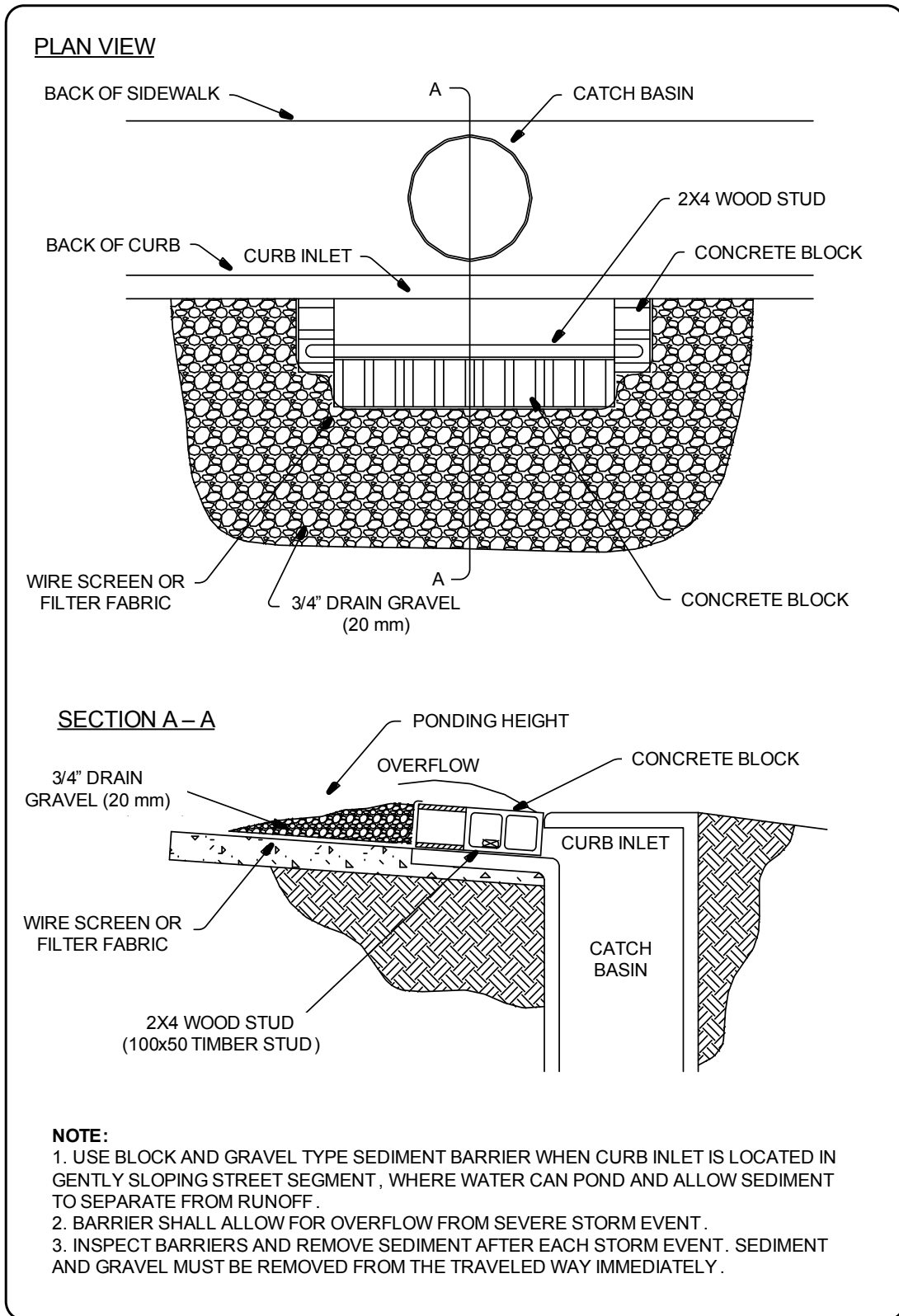
- Use wire mesh with ½-inch openings.
- Use extra strength filter cloth.
- Construct a frame.
- Attach the wire and filter fabric to the frame.
- Pile coarse washed aggregate against the wire and fabric.
- Place weight on frame anchors.

***Block and Gravel Curb Inlet Protection***

Barrier formed around an inlet with concrete blocks and gravel. See Figure 2 - 21.

- Use wire mesh with ½-inch openings.
- Place two concrete blocks on their sides abutting the curb at either side of the inlet opening. These are spacer blocks.
- Place a 2x4 stud through the outer holes of each spacer block to align the front blocks.
- Place blocks on their sides across the front of the inlet and abutting the spacer blocks.
- Place wire mesh over the outside vertical face.
- Pile coarse aggregate against the wire to the top of the barrier.





**Figure 2 - 21. Block and Gravel Curb Inlet Protection**

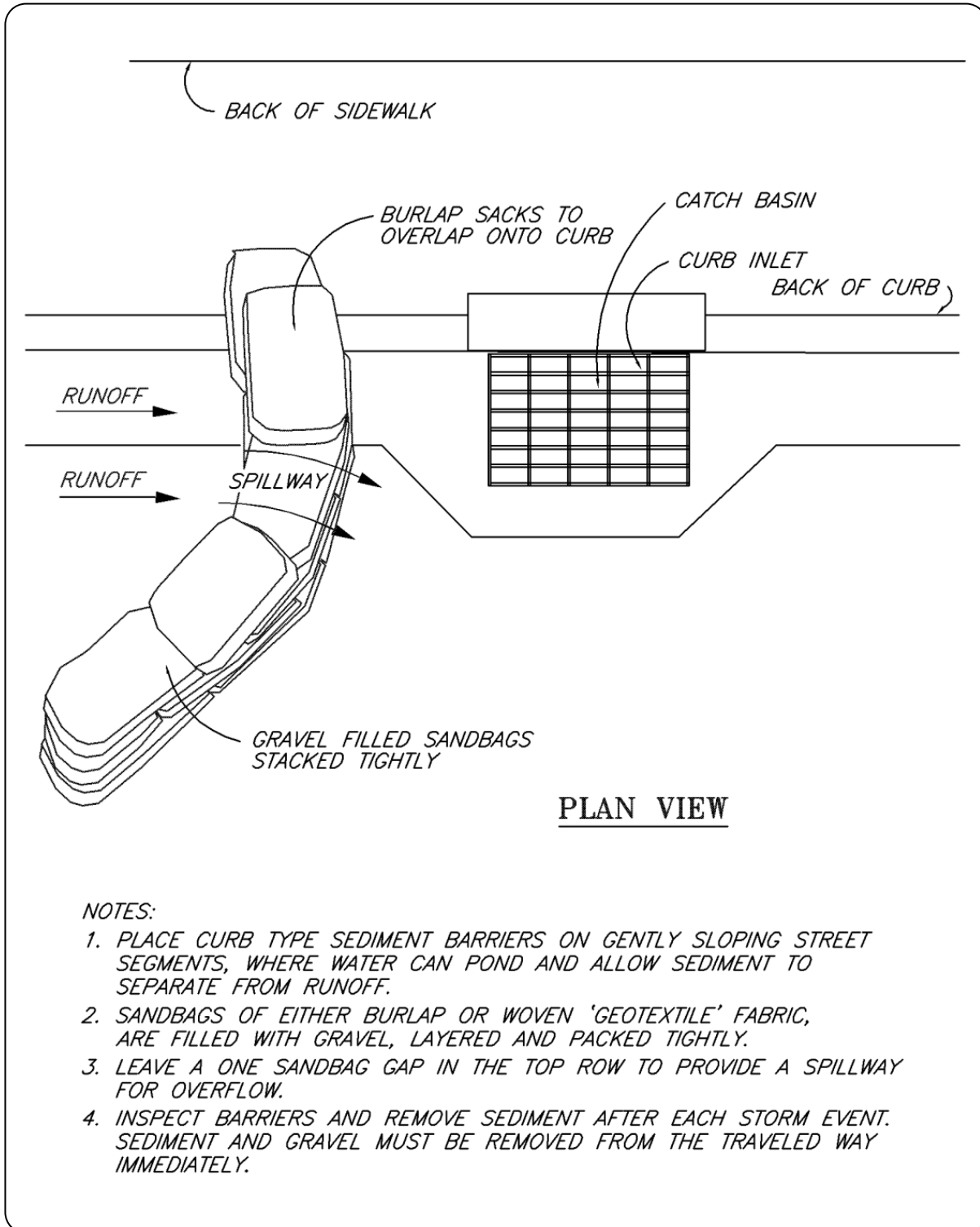
***Curb and Gutter Sediment Barrier***

Sandbag or rock berm (riprap and aggregate) 3 feet high and 3 feet wide in a horseshoe shape. See Figure 2 - 22.

- Construct a horseshoe shaped berm, faced with coarse aggregate if using riprap, 3 feet high and 3 feet wide, at least 2 feet from the inlet.
- Construct a horseshoe shaped sedimentation trap on the outside of the berm sized to sediment trap standards for protecting a culvert inlet.
- Sandbag must be gravel filled.

**3.2.11.4 Maintenance Standards**

- Inspect catch basin filters frequently, especially after storm events. If the insert becomes clogged, clean or replace it.
- For systems using stone filters: If the stone filter becomes clogged with sediment, the stones must be pulled away from the inlet and cleaned or replaced. Since cleaning of gravel at a construction site may be difficult, an alternative approach would be to use the clogged stone as fill and put fresh stone around the inlet.
- Do not wash sediment into storm drains while cleaning. Spread all excavated material evenly over the surrounding land area or stockpile and stabilize as appropriate.
- Do not allow accumulated sediment to enter the storm drain system.
- Inlet protection shall be removed when area is fully stabilized and erosion and sediment controls are no longer needed.



**Figure 2 - 22. Curb and Gutter Sediment Barrier**

### **3.2.12 BMP C231: Brush Barrier**

#### **3.2.12.1 Purpose**

The purpose of brush barriers is to reduce the transport of coarse sediment from a construction site by providing a temporary physical barrier to sediment and reducing the runoff velocities of overland flow.

#### **3.2.12.2 Conditions of Use**

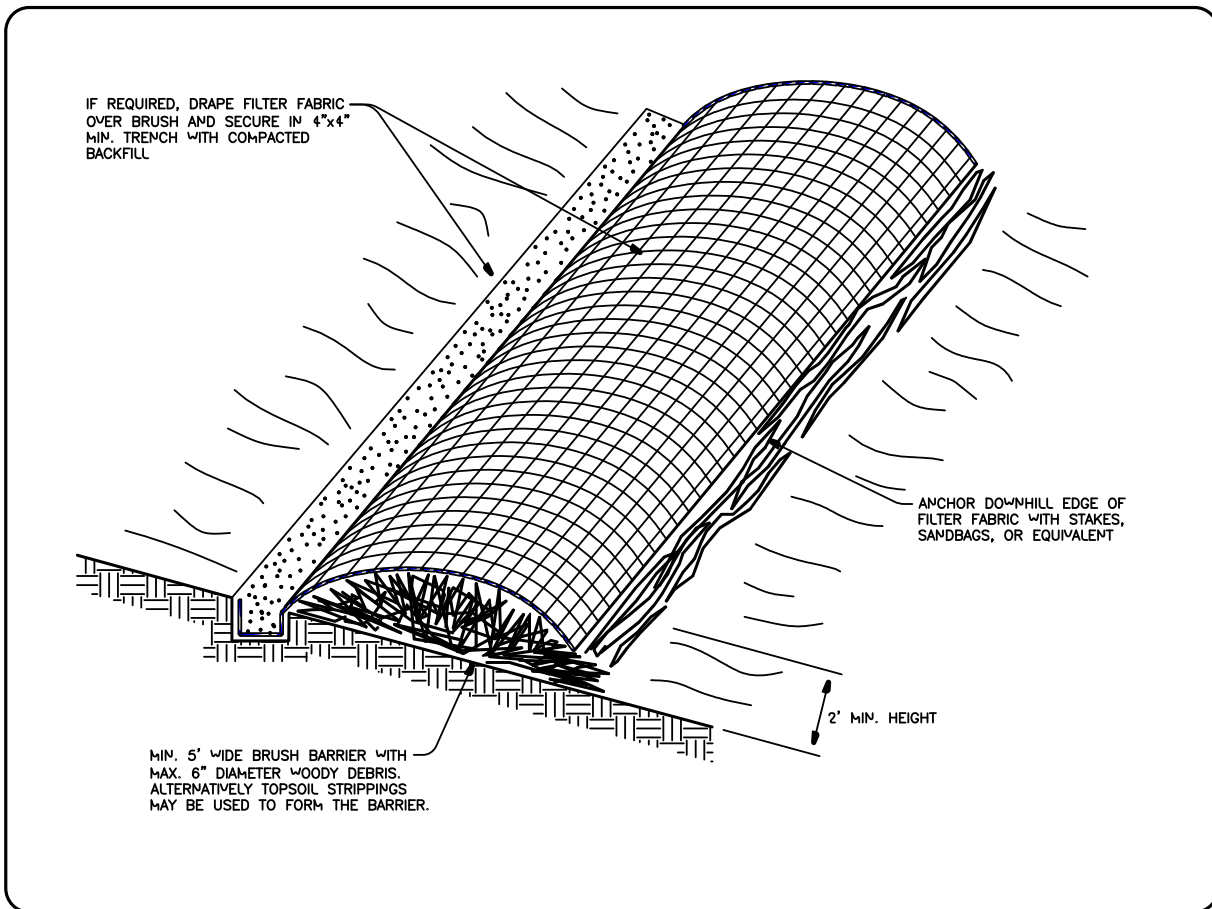
- Brush barriers may be used downslope of all disturbed areas of less than one-quarter acre.
- Brush barriers are not intended to treat concentrated flows, nor are they intended to treat substantial amounts of overland flow. Any concentrated flows must be conveyed through the drainage system to a sediment pond. The only circumstance in which overland flow can be treated solely by a barrier, rather than by a sediment pond, is when the area draining to the barrier is small.
- Only install brush barriers on contours.

#### **3.2.12.3 Design and Installation Specifications**

- Height 2 feet (minimum) to 5 feet (maximum).
- Width 5 feet at base (minimum) to 15 feet (maximum).
- Filter fabric (geotextile) may be anchored over the brush berm to enhance the filtration ability of the barrier. Ten-ounce burlap is an adequate alternative to filter fabric.
- Chipped site vegetation, compost, or wood-based mulch (hog fuel) as specified in BMP C121: Mulching can be used to construct brush barriers.
- A 100 percent biodegradable installation can be constructed using 10-ounce burlap held in place by wooden stakes. Figure 2 - 23 depicts a typical brush barrier.

#### **3.2.12.4 Maintenance Standards**

- Do not allow erosion or concentrated runoff under or around the barrier. If concentrated flows are bypassing the barrier, it must be expanded or augmented by toed-in filter fabric.
- Maintain the dimensions of the barrier.



**Figure 2 - 23. Brush Barrier**

### 3.2.13 BMP C232: Gravel Filter Berm

#### 3.2.13.1 Purpose

A gravel filter berm is constructed on rights-of-way or traffic areas within a construction site to retain sediment by using a filter berm of gravel or crushed rock.

#### 3.2.13.2 Conditions of Use

Where a temporary measure is needed to retain sediment from rights-of-way or in traffic areas on construction sites.

#### 3.2.13.3 Design and Installation Specifications

- Berm material shall be  $\frac{3}{4}$  to 3 inches in size, washed well-graded gravel or crushed rock, with less than 5 percent fines.
- Space berms:
  - Every 300 feet on slopes less than 5 percent
  - Every 200 feet on slopes between 5 percent and 10 percent

- Every 100 feet on slopes greater than 10 percent
- Berm dimensions:
  - 1 foot high with 3:1 side slopes
  - 8 linear feet per 1 cubic foot per second runoff based on the 10-year, 24-hour design storm event assuming a Type 1A rainfall distribution (3.0-inches)

#### **3.2.13.4 Maintenance Standards**

Regular inspection is required. Remove sediment and replace filter material as needed.

### **3.2.14 BMP C233: Silt Fence**

#### **3.2.14.1 Purpose**

Use of a silt fence reduces the transport of coarse sediment from a construction site by providing a temporary physical barrier to sediment and reducing the runoff velocities of overland flow. See Figure 2 - 24 for details on silt fence construction.

#### **3.2.14.2 Conditions of Use**

- Silt fence may be used downslope of all disturbed areas.
- Silt fence shall prevent soil carried by runoff water from going beneath, through, or over the top of the silt fence, but shall allow the water to pass through the fence.
- Silt fence is not intended to treat concentrated flows, nor is it intended to treat substantial amounts of overland flow. Convey any concentrated flows through the drainage system to a sediment pond. The only circumstance in which overland flow can be treated solely by a silt fence is when the area draining to the fence is one acre or less and flow rates are less than 0.5 cfs.
- Do not construct silt fences in streams or use them in V-shaped ditches. They are not an adequate method of silt control for anything deeper than sheet or overland flow.

#### **3.2.14.3 Design and Installation Specifications**

- Drainage area of 1 acre or less or in combination with appropriate sediment removal BMPs on larger sites.
- Maximum slope steepness (perpendicular to fence line) 1H:1V.
- Maximum sheet or overland flowpath length to the fence of 100 feet.
- No flows greater than 0.5 cubic feet per second.

- The geotextile used shall meet the following standards. All geotextile properties listed below are minimum average roll values (i.e., the test result for any sampled roll in a lot shall meet or exceed the values shown in Table 2 - 12).

**Table 2 - 12: Geotextile Standards**

Standard	Description
Polymeric Mesh AOS (ASTM D4751)	0.60 mm maximum for silt film wovens (#30 sieve). 0.30 mm maximum for all other geotextile types (#50 sieve). 0.15 mm minimum for all fabric types (#100 sieve).
Water Permittivity (ASTM D4491)	0.02 sec <sup>-1</sup> minimum
Grab Tensile Strength (ASTM D4632)	180 lbs. minimum for extra strength fabric. 100 lbs. minimum for standard strength fabric.
Grab Tensile Strength (ASTM D4632)	30% maximum
Ultraviolet Resistance (ASTM D4355)	70% minimum

- Support standard strength fabrics with wire mesh, chicken wire, 2-inch x 2-inch wire, safety fence, or jute mesh to increase the strength of the fabric. Silt fence materials are available that have synthetic mesh backing attached.
- Silt fence material shall contain ultraviolet ray inhibitors and stabilizers to provide a minimum of six months of expected usable construction life at a temperature range of 0° to 120° Fahrenheit.
- 100 percent biodegradable silt fence is available that is strong and long lasting.
- The following are standard design and installation methods. Refer to Figure 2 - 24 for standard silt fence details.
  - Install and maintain temporary silt fences at the locations shown in the plans. Install the silt fences in the areas of clearing, grading, or drainage prior to starting those activities. Do not consider a silt fence temporary if the silt fence must function beyond the life of the contract. The silt fence shall prevent soil carried by runoff water from going beneath, through, or over the top of the silt fence, but shall allow the water to pass through the fence.
  - The minimum height of the top of silt fence shall be 2 feet and the maximum height shall be 2½ feet above the original ground surface.
  - Sew the silt fence fabric together at the point of manufacture, or at an approved location as determined by the Engineer, to form lengths as required. Locate all sewn seams at a support post. Alternatively, two sections of silt fence can be overlapped, provided the Contractor can demonstrate, to the satisfaction of the Engineer, that the overlap is long enough and adjacent fence sections are close enough together to prevent silt laden water from escaping through the fence at the overlap.
  - Attach the silt fence fabric on the up-slope side of the posts and support system with staples, wire, or in accordance with the manufacturer's recommendations. Attach the silt fence fabric to the posts in a manner that reduces the potential for geotextile tearing at the staples, wire, or other connection device. Silt fence back-up support for the fabric in the form of a wire or plastic mesh is dependent on the properties of the fabric selected for use. If wire or plastic back-up mesh is used, fasten the mesh

- securely to the up-slope of the posts with the fabric being up-slope of the mesh back-up support.
- Bury the fabric at the bottom of the fence in a trench to a minimum depth of 4 inches below the ground surface. Backfill the trench and tamp the soil in place over the buried portion of the fabric, such that no flow can pass beneath the fence and scouring can not occur. When wire or polymeric back-up support mesh is used, the wire or polymeric mesh shall extend into the trench a minimum of 3 inches.
  - Drive fence posts in to a minimum depth of 18 inches. A minimum depth of 12 inches is allowed if topsoil or other soft subgrade soil is not present and a minimum depth of 18 inches cannot be reached. Increase fence post depths by 6 inches if the fence is located on slopes of 3H:1V or steeper and the slope is perpendicular to the fence. If required post depths cannot be obtained, adequately secure the posts by bracing or guying to prevent overturning of the fence due to sediment loading.
  - Locate the silt fences on contour as much as possible, except at the ends of the fence, where the fence shall be turned uphill such that the silt fence captures the runoff water and prevents water from flowing around the end of the fence.
  - If the fence must cross contours, with the exception of the ends of the fence, place gravel check dams perpendicular to the back of the fence to minimize concentrated flow and erosion along the back of the fence. The gravel check dams shall be approximately 1-foot deep at the back of the fence and be perpendicular to the fence at the same elevation until the top of the check dam intercepts the ground surface behind the fence. The gravel check dams shall consist of crushed surfacing base course, gravel backfill for walls, or shoulder ballast. Locate the gravel check dams every 10 feet along the fence where the fence must cross contours. The slope of the fence line where contours must be crossed shall not be steeper than 3H:1V.
  - Use wood, steel or equivalent posts. Wood posts shall have minimum dimensions of 2 inches by 2 inches, minimum by 3 feet minimum length, and shall be free of defects such as knots, splits, or gouges. Steel posts shall consist of either size No. 6 rebar or larger; ASTM A120 steel pipe with a minimum diameter of 1-inch; U, T, L, or C shape steel posts with a minimum weight of 1.35 pounds per foot; or other steel posts having equivalent strength and bending resistance to the post sizes listed. The spacing of the support posts shall be a maximum of 6 feet.
  - Fence back-up support, if used, shall consist of steel wire with a maximum mesh spacing of 2 inches, or a prefabricated polymeric mesh. The strength of the wire or polymeric mesh shall be equivalent to or greater than 180 pounds grab tensile strength. The polymeric mesh must be as resistant to ultraviolet radiation as the geotextile it supports.
  - Specification details for silt fence installation using the slicing method follow. Refer to Figure 2 - 25 for slicing method details.
    - The base of both end posts must be at least 2 to 4 inches above the top of the silt fence fabric on the middle posts for ditch checks to drain properly. Use a hand level or string level, if necessary, to mark base points before installation.
    - Install posts 3 to 4 feet apart in critical retention areas and a maximum of 6 feet apart in standard applications. If wire backing is used, post spacing may be increased to 8-foot maximum.



- Install posts 24 inches deep on the downstream side of the silt fence, and as close as possible to the fabric, enabling posts to support the fabric from upstream water pressure.
- Install posts with the nipples facing away from the silt fence fabric.
- Attach the fabric to each post with three ties, all spaced within the top 8 inches of the fabric. Attach each tie diagonally 45 degrees through the fabric, with each puncture at least 1 inch vertically apart. In addition, each tie should be positioned to hang on a post nipple when tightening to prevent sagging.
- Wrap approximately 6 inches of fabric around the end posts and secure with 3 ties.
- No more than 24 inches of a 36-inch fabric is allowed above ground level.
- The installation should be checked and corrected for any deviation before compaction. Use a flat-bladed shovel to tuck fabric deeper into the ground, if necessary.
- Compaction is vitally important for effective results. Compact the soil immediately next to the silt fence fabric with the front wheel of a tractor, skid steer, or roller exerting at least 60 pounds per square inch. Compact the upstream side first and then each side twice for a total of four trips.

**3.2.14.4 Maintenance Standards**

- Repair any damage immediately.
- If concentrated flows are evident uphill of the fence, intercept and convey them to a sediment pond.
- It is important to check the uphill side of the fence for signs of the fence clogging, acting as a barrier to flow, and then causing channelization of flows parallel to the fence. If this occurs, replace the fence or remove the trapped sediment.
- Remove sediment deposits when the deposit reaches approximately one-third the height of the silt fence, or install a second silt fence.
- If the filter fabric (geotextile) has deteriorated due to ultraviolet breakdown, replace it.

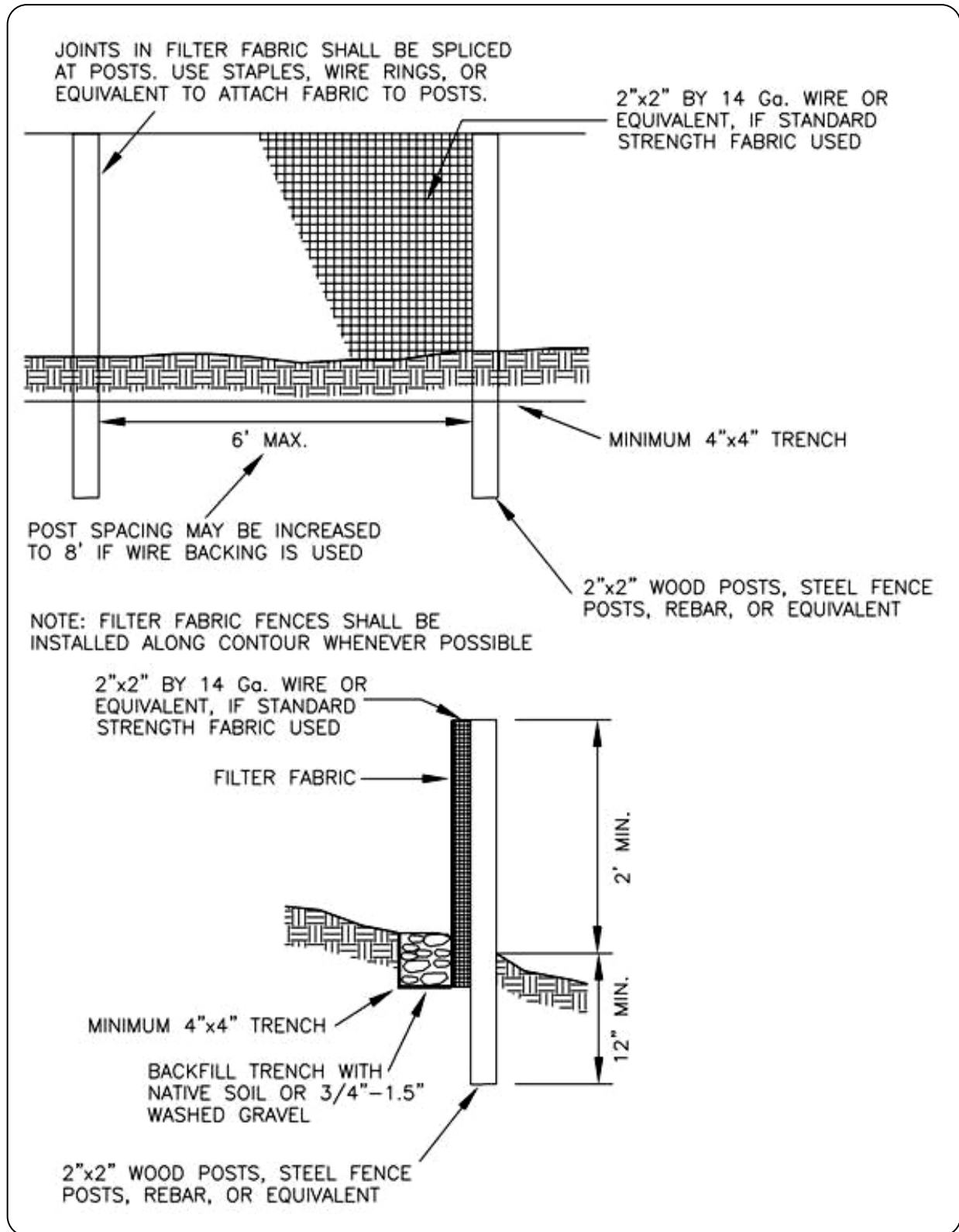
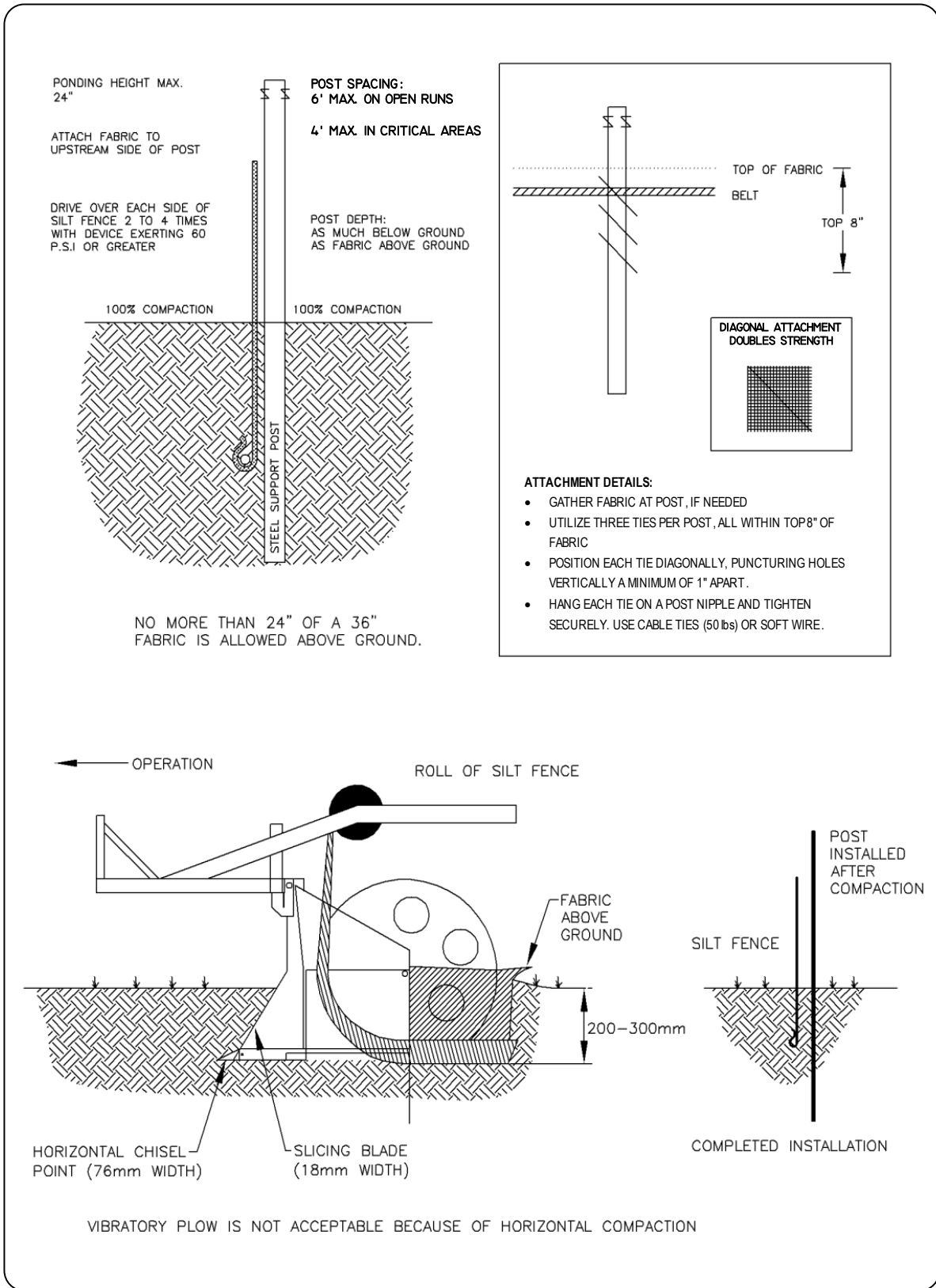


Figure 2 - 24. Silt Fence



**Figure 2 - 25. Silt Fence Installation by Slicing**

### 3.2.15 BMP C234: Vegetated Strip

#### 3.2.15.1 Purpose

Vegetated strips reduce the transport of coarse sediment from a construction site by providing a temporary physical barrier to sediment and reducing the runoff velocities of overland flow.

#### 3.2.15.2 Conditions of Use

Vegetated strips may be used downslope of all disturbed areas.

Vegetated strips are not intended to treat concentrated flows, nor are they intended to treat substantial amounts of overland flow. Convey any concentrated flows through the drainage system to a sediment pond. The only circumstance in which overland flow can be treated solely by a strip, rather than by a sediment pond, is when the criteria shown in Table 2 - 13 are met.

*Table 2 - 13: Vegetated Strips*

Average Slope	Slope Percent	Flowpath Length
1.5H:1V or less	67% or less	100 feet
2H:1V or less	50% or less	115 feet
4H:1V or less	25% or less	150 feet
6H:1V or less	16.7% or less	200 feet
10H:1V or less	10% or less	250 feet

#### 3.2.15.3 Design and Installation Specifications

- The vegetated strip shall consist of a minimum of a 25-foot wide continuous strip of dense vegetation with permeable topsoil. Grass-covered, landscaped areas are generally not adequate because the volume of sediment overwhelms the grass. Ideally, vegetated strips shall consist of undisturbed native growth with a well-developed soil that allows for infiltration of runoff.
- The slope within the strip shall not exceed 4H:1V.
- Delineate the uphill boundary of the vegetated strip with clearing limits.

#### 3.2.15.4 Maintenance Standards

- Seed any areas damaged by erosion or construction activity immediately and protect with mulch.
- If more than 5 feet of the original vegetated strip width has had vegetation removed or is being eroded, install sod.
- If there are indications that concentrated flows are traveling across the vegetated strip, surface water controls must be installed to reduce the flows entering the vegetated strip, or install additional perimeter protection.

### 3.2.16 BMP C235: Wattles

#### 3.2.16.1 Purpose

Wattles are temporary erosion and sediment control barriers consisting of straw, compost or other material that is wrapped in biodegradable tubular plastic or similar encasing material. They

reduce the velocity and can spread the flow of rill and sheet runoff, and can capture and retain sediment. Wattles are typically 8 to 10 inches in diameter and 25 to 30 feet in length. The wattles are placed in shallow trenches and staked along the contour of disturbed or newly constructed slopes. See Figure 2 - 26 for typical construction details.

### **3.2.16.2 Conditions of Use**

- Use wattles
  - In disturbed areas that require immediate erosion protection.
  - On exposed soils during the period of short construction delays.
  - On slopes requiring stabilization until permanent vegetation can be established.
- Wattles are typically effective for one to two seasons.
- If conditions are appropriate, wattles can be staked to the ground using live cuttings for added revegetation.

### **3.2.16.3 Design Criteria**

- It is critical that wattles are installed perpendicular to the flow direction and parallel to the slope contour.
- Dig narrow trenches across the slope on contour to a depth of 3 to 5 inches on clay soils and soils with gradual slopes. On loose soils, steep slopes, and areas with high rainfall, dig the trenches to a depth of 5 to 7 inches, or 1/2 to 2/3 of the thickness of the wattle.
- Start building trenches and installing wattles from the base of the slope and work up. Excavated material should be spread evenly along the uphill slope and compacted using hand tamping or other methods.
- Construct trenches at contour intervals of 3 to 30 feet apart depending on the steepness of the slope, soil type, and rainfall. The steeper the slope, the closer together the trenches shall be.
- Install the wattles snugly into the trenches and abut tightly end to end. Do not overlap the ends. Rilling can occur beneath wattles if not properly entrenched, and water can pass between wattles if not tightly abutted.
- Install stakes at each end of the wattle, and at 4-foot centers along entire length of wattle.
- If required, install pilot holes for the stakes using a straight bar to drive holes through the wattle and into the soil.
- At a minimum, wooden stakes should be approximately 3/4 x 3/4 x 24 inches, minimum. Live cuttings or 3/8-inch rebar can also be used for stakes.
- Stakes should be driven through the middle of the wattle, leaving 2 to 3 inches of the stake protruding above the wattle.
- Compost wattles shall comply with BMP C125: Compost.

### **3.2.16.4 Maintenance Standards**

- Wattles may require maintenance to ensure they are in contact with soil and thoroughly entrenched, especially after significant rainfall on steep sandy soils.
- Inspect the slope after significant storms and repair any areas where wattles are not tightly abutted or water has scoured beneath the wattles.

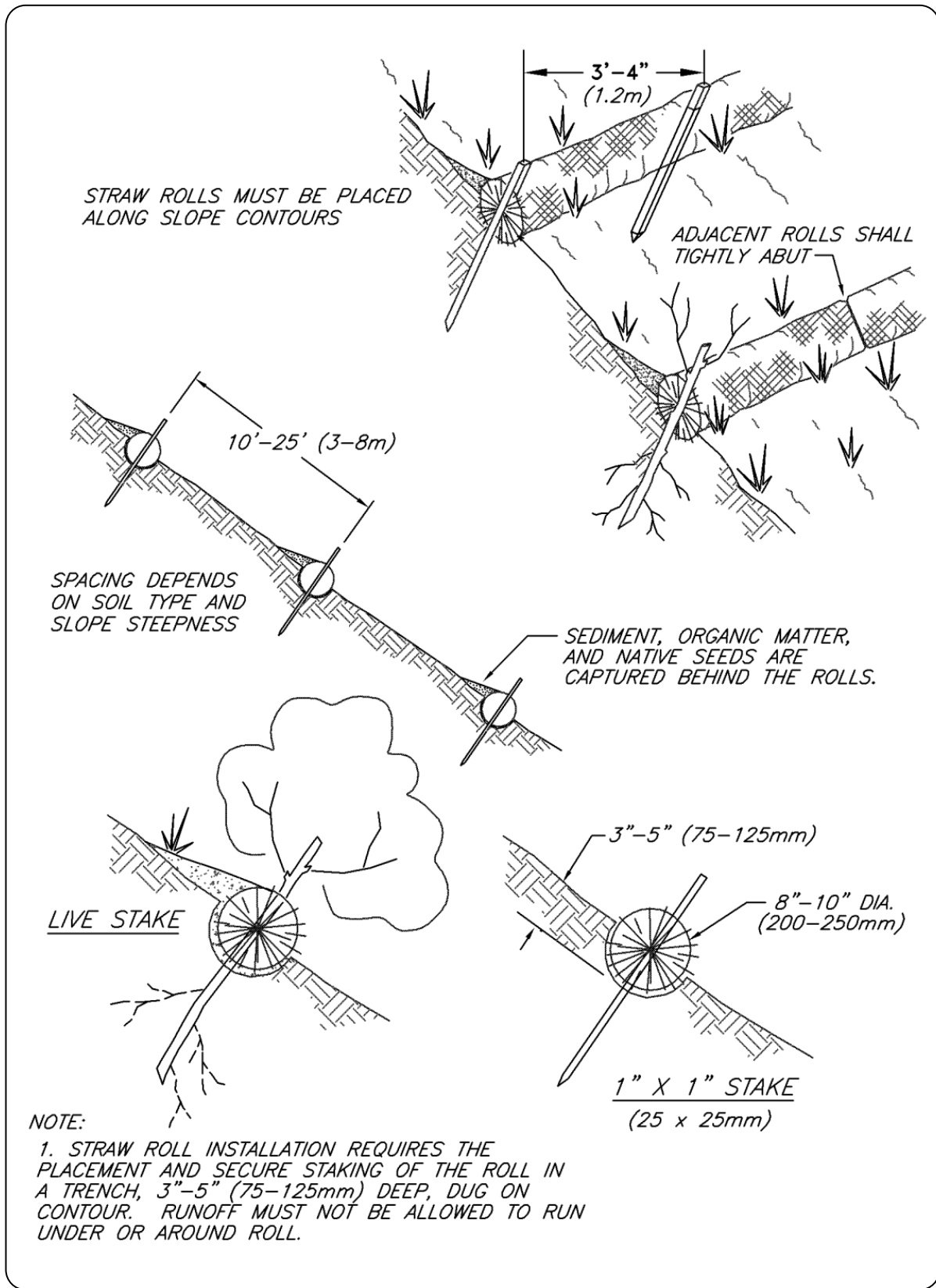


Figure 2 - 26. Straw Wattles

### **3.2.17 BMP C236: Vegetative Filtration**

#### **3.2.17.1 Purpose**

Vegetative Filtration may be used in conjunction with BMP C241 Temporary Sediment Ponds, BMP C206 Level Spreader and a pumping system with surface intake to improve turbidity levels of stormwater discharges by filtering through existing vegetation where undisturbed forest floor duff layer or established lawn with thatch layer are present. Vegetative Filtration can also be used to infiltrate dewatering waste from foundations, vaults, and trenches as long as runoff does not occur.

#### **3.2.17.2 Conditions of Use**

- For every five acre of disturbed soil use one acre of grass field, farm pasture, or wooded area. Reduce or increase this area depending on project size, groundwater table height, and other site conditions.
- Wetlands shall not be used for filtration.
- Do not use this BMP in areas with a high groundwater table, or in areas that will have a high seasonal groundwater table during the use of this BMP.
- This BMP may be less effective on soils that prevent the infiltration of the water, such as hard till.
- Using other effective source control measures throughout a construction site will prevent the generation of additional highly turbid water and may reduce the time period or area need for this BMP.
- Stop distributing water into the vegetated area if standing water or erosion results.

#### **3.2.17.3 Design Criteria**

- Find land adjacent to the project that has a vegetated field, preferably a farm field, or wooded area.
- If the project site does not contain enough vegetated field area consider obtaining permission from adjacent landowners (especially for farm fields).
- Install a pump and downstream distribution manifold depending on the project size. Generally, the main distribution line should reach 100 to 200-feet long (many large projects, or projects on tight soil, will require systems that reach several thousand feet long with numerous branch lines off of the main distribution line).
- The manifold should have several valves, allowing for control over the distribution area in the field.
- Install several branches of 4" schedule 20, swaged-fit common septic tight-lined sewer line, or 6" fire hose, which can convey the turbid water out to various sections of the field. See Figure 2 - 27.
- Determine the branch length based on the field area geography and number of branches. Typically, branches stretch from 200-feet to several thousand feet. Always, lay branches on contour with the slope.
- On uneven ground, sprinklers perform well. Space sprinkler heads so that spray patterns do not overlap.
- On relatively even surfaces, a level spreader using 4-inch perforated pipe may be used as an alternative option to the sprinkler head setup. Install drain pipe at the highest point on the field and at various lower elevations to ensure full coverage of the filtration area.



Pipe should be placed with the holes up to allow for a gentle weeping of stormwater evenly out all holes. Leveling the pipe by staking and using sandbags may be required.

- To prevent the over saturation of the field area, rotate the use of branches or spray heads. Do this as needed based on monitoring the spray field.
- Monitor the spray field on a daily basis to ensure that over saturation of any portion of the field doesn't occur at any time. The presence of standing puddles of water or creation of concentrated flows visually signify that over saturation of the field has occurred.
- Since the operator is handling contaminated water, physically monitor the vegetated spray field all the way down to the nearest surface water, or furthest spray area, to ensure that the water has not caused overland or concentrated flows, and has not created erosion around the spray nozzle.
- Monitoring usually needs to take place 3-5 times per day to ensure sheet-flow into state waters. Do not exceed water quality standards for turbidity.
- Ecology strongly recommends that a separate inspection log be developed, maintained and kept with the existing site logbook to aid the operator conducting inspections. This separate "Field Filtration Logbook" can also aid the facility in demonstrating compliance with permit conditions.

**3.2.17.4 Maintenance Standards**

- Inspect the spray nozzles daily, at a minimum, for leaks and plugging from sediment particles.
- If erosion, concentrated flows, or over saturation of the field occurs, rotate the use of branches or spray heads or move the branches to a new field location.
- Check all branches and the manifold for unintended leaks.

**Table 2 - 14: Flowpath Guidelines for Vegetative Filtration**

Average Slope	Average Area % Slope	Estimated Flowpath Length (ft)
1.5H:1V	67%	250 feet
2H:1V	50%	200 feet
4H:1V	25%	150 feet
6H:1V	16.7%	115 feet
10H:1V	10%	100 feet



*Figure 2 - 27. Manifold and branches in a wooded, vegetated spray field*

### **3.2.18 BMP C240: Sediment Trap**

#### **3.2.18.1 Purpose**

A sediment trap is a small temporary ponding area with a gravel outlet used to collect and store sediment from sites cleared and/or graded during construction. Install sediment traps, along with other perimeter controls, before any land disturbance takes place in the drainage area.

#### **3.2.18.2 Conditions of Use**

- Prior to leaving a construction site, stormwater runoff must pass through a sediment pond or trap or other appropriate sediment removal best management practice. Non-engineered sediment traps may be used onsite prior to an engineered sediment trap or sediment pond to provide additional sediment removal capacity.
- Sediment traps are intended for use on sites where the tributary drainage area is less than 3 acres, with no unusual drainage features, and a projected build-out time of six months or less. The sediment trap is a temporary measure (with a design life of approximately 6 months) and shall be maintained until the site area is permanently protected against erosion by the installation of vegetation and/or structures.
- Sediment traps and ponds are only effective in removing sediment down to about the medium silt size fraction. Runoff with sediment of finer grades (fine silt and clay) will pass through untreated, emphasizing the need to control erosion to the maximum extent first.
- Whenever possible, discharge sediment-laden water into onsite, relatively level, vegetated areas (see BMP C234 – Vegetated Strip). Do not use vegetated wetlands for this purpose. All projects that are constructing permanent detention facilities for runoff quantity control should use the rough-graded or final-graded permanent facilities for traps and ponds. This includes combined facilities and infiltration facilities. When permanent

facilities are used as temporary sedimentation facilities, the surface area requirement of a sediment trap or pond must be met. If the surface area requirements are larger than the surface area of the permanent facility, then the trap or pond shall be enlarged to comply with the surface area requirement. The permanent pond shall also be divided into two cells as required for sediment ponds.

- Use of infiltration facilities for sedimentation basins during construction tends to clog the soils and reduce their capacity to infiltrate. If infiltration facilities are to be used, the sides and bottom of the facility must only be rough excavated to a minimum of 2 feet above final grade. Final grading of the infiltration facility shall occur only when all contributing drainage areas are fully stabilized. The infiltration pretreatment facility should be fully constructed and used with the sedimentation basin to help prevent clogging.
- Either a permanent control structure or the temporary control structure described in BMP C241 - Temporary Sediment Pond can be used. If a permanent control structure is used, it may be advisable to partially restrict the lower orifice with gravel to increase residence time while still allowing dewatering of the pond. A shut-off valve may be added to the control structure to allow complete retention of stormwater in emergency situations. In this case, add an emergency overflow weir.
- A skimmer may be used for the sediment trap outlet if approved by the City.

### 3.2.18.3 Design and Installation Specifications

See Figure 2 - 28 and Figure 2 - 29 for details.

If permanent runoff control facilities are part of the project, they should be used for sediment retention.

- To determine the sediment trap geometry, first calculate the design surface area (SA) of the trap, measured at the invert of the weir. Use the following equation:

$$SA = FS(Q_2/V_s)$$

Where:

SA = Design surface area, in square feet, of the sediment trap measured at the invert of the weir.

$Q_2$  = Design inflow, in cubic feet per second, based on the peak discharge from the developed 2-year runoff event from the contributing drainage area as computed in the hydrologic analysis. The 10-year peak flow shall be used if the project size, expected timing and duration of construction, or downstream conditions warrant a higher level of protection. If no hydrologic analysis is required, the Rational Method may be used.

Alternatively,  $Q_2$  = Design inflow (cfs) based on the 2-year return period flowrate, predicted by WWHM for the developed (unmitigated site). Use the 10-year return period flowrate if the project size, expected timing and duration of construction, or downstream conditions warrant a higher level of protection.  $Q_{10}$  is the 10-year return period flowrate, predicted by WWHM.

$V_s$  = The settling velocity of the soil particle of interest. The 0.02 millimeter (medium silt) particle with an assumed density of 2.65 grams per cubic centimeter has been

selected as the particle of interest and has a settling velocity ( $V_s$ ) of 0.00096 feet per second.

$FS =$  A safety factor of 2 to account for non-ideal settling.

Therefore, the equation for computing surface area becomes:

$$SA = 2 \times Q_2 / 0.00096 \text{ or}$$

$$= 2080 (Q_2)$$

**NOTE:** Even if permanent facilities are used, they must still have a surface area that is at least as large as that derived from the above formula. If they do not, the pond must be enlarged.

- Smaller sites may use the minimum pond sizes in Table 2 - 15 instead of providing calculations.

**Table 2 - 15: Sediment Trap Sizing**

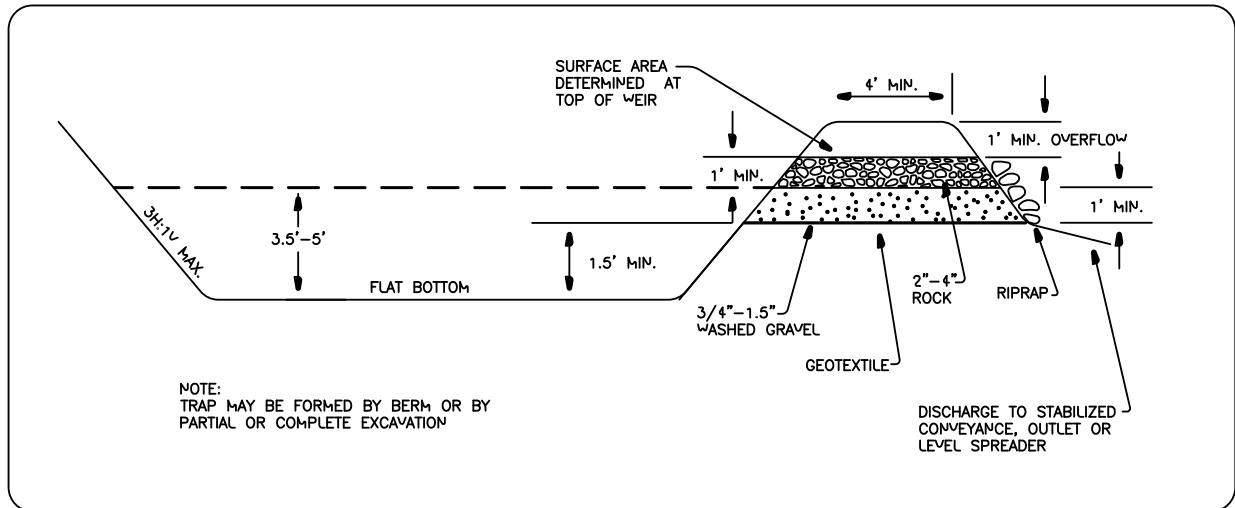
Contributing Area (acres)	Required Surface Area of Pond (sq. ft.)
1/8 acre or less	130
1/4 acre or less	260
1/2 acre or less	520
3/4 acre or less	780
1 acre or less	1040

- To aid in determining sediment depth, all sediment traps shall have a staff gauge with a prominent mark 1-foot above the bottom of the trap.
- Sediment traps may not be feasible on utility projects due to the limited work space or short-term nature of the work. Portable tanks may be used in place of sediment traps for utility projects.
- The basic geometry of the pond can now be determined using the following design criteria:
  - Required surface area SA (from the equation above) at top of riser.
  - Minimum 3.5-foot depth from top of riser to bottom of pond.
  - Maximum 3H:1V interior side slopes and maximum 2H:1V exterior slopes. The interior slopes can be increased to a maximum of 2H:1V if fencing is provided at or above the maximum water surface.
  - One foot of freeboard between the top of the riser and the crest of the emergency spillway.
  - Flat bottom.
  - Minimum 1-foot deep spillway.

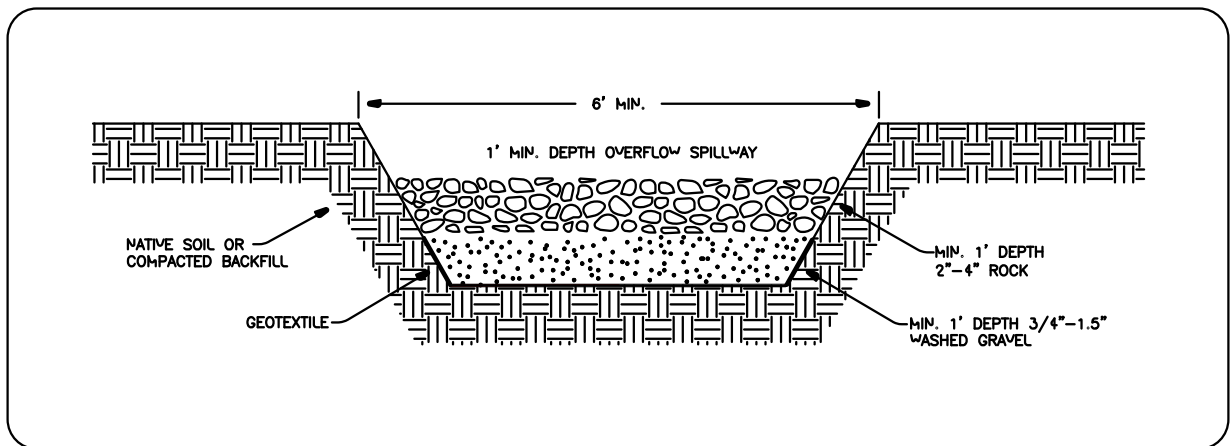
- Length-to-width ratio between 3:1 and 6:1.

**3.2.18.4 Maintenance Standards**

- Remove sediment from the trap when it reaches 1-foot in depth.
- Repair any damage to the pond embankments or slopes.



**Figure 2 - 28. Cross-Section of a Sediment Trap**



**Figure 2 - 29. Sediment Trap Outlet**

**3.2.19 BMP C241: Temporary Sediment Pond**

**3.2.19.1 Purpose**

Sediment ponds remove sediment from runoff originating from disturbed areas of the site. Sediment ponds are typically designed to remove sediment no smaller than medium silt (0.02 mm). Consequently, they usually reduce turbidity only slightly.

### **3.2.19.2 Conditions of Use**

- Prior to leaving a construction site, stormwater runoff must pass through a sediment pond or other appropriate sediment removal best management practice.
- Use a sediment pond where the contributing drainage area is 3 acres or more. Ponds must be used in conjunction with erosion control practices to reduce the amount of sediment flowing into the basin.

### **3.2.19.3 Design and Installation Specifications**

- Only install sediment basins on sites where failure of the structure would not result in loss of life, damage to homes or buildings, or interruption of use or service of public roads or utilities. Also, sediment traps and ponds are attractive to children and can be very dangerous. Compliance with local ordinances regarding health and safety must be addressed. If fencing of the pond is required, show the type of fence and its location on the ESC plan.
- Structures having a maximum storage capacity at the top of the dam of 10 acre-feet (435,600 cubic feet) or more are subject to the Washington Dam Safety Regulations (Chapter 173-175 WAC).
- See Figure 2 - 30, Figure 2 - 31 and Figure 2 - 32 for details.
- If permanent detention facilities are part of the project, they may be used for sediment retention. The surface area requirements of the sediment basin must be met. This may require enlarging the permanent basin to comply with the surface area requirements. If a permanent control structure is used, it may be advisable to partially restrict the lower orifice with gravel to increase residence time while still allowing dewatering of the basin.
- Use of infiltration facilities for sedimentation basins during construction tends to clog the soils and reduce their capacity to infiltrate. If infiltration facilities are to be used, the sides and bottom of the facility must only be rough excavated to a minimum of 2 feet above final grade. Final grading of the infiltration facility shall occur only when all contributing drainage areas are fully stabilized. The infiltration pretreatment facility should be fully constructed and used with the sedimentation basin to help prevent clogging.

### ***Determining Pond Geometry***

- Determine the required surface area at the top of the riser pipe with the equation:

$$SA = 2 \times Q_2 / 0.00096 \text{ or}$$

$$SA = 2080 (Q_2)$$

Where:

SA = Design surface area, in square feet, of the sediment trap measured at the invert of the weir.

$Q_2$  = Design inflow, in cubic feet per second, based on the peak discharge from the developed 2-year runoff event from the contributing drainage area as computed in the hydrologic analysis. The 10-year peak flow shall be used if the project size, expected timing and duration of construction, or downstream conditions warrant a higher level of protection. If no hydrologic analysis is required, the Rational Method may be used.

Alternatively,  $Q_2$  = Design inflow (cfs) based on the 2-year return period flowrate, predicted by WWHM for the developed (unmitigated site). Use the 10-year return period flowrate if the project size, expected timing and duration of construction, or downstream conditions warrant a higher level of protection.  $Q_{10}$  is the 10-year return period flowrate, predicted by WWHM.

- See BMP C240 for more information on the derivation of the surface area calculation.
- The basic geometry of the pond can now be determined using the following design criteria:
  - Required surface area SA (from the equation above) at top of riser.
  - Minimum 3.5-foot depth from top of riser to bottom of pond.
  - Maximum 3H:1V interior side slopes and maximum 2H:1V exterior slopes. The interior slopes can be increased to a maximum of 2H:1V if fencing is provided at or above the maximum water surface.
  - One foot of freeboard between the top of the riser and the crest of the emergency spillway.
  - Flat bottom.
  - Minimum 1-foot deep spillway.
  - Length-to-width ratio between 3:1 and 6:1.

### **Sizing of Discharge Mechanisms**

The outlet for the basin consists of a combination of principal and emergency spillways. These outlets must pass the peak runoff expected from the contributing drainage area for a 100-year storm. If, due to site conditions and basin geometry, a separate emergency spillway is not feasible, the principal spillway must pass the entire peak runoff expected from the 100-year storm. However, an attempt to provide a separate emergency spillway should always be made. The runoff calculations shall be based on the site conditions during construction. The flow through the dewatering orifice cannot be utilized when calculating the 100-year storm elevation because of its potential to become clogged; therefore, available spillway storage must begin at the principal spillway riser crest.

The principal spillway designed by the procedures contained in this standard will result in some reduction in the peak rate of runoff. However, the riser outlet design will not adequately control the basin discharge to the predevelopment discharge limitations as stated in Minimum Requirement #7: Flow Control. However, if the basin for a permanent stormwater detention pond is used for a temporary sedimentation basin, the control structure for the permanent pond can be used to maintain predevelopment discharge limitations. The size of the basin, the expected life of the construction project, the anticipated downstream effects, and the anticipated weather conditions during construction should be considered to determine the need of additional discharge control. See Figure 2 - 33 for riser inflow curves.

**Principal Spillway:** Determine the required diameter for the principal spillway (riser pipe). The diameter shall be the minimum necessary to pass the pre-developed 10-year peak flow ( $Q_{10}$ ). If using WWHM,  $Q_{10}$  is the 10-year return period flowrate. Use Figure 2 - 33 to determine this diameter ( $h = 1$ -foot).

**NOTE:** A permanent control structure may be used instead of a temporary riser.

**Emergency Overflow Spillway:** Determine the required size and design of the emergency overflow spillway for the developed 100-year peak flow using the method contained in Volume 3. If using WWHM,  $Q_{100}$  is the 100-year return period flowrate.

**Dewatering Orifice:** Determine the size of the dewatering orifice(s) (minimum 1-inch diameter) using a modified version of the discharge equation for a vertical orifice and a basic equation for the area of a circular orifice. Determine the required area of the orifice with the following equation:

$$A_o = \frac{A_s (2h)^{0.5}}{0.6 \times 3600 T g^{0.5}}$$

Where:

- $A_o$ = orifice area (square feet)
- $A_s$ = pond surface area (square feet)
- $h$ = head of water above orifice (height of riser in feet)
- $T$ = dewatering time (24 hours)
- $g$ = acceleration of gravity (32.2 feet per second squared)
- $D$ = orifice diameter (inches)

Convert the required surface area to the required diameter  $D$  of the orifice:



$$D = 24 \times \sqrt{\frac{A_o}{\pi}} = 13.54 \times \sqrt{A_o}$$

The vertical, perforated tubing connected to the dewatering orifice must be at least 2 inches larger in diameter than the orifice to improve flow characteristics. The size and number of perforations in the tubing shall be large enough so the tubing does not restrict flow. The orifice shall control the flow rate.

### ***Additional Design Specifications***

The **pond shall be divided** into two roughly equal volume cells by a permeable divider that will reduce turbulence while allowing movement of water between cells. The divider shall be at least one-half the height of the riser and a minimum of one foot below the top of the riser. Wire-backed, 2- to 3-foot high, extra strength filter fabric supported by treated 4"x4"s can be used as a divider. If the pond is more than 6 feet deep, a different mechanism must be proposed. A riprap embankment is one acceptable method of separation for deeper ponds. Other designs that satisfy the intent of this provision are allowed as long as the divider is permeable, structurally sound, and designed to prevent erosion under or around the barrier.

To aid in determining sediment depth, prominently mark **one-foot intervals** on the riser.

If an **embankment height** of more than 6 feet is proposed, the pond must comply with the criteria contained in Volume 3 regarding dam safety for detention BMPs.

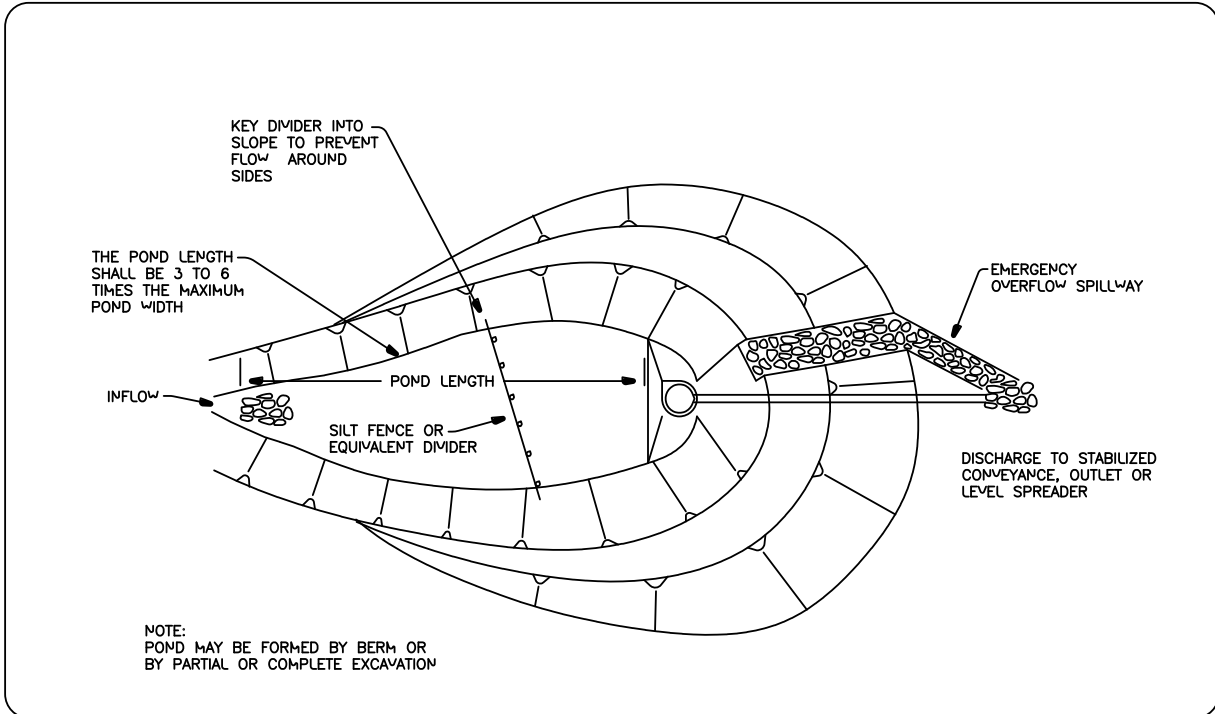
The most common structural failure of sedimentation basins is caused by piping. Piping refers to two phenomena: (1) water seeping through fine-grained soil, eroding the soil grain by grain and forming pipes or tunnels and (2) water under pressure flowing upward through a granular soil with a head of sufficient magnitude to cause soil grains to lose contact and capability for support.

The most critical construction sequences to prevent piping will be:

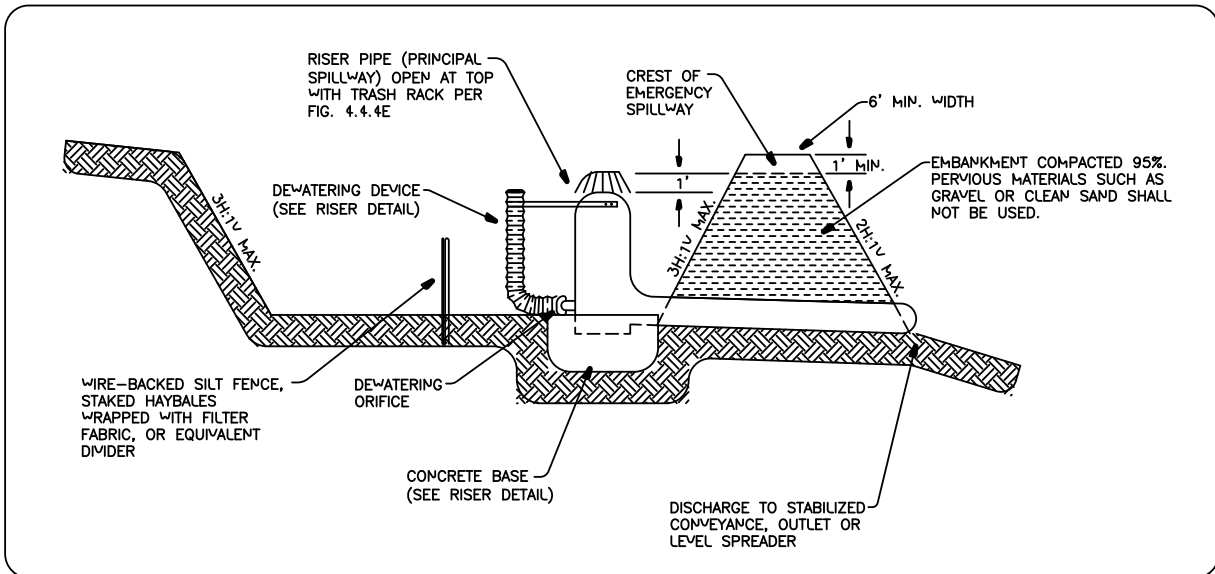
- Tight connections between the riser and barrel and other pipe connections.
- Adequate anchoring of the riser.
- Proper soil compaction of the embankment and riser footing.
- Proper construction of anti-seep devices.

### **3.2.19.4 Maintenance Standards**

- Remove sediment from the pond when it reaches 1-foot in depth.
- Repair any damage to the pond embankments or slopes.



**Figure 2 - 30. Sediment Pond**



**Figure 2 - 31. Sediment Pond Cross Section**

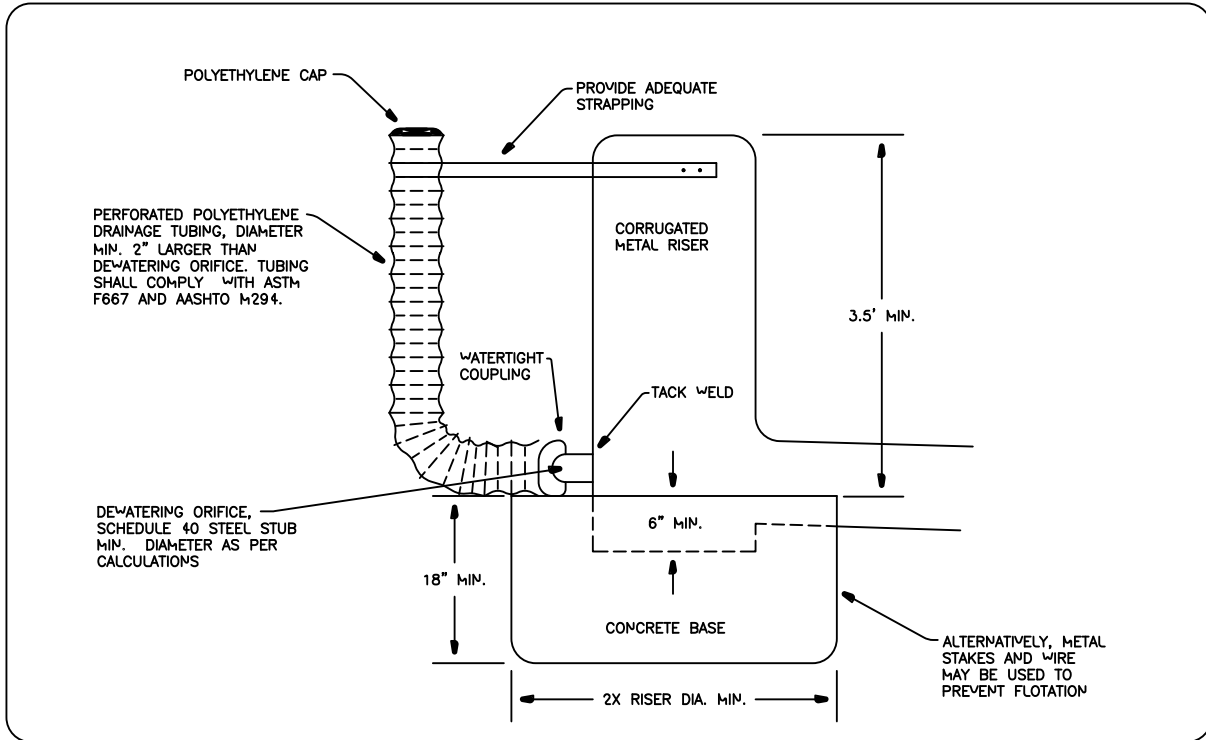


Figure 2 - 32. Sediment Pond Riser Detail

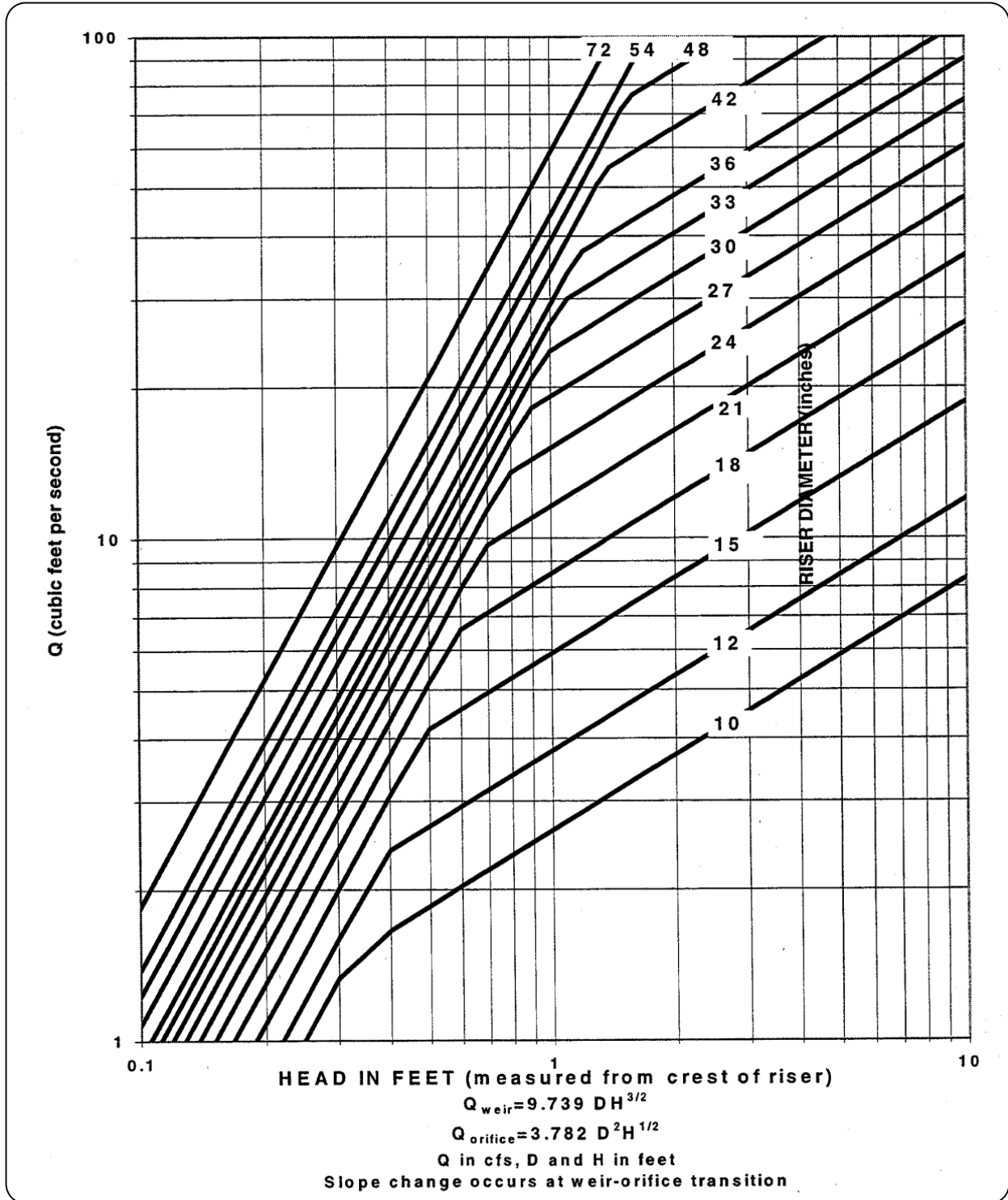


Figure 2 - 33. Riser Inflow Curves

## **3.2.20 BMP C250: Construction Stormwater Chemical Treatment**

### **3.2.20.1 Purpose**

This BMP applies when using stormwater chemicals in batch treatment or flow-through treatment.

Turbidity is difficult to control once fine particles are suspended in stormwater runoff from a construction site. Sedimentation ponds are effective at removing larger particulate matter by gravity settling, but are ineffective at removing smaller particulates such as clay and fine silt. Traditional erosion and sediment control BMPs may not be adequate to ensure compliance with the water quality standards for turbidity in the receiving water.

### **3.2.20.2 Conditions of Use**

**Formal written approval from Ecology and the City is required for the use of chemical treatment regardless of site size. When approved, include the chemical treatment system in the Stormwater Pollution Prevention Plan (SWPPP).**

### **3.2.20.3 Design and Installation Specifications**

See Appendix B for background information on chemical treatment.

#### ***Criteria for Chemical Treatment Product Use***

Chemically treated stormwater discharged from construction sites must be nontoxic to aquatic organisms. The Chemical Technology Assessment Protocol - Ecology (CTAPE) must be used to evaluate chemicals proposed for stormwater treatment. **Only chemicals approved by Ecology under the CTAPE may be used for stormwater treatment.** The approved chemicals, their allowable application techniques (batch treatment or flow-through treatment), allowable application rates, and conditions of use can be found at the Department of Ecology Emerging Technologies website: <http://www.ecy.wa.gov/programs/wq/stormwater/newtech/index.html>

#### ***Treatment System Design Considerations***

- The design and operation of a chemical treatment system should take into consideration the factors that determine optimum, cost-effective performance. It is important to recognize the following:
- Only Ecology approved chemicals may be used and must follow approved dose rates.
- The pH of the stormwater must be in the proper range for the polymers to be effective, which is typically 6.5 to 8.5.
- The coagulant must be mixed rapidly into the water to ensure proper dispersion.
- A flocculation step is important to increase the rate of settling, to produce the lowest turbidity, and to keep the dosage rate as low as possible.
- Too little energy input into the water during the flocculation phase results in floc that are too small and/or insufficiently dense. Too much energy can rapidly destroy floc as it is formed.
- Care must be taken in the design of the withdrawal system to minimize outflow velocities and to prevent floc discharge. Discharge from a batch treatment system should be directed through a physical filter such as a vegetated swale that would catch any unintended floc discharge. Currently, flow-through systems always discharge through the chemically enhanced sand filtration system.

- System discharge rates must take into account downstream conveyance integrity.

### ***Polymer Batch Treatment Process Description***

A batch chemical treatment system consists of the stormwater collection system (either temporary diversion or the permanent site drainage system), an untreated stormwater storage pond, pumps, a chemical feed system, treatment cells, and interconnecting piping.

The batch treatment system shall use a minimum of two lined treatment cells in addition to the untreated stormwater storage pond. Multiple treatment cells allow for clarification of treated water while other cells are being filled or emptied. Treatment cells may be ponds or tanks. Ponds with constructed earthen embankments greater than six feet high require special engineering analyses.

Stormwater is collected at interception point(s) on the site and is diverted by gravity or by pumping to an untreated stormwater storage pond or other untreated stormwater holding area. The stormwater is stored until treatment occurs. It is important that the holding pond be large enough to provide adequate storage.

The first step in the treatment sequence is to check the pH of the stormwater in the untreated stormwater storage pond. The pH is adjusted by the application of carbon dioxide or a base until the stormwater in the storage pond is within the desired pH range, 6.5 to 8.5. When used, carbon dioxide is added immediately downstream of the transfer pump. Typically sodium bicarbonate (baking soda) is used as a base, although other bases may be used. When needed, base is added directly to the untreated stormwater storage pond. The stormwater is recirculated with the treatment pump to provide mixing in the storage pond. Initial pH adjustments should be based on daily bench tests. Further pH adjustments can be made at any point in the process.

Once the stormwater is within the desired pH range (dependant on polymer being used), the stormwater is pumped from the untreated stormwater storage pond to a treatment cell as polymer is added. The polymer is added upstream of the pump to facilitate rapid mixing.

After polymer addition, the water is kept in a lined treatment cell for clarification of the sediment-floc. In a batch mode process, clarification typically takes from 30 minutes to several hours. Prior to discharge samples are withdrawn for analysis of pH and turbidity. If both are acceptable, the treated water is discharged.

Several configurations have been developed to withdraw treated water from the treatment cell. The original configuration is a device that withdraws the treated water from just beneath the water surface using a float with adjustable struts that prevent the float from settling on the cell bottom (Figure 2 - 34). This reduces the possibility of picking up sediment-floc from the bottom of the pond. The struts are usually set at a minimum clearance of about 12 inches; that is, the float will come within 12 inches of the bottom of the cell. Other systems have used vertical guides or cables which constrain the float, allowing it to drift up and down with the water level. More recent designs have an H-shaped array of pipes, set on the horizontal.



**Figure 2 - 34. Floating Platform with Struts**

This scheme provides for withdrawal from four points rather than one. This configuration reduces the likelihood of sucking settled solids from the bottom. It also reduces the tendency for a vortex to form. Inlet diffusers - long floating or fixed pipes with many small holes in them - are also an option.

Safety is a primary concern. Design should consider the hazards associated with operations, such as sampling. Facilities should be designed to reduce slip hazards and drowning. Tanks and ponds should have life rings, ladder, or steps extending from the bottom to the top.

### ***Polymer Flow-Through Treatment Process Description***

At a minimum, a flow-through chemical treatment system consists of the stormwater collection system (either temporary diversion or the permanent site drainage system), an untreated stormwater storage pond, and the chemically enhanced sand filtration system.

Stormwater is collected at interception point(s) on the site and is diverted by gravity or by pumping to an untreated stormwater storage pond or other untreated stormwater holding area. The stormwater is stored until treatment occurs. It is important that the holding pond be large enough to provide adequate storage.

Stormwater is then pumped from the untreated stormwater storage pond to the chemically enhanced sand filtration system where polymer is added. Adjustments to pH may be necessary before chemical addition. The sand filtration system continually monitors the stormwater for turbidity and pH. If the discharge water is ever out of an acceptable range for turbidity or pH, the water is recycled to the untreated stormwater pond where it can be retreated.

### **Equipment**

**For batch treatment and flow-through treatment**, the following equipment should be located in a lockable shed:

- The chemical injector
- Secondary non-corrosive containment for acid, caustic, buffering compound, and treatment chemical
- Emergency shower and eyewash
- Monitoring equipment

### **System Sizing**

Certain sites are required to implement flow control for the developed sites. These sites must also control stormwater release rates during construction. System sizing is dependent on flow control requirements.

#### ***Sizing Criteria for Batch Treatment Systems for Flow Control Exempt Water Bodies***

- The total volume of the untreated stormwater storage pond and treatment ponds or tanks must be large enough to treat the volume of stormwater that is produced during multiple day storm events. At a minimum, size the untreated storage pond to hold 1.5 times the runoff volume of the 10-year, 24-hour storm event assuming a Type 1A rainfall distribution (3.0-inches). Provide bypass around the chemical treatment system to accommodate extreme storm events. Calculate runoff volumes using the methods in Volume 3, Chapter 3. Use worst-case land cover conditions (i.e., producing the most runoff) for analyses (in most cases, this would be the land cover conditions just prior to final landscaping).
- Primary settling should be encouraged in the untreated stormwater storage pond. A forebay with access for maintenance is beneficial.
- There are two opposing considerations in sizing the treatment cells. A larger cell is able to treat a larger volume of water each time a batch is processed. However, the larger the cell the longer the time is required to empty the cell. A larger cell may also be less effective at flocculation and therefore require a longer settling time. The simplest approach to sizing the treatment cell is to multiply the allowable discharge flowrate times the desired drawdown time. A 4-hour drawdown time allows one batch per cell per 8-hour work period, given 1 hour of flocculation followed by 2 hours of settling.
- If the discharge is directly to a lake, flow control exempt receiving water, or to an infiltration system, there is no discharge flow limit.
- Ponds sized for flow control water bodies must be sized according to the Sizing Criteria for Flow Control Water Bodies below. If the sizing criteria shows a smaller pond size than required for Sizing Criteria for Flow Control Water Bodies, use the larger pond size.

#### ***Sizing Criteria for Flow-Through Treatment for Flow Control Exempt Water Bodies:***

- When sizing storage ponds or tanks for flow-through systems for flow control exempt water bodies, the treatment system capacity should be a factor. The untreated stormwater storage pond or tank should be sized to hold 1.5 times the runoff volume of the 10-year, 24-hour storm event assuming a Type 1A rainfall distribution (3.0-inches) minus the treatment system flowrate for an 8-hour period. For a chitosan-enhanced sand filtration system, the treatment system flowrate should be sized using a hydraulic loading



rate between 6-8 gpm/ft<sup>2</sup>. Other hydraulic loading rates may be appropriate for other systems. Bypass should be provided around the chemical treatment system to accommodate extreme storms. Runoff volume shall be calculated using the methods presented in Volume 3. Worst-case land cover conditions (i.e. producing the most runoff) should be used for analyses (in most cases, this would be the land cover conditions just prior to final landscaping).

***Sizing Criteria for Flow Control Water Bodies:***

- Sites that must implement flow control for the developed site condition must also control stormwater release rates during construction. Construction site stormwater discharges shall not exceed the discharge durations of the predeveloped condition for the range of predeveloped discharge rates from ½ of the 2-year flow through the 10-year flow as predicted by WWHM. The predeveloped condition to be matched shall be the land cover condition immediately prior to the development project. This restriction on release rates can affect the size of the storage pond and treatment cells.
- The following is how WWHM can be used to determine the release rates from the chemical treatment systems:
  1. Determine the predeveloped flow durations to be matched by entering the land use area under the “Predeveloped” scenario in WWHM. The default flow range is from ½ of the 2-year flow through the 10-year flow.
  2. Enter the post developed land use area in the “Developed Unmitigated” scenario in WWHM.
  3. Copy the land use information for the “Developed Unmitigated” to “Developed Mitigated” scenario.
  4. While in the “Developed Mitigated” scenario, add a pond element under the basin element containing the post-developed land use areas. This pond element represents information on the available untreated stormwater storage and discharge from the chemical treatment system. In cases where the discharge from the chemical treatment is controlled by a pump, a stage/storage/discharge (SSD) table representing the pond must be generated outside WWHM and imported into WWHM. WWHM can route the runoff from the post-developed condition through this SSD table (the pond) and determine compliance with the flow duration standard. This would be an iterative design procedure where if the initial SSD table proved to be inadequate, the designer would have to modify the SSD table outside WWHM and reimport in WWHM and route the runoff through it again. The iteration will continue until a pond that complies with the flow duration standard is correctly sized.

Notes on SSD table characteristics:

- The pump discharge rate would likely be initially set at just below ½ of the 2-year flow from the pre-developed condition. As runoff coming into the untreated stormwater storage pond increases and the available untreated stormwater storage volume gets used up, it would be necessary to increase the pump discharge rate above ½ of the 2-year. The increase(s) above ½ of the 2-year must be such

that they provide some relief to the untreated stormwater storage needs but at the same time will not cause violations of the flow duration standard at the higher flows. The final design SSD table will identify the appropriate pumping rates and the corresponding stage and storages.

◦When building such a flow control system, the design must ensure that any automatic adjustments to the pumping rates will be as a result of the changes to the available storage in accordance with the final design SSD table.

- It should be noted that the above procedures would be used to meet the flow control requirements. The chemical treatment system must be able to meet the runoff treatment requirements. It is likely that the discharge flowrate of  $\frac{1}{2}$  of the 2-year or more may exceed the treatment capacity of the system. If that is the case, the untreated stormwater discharge rate(s) (i.e., influent to the treatment system) must be reduced to allow proper treatment. Any reduction in the flows will likely result in the need for a larger untreated stormwater storage volume.
- If the discharge is to a municipal storm drainage system, the allowable discharge rate may be limited by the capacity of the public system. It may be necessary to clean the municipal storm drainage system prior to the start of the discharge to prevent scouring solids from the drainage system. If the municipal storm drainage system discharges to a water body that is not flow control exempt, the project site is subject to flow control requirements.
- If system design does not allow you to discharge at the slower rates as described above and if the site had a retention or detention pond that will serve the planned development, the discharge from the treatment system may be directed to the permanent retention/detention pond to comply with the flow control requirement. In this case, the untreated stormwater storage pond and treatment system will be sized according to the sizing criteria for flow-through system for flow control exempt water bodies described earlier except all discharge (water passing through the treatment system and stormwater bypassing the treatment system) will be directed into the permanent retention/detention pond. If site constraints make locating the untreated stormwater storage pond difficult, the permanent retention/detention pond may be divided to serve as the untreated stormwater storage pond and the post-treatment flow control pond. A berm or barrier must be used in this case so the untreated water does not mix with the treated water. Both untreated stormwater storage requirements, and adequate post-treatment flow control must be achieved. The post-treatment flow control pond's revised dimensions must be entered into the WWHM and the WWHM must be run to confirm compliance with the flow control requirements.

#### **3.2.20.4 Monitoring**

Conduct the following monitoring. Record test results on a daily log kept on site. Additional testing may be required by the NPDES permit based on site conditions.

##### ***Operational Monitoring:***

- Total volume treated and discharged
- Flow must be continuously monitored and recorded at not greater than 15-minute intervals
- Type and amount of chemical used for pH adjustment, if any

- Quantity of chemical used for treatment
- Settling time

### ***Compliance Monitoring***

- Influent and effluent pH and turbidity must be continuously monitored and recorded at not greater than 15-minute intervals.
- pH and turbidity of the receiving water

### ***Biomonitoring***

- Treated stormwater must be non-toxic to aquatic organisms. Treated stormwater must be tested for aquatic toxicity or residual chemical content. Frequency of biomonitoring will be determined by Ecology.
- Residual chemical tests must be approved by Ecology prior to their use.
- If testing treated stormwater for aquatic toxicity, you must test for acute (lethal) toxicity. Bioassays shall be conducted by a laboratory accredited by Ecology, unless otherwise approved by Ecology. Acute toxicity tests shall be conducted per the CTAPE protocol.

### ***Discharge Compliance***

- **Prior to discharge, treated stormwater must be sampled and tested for compliance with pH and turbidity limits.** These limits may be established by the Construction Stormwater General Permit, or a site-specific discharge permit. Sampling and testing for other pollutants may also be necessary at some sites. pH must be within the range of 6.5 to 8.5 standard units and not cause a change in the pH of the receiving water of more than 0.2 standard units.
- Treated stormwater samples and measurements shall be taken from the discharge pipe or another location representative of the nature of the treated stormwater discharge. Compliance with the water quality standards is determined in the receiving water.

### ***Operator Training***

- Each contractor who intends to use chemical treatment shall be trained by an experienced contractor. Each site using chemical treatment must have an operator trained and certified by an organization approved by Ecology.

### ***Standard BMPs***

- Surface stabilization BMPs should be implemented on site to prevent significant erosion. All sites shall use a truck wheel wash to prevent tracking of sediment off site.

### ***Sediment Removal and Disposal:***

- Remove sediment from the storage or treatment cells as necessary. Typically, sediment removal is required at least once during a wet season and at the decommissioning of the cells. Sediment remaining in the cells between batches may enhance the settling process and reduce the required chemical dosage.
- Sediment that is known to be non-toxic may be incorporated into the site away from drainages.

### **3.2.21 BMP C251: Construction Stormwater Filtration**

#### **3.2.21.1 Purpose**

Filtration removes sediment from runoff originating from disturbed areas of the site.

#### **3.2.21.2 Conditions of Use**

Traditional BMPs used to control soil erosion and sediment loss from sites under development may not be adequate to ensure compliance with the water quality standard for turbidity in the receiving water. Filtration may be used in conjunction with gravity settling to remove sediment as small as fine silt (0.5  $\mu\text{m}$ ). The reduction in turbidity will be dependent on the particle size distribution of the sediment in the stormwater. In some circumstances, sedimentation and filtration may be sufficient to achieve compliance with the water quality standard for turbidity.

The use of construction stormwater filtration does not require approval from Ecology as long as treatment chemicals are not used. Filtration in conjunction with polymer treatment requires testing under the Chemical Technology Assessment Protocol – Ecology (CTAPE) before it can be initiated. Approval from the appropriate regional Ecology office must be obtained at each site where polymers use is proposed prior to system start-up. For more guidance on stormwater chemical treatment see BMP C250.

#### **3.2.21.3 Background Information**

Filtration with sand media has been used for over a century to treat water and wastewater. The use of sand filtration for treatment of stormwater has developed recently, generally to treat runoff from streets, parking lots, and residential areas. The application of filtration to construction stormwater is currently under development.

#### **3.2.21.4 Design and Installation Specifications**

Two types of filtration systems may be applied to construction stormwater treatment: rapid and slow. Rapid sand filters are the typical system used for water and wastewater treatment. They can achieve relatively high hydraulic flow rates, on the order of 2 to 20 gpm/sf, because they have automatic backwash systems to remove accumulated solids. In contrast, slow sand filters have very low hydraulic rates, on the order of 0.02 gpm/sf, because they do not have backwash systems. To date, slow sand filtration has generally been used to treat stormwater. Slow sand filtration is mechanically simple in comparison to rapid sand filtration but requires a much larger filter area.

#### ***Filtration Equipment***

Sand media filters are available with automatic backwashing features that can filter to 50  $\mu\text{m}$  particle size. Screen or bag filters can filter down to 5  $\mu\text{m}$ . Fiber wound filters can remove particles down to 0.5  $\mu\text{m}$ . Filters should be sequenced from the largest to the smallest pore opening. Sediment removal efficiency will be related to particle size distribution in the stormwater.

#### ***Treatment Process Description***

Stormwater is collected at interception point(s) on the site and is diverted to an untreated stormwater sediment pond or tank for removal of large sediment and storage of the stormwater before it is treated by the filtration system. The untreated stormwater is pumped from the trap, pond, or tank through the filtration system in a rapid sand filtration system. Slow sand filtration systems are designed as flow through systems using gravity.

### ***Sizing Criteria for Flow-Through Treatment Systems for Flow Control Exempt Water Bodies***

When sizing storage ponds or tanks for flow-through systems for flow control exempt water bodies, the treatment system capacity should be a factor. The untreated stormwater storage pond or tank should be sized to hold 1.5 times the runoff volume of the 10-year, 24-hour storm event assuming a Type 1A rainfall distribution (3.0-inches) minus the treatment system flowrate for an 8-hour period. For a chitosan-enhanced sand filtration system, the treatment flowrate should be sized using a hydraulic loading rate between 6-8 gpm/ft<sup>2</sup>. Other hydraulic loading rates may be more appropriate for other systems. Bypass should be provided around the chemical treatment system to accommodate extreme storms. Runoff volumes shall be calculated using the methods presented in Volume 3, Chapter 3. Worst-case conditions (i.e., producing the most runoff) should be used for analyses (most likely conditions present prior to final landscaping).

### ***Sizing Criteria for Flow Control Waters:***

Sites that must implement flow control for the developed site condition must also control stormwater release rates during construction. Construction site stormwater discharges shall not exceed the discharge durations of the pre-developed condition for the range of pre-developed discharge rates from 1/2 of the 2-year flow through the 10-year flow as predicted by WWHM. The pre-developed condition to be matched shall be the land cover condition immediately prior to the development project. This restriction on release rates will affect the size of the sediment pond, the filtration system, and the flow rate through the filter system.

The following is how WWHM can be used to determine the release rates from the filtration systems:

1. Determine the pre-developed flow durations to be matched by entering the land use area under the "Pre-developed" scenario in WWHM. The default flow range is from 1/2 of the 2-year flow through the 10-year flow.
2. Enter the post developed land use area in the "Developed Unmitigated" scenario in WWHM.
3. Copy the land use information from the "Developed Unmitigated" to "Developed Mitigated" scenario.
4. There are two possible ways to model stormwater filtration systems:
  - a. The stormwater filtration system uses a storage pond/tank and the discharge from this pond/tank is pumped to one or more filters. In-line filtration chemicals would be added to the flow right after the pond/tank and before the filter(s). Because the discharge is pumped, WWHM can't generate a stage/storage/discharge (SSD) table for this system. This system is modeled the same way as described in BMP C250 and is as follows:

While in the "Developed Mitigated" scenario, add a pond element under the basin element containing the post-developed land use areas. This pond element represents information on the available storage and discharge from the filtration system. In cases where the discharge from the filtration system is controlled by a pump, a stage/storage/discharge (SSD) table representing the pond must be generated outside WWHM and imported into WWHM. WWHM can route the runoff from the post-developed condition through this SSD table (the pond) and determine compliance with the flow duration standard. This would be

an iterative design procedure where if the initial SSD table proved to be out of compliance, the designer would have to modify the SSD table outside WWHM and re-import in WWHM and route the runoff through it again. The iteration will continue until a pond that enables compliance with the flow duration standard is designed.

#### Notes on SSD Table Characteristics

- The pump discharge rate would likely be initially set at just below  $\frac{1}{2}$  of the 2-year flow from the pre-developed condition. As runoff coming to the storage pond increases and the available storage volume gets used up, it would be necessary to increase the pump discharge rate above  $\frac{1}{2}$  of the 2-year. The increase(s) above  $\frac{1}{2}$  of the 2-year must be such that they provide some relief to the storage needs but at the same time they will not cause violations of the flow duration standard at the higher flows. The final design SSD table will identify the appropriate pumping rates and the corresponding stage and storages.
  - When building such a flow control system, the design must ensure that any automatic adjustments to the pumping rates will be as a result of changes to the available storage in accordance with the final design SSD table.
- b. The stormwater filtration system uses a storage pond/tank and the discharge from this pond/tank gravity flows to the filter. This is usually a slow sand filter system and it is possible to model it in WWHM as a Filter element or as a combination of Pond and Filter element placed in series. The stage/storage/discharge table(s) may then be generated within WWHM as follows:
- (i) While in the “Developed Mitigated” scenario, add a Filter element under the basin element containing the post-developed land use areas. The length and width of this filter element would have to be the same as the bottom length and width of the upstream storage pond/tank.
  - (ii) In cases where the length and width of the filter is not the same as those for the bottom of the upstream storage tank/pond, the treatment system may be modeled as a Pond element followed by a Filter element. By having these two elements, WWHM would then generate a SSD table for the storage pond which then gravity flows to the Filter element. The Filter element downstream of the storage pond would have a storage component through the media, and an overflow component for when the filtration capacity is exceeded.
- WWHM can route the runoff from the post-developed condition through the treatment systems in 4b and determine compliance with the flow duration standard. This would be an iterative design procedure where if the initial sizing estimates for the treatment system proved to be inadequate, the designer would have to modify the system and route the runoff through it again. The iteration would continue until compliance with the flow duration standard is achieved.
5. It should be noted that the above procedures would be used to meet the flow control requirements. The filtration system must be able to meet the runoff treatment requirements. It is likely that the discharge flow rate of  $\frac{1}{2}$  of the 2-year or more may exceed the treatment

capacity of the system. If that is the case, the discharge rate(s) must be reduced to allow proper treatment. Any reduction in the flows would likely result in the need for a larger storage volume.

If the system does not allow you to discharge at the slower rate as described above and if the site has a retention or detention pond that will serve the planned development, the discharge from the treatment system may be directed to the permanent retention/detention pond to comply with the flow control requirements. In this case, the untreated stormwater storage pond and treatment system will be sized according to the sizing criteria for flow-through treatment systems for flow control exempt waterbodies except all discharges (water passing through the treatment system and stormwater bypassing the treatment system) will be directed into the permanent retention/detention pond. If site constraints make locating the untreated stormwater storage pond difficult, the permanent retention/detention pond may be divided to serve as the untreated stormwater discharge pond and the post-treatment flow control pond. A berm or barrier must be used in this case so the untreated water does not mix with the treated water. Both untreated stormwater storage requirements, and adequate post-treatment flow control must be achieved. The post-treatment flow control pond's revised dimensions must be entered into the WWHM and the WWHM must be run to confirm compliance with the flow control requirements.

### **3.2.21.5 Maintenance Standards**

- Rapid sand filters typically have automatic backwash systems that are triggered by a pre-set pressure drop across the filter. If the backwash water volume is not large or substantially more turbid than the untreated stormwater stored in the holding pond or tank, backwash return to the untreated stormwater pond or tank may be appropriate. However, land application or another means of treatment and disposal may be necessary.
- Clean and/or replace screen, bag, and fiber filters when they become clogged.
- Remove sediment from the storage and/or treatment ponds as necessary. Typically, sediment removal is required once or twice during a wet season and at the decommissioning of the ponds.

### **3.2.22 BMP C252: High pH Neutralization using CO<sub>2</sub>**

#### **3.2.22.1 Description**

When pH levels in stormwater rise above 8.5 it is necessary to lower the pH levels to the acceptable range of 6.5 to 8.5, this process is called pH neutralization. pH neutralization involves the use of solid or compressed carbon dioxide gas in water requiring neutralization. Neutralized stormwater may be discharged to surface waters under the General Construction NPDES permit but neutralized process wastewater must be managed to prevent discharge to surface waters. Process wastewater includes wastewaters such as concrete truck wash-out, hydro-demolition, or saw-cutting slurry. Any stormwater contaminated during concrete work is considered process wastewater and must not be discharged to surface water.

#### ***Reason for pH neutralization***

A pH level range of 6.5 to 8.5 is typical for most natural watercourses, and this neutral pH is required for the survival of aquatic organisms. Should the pH rise or drop out of this range, fish and other aquatic organisms may become stressed and may die.

Calcium hardness can contribute to high pH values and cause toxicity that is associated with high pH conditions. A high level of calcium hardness in waters of the state is not allowed.

The water quality standard for pH in Washington State is in the range of 6.5 to 8.5.

Groundwater standard for calcium and other dissolved solids in Washington State is less than 500 mg/l.

### ***Causes of high pH***

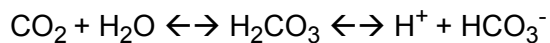
High pH at construction sites is most commonly caused by the contact of stormwater with poured or recycled concrete, cement, mortars, and other Portland cement or lime-containing construction materials. (See BMP C151: Concrete Handling for more information on concrete handling procedures). The principal caustic agent in cement is calcium hydroxide (free lime).

### ***Advantages of CO<sub>2</sub> Sparging***

- Rapidly neutralizes high pH water.
- Cost effective and safer to handle than acid compounds.
- CO<sub>2</sub> is self-buffering. It is difficult to overdose and create harmfully low pH levels.
- Material is readily available.

### ***The Chemical Process***

When carbon dioxide (CO<sub>2</sub>) is added to water (H<sub>2</sub>O), carbonic acid (H<sub>2</sub>CO<sub>3</sub>) is formed which can further dissociate into a proton (H<sup>+</sup>) and a bicarbonate anion (HCO<sub>3</sub><sup>-</sup>) as shown below:



The free proton is a weak acid that can lower the pH.

Water temperature has an effect on the reaction as well. The colder the water temperature is the slower the reaction occurs and the warmer the water temperature is the quicker the reaction occurs. Most construction applications in Washington State have water temperatures in the 50°F or higher range so the reaction is almost simultaneous.

### **3.2.22.2 Treatment Procedures**

High pH water may be treated using continuous treatment, continuous discharge systems. These manufactured systems continuously monitor influent and effluent pH to ensure that pH values are within an acceptable range before being discharged. All systems must have fail safe automatic shut off switches in the event that pH is not within the acceptable discharge range. Only trained operators may operate manufactured systems. System manufacturers often provide trained operators or training on their devices.

The following procedure may be used when not using a continuous discharge system:

- Prior to treatment, the appropriate jurisdiction should be notified in accordance with the regulations set by the jurisdiction.
- Every effort should be made to isolate the potential high pH water in order to treat it separately from other stormwater onsite.
- Water should be stored in an acceptable storage facility, detention pond, or containment cell prior to treatment.



- Transfer water to be treated to the treatment structure. Ensure that treatment structure size is sufficient to hold the amount of water that is to be treated. Do not fill tank completely, allow at least 2 feet of freeboard.
- The operator samples the water for pH and notes the clarity of the water. As a rule of thumb, less CO<sub>2</sub> is necessary for clearer water. This information should be recorded.
- In the pH adjustment structure, add CO<sub>2</sub> until the pH falls in the range of 6.9-7.1. Remember that pH water quality standards apply so adjusting pH to within 0.2 pH units of receiving water (background pH) is recommended. It is unlikely that pH can be adjusted to within 0.2 pH units using dry ice. Compressed carbon dioxide gas should be introduced to the water using a carbon dioxide diffuser located near the bottom of the tank, this will allow carbon dioxide to bubble up through the water and diffuse more evenly.
- Slowly release the water to discharge making sure water does not get stirred up in the process. Release about 80% of the water from the structure leaving any sludge behind.
- Discharge treated water through a pond or drainage system.
- Excess sludge needs to be disposed of properly as concrete waste. If several batches of water are undergoing pH treatment, sludge can be left in treatment structure for the next batch treatment. Dispose of sludge when it fills 50% of tank volume.

Sites that must implement flow control for the developed site must also control stormwater release rates during construction. All treated stormwater must go through a flow control facility before being released to surface waters which require flow control.

### **3.2.22.3 Safety and Materials Handling**

- All equipment should be handled in accordance with OSHA rules and regulations.
- Follow manufacturer guidelines for materials handling.

### **3.2.22.4 Operator Records**

Each operator should provide:

- A diagram of the monitoring and treatment equipment
- A description of the pumping rates and capacity the treatment equipment is capable of treating.

Each operator should keep a written record of the following:

- Client name and phone number
- Date of treatment
- Weather conditions
- Project name and location
- Volume of water treated
- pH of untreated water
- Amount of CO<sub>2</sub> needed to adjust water to a pH range of 6.9-7.1
- pH of treated water
- Discharge point location and description

A copy of this record should be given to the client/contractor who should retain the record for three years.

### **3.2.23 BMP C253: pH Control for High pH Water**

#### **3.2.23.1 Description**

When pH levels in stormwater rise above 8.5 it is necessary to lower the pH levels to the acceptable range of 6.5 to 8.5, this process is called pH neutralization. Stormwater with pH levels exceeding water quality standards may be treated by infiltration, dispersion in vegetation or compost-amended soils meeting BMP L613 Post-Construction Soil Quality and Depth, pumping to a sanitary sewer, disposal at a permitted concrete batch plant with pH neutralization capabilities, or carbon dioxide sparging. BMP C252 provides guidance for carbon dioxide sparging.

#### ***Reason for pH neutralization***

A pH level between 6.5 and 8.5 is typical for most natural watercourses, and this pH range is required for the survival of aquatic organisms. Should the pH rise or drop out of this range, fish and other aquatic organisms may become stressed and may die.

#### ***Causes of high pH***

High pH levels at construction sites are most commonly caused by the contact of stormwater with poured or recycled concrete, cement, mortars, and other Portland cement or lime-containing construction materials. (See BMP C151: Concrete Handling for more information on concrete handling procedures). The principal caustic agent in cement is calcium hydroxide (free lime).

#### **3.2.23.2 Disposal Methods**

##### ***Infiltration***

- Infiltration is only allowed if soil type allows all water to infiltrate (no surface runoff) without causing or contributing to a violation of surface or groundwater quality standards.
- Infiltration techniques should be consistent with Volume 5, Chapter 5.

##### ***Dispersion***

- Use BMP L614 Full Dispersion

##### ***Sanitary Sewer Disposal***

- A Special Approved Discharge (SAD) permit will be required for discharge to the sanitary sewer. Contact Source Control at 253.591.5588 for information on the SAD permit.

##### ***Concrete Batch Plant Disposal***

- Only permitted facilities may accept high pH water.
- Facility should be contacted before treatment to ensure they can accept the high pH water.

##### ***Stormwater Discharge***

Any pH treatment options that generate treated water that must be discharged off site are subject to flow control requirements. Sites that must implement flow control for the developed site must also control stormwater release rates during construction. All treated stormwater must go through a flow control facility before being released to surface waters which require flow control.

**This Page Intentionally Left Blank**

## **Appendix A Standard Notes for Temporary Erosion and Sedimentation Control Plans**

The following standard notes shall be included on project drawings for projects exceeding the thresholds for a short form SWPPP and are recommended to be included on drawings for all projects. Plans shall identify the name and phone number of the person or firm responsible for the preparation and maintenance of the erosion control plan.

### ***Standard TESC Notes***

1. The implementation of these TESC plans and the construction, maintenance, replacement, and upgrading of TESC facilities is the responsibility of the applicant/contractor until all construction is completed and approved, vegetation/landscaping is established and the entire site is stabilized.
2. The boundaries of the clearing limits shown on this plan shall be clearly marked in the field prior to construction. During the construction period, no disturbance beyond the clearing limits shall be permitted. The marking shall be maintained by the applicant/contractor for the duration of construction.
3. The TESC facilities shown on this plan shall be constructed prior to and/or in conjunction with all clearing and grading activities, and in such a manner as to ensure that sediment and sediment laden water do not enter the drainage system or roadways, or violate applicable water standards.
4. The TESC facilities shown on this plan are the minimum requirements for anticipated site conditions. During the construction period, TESC facilities shall be upgraded as needed for unexpected storm events and to ensure that sediment and sediment-laden water do not leave the site.
5. The CESCL, CPESC, or ESC Lead shall be identified in the SWPPP and shall be onsite or on-call at all times.
6. The CESCL, CPESC, or ESC Lead must be knowledgeable in the principles and practices of erosion and sediment control and have the skills to assess:
  - a. Site conditions and construction activities that could impact the quality of stormwater.
  - b. Effectiveness of erosion and sediment control measures used to control the quality of stormwater discharges.
7. The CESCL, CPESC, or ESC Lead must examine stormwater visually for the presence of suspended sediment, turbidity, discoloration, and oil sheen and evaluate the effectiveness of BMPs to determine if it is necessary to install, maintain, or repair BMPs.
8. The CESCL, CPESC, or ESC Lead must inspect all areas disturbed by construction activities, all BMPs, and all stormwater discharge points at least once every calendar week and within 24 hours of any discharge from the site. (Individual discharge events that last more than one day do not require daily inspections). The CESCL or inspector may reduce the inspection frequency for temporary stabilized, inactive sites to once every calendar month.
9. Construction site operators must correct any problems identified by the CESCL, CPESC, or ESC Lead by:

- a. Reviewing the SWPPP for compliance with the 13 construction SWPPP elements and making appropriate revisions within 7 days of the inspection.
- b. Fully implement and maintain appropriate source control and/or treatment BMPs as soon as possible but correcting the problem within 10 days.
- c. Documenting BMP implementation and maintenance in the site log book. (Required for sites larger than 1 acre but recommended for all sites).

Sampling and analysis of the stormwater discharges from a construction site may be necessary on a case-by-case basis to ensure compliance with standards. Ecology or the City will establish these monitoring and associated reporting requirements.

10. At no time shall more than one foot of sediment be allowed to accumulate within a catch basin sediment trap.
11. All catch basins and conveyance lines shall be cleaned prior to paving. The cleaning operation shall not flush sediment-laden water into the downstream system.
12. Stabilized construction entrances shall be installed at the beginning of construction and maintained for the duration of the project. Additional measures may be required to ensure that all paved areas are kept clean for the duration of the project.

## **Appendix B Construction SWPPP Short Form**

Projects falling within the thresholds listed below may use this short form instead of preparing a formal Construction Stormwater Pollution Prevention Plan (SWPPP). If your project meets the following thresholds and includes or may impact a critical area, please contact the City to determine if the SWPPP short form may be used.

The short form may be used if any of the following criteria are met:

- Add or replace between 2,000 and 5,000 square feet of impervious surface.
- Clear or disturb between 7,000 square feet and 1 acre of land.
- Grade/fill 50-499 cubic yards.

If project quantities exceed any of the above thresholds, prepare a Long Form Construction SWPPP as described in Chapter 2 of Volume 2.

# City of Tacoma

## Construction Stormwater Pollution Prevention Plan Short Form

Project Name: \_\_\_\_\_

Address: \_\_\_\_\_

Contact/Owner: \_\_\_\_\_ Phone: \_\_\_\_\_

E-mail: \_\_\_\_\_

Erosion Control Lead: \_\_\_\_\_

Phone: \_\_\_\_\_ Cell: \_\_\_\_\_ Email: \_\_\_\_\_

Emergency (After hour) contact: \_\_\_\_\_ Phone: \_\_\_\_\_

Permit No: \_\_\_\_\_

Parcel No.: \_\_\_\_\_

Date Submitted: \_\_\_\_\_

### **Required Submittals**

A Construction Stormwater Pollution Prevention Plan consists of both a project narrative and a site plan. The project narrative describes the existing conditions on the site, the proposed conditions, and how construction site runoff will be managed until final site stabilization. Any additional relevant information should be included in the project narrative.

The site plan is a drawing which shows the location of the proposed BMPs. The Site Plan is described in Section 2 below.

The information required in Section 1 below is the project narrative. All Best Management Practices (BMPs) that will be utilized onsite shall be printed (or provided electronically - depending upon permit submittal method) and included as part of the project narrative. If additional best management practices beyond those included in the SWMM will be used, a narrative and appropriate details describing the BMP (its function, installation method, and maintenance activities) will be required.

The City of Tacoma govMe site (<http://www.govme.org>) may be used to find much of the information needed to complete this form, such as adjacent areas, topography, critical areas, the downstream drainage path, and information concerning onsite features.

**1. Project Narrative**

**NOTE:** From October 1 thru April 30, clearing, grading, and other soil disturbing activities shall only be permitted by special authorization from the City of Tacoma Planning and Development Services. (TMC 2.19.030)

**A. Project Description (Check all boxes and complete all text fields that apply)**

- New Structure/Building   
  Building Addition   
  Grading/Excavation   
  Paving  
 Utilities                     
  Other: \_\_\_\_\_

**Table 2 - 16: Project Threshold Worksheet**

Description <sup>a</sup>	Onsite	Offsite	Total
<b>Existing Conditions</b>			
Total Project Area <sup>b</sup> (ft <sup>2</sup> )			
Existing hard surface (ft <sup>2</sup> )			
Existing vegetation area (ft <sup>2</sup> )			
<b>Existing Conditions</b>			
Total Project Area <sup>b</sup> (ft <sup>2</sup> )			
Amount of new hard surface (ft <sup>2</sup> )			
Amount of new pollution generating hard surface (PGHS) <sup>c</sup> (ft <sup>2</sup> )			
Amount of replaced hard surface (ft <sup>2</sup> )			
Amount of replaced PGHS <sup>d</sup> (ft <sup>2</sup> )			
Amount of new plus replaced hard surface (ft <sup>2</sup> )			
Amount of new + replaced PGHS (ft <sup>2</sup> )			
Amount of existing hard surfaces converted to vegetation (ft <sup>2</sup> )			
Amount of Land Disturbed (ft <sup>2</sup> )			
Vegetation to Lawn/Landscaped (acres)			
Native Vegetation to Pasture (acres)			
Existing vegetation area to remain (ft <sup>2</sup> )			
Existing hard surface to remain unaltered (ft <sup>2</sup> )			

a. All terms are defined in the SWMM glossary.  
 b. The total project area in the existing condition should typically match the total project area in the proposed condition.  
 c. The “amount of new PGHS” should be part of or all of “amount of new hard surfaces”.  
 d. The “amount of replaced PGHS” should be part of or all of “amount of replaced hard surfaces”

Additional Project Information: \_\_\_\_\_

\_\_\_\_\_



**B. Existing Site Conditions (Check all boxes and complete all text fields that apply)**

1. Describe the existing conditions on the site. (Check all that apply)
  - Forest  Pasture/prairie grass  Pavement  Landscaping  Brush
  - Trees  Other \_\_\_\_\_
2. Describe how surface water (stormwater) drainage flows across/from the site. (Check all that apply)
  - Sheet Flow  Gutter  Catch Basin  Ditch/Swale  Storm sewer
  - Stream  Other \_\_\_\_\_
3. Describe any unusual site condition(s) or other features of note.
  - Steep Grades  Large depression  Underground tanks  Springs
  - Easements  Existing Structures  Existing Utilities
  - Other \_\_\_\_\_
4. Is the site located within the South Tacoma Groundwater Protection District?
  - Yes  No

**C. Adjacent Areas (Check all boxes and complete all text fields that apply)**

1. Check any adjacent areas that may be affected by site disturbance and fully describe in item 2 below:
  - Streams\*  Lakes\*  Wetlands\*  Steep Slopes\*
  - Residential Areas  Roads  Ditches, pipes, culverts
  - Other \_\_\_\_\_

*\* If site is on or adjacent to a critical area, the City of Tacoma may require additional information, engineering, and other permits to be submitted prior to permit approval.*

2. Describe how and where surface water enters the site from upstream properties:

---



---



---



---

3. Describe the downstream drainage path leading from the site to the receiving body of water. (Minimum distance of ¼-mile (1320 feet)) {E.g. water flows from site, into curb-line to catch basin at intersection of X and Y streets. A 10-inch pipe system conveys water another 1000 feet to a ravine/wetland.} Include information on the condition of the drainage structures.

---



---



---



---



---

**D. Soils Information**

If the project is proposing construction on or near slopes 15% or greater or proposing to infiltrate construction site stormwater runoff, the City may require that additional soils information be presented before allowing construction on these sites.

1. Does the project propose construction on or near slopes 15% or greater?  
 Yes       No
  
2. Does the project propose to infiltrate construction stormwater?  
 Yes       No

**E. 13 Elements of a Construction SWPPP**

The following 13 elements are required for each SWPPP. If an element does not apply to the project site describe why the element does not apply. Check off those BMPs that are proposed to be used to meet the requirements of the 13 elements below. Everything that is checked below should be shown on the site plan. If a BMP is checked as a possible contingent BMP, state that in this report. Only those erosion and sediment control techniques most pertinent to small construction sites are included here. More detailed information on construction BMPs can be found in Volume 2 of the City of Tacoma Stormwater Management Manual. The BMP numbers referenced are BMPs located in the City of Tacoma SWMM. Print or attach those BMPs that will be used for the project and include as part of this Construction SWPPP. BMPs that may be used if needed can be noted as being contingent in the event additional erosion control is required. Describe any additional BMPs that will be utilized on the site and add them to the Short Form SWPPP.

For phased construction plans, clearly indicate erosion control methods to be used for each phase of construction.

*Element #1 – Preserve Vegetation and Mark Clearing Limits*

Retain the duff layer, native topsoil, and natural vegetation in an undisturbed state to the maximum extent practicable. If it is not practicable to retain the duff layer in place, it should be

stockpiled onsite, covered to prevent erosion, and replaced immediately upon completion of the ground-disturbing activity.

All construction projects must clearly mark any clearing limits, sensitive areas and their buffers, and any trees that will be preserved prior to beginning any land disturbing activities, including clearing and grading. Clearly mark the limits both in the field and on the plans. Limits shall be marked in such a way that any trees or vegetation to remain will not be harmed. See Figure 3 - 13 of the SWMM.

- The BMP(s) being proposed to meet this element are:
  - BMP C101: Preserving Natural Vegetation
  - BMP C102: Buffer Zones
  - BMP C103: High Visibility Fence
  - BMP C233: Silt Fence
  - Other (Describe Method) \_\_\_\_\_

Or

- This element is not required for this project because: \_\_\_\_\_  
 \_\_\_\_\_  
 \_\_\_\_\_

*Element #2 – Establish Construction Access*

All construction projects subject to vehicular traffic shall provide a means of preventing vehicle “tracking” of soil from the site onto City streets or neighboring properties. Limit vehicle ingress and egress to one route if possible. All access points shall be stabilized with a rock pad construction entrance per BMP C105 or other City of Tacoma approved BMP. The applicant should consider placing the entrance in the area for future driveway(s), as it may be possible to use the rock as a driveway base material. The entrance(s) must be inspected weekly, at a minimum, to ensure no excess sediment buildup or missing rock.

If sediment is tracked offsite, it shall be swept or shoveled from the paved surface immediately. Keep streets clean at all times. Street washing for sediment removal is not allowed as it can transport sediment to downstream water courses and clog the downstream stormwater system.

The proposed construction entrance must be identified on the site plan.

- The BMP(s) being proposed to meet this element are:
  - BMP C105: Stabilized Construction Entrance/Exit
  - BMP C107: Construction Road/Parking Area Stabilization
  - Other (Describe Method) \_\_\_\_\_

Or

- This element is not required for this project because: \_\_\_\_\_  
 \_\_\_\_\_  
 \_\_\_\_\_

*Element #3 – Control Flow Rates*

Protect properties and waterways downstream of the development site from erosion due to increases in volume, velocity, and peak flow of stormwater runoff from the project site.

Permanent infiltration facilities shall not be used for flow control during construction unless specifically approved in writing by Environmental Services. Sediment traps can provide flow control for small sites by allowing water to pool and allowing sediment to settle out of the water.

- The BMP(s) being proposed to meet this element are:
  - BMP C203: Water Bars
  - BMP C207: Check Dams
  - BMP C209: Outlet Protection
  - BMP C235: Wattles
  - BMP C240: Sediment Trap
  - Other (Describe Method) \_\_\_\_\_

Or

- This element is not required for this project because:  
\_\_\_\_\_  
\_\_\_\_\_  
\_\_\_\_\_

*Element #4 – Install Sediment Controls*

Prior to leaving a construction site or discharging into an infiltration facility, surface water runoff from disturbed areas must pass through an appropriate sediment removal device. Sediment barriers are typically used to slow sheet flow of stormwater and allow the sediment to settle out behind the barrier.

Install/construct the sediment removal BMP before site grading.

The BMP(s) being proposed to meet this element are:

- BMP C233: Silt Fence
- BMP C234: Vegetated Strip
- BMP C235: Wattles
- BMP C240: Sediment Trap
- Other (Describe Method)

---



---

Or

This element is not required for this project because:

---



---



---

*Element #5 – Stabilize Soils*

Stabilize exposed and unworked soils by applying BMPs that protect the soils from raindrop impact, flowing water, and wind. Minimize the amount of soil exposed during construction activity. Minimize the disturbance of steep slopes. Minimize soil compaction and, unless infeasible, preserve topsoil.

From October 1 through April 30, no soils shall remain exposed or unworked for more than 2 days. From May 1 to September 30, no soils shall remain exposed and unworked for more than 7 days. This applies to all soils on site whether at final grade or not.

The BMP(s) being proposed to meet this element are:

- BMP C120: Temporary and Permanent Seeding
- BMP C121: Mulching
- BMP C122: Nets and Blankets
- BMP C123: Plastic Covering
- BMP C124: Sodding
- BMP C125: Compost
- BMP C126: Topsoiling
- BMP C140: Dust Control
- Other (Describe Method)

---

Or

This element is not required for this project because:

---



---



---

*Element #6 – Protect Slopes*

Design and construct cut-and-fill slopes in a manner to minimize erosion.

Protect slopes by diverting water at the top of the slope. Reduce slope velocities by minimizing the continuous length of the slope, which can be accomplished by terracing and roughening slope sides. Establishing vegetation on slopes will protect them as well.

- The BMP(s) being proposed to meet this element are:
  - BMP C120: Temporary and Permanent Seeding
  - BMP C121: Mulching
  - BMP C122: Nets and Blankets
  - BMP C200: Interceptor Dike and Swale
  - BMP C203: Water Bars
  - BMP C204: Pipe Slope Drains
  - BMP C205: Subsurface Drains
  - BMP C207: Check Dams
  - BMP C208: Triangular Silt Dike
  - Other (Describe Method)\_\_\_\_\_

Or

- This element is not required for this project because:
   
\_\_\_\_\_
   
\_\_\_\_\_
   
\_\_\_\_\_

*Element #7 – Protect Drain Inlets*

Protect all storm drain inlets that are operable during construction so that stormwater runoff does not enter the conveyance system without first being filtered or treated to remove sediment. Install catch basin protection on all catch basins within 500 feet downstream of the project. The catch basin inlet protection shown in Figure 2-45 is the only catch basin protection allowed within the City right of way. Once the site is fully stabilized, catch basin protection must be removed.

- The BMP(s) being proposed to meet this element are:
  - BMP C220: Storm Drain Inlet Protection
  - Other (Describe Method)\_\_\_\_\_

Or

- This element is not required for this project because:
   
\_\_\_\_\_
   
\_\_\_\_\_
   
\_\_\_\_\_

*Element #8 – Stabilize Channels and Outlets*

Stabilize all temporary onsite conveyance channels. Provide stabilization to prevent erosion of outlets, adjacent stream banks, slopes, and downstream reaches at the outlets of conveyance systems.

- The BMP(s) being proposed to meet this element are:
  - BMP C122: Nets and Blankets
  - BMP C202: Channel Lining
  - BMP C207: Check Dams
  - BMP C209: Outlet Protection
  - Other (Describe Method)\_\_\_\_\_

Or

- This element is not required for this project because:
   
\_\_\_\_\_
   
\_\_\_\_\_
   
\_\_\_\_\_

*Element #9 – Control Pollutants*

Handle and dispose of all pollutants, including demolition debris and other solid wastes in a manner that does not cause contamination of the stormwater. Provide cover and containment for all chemicals, liquid products (including paint), petroleum products, and other materials. Handle all concrete and concrete waste appropriately. All discharges to the City sanitary sewer system require City approval, which may include a Special Approved Discharge (SAD) permit.

- The BMP(s) being proposed to meet this element are:
  - BMP C151: Concrete Handling
  - BMP C152: Sawcutting and Surfacing Pollution Prevention
  - BMP C153: Material Delivery, Storage, and Containment
  - BMP C154: Concrete Washout Area
  - Other (Describe Method)\_\_\_\_\_

Or

- This element is not required for this project because:
   
\_\_\_\_\_
   
\_\_\_\_\_
   
\_\_\_\_\_

*Element #10 – Control Dewatering*

Clean, non-turbid dewatering water, such as groundwater, can be discharged to the stormwater system provided the dewatering flow does not cause erosion or flooding of receiving waters. All other water shall be discharged to the City sewer system.

All discharges to the City sewer system require City approval, which may include a Special Approved Discharge (SAD) permit. Dewatering water must be discharged through a stabilized channel to a sediment pond or trap.

- The BMP(s) being proposed to meet this element are:
  - BMP C203: Water Bars
  - BMP C236: Vegetative Filtration
  - Other (Describe Method)\_\_\_\_\_

Or

- This element is not required for this project because:
   
\_\_\_\_\_
   
\_\_\_\_\_
   
\_\_\_\_\_

*Element #11 – Maintain BMPs*

Maintain and repair temporary erosion and sediment control BMPs as needed. Inspect all BMPs at least weekly and after every storm event.

Remove all temporary erosion and sediment control BMPs within 30 days after final site stabilization or if the BMP is no longer needed. Any trapped sediment should be removed or stabilized onsite. No sediment shall be discharged into the storm drainage system or natural conveyance systems.

- The BMP(s) being proposed to meet this element are:
  - BMP C150: Materials on Hand
  - BMP C160: Erosion and Sediment Control Lead
  - Other (Describe Method)\_\_\_\_\_

Or

- This element is not required for this project because:
   
\_\_\_\_\_
   
\_\_\_\_\_
   
\_\_\_\_\_



*Element #12 – Manage the Project*

Phase development projects in order to prevent soil erosion and the transport of sediment from the project site during construction.

Coordinate all work before initial construction with subcontractors and other utilities to ensure no areas are prematurely worked.

An Erosion Control Lead is required for all construction sites. The Erosion Control Lead is the party responsible for ensuring that the proposed erosion and sediment control BMPs are appropriate for the site and are functioning. They are also responsible for updating the SWPPP as necessary as site conditions warrant. They must be available 24 hours a day to ensure compliance.

- The BMP(s) being proposed to meet this element are:
  - BMP C150: Materials on Hand
  - BMP C160: Erosion and Sediment Control Lead
  - BMP C162: Scheduling
  - Other (Describe Method)\_\_\_\_\_
 Or

- This element is not required for this project because:
   
\_\_\_\_\_
   
\_\_\_\_\_
   
\_\_\_\_\_

*Element #13 – Protect BMPs*

Protect all BMPs from sedimentation through installation and maintenance of erosion and sediment control BMPs on portions of the site that drain into the BMPs. Restore all BMPs to their fully functioning condition if they accumulate sediment during construction. Restoring the BMP shall include removal of all sediment. Keep heavy equipment off of infiltration surfaces.

- BMP C102: Buffer Zone
- BMP C103: High Visibility Fence
- BMP C200: Interceptor Dike and Swale
- BMP C201: Grass-Lined Channels
- BMP C207: Check Dams
- BMP C208: Triangular Silt Dike (TSD) (Geotextile-Encased Check Dam)
- BMP C231: Brush Barrier
- BMP C233: Silt Fence
- BMP C234: Vegetated Strip
- Other (Describe Method)\_\_\_\_\_

Construction Sequencing/Phasing

1. The standard construction sequence is as follows:
  - Mark clearing/grading limits.
  - Call Site Development Inspector to inspect clearing/grading limits.
  - Install initial erosion control practices (construction entrance, silt fence, catch basin inserts).

- Contact Site Development Inspector to inspect initial erosion control practices.
- Clear, grade, and fill site as outlined in the site plan while implementing and maintaining temporary erosion and sediment control practices at the same time.
- Install proposed site improvements (impervious surface, landscaping, etc.).
- Contact Site Development Inspector for approval of permanent erosion protection and site grades.
- Remove erosion control methods as permitted by the Site Development Inspector and repair permanent erosion protection as necessary.
- Monitor and maintain permanent erosion protection until fully established.

List any changes from the standard construction sequence outlined above.

---

---

---

---

---

2. Construction phasing: If construction is going to occur in separate phases, describe:

---

---

---

---

---

Construction Schedule

1. Provide a proposed construction schedule (dates construction starts and ends, and dates for any construction phasing).

Start Date: \_\_\_\_\_ End Date: \_\_\_\_\_

Interim Phasing Dates: \_\_\_\_\_

Wet Season Construction Activities: *Wet season occurs from October 1 to April 30.*

Describe construction activities that will occur during this time period.

---

---

---

---

---

**NOTE:** Additional erosion control measures beyond those shown may be required to manage site runoff.

## 2. Site Plan (See Figure 2 - 35 for an Example)

Much of the information needed for developing a site plan is available on the City of Tacoma govMe website at <http://www.govme.org>.

### Onsite field verification of actual conditions is required.

A site plan, to scale, shall be included with this checklist that shows the following items:

- \_\_\_\_\_ a. Address, Parcel Number, Permit Number and Street names
- \_\_\_\_\_ b. North Arrow
- \_\_\_\_\_ c. Indicate boundaries of existing vegetation (e.g. tree lines, grassy areas, pasture areas, fields, etc.)
- \_\_\_\_\_ d. Identify any on-site or adjacent critical areas and associated buffers (e.g. wetlands, steep slopes, streams, etc.).
- \_\_\_\_\_ e. Show existing and proposed contours.
- \_\_\_\_\_ f. Delineate areas that are to be cleared and graded.
- \_\_\_\_\_ g. Show all cut and fill slopes, indicating top and bottom of slope catch lines
- \_\_\_\_\_ h. Show locations where upstream runoff enters the site and locations where runoff leaves the site.
- \_\_\_\_\_ i. Indicate existing surface water flow direction(s).
- \_\_\_\_\_ j. Label final grade contours and indicate proposed surface water flow direction and surface water conveyance systems (e.g. pipes, catch basins, ditches, etc.).
- \_\_\_\_\_ k. Show grades, dimensions, and direction of flow in all (existing and proposed) ditches, swales, culverts, and pipes.
- \_\_\_\_\_ l. Indicate locations and outlets of any dewatering systems (usually to sediment trap).
- \_\_\_\_\_ m. Identify and locate all erosion control techniques to be used during and after construction.
- \_\_\_\_\_ n. Finish floor elevations of all structures.

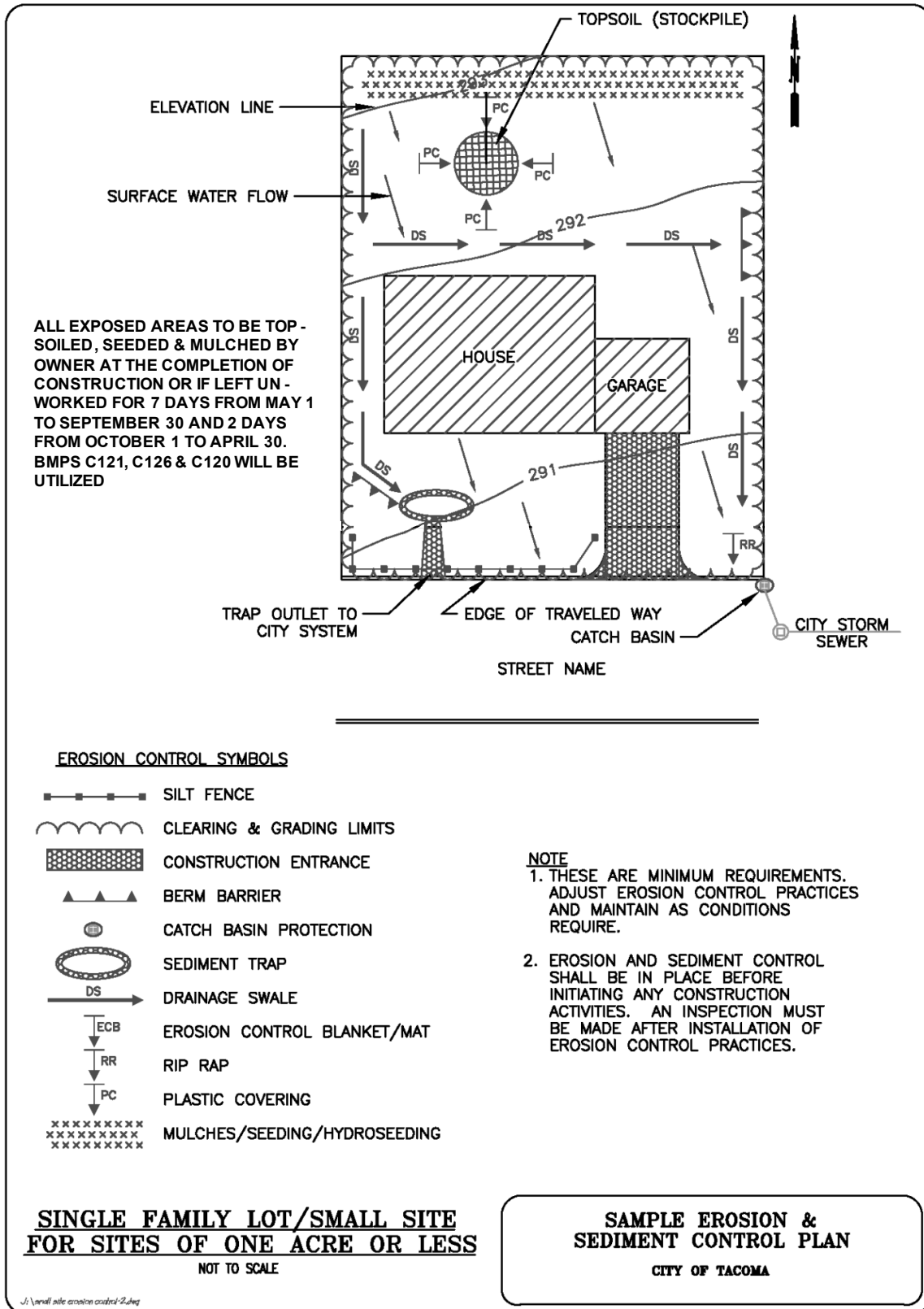


Figure 2 - 35. Sample Erosion and Sediment Control Plan

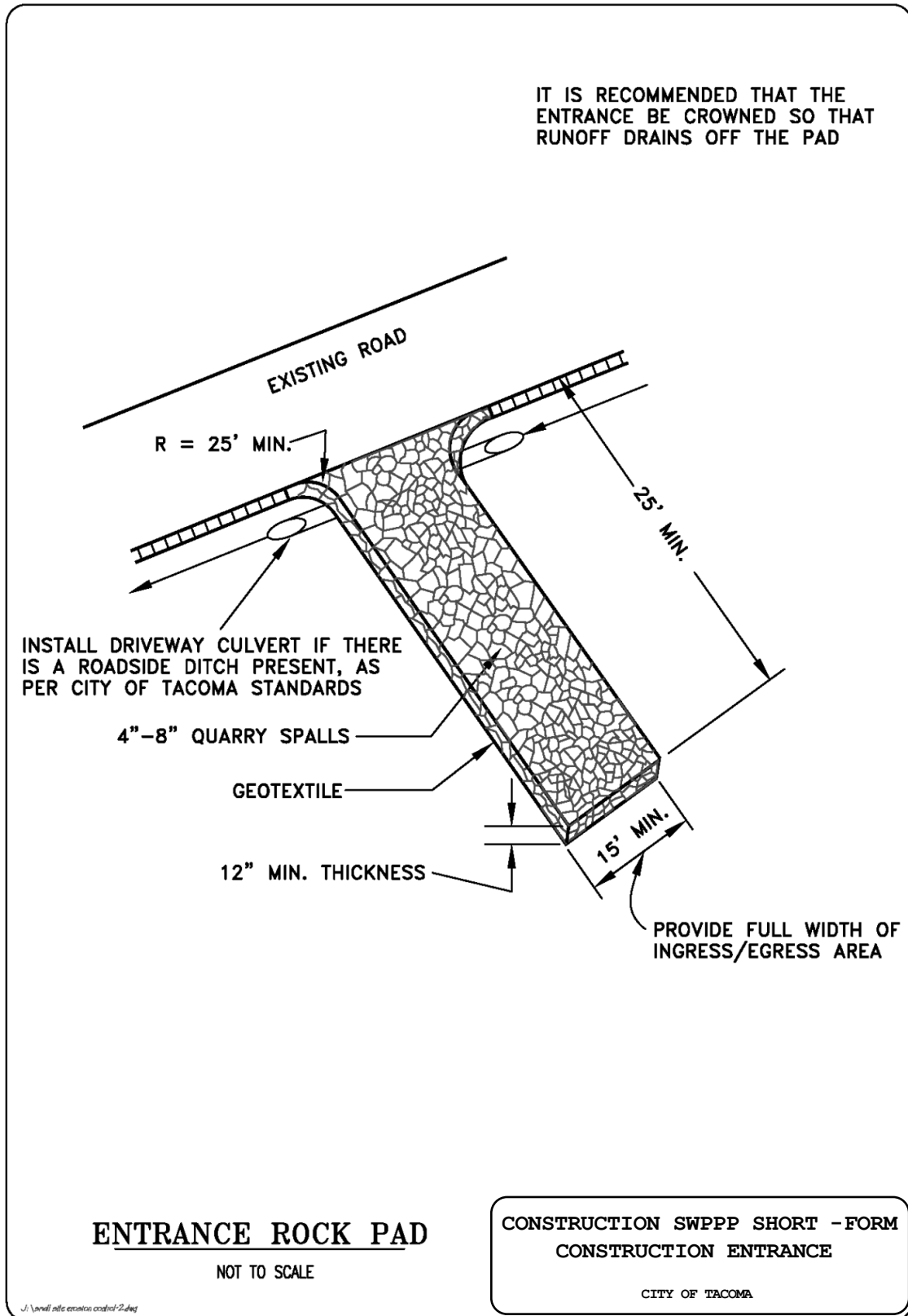


Figure 2 - 36. Construction Entrance

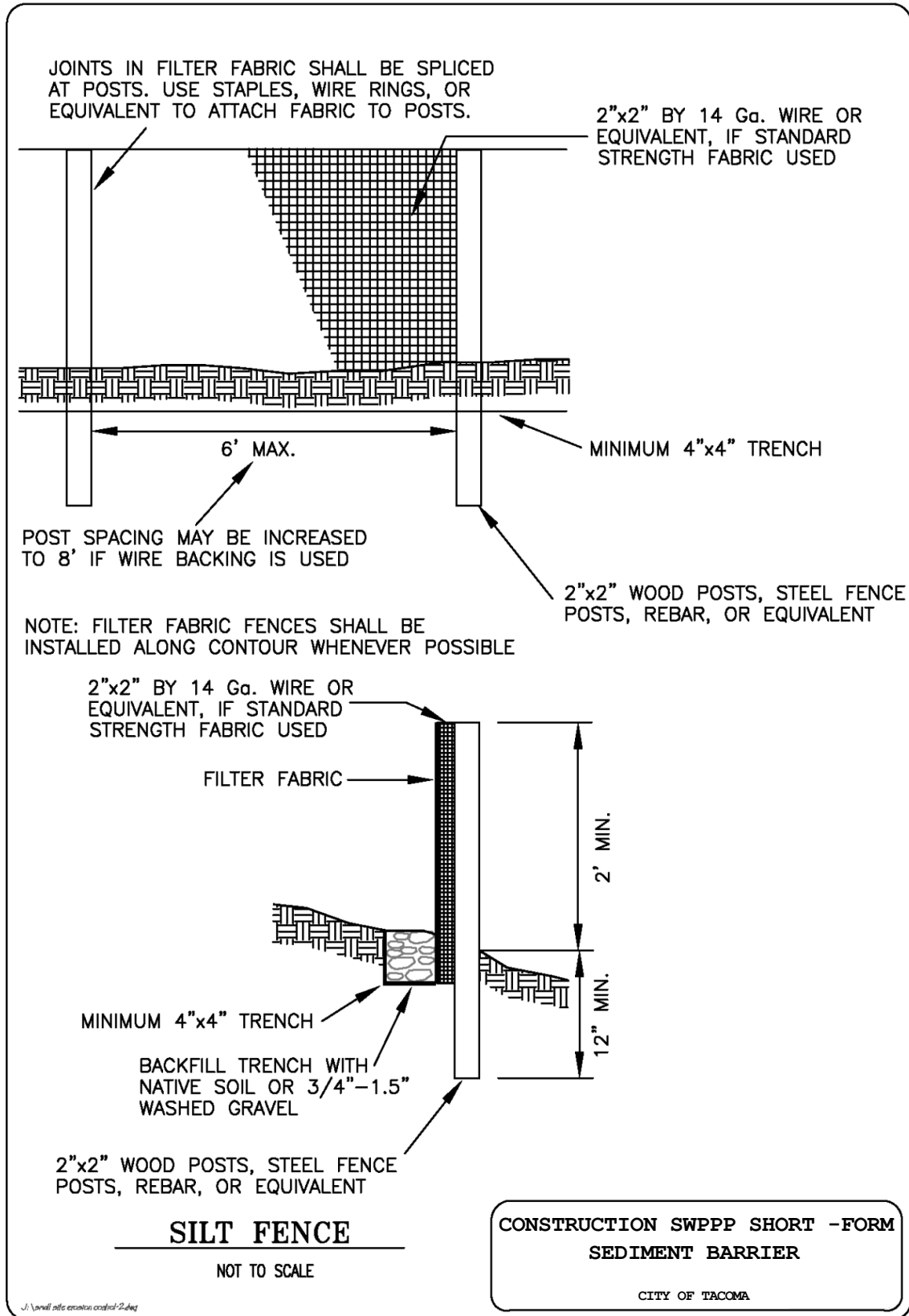
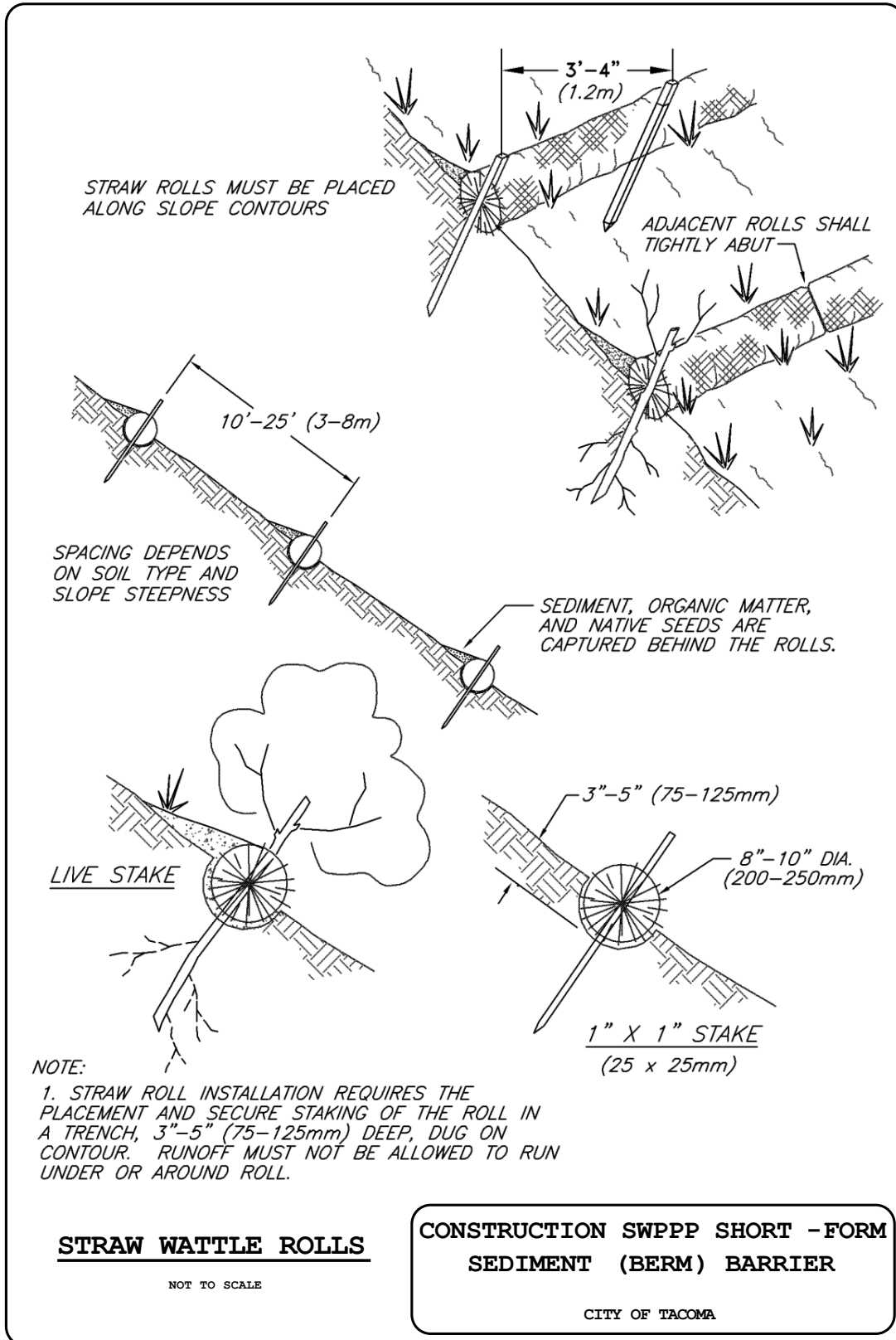


Figure 2 - 37. Sediment Barrier – Silt Fence



**Figure 2 - 38. Sediment (Berm) Barrier – Straw Wattle Rolls**



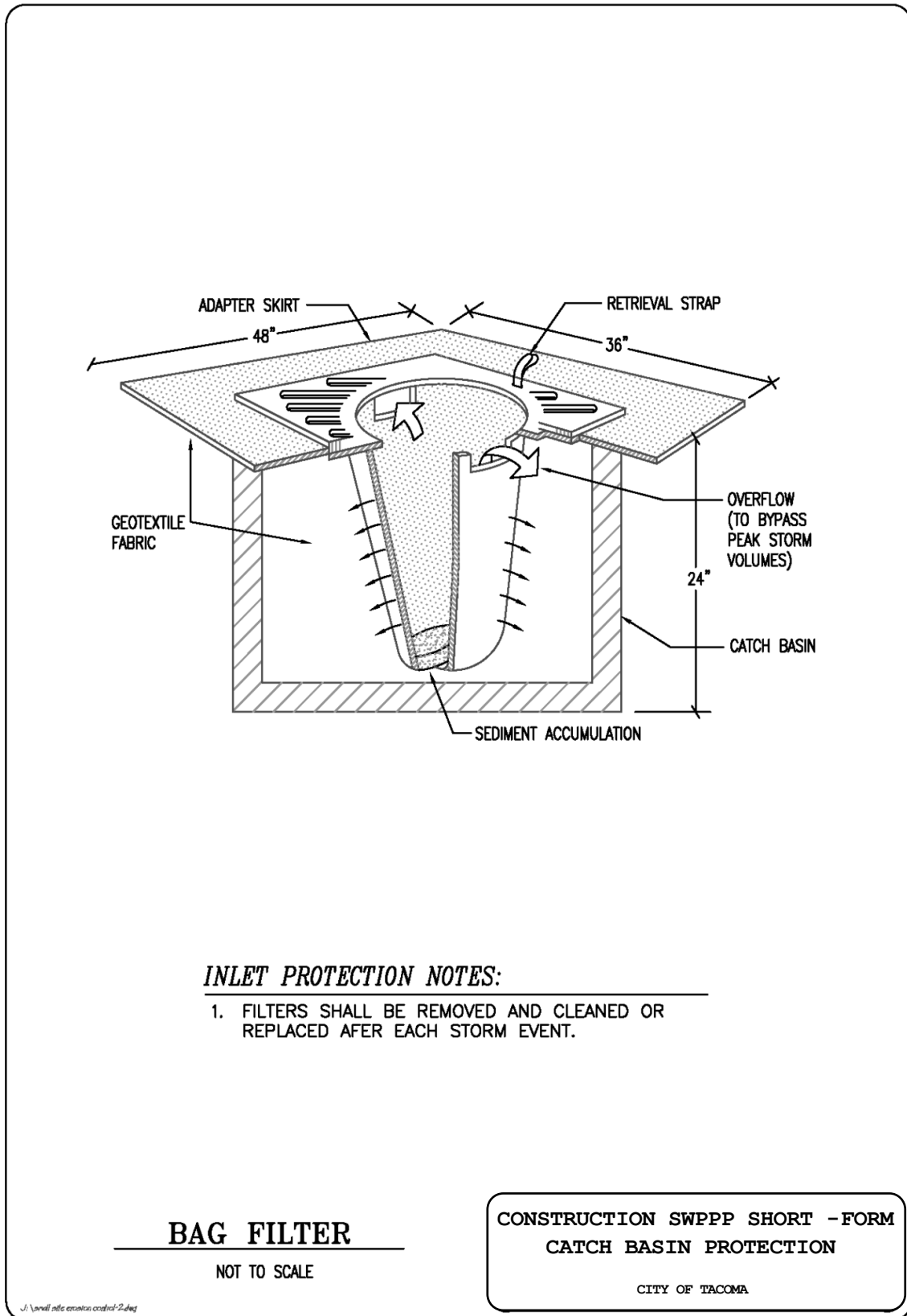


Figure 2 - 39. Catch Basin Protection – Bag Filter

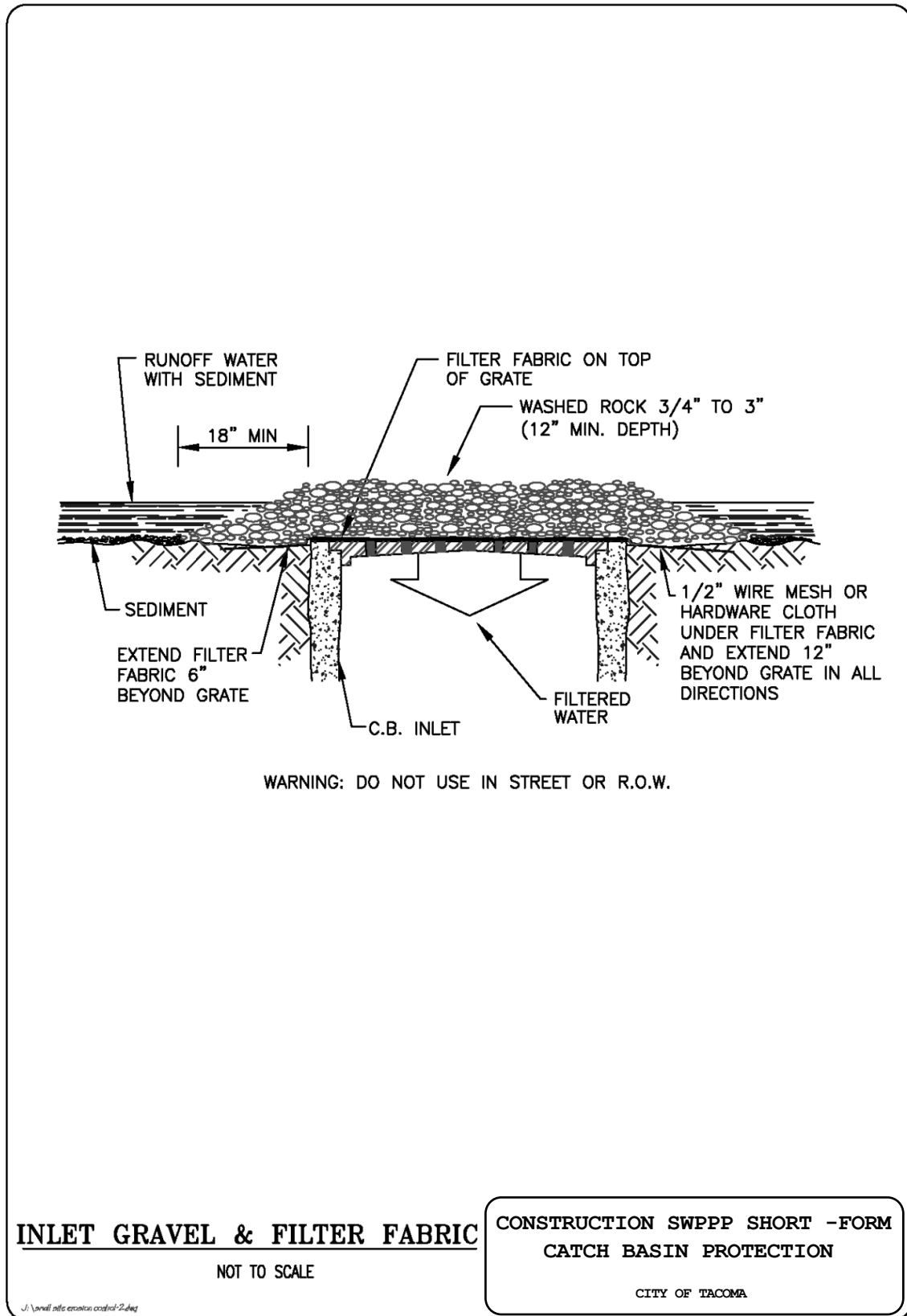
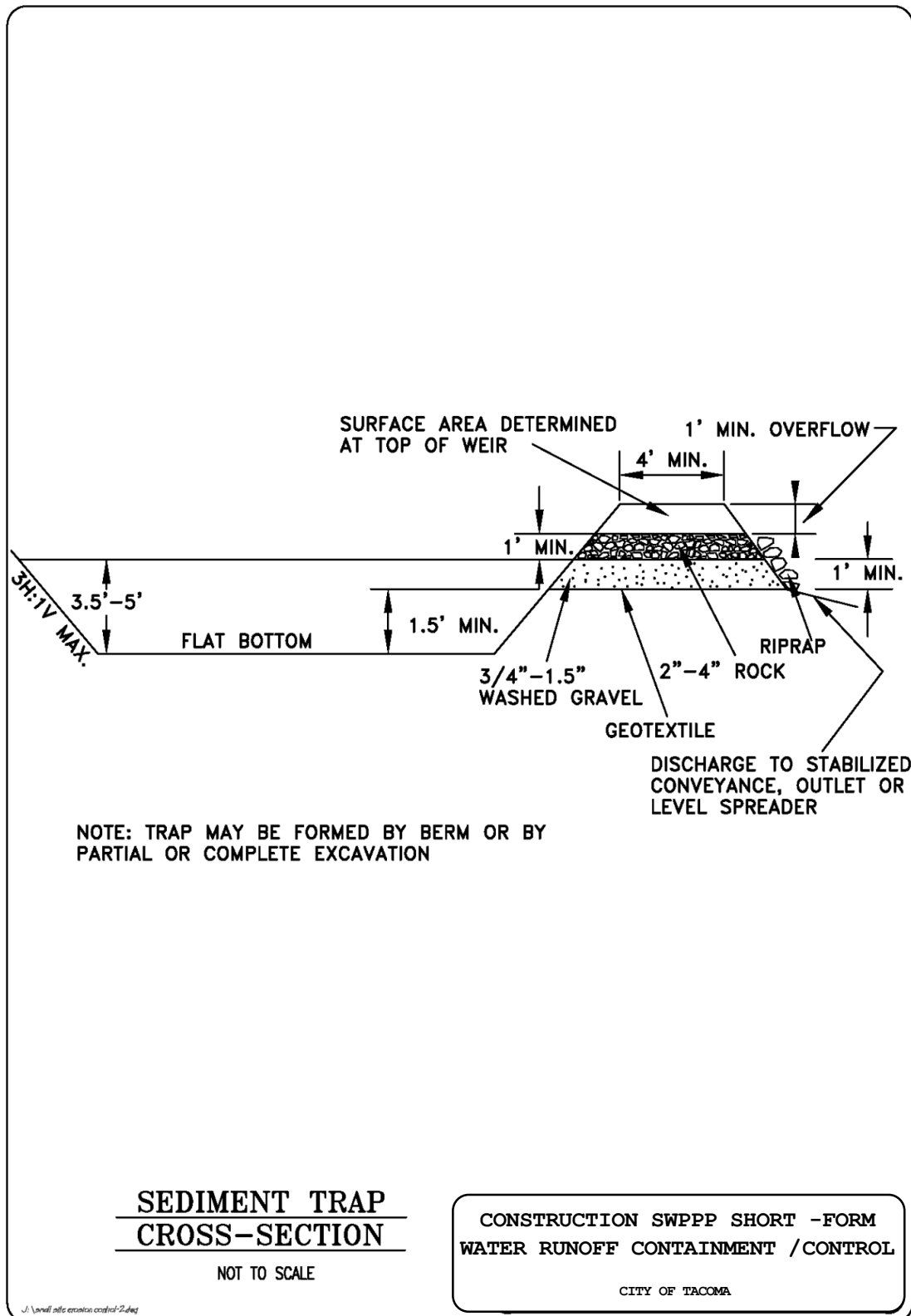


Figure 2 - 40. Catch Basin Protection – Inlet Gravel and Filter Fabric



**Figure 2 - 41. Water Runoff Containment/Control – Sediment Trap Cross-Section**

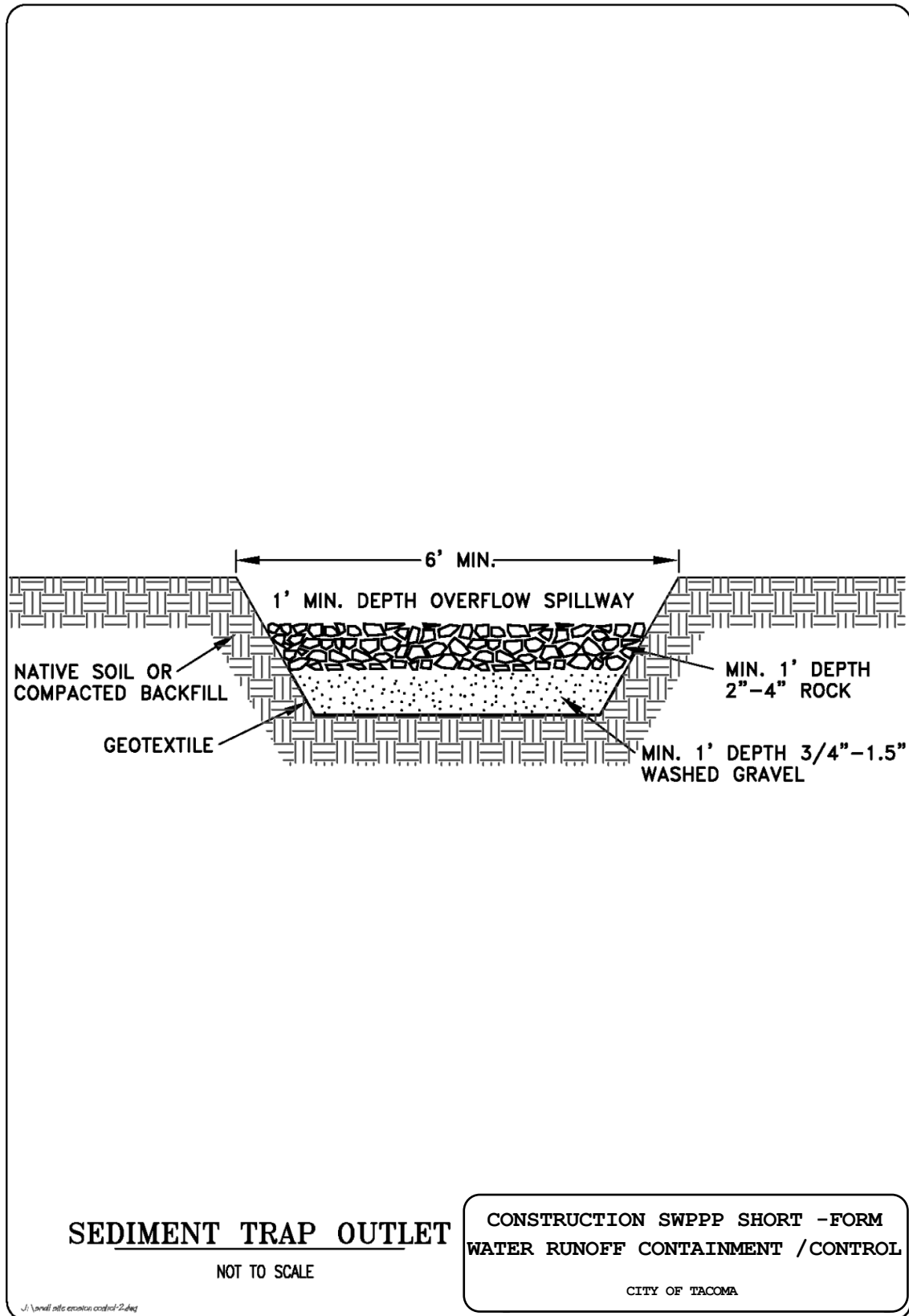


Figure 2 - 42. Water Runoff Containment/Control – Sediment Trap Outlet

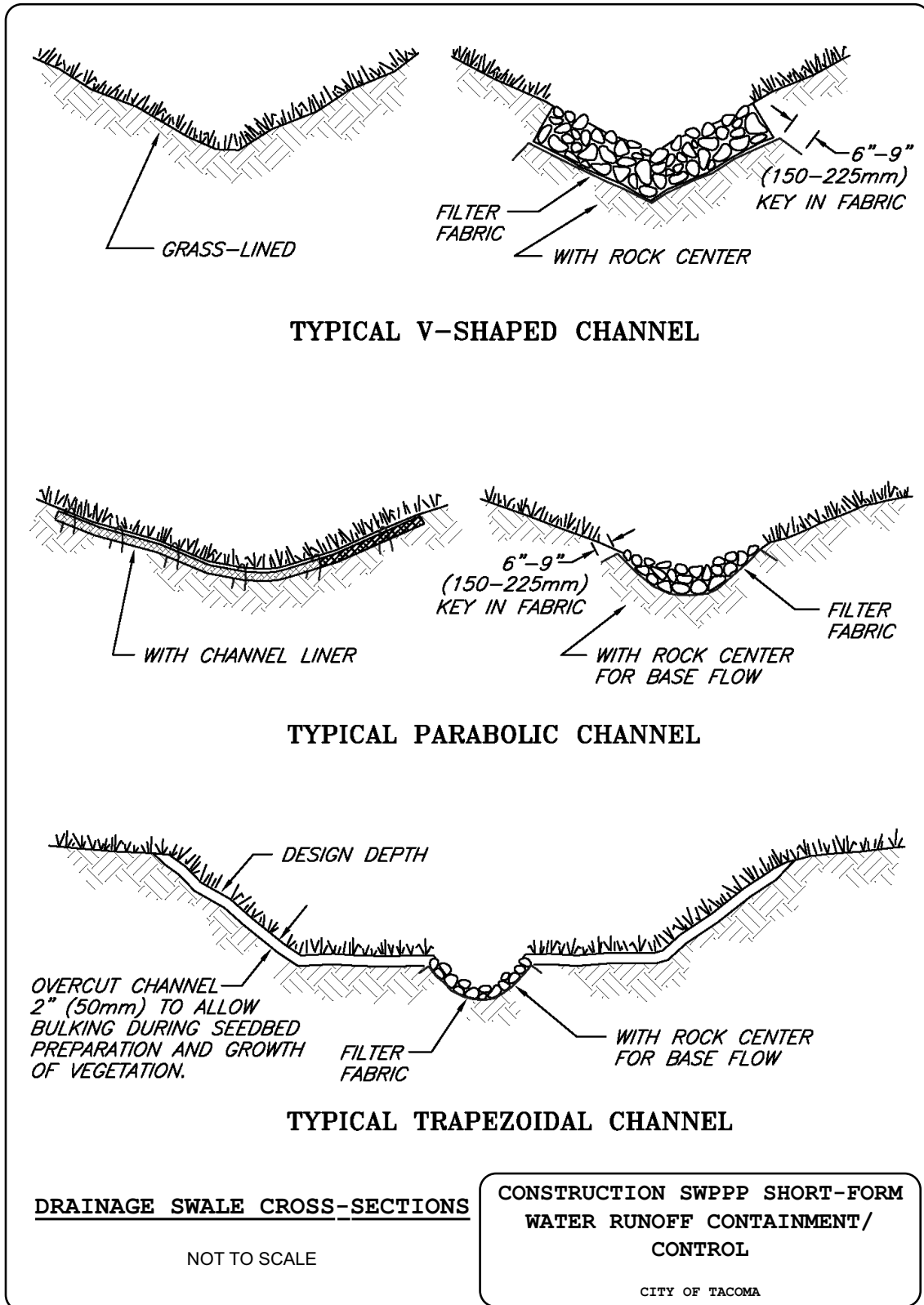


Figure 2 - 43. Water Runoff Containment/Control – Drainage Swale Cross-Sections

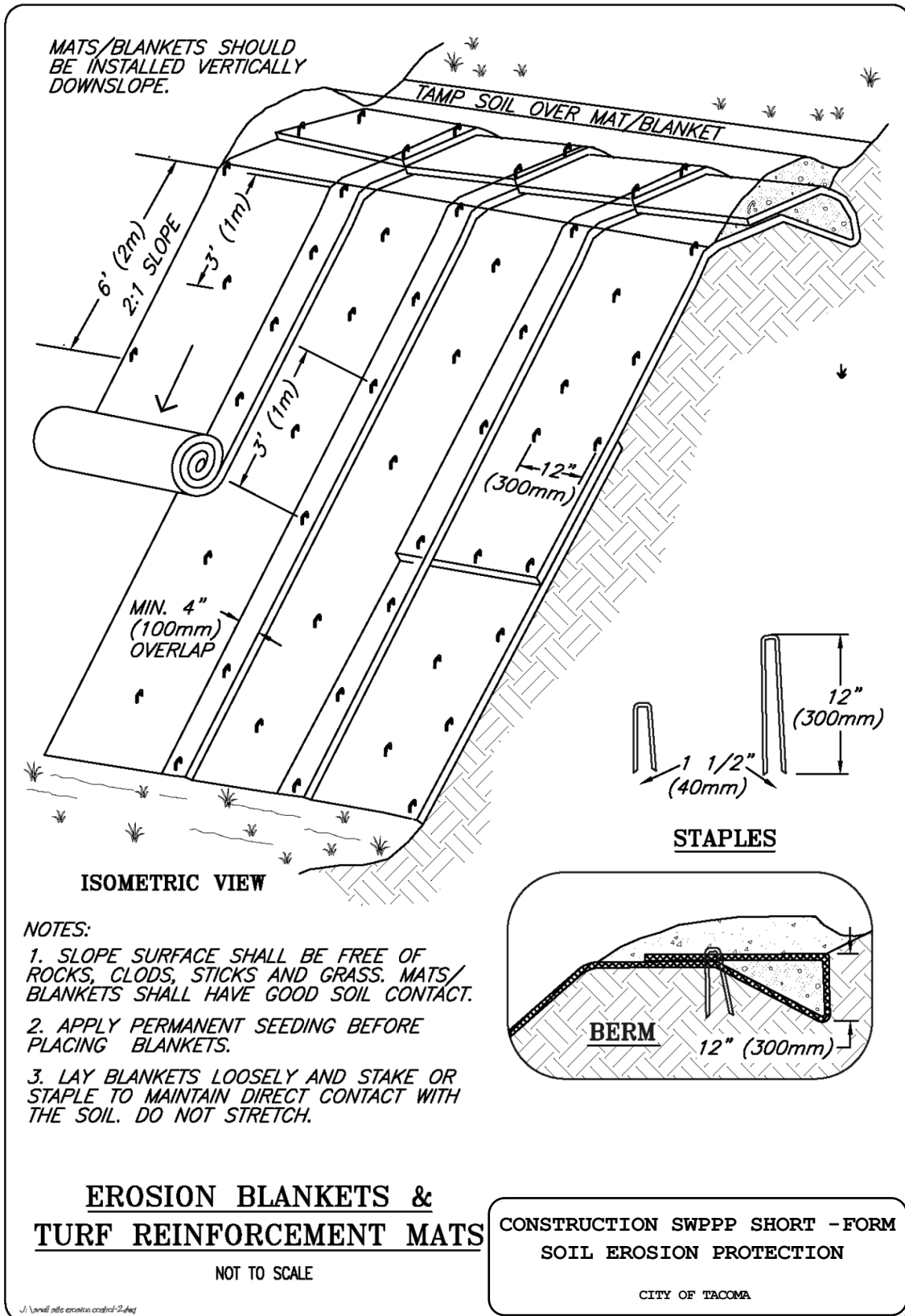
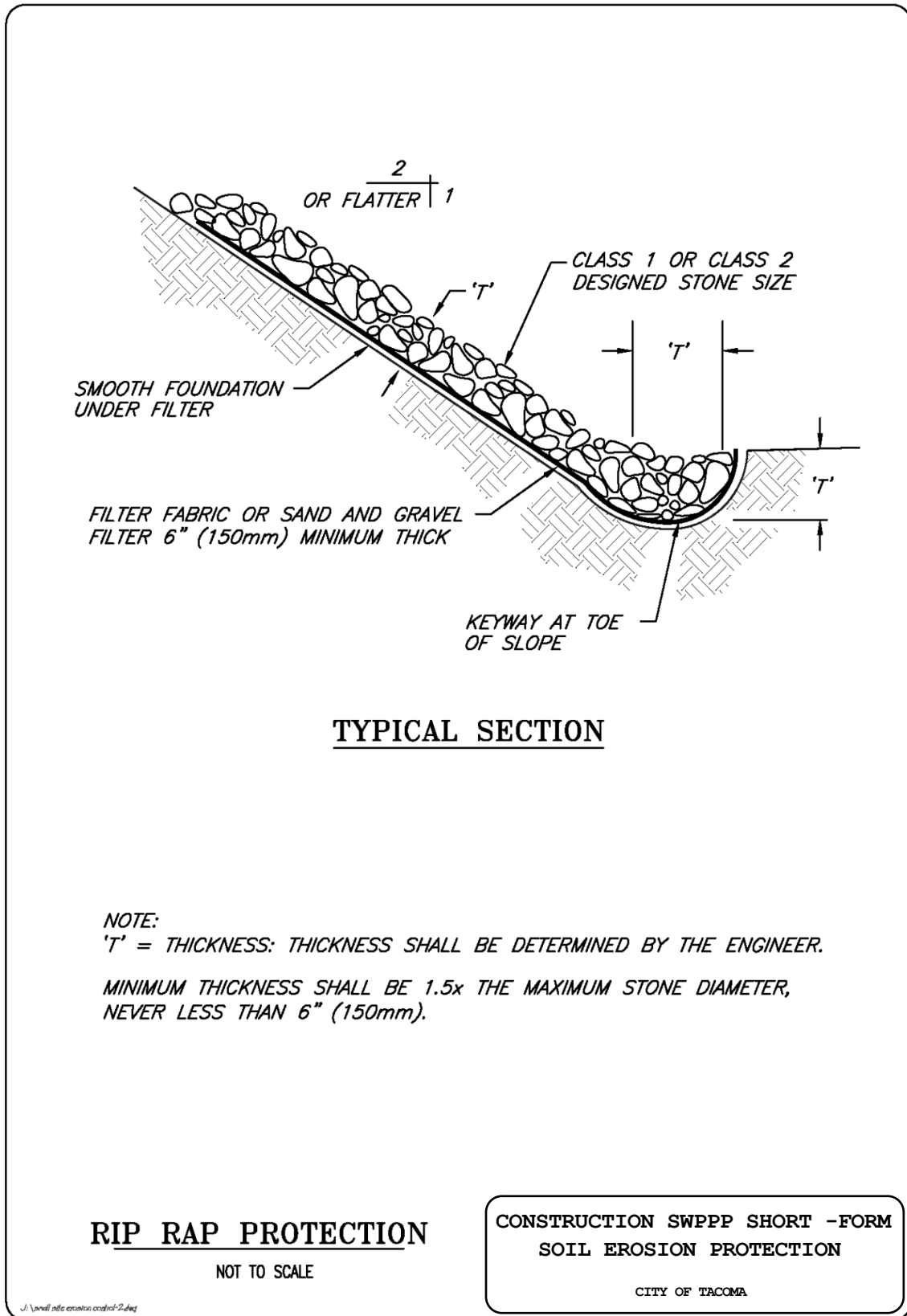


Figure 2 - 44. Soil Erosion Protection – Erosion Blankets and Turf Reinforcement Mats



**Figure 2 - 45. Soil Erosion Protection – Rip Rap Protection**

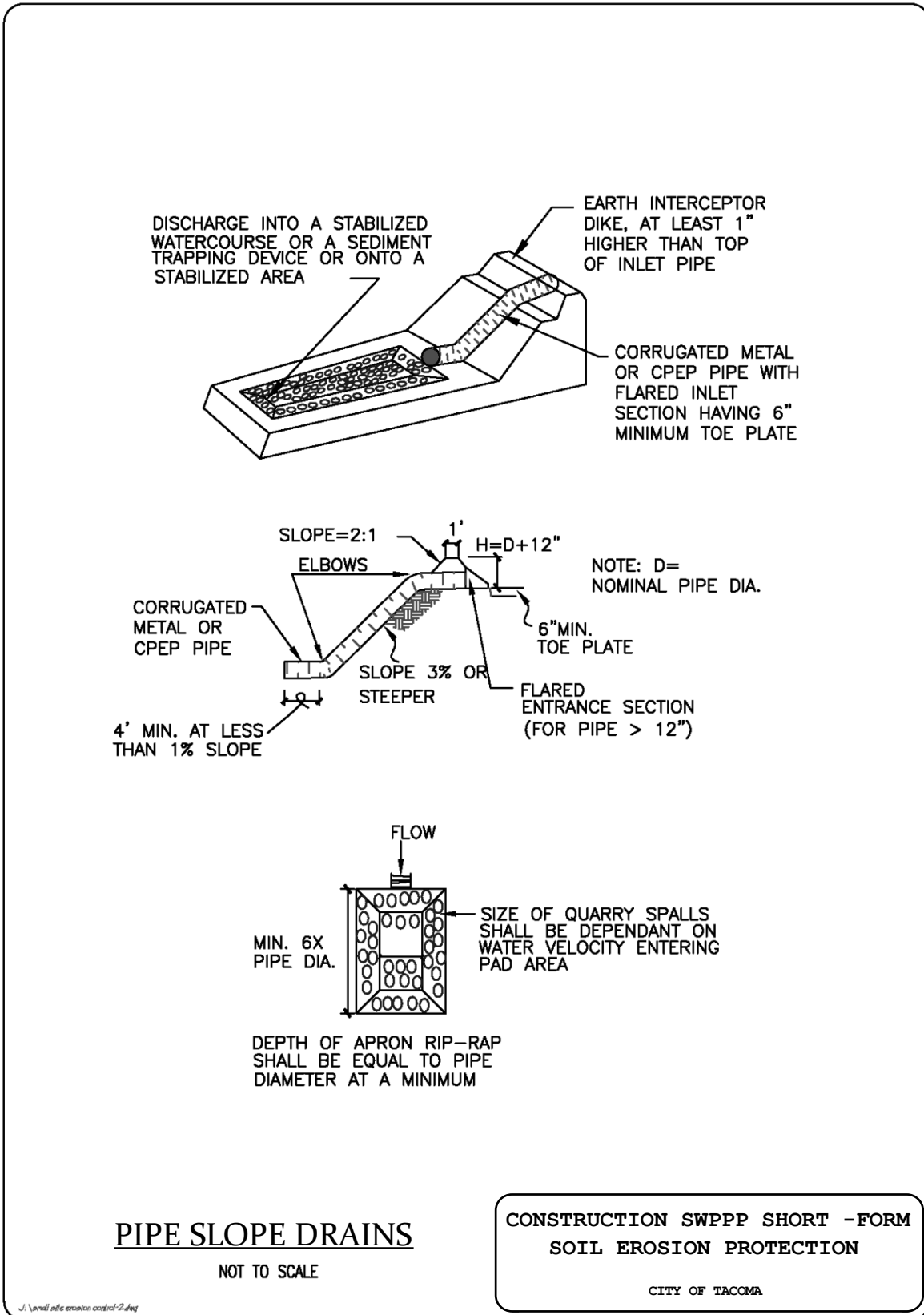


Figure 2 - 46. Soil Erosion Protection – Pipe Slope Drains



**This Page Intentionally Left Blank**

# Volume 3 - Onsite Stormwater Management, Flow Control & Conveyance

Purpose of this Volume . . . . .	3-1
Content and Organization of this Volume . . . . .	3-1
<b>Chapter 1 Hydrologic Analysis . . . . .</b>	<b>3-3</b>
1.1 Minimum Computational Standards . . . . .	3-3
1.2 Western Washington Hydrology Model . . . . .	3-3
1.3 Single-Event Hydrograph Method . . . . .	3-3
1.3.1 Design Storm . . . . .	3-3
1.3.2 Curve Number . . . . .	3-4
1.4 Closed Depression Analysis . . . . .	3-5
1.5 Bypass and Offsite Inflow - Considerations for Flow Control Facilities . . . . .	3-5
1.5.1 Bypass . . . . .	3-5
1.5.2 Offsite Inflow . . . . .	3-5
1.6 Rounding . . . . .	3-6
<b>Chapter 2 Roof Downspout Controls . . . . .</b>	<b>3-9</b>
2.1 Description . . . . .	3-9
2.2 Selection of Roof Downspout Controls . . . . .	3-9
2.3 Roof Downspout Infiltration . . . . .	3-9
2.3.1 Downspout Infiltration Soils Report Requirements . . . . .	3-9
2.3.2 BMP L601: Rain Gardens . . . . .	3-9
2.3.3 BMP L602 Downspout Full Infiltration BMPs . . . . .	3-10
2.3.3.1 Flow Credit for Roof Downspout Full Infiltration . . . . .	3-10
2.3.3.2 Roof Downspout Infiltration Setbacks and Site Controls . . . . .	3-10
2.3.3.3 Infeasibility Criteria for Downspout Full Infiltration Systems . . . . .	3-10
2.3.3.4 BMP L602.a: Infiltration Trenches . . . . .	3-11
2.3.3.5 BMP L602.b: Drywells . . . . .	3-13
2.3.3.6 Maintenance Criteria . . . . .	3-13
2.4 BMP L603 Downspout Dispersion Systems . . . . .	3-16
2.4.1 Application . . . . .	3-16
2.4.2 Flow Credit for Roof Downspout Dispersion . . . . .	3-16
2.4.3 Roof Downspout Dispersion Setbacks and Site Controls . . . . .	3-17
2.4.4 Infeasibility Criteria for Roof Downspout Dispersion . . . . .	3-17
2.4.5 General Design Criteria for Roof Downspout Dispersion . . . . .	3-18
2.4.6 Maintenance Criteria . . . . .	3-19
2.5 BMP L604: Perforated Stub-Out Connections . . . . .	3-23
2.5.1 Application . . . . .	3-23
2.5.2 Infeasibility Criteria for Perforated Stub-Out Connections . . . . .	3-24
2.5.3 Design Criteria . . . . .	3-24
2.5.4 Flow Credit for Perforated Stubouts . . . . .	3-25
2.5.5 Maintenance Criteria . . . . .	3-25
2.6 BMP L605 Collect and Convey . . . . .	3-25
<b>Chapter 3 Dispersion BMPs . . . . .</b>	<b>3-27</b>
3.1 BMP L611 Concentrated Flow Dispersion . . . . .	3-27

3.1.1 Purpose and Definition . . . . .	3-27
3.1.2 Applications and Limitations . . . . .	3-27
3.1.3 Infeasibility Criteria for Concentrated Flow Dispersion . . . . .	3-27
3.1.4 Design Criteria . . . . .	3-27
3.1.5 Setback Criteria . . . . .	3-27
3.1.6 Flow Credits for Concentrated Flow Dispersion . . . . .	3-28
3.1.7 Maintenance: . . . . .	3-28
3.2 BMP L612 Sheet Flow Dispersion . . . . .	3-29
3.2.1 Purpose and Definition . . . . .	3-29
3.2.2 Applications and Limitations . . . . .	3-29
3.2.3 Infeasibility Criteria for Sheet Flow Dispersion . . . . .	3-29
3.2.4 Design Criteria . . . . .	3-29
3.2.5 Setback Criteria . . . . .	3-30
3.2.6 Flow Credits for Sheet Flow Dispersion . . . . .	3-30
3.2.7 Maintenance Criteria . . . . .	3-30
3.3 BMP L614 Full Dispersion . . . . .	3-31
3.3.1 Purpose and Definition . . . . .	3-31
3.3.2 Applications and Limitations . . . . .	3-31
3.3.3 Design Guidelines for Residential Projects . . . . .	3-32
3.3.4 Setback Criteria . . . . .	3-34
3.3.5 Cleared Area Dispersion BMPs . . . . .	3-34
3.3.6 Design Guidelines for Road-Related Projects . . . . .	3-34
3.3.6.1 Uncollected or Natural Dispersion into Adjacent Vegetated Areas . . . . .	3-34
3.3.6.2 Channelized Dispersion . . . . .	3-35
3.3.6.3 Engineered Dispersion . . . . .	3-36
3.3.7 Native Vegetation Landscape Specifications . . . . .	3-37
3.3.8 Flow Credits for Full Dispersion . . . . .	3-38
<b>Chapter 4 Soil Quality BMPs . . . . .</b>	<b>3-39</b>
4.1 BMP L613 Post-Construction Soil Quality and Depth . . . . .	3-39
4.1.1 Purpose and Definition . . . . .	3-39
4.1.2 Applications and Limitations . . . . .	3-39
4.1.3 Infeasibility Criteria for Soil Quality BMPs . . . . .	3-39
4.1.4 Design Criteria . . . . .	3-39
4.1.5 Implementation Options: . . . . .	3-41
4.1.6 Maintenance . . . . .	3-46
4.1.7 Flow Reduction Credits for BMP L613 . . . . .	3-46
<b>Chapter 5 BMP L615 Tree Retention &amp; Transplanting . . . . .</b>	<b>3-47</b>
5.1 Applications and Limitations . . . . .	3-47
5.2 Retained Trees . . . . .	3-47
5.2.1 Site Considerations . . . . .	3-47
5.2.2 Design Criteria . . . . .	3-47
5.2.2.1 Certified Arborist Report . . . . .	3-47
5.2.2.2 Tree Species and Condition . . . . .	3-47
5.2.2.3 Tree Size . . . . .	3-48
5.2.2.4 Tree Location . . . . .	3-49
5.2.2.5 Tree Protection Measures during Construction . . . . .	3-49
5.2.2.6 Long-term Tree Retention and Protection . . . . .	3-49

- 5.2.3 Flow Control Credit . . . . . 3-50
- 5.3 Newly Transplanted Trees . . . . . 3-50
  - 5.3.1 Site Considerations . . . . . 3-50
  - 5.3.2 Design Criteria . . . . . 3-50
    - 5.3.2.1 Tree Species . . . . . 3-51
    - 5.3.2.2 Tree Size . . . . . 3-51
    - 5.3.2.3 Tree Location . . . . . 3-51
    - 5.3.2.4 Irrigation . . . . . 3-51
    - 5.3.2.5 Long-term Tree Retention and Protection . . . . . 3-51
  - 5.3.3 Flow Control Credit . . . . . 3-51
- 5.4 Operations and Maintenance Requirements. . . . . 3-52
- Chapter 6 Infiltration Facilities for Stormwater Flow Control . . . . . 3-53**
- 6.1 Purpose. . . . . 3-53
- 6.2 Description . . . . . 3-53
- 6.3 Design Methodology . . . . . 3-55
  - 6.3.1 Select a location . . . . . 3-55
  - 6.3.2 Estimate volume of stormwater, Vdesign . . . . . 3-55
  - 6.3.3 Develop trial infiltration facility geometry . . . . . 3-55
  - 6.3.4 Complete a more detailed site characterization study and consider site suitability criteria . . . . . 3-55
  - 6.3.5 Determine the infiltration rate . . . . . 3-55
  - 6.3.6 Size the facility. . . . . 3-55
    - 6.3.6.1 Drawdown Time . . . . . 3-56
  - 6.3.7 Construction Criteria . . . . . 3-56
  - 6.3.8 Maintenance Criteria . . . . . 3-57
  - 6.3.9 Verification Testing of the Completed Facility . . . . . 3-57
- 6.4 Site Characterization Criteria . . . . . 3-57
  - 6.4.1 Surface Features Characterization . . . . . 3-57
  - 6.4.2 Subsurface Characterization . . . . . 3-57
  - 6.4.3 Infiltration Rate Determination . . . . . 3-58
  - 6.4.4 Infiltration Receptor . . . . . 3-58
- 6.5 Design Saturated Hydraulic Conductivity – Guidelines and Criteria . . . . . 3-59
  - 6.5.1 Large Scale Pilot Infiltration Test (PIT) . . . . . 3-59
    - 6.5.1.1 Large Scale Pilot Infiltration Test Procedure . . . . . 3-60
    - 6.5.1.2 Large Scale PIT Data Analysis . . . . . 3-60
  - 6.5.2 Small Scale Pilot Infiltration Test (PIT) . . . . . 3-61
    - 6.5.2.1 Small Scale Pilot Infiltration Test Procedure . . . . . 3-61
    - 6.5.2.2 Small Scale PIT Data Analysis. . . . . 3-62
  - 6.5.3 Soil Grain Size Analysis Method . . . . . 3-62
  - 6.5.4 Correction Factors . . . . . 3-64
    - 6.5.4.1 Site variability and number of locations tested (CFv). . . . . 3-64
    - 6.5.4.2 Uncertainty of Test Method (CFt). . . . . 3-65
    - 6.5.4.3 Siltation and Biofouling (CFm). . . . . 3-65
- 6.6 Site Suitability Criteria. . . . . 3-66
  - 6.6.1 Setback Criteria. . . . . 3-66
  - 6.6.2 Groundwater Protection Areas . . . . . 3-66
  - 6.6.3 High Vehicle Traffic Areas . . . . . 3-66
  - 6.6.4 Depth to Bedrock, Water Table, or Impermeable Layer . . . . . 3-67

6.6.5 Seepage Analysis and Control . . . . .	3-67
6.6.6 Cold Climate and Impact of Roadway Deicers . . . . .	3-67
6.7 Design Criteria for Infiltration Facilities . . . . .	3-67
6.7.1 Infiltration Facility Setbacks . . . . .	3-67
6.7.2 Pretreatment . . . . .	3-68
6.7.3 Infiltration Facility Access . . . . .	3-68
6.7.4 Infiltration Facility Overflow . . . . .	3-69
6.7.5 Infiltration Facility Seeps and Springs . . . . .	3-69
6.7.6 Infiltration Facility Construction Criteria . . . . .	3-69
6.7.7 Infiltration Facility Maintenance . . . . .	3-69
6.7.8 Infiltration Facility Easements . . . . .	3-69
6.8 Infiltration Basins . . . . .	3-69
6.8.1 Description . . . . .	3-70
6.8.2 Design Criteria Specific for Basins . . . . .	3-70
6.9 Infiltration Trenches . . . . .	3-70
6.9.1 Description . . . . .	3-70
6.9.2 Design Criteria . . . . .	3-70
6.9.2.1 Cleanouts/Access Ports . . . . .	3-71
6.9.2.2 Backfill Material . . . . .	3-71
6.9.2.3 Geotextile Fabric Liner . . . . .	3-71
6.9.2.4 Overflow Channel . . . . .	3-71
6.9.2.5 Surface Cover . . . . .	3-71
6.9.2.6 Observation Well . . . . .	3-71
6.9.2.7 Pipe . . . . .	3-71
6.9.3 Construction Criteria . . . . .	3-72
6.9.3.1 Trench Preparation . . . . .	3-72
6.9.3.2 Stone Aggregate Placement and Compaction . . . . .	3-72
6.9.3.3 Potential Contamination . . . . .	3-72
6.9.3.4 Overlapping and Covering . . . . .	3-72
6.9.3.5 Voids behind Geotextile . . . . .	3-72
6.9.3.6 Unstable Excavation Sites . . . . .	3-72
<b>Chapter 7 Detention Facilities for Stormwater Flow Control . . . . .</b>	<b>3-73</b>
7.1 Detention Facility Design Criteria . . . . .	3-73
7.1.1 Detention Facility Setbacks . . . . .	3-73
7.1.2 Detention Facility Access . . . . .	3-74
7.1.3 Detention Facility Overflow . . . . .	3-74
7.1.4 Detention Facility Seeps and Springs . . . . .	3-74
7.1.5 Detention Facility Maintenance . . . . .	3-74
7.1.6 Detention Facility Easements . . . . .	3-75
7.2 Detention Ponds . . . . .	3-75
7.2.1 Dam Safety for Detention Ponds . . . . .	3-75
7.2.2 Design Criteria Specific for Detention Ponds . . . . .	3-75
7.2.2.1 General . . . . .	3-75
7.2.2.2 Setbacks . . . . .	3-75
7.2.2.3 Side Slopes . . . . .	3-76
7.2.2.4 Embankments . . . . .	3-76
7.2.2.5 Overflow . . . . .	3-79
7.2.2.6 Emergency Overflow Spillway . . . . .	3-80
7.2.2.7 Access . . . . .	3-80

- 7.2.2.8 Fencing ..... 3-81
- 7.2.2.9 Signage ..... 3-81
- 7.2.2.10 Planting Requirements ..... 3-83
- 7.2.2.11 Landscaping ..... 3-83
- 7.2.3 Methods of Analysis ..... 3-84
  - 7.2.3.1 Detention Volume and Outflow ..... 3-84
  - 7.2.3.2 Detention Ponds in Infiltrative Soils ..... 3-85
  - 7.2.3.3 Emergency Overflow Spillway Capacity ..... 3-85
- 7.3 Detention Tanks ..... 3-86
  - 7.3.1 Design Criteria ..... 3-88
    - 7.3.1.1 General ..... 3-88
    - 7.3.1.2 Materials ..... 3-88
    - 7.3.1.3 Structural Stability ..... 3-88
    - 7.3.1.4 Buoyancy ..... 3-88
    - 7.3.1.5 Access ..... 3-88
    - 7.3.1.6 Methods of Analysis ..... 3-89
- 7.4 Detention Vaults ..... 3-89
  - 7.4.1 Design Criteria ..... 3-91
    - 7.4.1.1 General ..... 3-91
    - 7.4.1.2 Materials ..... 3-91
    - 7.4.1.3 Structural Stability ..... 3-91
    - 7.4.1.4 Access ..... 3-91
  - 7.4.2 Methods of Analysis ..... 3-92
    - 7.4.2.1 Detention Volume and Outflow ..... 3-92
- 7.5 Control Structures ..... 3-92
  - 7.5.1 Design Criteria ..... 3-92
    - 7.5.1.1 Multiple Orifice Restrictor ..... 3-92
    - 7.5.1.2 Riser and Weir Restrictor ..... 3-93
    - 7.5.1.3 Access ..... 3-93
    - 7.5.1.4 Materials ..... 3-93
    - 7.5.1.5 Maintenance ..... 3-93
  - 7.5.2 Methods of Analysis ..... 3-94
    - 7.5.2.1 Orifices ..... 3-94
    - 7.5.2.2 Rectangular Sharp-Crested Weir ..... 3-94
    - 7.5.2.3 V-Notch Sharp - Crested Weir ..... 3-95
    - 7.5.2.4 Proportional or Sutro Weir ..... 3-95
    - 7.5.2.5 Riser Overflow ..... 3-95
- Chapter 8 Other Detention Options ..... 3-105**
  - 8.1 Use of Parking Lots for Additional Detention ..... 3-105
  - 8.2 Use of Roofs for Detention ..... 3-105
- Chapter 9 Conveyance System Design and Hydraulic Analysis ..... 3-107**
  - 9.1 Design Methods for Conveyance Systems ..... 3-107
  - 9.2 Methods of Analysis ..... 3-108
    - 9.2.1 Onsite Analysis ..... 3-108
    - 9.2.2 Offsite Analysis ..... 3-108
      - 9.2.2.1 Qualitative Downstream Analysis ..... 3-108
      - 9.2.2.2 Quantitative Downstream Analysis ..... 3-108
  - 9.3 Hydrologic Modeling ..... 3-109
    - 9.3.1 Computer Models for Conveyance Systems ..... 3-109
    - 9.3.2 Single Segment Capacity Analysis ..... 3-109

9.3.3 Full Backwater Analysis . . . . .	3-110
9.3.3.1 Full Backwater Analysis Design Criteria . . . . .	3-110
9.3.3.2 Pipe System Design Events . . . . .	3-110
9.3.3.3 Culvert Design Events . . . . .	3-111
9.3.3.4 Open Channel Design Events . . . . .	3-111
9.3.4 Rational Method . . . . .	3-112
9.3.4.1 Rational Method Equation . . . . .	3-112
9.3.5 Uniform Flow Analysis Design Events . . . . .	3-118
9.4 Inlet Grate Capacity . . . . .	3-119
9.4.1 Inlet Types . . . . .	3-120
9.4.1.1 Herringbone Pattern (WSDOT Standard Plan B-30.50) . . . . .	3-120
9.4.1.2 Vaned Grate (WSDOT Standard Plan B-30.30 or 30.40) . . . . .	3-120
9.4.1.3 Combination Inlets (WSDOT Standard Plan B-25.20) . . . . .	3-120
9.4.1.4 Grate Inlets Type 1 or 2 (WSDOT Standard Plans B-35.20, B-35.40, and B-40.20) . . . . .	3-120
9.4.1.5 Frame and Vaned Grates (WSDOT Standard Plan B-40.40) . . . . .	3-121
9.4.1.6 Circular Grates . . . . .	3-121
9.4.2 Capacity of Inlets on a Continuous Grade . . . . .	3-121
9.4.2.1 Inlet Analysis Spreadsheet . . . . .	3-122
9.4.3 Side Flow Interception . . . . .	3-124
9.4.3.1 Inlet Analysis Spreadsheet . . . . .	3-125
9.4.4 Capacity of Inlets in Sag Locations . . . . .	3-125
9.5 Gutter Capacity Analysis . . . . .	3-129
9.6 Basis of Design . . . . .	3-131
<b>Chapter 10 Material Specifications . . . . .</b>	<b>3-133</b>
10.1 Pipe Specifications . . . . .	3-133
10.1.1 Pipe Materials . . . . .	3-133
10.1.1.1 Pipes Within Right-of-Way . . . . .	3-133
10.1.1.2 Private Pipes Outside the Right-of-Way . . . . .	3-134
10.1.2 Pipe Sizes . . . . .	3-135
10.1.3 Changes in Pipe Sizes . . . . .	3-135
10.1.4 Pipe Alignment and Depth . . . . .	3-135
10.1.5 Pipe Slopes and Velocities . . . . .	3-136
10.1.6 Pipes on Steep Slopes . . . . .	3-136
10.1.7 Pipe Clearances . . . . .	3-137
10.1.7.1 Horizontal Clearance . . . . .	3-137
10.1.7.2 Vertical Clearance . . . . .	3-138
10.1.8 Pipe Cover . . . . .	3-138
10.2 Culvert Specifications . . . . .	3-138
10.2.1 Inlets and Outlets . . . . .	3-139
10.3 Open Channel Specifications . . . . .	3-139
10.3.1 Natural Channels . . . . .	3-139
10.3.2 Constructed Channels . . . . .	3-139
10.3.3 Open Channel Design Criteria . . . . .	3-140
10.4 Structures . . . . .	3-141
10.5 System Connections . . . . .	3-144
10.6 Debris Barriers . . . . .	3-146
10.7 Riprap Design . . . . .	3-147

**Chapter 11 Outfall Systems . . . . . 3-153**

    11.1 Outfall Design Criteria . . . . . 3-153

        11.1.1 Energy dissipation . . . . . 3-154

        11.1.2 Flow dispersion . . . . . 3-154

    11.2 Tightline Systems . . . . . 3-160

    11.3 Habitat Considerations . . . . . 3-161

**Chapter 12 Pump Systems . . . . . 3-163**

    12.1 Design Criteria . . . . . 3-163

    12.2 Pump Requirements . . . . . 3-163

    12.3 Additional Requirements . . . . . 3-163

        12.3.1 Submittal Requirements . . . . . 3-164

    12.4 Sump Pumps . . . . . 3-165

**Chapter 13 Easements, Access, and Dedicated Tracts . . . . . 3-167**

    13.1 Stormwater Facilities . . . . . 3-167

        13.1.1 Public . . . . . 3-167

        13.1.2 Private . . . . . 3-167

    13.2 Conveyance Systems . . . . . 3-167

        13.2.1 Public . . . . . 3-167

        13.2.2 Private . . . . . 3-168

    13.3 Maintenance Access . . . . . 3-169

**Appendix A Tacoma Design Storm . . . . . 3-171**

**Appendix B Soils Reports . . . . . 3-173**







# Onsite Stormwater Management, Flow Control & Conveyance

## Purpose of this Volume

The purpose of this volume is to outline methods for managing stormwater onsite, designing flow control BMPs and designing conveyance systems. Guidance is provided for managing post-construction soils as well as tree retention and planting.

## Content and Organization of this Volume

Volume 3 of this manual contains thirteen chapters.

- Chapter 1 reviews methods of hydrologic analysis.
- Chapter 2 describes roof downspout controls.
- Chapter 3 describes dispersion BMPs.
- Chapter 4 describes post-construction soil quality and depth.
- Chapter 5 describes tree retention and planting.
- Chapter 6 provides guidance for infiltration facility design requirements for flow control.
- Chapter 7 provides guidance for detention facility design.
- Chapter 8 describes additional options for flow control.
- Chapter 9 provides guidance for conveyance system design.
- Chapter 10 describes material specifications.
- Chapter 11 provides guidance for outfall design.
- Chapter 12 provides guidance for pump systems.
- Chapter 13 describes easement and access requirements.

**This Page Intentionally Left Blank**

# Chapter 1 Hydrologic Analysis

The purpose of this chapter is to define the minimum computational standards required, and outline how these computational standards may be applied.

## 1.1 Minimum Computational Standards

The minimum computational standards depend on the type of information required and the size of the drainage area to be analyzed, as follows:

- WWHM shall be used for designing flow control and water quality treatment BMPs.

**NOTE:** Facilities that are sized based on a water quality volume may require design based on single event modeling.

- Other HSPF or continuous simulation models may be accepted on case-by-case basis at the discretion of the City.
- Model calibration shall be required for basins greater than 320 acres.
- Single event modeling shall be used to size conveyance systems and verify current system capacity. See Chapter 9 for more information.

## 1.2 Western Washington Hydrology Model

For most flow control design purposes, a continuous runoff model, such as the Western Washington Hydrology Model (WWHM), must be used. Information on the WWHM is provided in the Stormwater Management Manual for Western Washington (Washington State Department of Ecology, 2012). The software can be downloaded at the following website:

<http://www.ecy.wa.gov/programs/wq/stormwater/wwhmtraining/index.html>

More WWHM information is available at <http://www.clearcreeksolutions.com>

## 1.3 Single-Event Hydrograph Method

Single event methods are only acceptable for sizing wetpool treatment facilities or for conveyance analysis.

All storm event hydrograph methods require input of parameters that describe physical drainage basin characteristics. These parameters provide the basis from which the runoff hydrograph is developed. Guidance and requirements for some of these parameters is provided in the following sections.

### 1.3.1 Design Storm

The total depth of rainfall for storms of 24-hour duration and 2, 5, 10, 25, 50, and 100-year recurrence intervals are published by the National Oceanic and Atmospheric Administration (NOAA). The information is presented in the form of “isopluvial” maps for each state. Isopluvial maps are maps where the contours represent total inches of rainfall for a specific duration. Isopluvial maps for the 2, 5, 10, 25, 50, and 100-year recurrence interval and 24-hour duration storm events can be found in the NOAA Atlas 2, “Precipitation - Frequency Atlas of the Western United States, Volume IX-Washington.”

Based on these isopluvials, the following design storms assuming a Type 1A rainfall distribution shall be used for the City of Tacoma:

6-month, 24-hour design storm: 1.44 inches

2-year, 24-hour design storm: 2.0 inches

10-year, 24-hour design storm: 3.0 inches

25-year, 24-hour design storm: 3.5 inches

100-year, 24-hour design storm: 4.1 inches

### **1.3.2 Curve Number**

The NRCS did not map the soils within the City of Tacoma. For modeling purposes, soils within the City limits shall be assumed to fall in Hydrologic Soil Group C unless site-specific grain size distribution and/or permeability testing indicates otherwise. This assumption of soil type cannot be used to prove infeasibility for onsite infiltration, nor can it be used as a basis to design onsite infiltration facilities. Volume 3, Appendix B provides guidance for site specific soils analyses.

Table 3 - 1 shows the curve numbers (CNs), by land use description, for the four hydrologic soil groups. These numbers are for a 24-hour duration storm and the typical antecedent soil moisture condition preceding 24-hour storms.

The following are important criteria/considerations for selection of CN values.

Many factors may affect the CN value for a given land use. For example, the movement of heavy equipment over bare ground may compact the soil so that it has a lower infiltration rate and greater runoff potential than would be indicated by strict application of the CN value to developed site conditions.

CN values can be area weighted when they apply to pervious areas of similar CNs (within 20 CN points). However, high CN areas should not be combined with low CN areas. In this case, separate estimates of S (potential maximum natural detention) and Qd (runoff depth) should be generated and summed to obtain the cumulative runoff volume unless the low CN areas are less than 15 percent of the sub-basin.

Separate CN values must be selected for the pervious and impervious areas of an urban basin or sub-basin. The pervious area CN value must be a weighted average of all the pervious area CNs within the sub-basin. The impervious area CN value shall be 98.

## 1.4 Closed Depression Analysis

The analysis of closed depressions requires careful assessment of the existing hydrologic performance in order to evaluate the impacts of a proposed project. A calibrated continuous simulation hydrologic model must be used for closed depression analysis and design of mitigation facilities. The applicable requirements of this manual (see Minimum Requirement #7 and #8) and the City's Critical Areas Preservation Ordinance (CAPO) and Rules should be thoroughly reviewed prior to proceeding with the analysis.

Closed depressions generally facilitate infiltration of runoff. If a closed depression is classified as a wetland, then Minimum Requirement #8 for wetlands may apply. If there is an outflow from the wetland to a surface water (such as a creek), then the flow from the wetland must also meet Minimum Requirement #7 for flow control when the thresholds are met. WWHM must be used for closed depression analysis and design of mitigation facilities. If a closed depression is not classified as a wetland, model the ponding area at the bottom of the closed depression as an infiltration pond.

## 1.5 Bypass and Offsite Inflow - Considerations for Flow Control Facilities

### 1.5.1 Bypass

Bypass occurs when a portion of the development does not drain to a stormwater facility. Runoff may bypass the facility provided all the following conditions are met (unless using Equivalent Areas per Volume 1, Section 3.3.3):

1. Runoff from both the bypass area and the flow control facility converges within  $\frac{1}{4}$  mile downstream of the project site discharge point.
2. The flow control facility is designed to compensate for the uncontrolled bypass area such that the net effect at the point of convergence downstream is the same with or without bypass.
3. The 100-year return period flowrate from the bypass area will not exceed 0.4 cfs.
4. Runoff from the bypass area will not create a significant adverse impact to downstream drainage systems or properties.
5. Water quality requirements applicable to the bypass area are met.

### 1.5.2 Offsite Inflow

Offsite inflow occurs when an upslope area outside the project area drains to the stormwater facility in the development. If the existing 100-year peak return period flowrate from any upstream offsite area is greater than 50% of the 100-year developed return period flowrate (undetained) for the project site, then the runoff from the offsite area must not flow to the onsite flow control facility. The bypass of offsite runoff must be designed to achieve all of the following:

1. Any existing contributions or flows to an onsite wetland must be maintained.
2. Offsite flows that are naturally attenuated by the project site under predeveloped conditions must remain attenuated, either by natural means or by providing additional onsite detention so that return period flowrates do not increase. The system shall be modeled in WWHM.

## **1.6 Rounding**

Values shall typically be rounded to the nearest 100th for stormwater facility design or when determining which minimum requirements apply to a project. Environmental Services will make the final determination for appropriate rounding.

**Table 3 - 1: Runoff Curve Numbers for Selected Agricultural, Suburban and Urban Areas<sup>a</sup>**

Cover type and hydrologic condition	CNs for hydrologic soil group <sup>b</sup>			
	A	B	C	D
<b>Curve Numbers for Pre-Development Conditions</b>				
<b>Pasture, grassland, or range-continuous forage for grazing:</b>				
Fair condition (ground cover 50% to 75% and not heavily grazed)	49	69	79	84
Good condition (ground cover >75% and lightly or only occasionally grazed)	39	61	74	80
<b>Woods:</b>				
Fair condition (grazed but not burned, and some forest litter covers the soil)	36	60	73	79
Good condition (protected from grazing, and litter & brush adequately cover the soil)	30	55	70	77
<b>Curve Numbers for Post-Development Conditions</b>				
<b>Open space (lawns, parks, golf courses, cemeteries, landscaping, etc.):</b>				
Fair condition (grass cover on 50% to 75% of the area)	77	85	90	92
Good condition (grass cover on >75% of the area)	68	80	86	90
<b>Impervious areas:</b>				
Open water bodies (lakes, wetlands, ponds, etc.)	100	100	100	100
Paved parking lots, roofs, driveways, etc. (excluding right-of way)	98	98	98	98
Landscaped area	77	85	90	92
100% impervious area	98	98	98	98
<b>Pasture, grassland, or range-continuous forage for grazing:</b>				
Poor condition (ground cover <50% or heavily grazed with no mulch)	68	79	86	89
Fair condition (ground cover 50% to 75% and not heavily grazed)	49	69	79	84
Good condition (ground cover >75% and lightly or only occasionally grazed)	39	61	74	80
<b>Woods:</b>				
Poor condition (forest litter, small trees & brush are destroyed by heavy grazing or regular burning)	45	66	86	89
Fair condition (grazed but not burned, and some forest litter covers the soil)	36	60	73	79
Good condition (protected from grazing, and litter & brush adequately cover the soil)	30	55	70	77
<b>Percentage impervious for modeling fully-developed conditions</b>				
<b>Land use description<sup>c</sup></b>	<b>% impervious</b>			
Commercial	85			
Industrial	70			
Residential	60			

a. Source: Soil Conservation Services Technical Release No. 55 (210 - VI TR55, Second Edition, June 1986)

b. Sites in the City of Tacoma shall be considered Type C soils unless a site specific soils investigation is conducted.

c. For the land use descriptions, roads are included in the percentage impervious.



**This Page Intentionally Left Blank**

## Chapter 2 Roof Downspout Controls

### 2.1 Description

This section presents the criteria for design and implementation of roof downspout controls. *Roof downspout controls* are simple pre-engineered designs for infiltrating and/or dispersing runoff from roof areas for the purposes of increasing opportunities for groundwater recharge and reduction of runoff volumes from new development or redevelopment. This chapter may also be applicable for onsite management of other impervious surfaces, as allowed by Environmental Services.

This chapter provides guidance for roof downspout controls for meeting the intent of Minimum Requirement #5, Onsite Stormwater Management. It may be possible to use this guidance for meeting the intent of Minimum Requirement #7 as well.

Roof downspout controls are used in conjunction with, and in addition to, any additional flow control facilities that may be necessary to mitigate stormwater impacts from the overall development. Implementation of roof downspout controls may reduce the total effective impervious area and result in less runoff from these surfaces. Certain low impact development features can be modeled with WWHM which may reduce the flow control requirements. The modeling technique is described in each BMP as applicable.

### 2.2 Selection of Roof Downspout Controls

Per Minimum Requirement #5, Onsite Stormwater Management, all projects shall employ roof downspout controls to infiltrate, disperse and retain stormwater onsite to the maximum extent practicable.

See Volume 1, Section 3.4.5 to determine required order of preference for roof downspout controls. The type of roof downspout control required varies based upon the final receiving water.

### 2.3 Roof Downspout Infiltration

Roof downspout infiltration systems are systems designed for compliance with Minimum Requirement #5 and are intended for infiltrating stormwater runoff from roof downspouts.

BMP L601: Rain Gardens (Vol 6, Sec 2.2.2.1) and BMP L602: Roof Downspout Full Infiltration (Vol 3, Sec 2.3.3) can be used to meet the intent of Minimum Requirement #5.

#### 2.3.1 Downspout Infiltration Soils Report Requirements

See Volume 3, Appendix A to determine if a soils report is required for your project. Volume 3, Appendix A also provides the minimum required components of a soils report.

#### 2.3.2 BMP L601: Rain Gardens

See Volume 6, Section 2.2 for Rain Garden infeasibility criteria and design criteria.

### **2.3.3 BMP L602 Downspout Full Infiltration BMPs**

#### **2.3.3.1 Flow Credit for Roof Downspout Full Infiltration**

If roof runoff is infiltrated according to the requirements of this section, the area draining to the infiltration facility is not entered into WWHM. The area is still considered when determining project thresholds.

#### **2.3.3.2 Roof Downspout Infiltration Setbacks and Site Controls**

Setback requirements are generally required by Tacoma Municipal Code, Uniform Building Code, the Tacoma-Pierce County Health Department, or other state regulation. Where a conflict between setbacks occurs, the City shall require compliance with the most stringent of the setback requirements from the various codes/regulations. The following are the minimum setbacks required per this manual:

- At least 10 feet from any building structure and at least 5 feet from any other structure or property line unless approved in writing by Environmental Services.
- A minimum of 50 feet from the top of any steep (greater than 15%) slope. A geotechnical analysis must be prepared by a Washington State licensed Professional Engineer or Professional Geologist addressing impacts to facilities proposed within 50 feet of a steep (greater than 15%) slope. More stringent setbacks may be required based upon other portions of other Tacoma Municipal Code.
- At least 10 feet from septic tank and septic drainfields. Shall not be located upstream of septic systems unless topography or a hydrologic analysis clearly indicates that subsurface flows will not impact the drainfield.
- Environmental Services may require additional setbacks or analysis for infiltration facilities proposed to be sited within the influence of known contaminated sites or abandoned landfills.

Additional setbacks may be required by other local, state, or federal agencies. See the individual BMPs for BMP specific setback criteria.

#### **2.3.3.3 Infeasibility Criteria for Downspout Full Infiltration Systems**

A downspout full infiltration system is considered infeasible on a site if any of the following are true. See Volume 3, Appendix B to determine if a soils report is required.

- The setback criteria per Volume 3, Section 2.3.3.2 or the design standards per BMPL602a – Infiltration Trenches (Volume 3, Section 2.3.3.4) or BMP L602b - Drywells (Volume 3, Section 2.3.3.4) cannot be met.
- The particle size distribution of the soil is classified according to the USDA Textural Triangle (see Figure 3 - 1) as clay, sandy clay, silty clay, clay loam, silty clay loam, sandy clay loam, or silt based on ASTM Standard Test Method for Particle Size Analysis of Soils ASTM D422-63 (2002).
- The depth from proposed final grade to seasonal high groundwater table or other impermeable layer is less than 3 feet.
- The depth from the bottom of the infiltration trench to the seasonal high groundwater table or other impermeable layer is less than one foot.
- If any of the competing needs criteria are met (Vol 1, Sec 3.4.5.7).

## Soil Textural Triangle

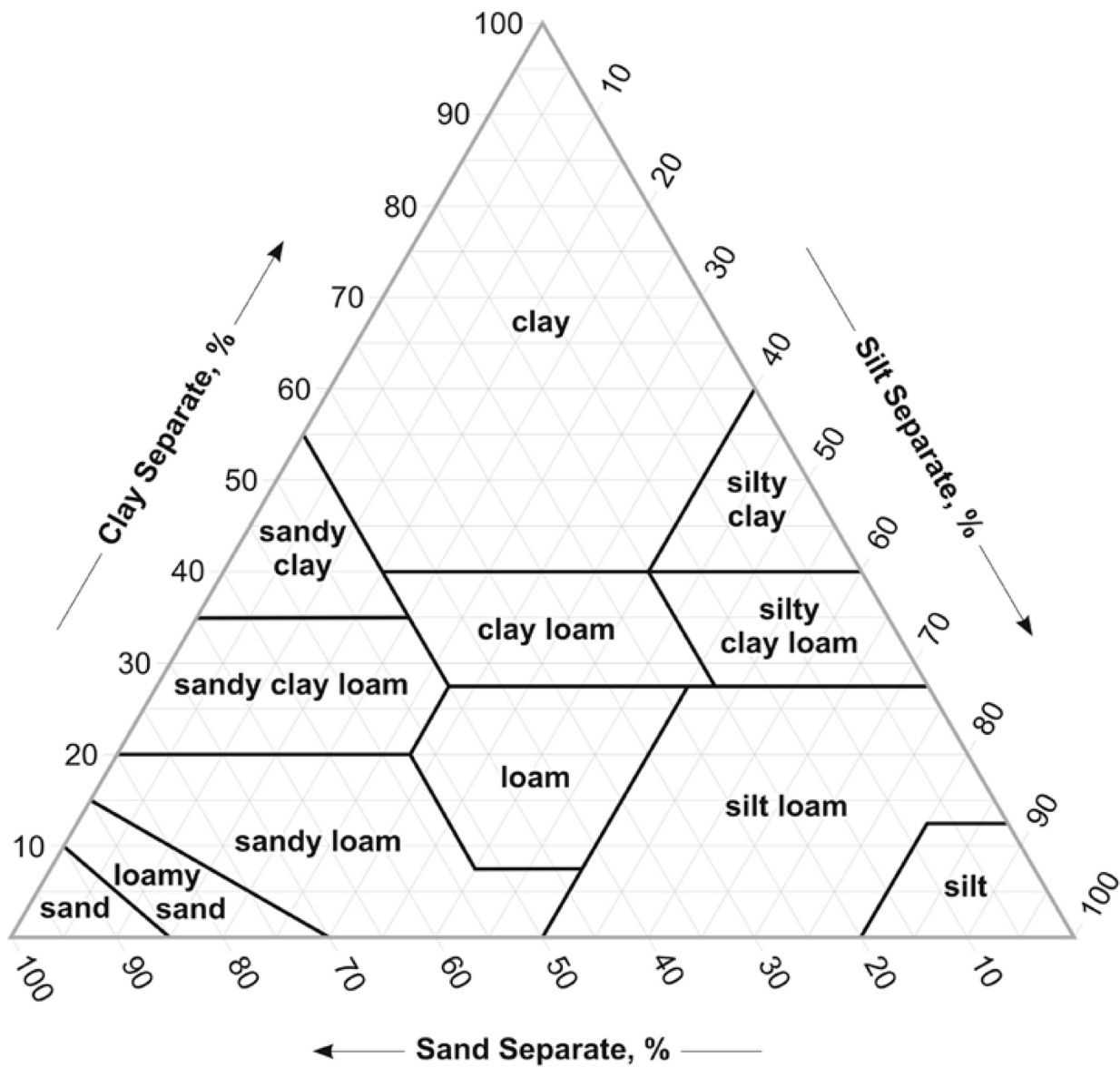


Figure 3 - 1. USDA Textural Triangle

### 2.3.3.4 BMP L602.a: Infiltration Trenches

#### Design Criteria for Downspout Infiltration Trenches

1. Use Figure 3 - 2 (also called Green Stormwater Infrastructure - Figure 001) which shows a typical downspout infiltration trench system, or Figure 3 - 3 which shows an alternative infiltration trench system for sites with coarse sand and cobble soils for design criteria. Applicants may use either of these designs in conjunction with the soils table and additional design criteria below or may model the site separately. Modeling must be conducted by a licensed engineer in the State of Washington.

2. The following minimum lengths (in linear feet [LF]) per 1,000 square feet of roof area based on soil type may be used for sizing downspout infiltration trenches. For soil types other than those presented in Table 3 - 2, additional geotechnical information and engineering analysis may be required by Environmental Services.

**Table 3 - 2: Downspout Infiltration Length for USDA Soil Type**

USDA Soil Type	Total Trench Length (linear feet)
“Coarse Sand” (more than 50% of sand fraction remains on a #4 sieve)	20
“Medium Sand” (more than 50% of the sand fraction remains on the #40 sieve)	30
Loamy Sand	75
Sandy Loam	125
Loam	190
Silt Loam	270
Fill (see note 8 below)	60

3. Maximum length of trench shall not exceed 100 feet from the inlet sump.
4. Minimum spacing between trenches shall be 6 feet measured from trench centerline.
5. Non-woven geotextile fabric shall be placed over the trench aggregate prior to backfilling. To help ensure no migration of native soil into the rock layer, a 6-inch minimum layer of sand may be used as a filter media at the bottom of the trench below the washed rock layer. Volume 5, Appendix B contains specifications for geotextile fabric. It is recommended to scarify the bottom of the facility 2", minimum to enhance infiltration capabilities.
6. Distribution pipe shall be minimum 4" PVC slotted or perforated pipe placed at 0% slope placed on a minimum 12" rock layer and covered with a minimum 2" of rock.
7. Rock layer shall be ¾" to 1½" washed rock or rock meeting WSDOT Specification 9-03.12(5). A minimum 12" layer of rock shall be placed under the perforated or slotted pipe.
8. Cleanouts are recommended at all bends in pipe and at the infiltration trench terminus for inspection and maintenance practices.
9. Catch basin or yard drain shall have a minimum 6" sump depth below tee.
10. A minimum of three feet of separation is required from the proposed final grade to the seasonal high groundwater table.
11. A minimum of 1 foot of separation is required from the bottom of the infiltration trench to the seasonal high groundwater table.
12. Infiltration trenches may be placed in fill material if the fill is placed and compacted under the direct supervision of a Washington State licensed geotechnical engineer or Washington State licensed professional civil engineer with geotechnical expertise, and if the measured infiltration rate is at least 8 inches per hour. Infiltration rates can be tested using the methods described in Section 6.4.3.
13. Trenches may be located under pavement if a small yard drain or catch basin with grate cover is placed at the end of the trench pipe such that overflow would occur out of the

catch basin at an elevation at least one foot below that of the pavement, and in a location which can accommodate the overflow without creating a significant adverse impact to downhill properties or drainage systems. This is intended to prevent saturation of the pavement in the event of system failure.

**2.3.3.5 BMP L602.b: Drywells**

**Design Criteria for Downspout Infiltration Drywells**

1. Figure 3 - 4 (also known as Green Stormwater Infrastructure Figure 002) shows a typical downspout infiltration drywell system. The applicant shall use this design in conjunction with the design criteria below.
2. A minimum of 1 foot of separation is required from the bottom of the drywell to the seasonal high groundwater table.
3. Drywells shall be 48 inches in diameter minimum and contain the washed rock volume specified below. The following minimum washed rock volumes per 1,000 square feet of roof areas based on soil type may be used for sizing the downspout dry well. For soil types other than those presented in Table 3 - 3, additional soils information and engineering analysis are required.

**Table 3 - 3: Downspout Infiltration Drywell Sizing Table**

USDA Soil Type	Volume of Washed Rock (cubic feet)	Dry Well Rock Layer Height
"Coarse Sand" - more than 50% of the sand fraction remains on #4 sieve	60	4'9"
"Medium Sand" - more than 50% of the sand fraction remains on the #40 sieve.	90	7'2"

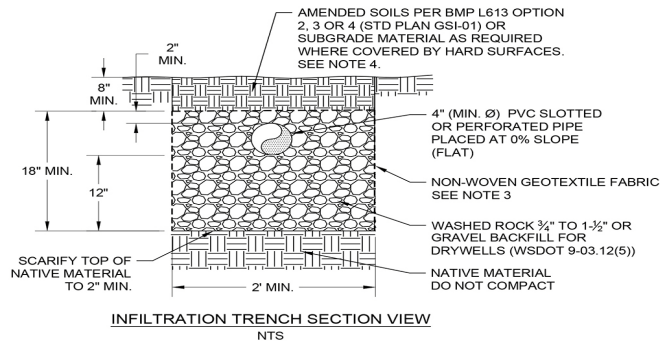
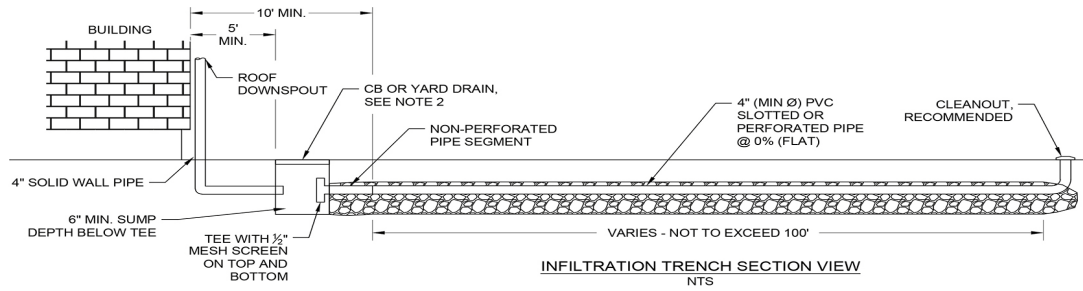
4. Washed rock shall be 1½ - 3" Washed Drain Rock with no fines.
5. Drywells shall have a minimum of 1' of amended soil placed above the rock layer.
6. Non-woven geotextile fabric shall be placed on the sides of the drywell and over the drain rock prior to backfilling.
7. Spacing between dry wells shall be a minimum of 10 feet, measured edge to edge.
8. Catch basin or yard drain shall have a minimum 6" sump depth below the tee.

**2.3.3.6 Maintenance Criteria**

Per Minimum Requirement #9, an operation and maintenance plan shall be prepared for all stormwater management facilities. See Volume 1, Appendix C, Maintenance Checklist #31 for specific maintenance requirements for downspout infiltration. Maintenance shall be a basic consideration in design and cost-determination of the stormwater management facility.

Any standing water removed during the maintenance operation must be disposed of in a City approved manner. See the dewatering requirements in Volume 4 of this manual. Pretreatment may be necessary. Solids must be disposed of in accordance with state and local waste regulations.

Facilities shall be designed and constructed to be safely and easily inspected by one person and safely and easily maintained. This may require the construction of additional inspection ports or access manholes.



**NOTES:**

1. Cleanouts recommended at pipe bends and end of trench.
2. Solid lid yard drain or catch basin shall be designed to be traffic bearing in areas subject to traffic.
3. Place non-woven geotextile fabric along walls and top of washed rock. Non-woven geotextile to conform to WSDOT Spec. 9-33.2(1), Tables 1 and 2.
4. All disturbed areas not covered with hard surfaces shall be stabilized by planting or mulching.



**CITY OF TACOMA  
GREEN STORMWATER INFRASTRUCTURE  
TYPICAL DETAILS**

**DOWNSPOUT INFILTRATION TRENCH**

**FIGURE NO.**

**001  
January 2016**

**Figure 3 - 2. Typical Downspout Infiltration Trench**

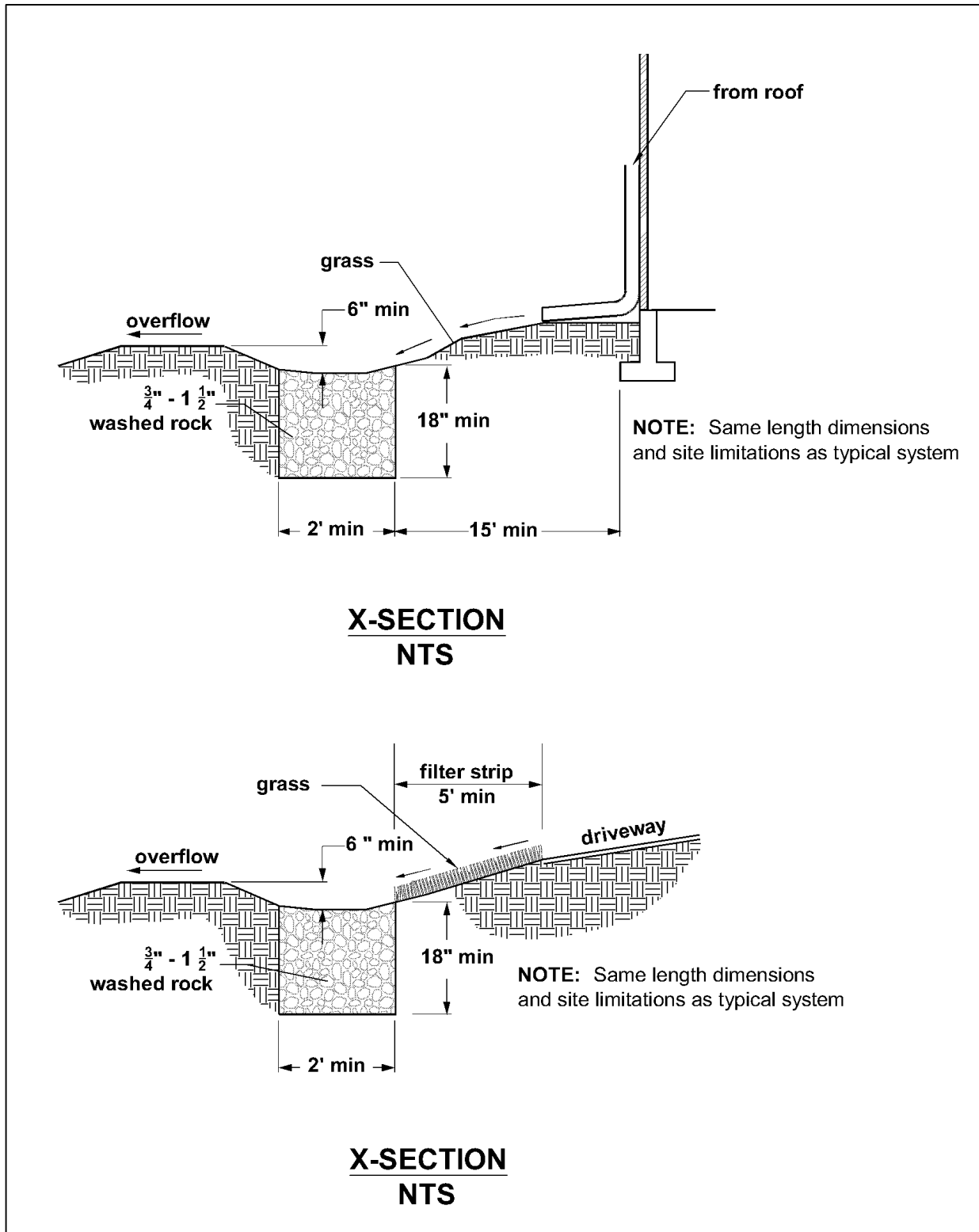
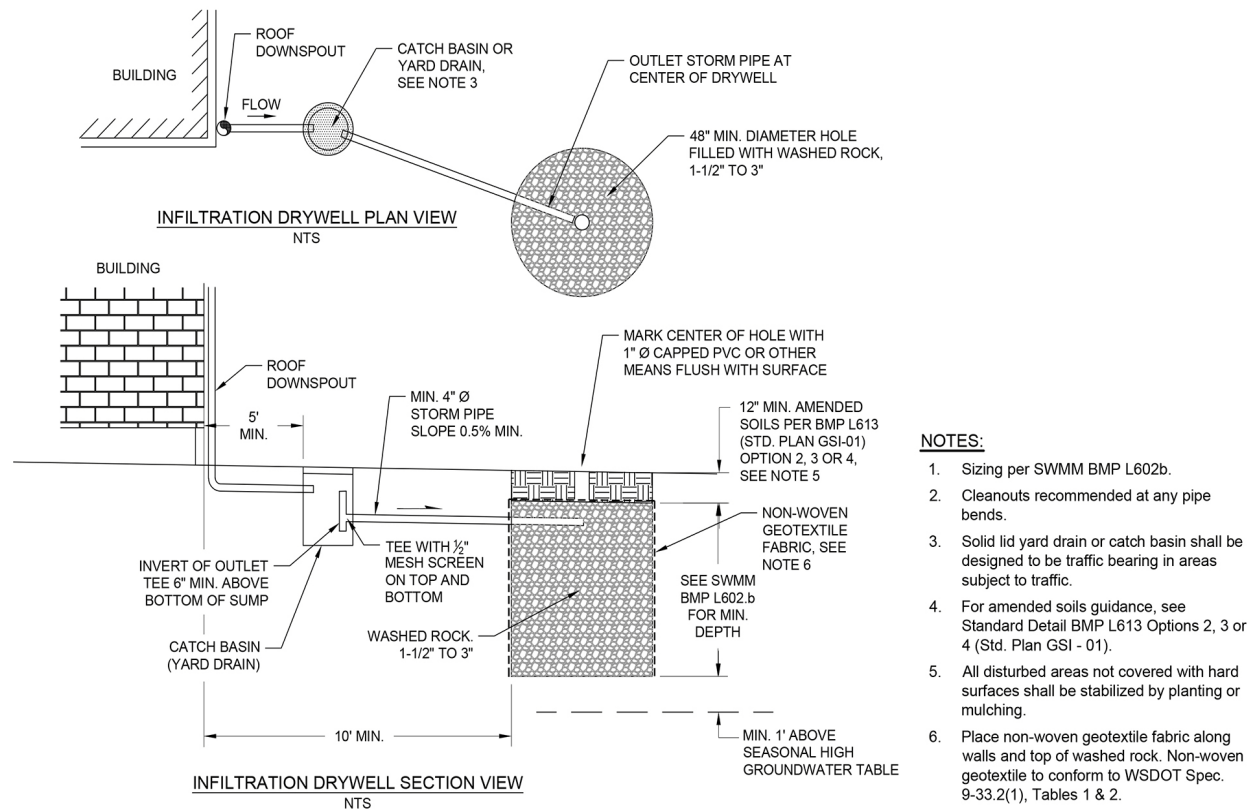


Figure 3 - 3. Alternative Infiltration Trench System for Coarse Sand and Gravel






 <p><b>CITY OF TACOMA</b> GREEN STORMWATER INFRASTRUCTURE TYPICAL DETAILS</p>	<b>DOWNSPOUT INFILTRATION DRYWELL</b>
	<p>FIGURE NO. <span style="float: right;">002</span></p> <p style="text-align: right;">January 2016</p>

Figure 3 - 4. Typical Downspout Infiltration Drywell

## 2.4 BMP L603 Downspout Dispersion Systems

*Downspout dispersion systems* are splash blocks or dispersion facilities that spread roof runoff over vegetated pervious areas. Dispersion attenuates peak flows by slowing entry of the runoff into the conveyance system, allowing for some infiltration, and providing some water quality benefits.

### 2.4.1 Application

See section 2.2 for selection of roof runoff controls.

### 2.4.2 Flow Credit for Roof Downspout Dispersion

If the roof runoff is dispersed according to the requirements of this section, model the connected roof area using the lateral flow element to send impervious area runoff onto the lawn/landscaped area that will be used for dispersion. To obtain flow credits, the vegetated flowpath shall be 50

feet or greater unless a dispersion trench per BMP L603.a is used, then the vegetated flowpath shall be 25 feet or greater. Model using WWHM.

*WWHM Modeling Guidance: Use the “Impervious Lateral Basin” element to represent the roof area(s). Use the “Pervious Lateral Flow Basin” element to represent the pervious area(s) into which the roof is being dispersed. Direct the “surface flow” from the “Impervious Lateral Flow Basin” element to the surface flow from the Pervious Lateral Basin element by connecting the elements. Then direct surface runoff and interflow from the Pervious Lateral Basin to the stormwater treatment or flow control facility or directly to the point of compliance as applicable.*

### **2.4.3 Roof Downspout Dispersion Setbacks and Site Controls**

Setback requirements are generally required by the Tacoma Municipal Code, Uniform Building Code requirements, the Tacoma-Pierce County Health Department, or other state regulation. Where a conflict between setbacks occurs, the City shall require compliance with the most stringent of the setback requirements from various codes/regulations. The following are the minimum setbacks required per this manual.

- At least 10 feet from any building and at least 5 feet from any property line or structure. If necessary, setbacks shall be increased from the minimum 5 feet in order to maintain a 1:1 side slope for future excavation and maintenance.
- A minimum of 50 feet from the top of any steep (greater than 15%) slope. A geotechnical analysis must be prepared by a Washington State licensed Professional Engineer or Professional Geologist addressing impacts to facilities proposed within 50 feet of a steep (greater than 15%) slope. More stringent setback requirements may be required based upon other portions of Tacoma Municipal Code.
- Figure 3 - 5 (also called Green Stormwater Infrastructure Figure 005) provides a plan set showing setback requirements for dispersion BMPs.

### **2.4.4 Infeasibility Criteria for Roof Downspout Dispersion**

A downspout dispersion system is considered infeasible on a site if any of the following are true.

- If any of the competing needs criteria are met (Vol 1, Sec 3.4.5.7).

#### ***Dispersion Trenches***

- The vegetated flowpath is less than 25 feet between the trench outlet and any property line, structure, stream, wetland, other infiltration or dispersion system, or impervious surface.
- The vegetated flowpath is less than 50 feet between the trench outlet and any slope 15% or greater.

Sensitive area buffers may count towards flowpath lengths if approved by the City of Tacoma.

#### ***Splashblocks***

- The vegetated flowpath is less than 50 feet between the discharge point and any property line, structure, slopes over 15%, stream, wetland, lake, other infiltration or dispersion system, or impervious surface.

Sensitive area buffers may count towards flowpath lengths if approved by the City of Tacoma.

**Both**

- The use of a splash block or dispersion trench would cause erosion or flooding problems onsite or on adjacent properties. Citation of this infeasibility criterion requires evaluation of site specific conditions and a stamped and signed memo or report from a Washington State licensed Professional Engineer.
- The setback criteria per Volume 3, Section 2.4.3 or the design standards per BMP L603a – Dispersion Trenches (Volume 3, Section 2.4.5) or BMP L603b - Splashblocks (Volume 3, Section 2.4.5) cannot be met.

**2.4.5 General Design Criteria for Roof Downspout Dispersion**

- Downspout dispersion trenches designed as shown in Figure or Figure 3 - 7 (also called Green Stormwater Infrastructure Figure 003 and Figure 004 available on govme.org under Standard Plans) should be used for all downspout dispersion applications except where splash blocks are allowed.
- For sites with septic systems, the discharge point must be downslope of the primary and reserve drainfield areas. This requirement may be waived if site topography clearly prohibits flows from intersecting the drainfield or where site conditions (soil permeability, distance between systems, etc) indicate that this is unnecessary.
- For sites with multiple dispersion systems, the outer edge of the vegetated flowpath segment for the dispersion trench must not overlap with other flowpath segments, except those associated with sheet flow from a native or non-native pervious surface.
- Runoff discharged towards landslide hazard areas must be evaluated by a geotechnical engineer or a licensed geologist, hydrogeologist, or engineering geologist. The discharge point shall not be placed on or above slopes greater than 15% or above erosion hazard areas without evaluation by a geotechnical engineer or qualified geologist and City approval.

***BMP L603.a: Design Criteria for Dispersion Trenches***

- Design dispersion trenches as shown in Figure 3 - 6 and Figure 3 - 7 (also called Green Stormwater Infrastructure Figure 003 and Figure 004).
- A vegetated flowpath of at least 25 feet in length must be maintained between the outlet of the trench and any property line, structure, stream, wetland, or impervious surface. A vegetated flowpath of at least 50 feet in length must be maintained between the outlet of the trench and any slope, 15% or greater. Sensitive area buffers may count towards flowpath lengths if approved by the City of Tacoma.
- Trenches serving up to 700 square feet of roof area may be simple 10-foot-long by 2-foot wide washed rock filled trenches as shown in Figure . For roof areas larger than 700 square feet, a dispersion trench with notched grade board may be used as approved by the City. The total length of this design must not exceed 50 feet and must provide at least 10 feet of trench per 700 square feet of roof area.
- Trenches shall not be placed closer than 10 feet from edge of trench to edge of trench or be placed closer than 100 feet along the flowpath.
- Distribution pipe shall be minimum 4" PVC slotted or perforated pipe placed at 0% slope.
- Rock layer shall be ¾" to 1½" washed rock or rock meeting WSDOT Specification 9-03.12(5). A minimum 12" layer of rock shall be placed under the perforated or slotted pipe.

- Cleanouts are recommended at all bends in pipe and at the trench terminus for inspection and maintenance practices.
- Catch basin or yard drain shall have a minimum 6" sump depth below tee.

### ***BMP L603.b: Design Criteria for Splashblocks***

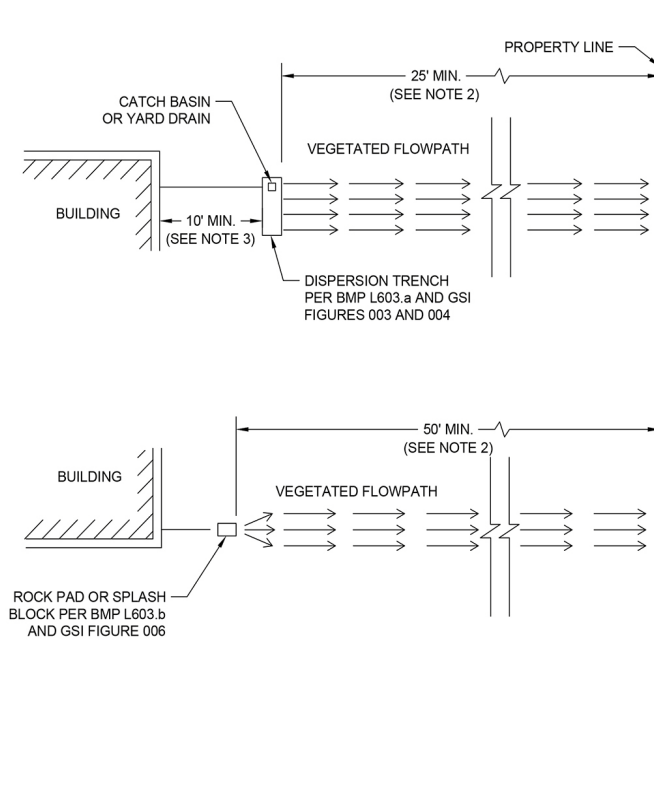
Design splashblocks as shown in Figure 3 - 8 (also known as Green Stormwater Infrastructure Figure 006). In general, if the ground is sloped away from the foundation and there is adequate vegetation and area for effective dispersion, splashblocks will adequately disperse storm runoff. If the ground is fairly level, if the structure includes a basement, or if foundation drains are proposed, splashblocks with downspout extensions may be a better choice because the discharge point is moved away from the foundation. Downspout extensions can include piping to a splashblock/discharge point a considerable distance from the downspout, as long as the runoff can travel through a well-vegetated area as described below.

- A vegetated flowpath of at least 50 feet shall be maintained between the discharge point and any property line, structure, slopes over 15%, stream, wetland, lake, or other impervious surface. Sensitive area buffers may count toward flowpath lengths.
- Flows shall not be directed onto sidewalks.
- A maximum of 700 square feet of roof area may drain to each splashblock.
- A splashblock or a pad of cobbles or ballast (2 feet wide by 3 feet long by 6 inches deep) shall be placed at each downspout discharge point.

### **2.4.6 Maintenance Criteria**

Per Minimum Requirement #9, an operation and maintenance plan shall be prepared for all stormwater management facilities. See Volume 1, Appendix C, Maintenance Checklist #32 for specific requirements for downspout dispersion. Maintenance shall be a basic consideration in design and cost-determination of the stormwater management facility.

Facilities shall be designed and constructed to be safely and easily inspected by one person and safely and easily maintained. This may require the construction of additional inspection ports or access manholes.



**NOTES:**

1. Per BMP L603.a, sensitive area buffers may count towards flowpath lengths if approved by the City of Tacoma.
2. Vegetative flowpath is measured from the downspout or dispersion system discharge point to the downstream property line, stream, wetland, or other hard surface. The vegetative flowpath shall be measured perpendicular to site contours. A vegetated flow path of at least 50 feet in length must be maintained between the outlet of the trench and any slope 15 % or greater.
3. The discharge point shall be at least 10 feet from any building structure and at least 5 feet from any other structure or property line unless approved by Environmental Services. If necessary, setbacks shall be increased from the minimum 10 feet in order to maintain a 1H:1V side slope for future excavation and maintenance.
4. Additional setbacks may be required by other local, state, or federal agencies. Where a conflict between setbacks occurs, the City shall require compliance with the most stringent of the setback requirements from various codes/regulations.



**CITY OF TACOMA  
GREEN STORMWATER INFRASTRUCTURE  
TYPICAL DETAILS**

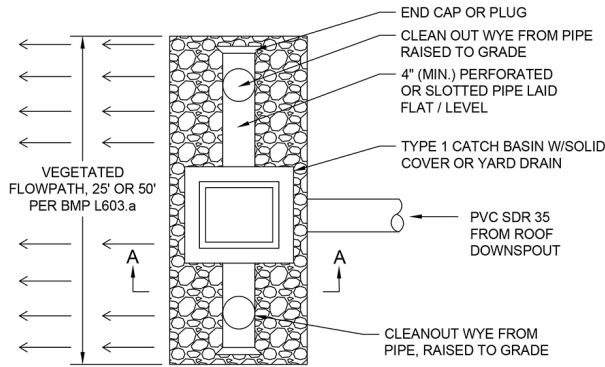
**SETBACKS FOR SPLASH BLOCKS AND  
TRENCH DISPERSION**

FIGURE NO.

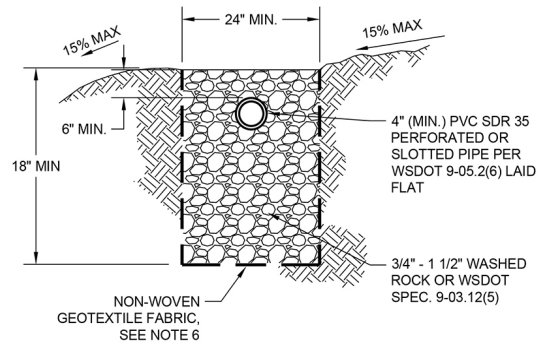
005

January 2016

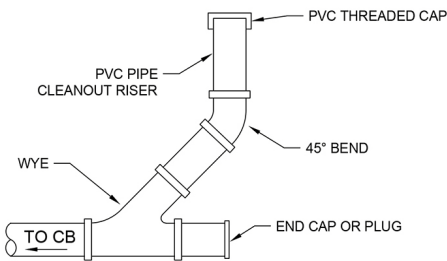
**Figure 3 - 5. Setbacks for Splashblocks and Trench Dispersion**



PLAN  
NTS



SECTION A-A  
NTS



CLEANOUT SECTION  
NTS

NOTES:

1. Trench may be placed no closer than 10 feet to another (100 feet along flowpath)
2. Trench must be level. Align to follow contours on site.
3. Trench may serve roof areas up to 700 square feet. For larger roof areas, refer to GSI Figure No. 004 - Dispersion Trench with Notched Grade Board.
4. Refer to SWMM BMP L603.a.
5. Trench length not to exceed 10 feet.
6. Place non-woven geotextile fabric along walls and bottom of washed rock. Non-woven geotextile to conform to WSDOT Spec. 9-33.2(1), Tables 1 and 2.



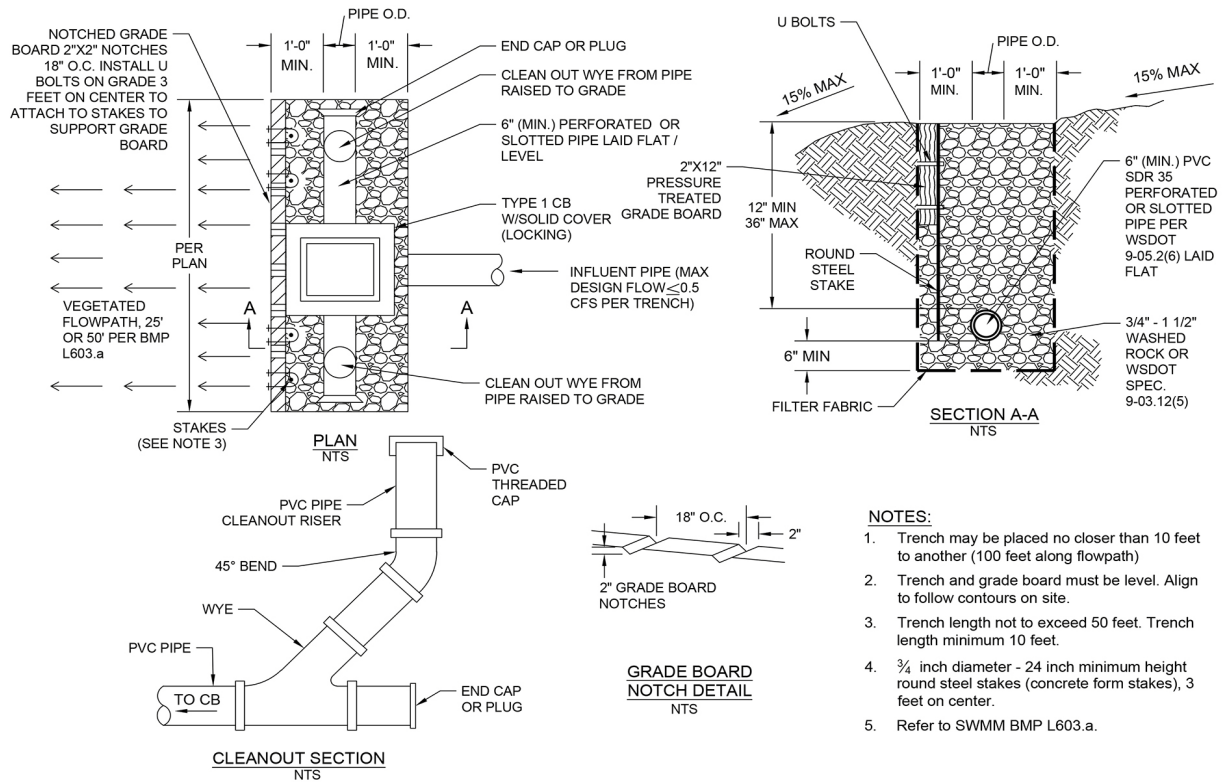
CITY OF TACOMA  
GREEN STORMWATER INFRASTRUCTURE  
TYPICAL DETAILS

DISPERSION TRENCH

FIGURE NO.

003  
January 2016

Figure 3 - 6. Downspout Dispersion Trench

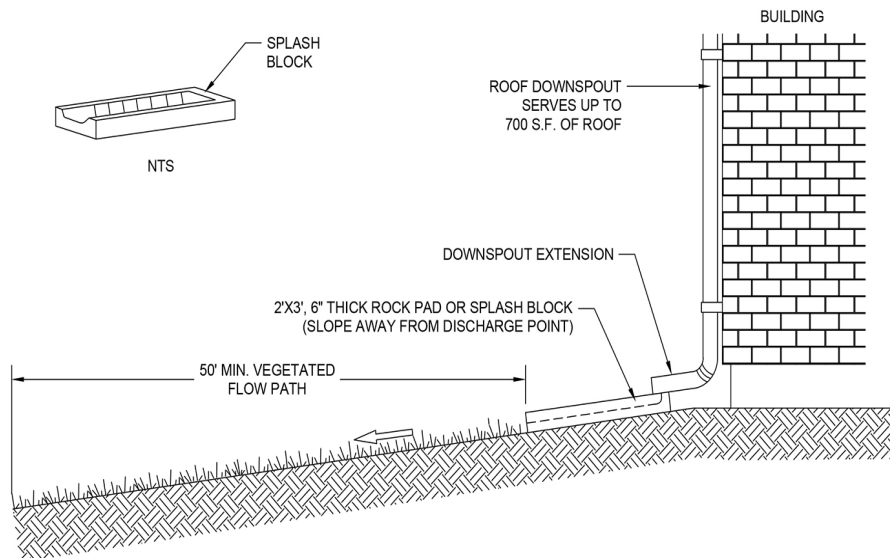


**CITY OF TACOMA  
GREEN STORMWATER INFRASTRUCTURE  
TYPICAL DETAILS**

**DISPERSION TRENCH WITH  
NOTCHED GRADE BOARD**  
FIGURE NO.

004  
January 2016

**Figure 3 - 7. Dispersion Trench with Notched Grade Board**



- NOTES:
1. Refer to Stormwater Management Manual BMP L603.b and GSI Figure 005 for setbacks.
  2. Splash block shall be concrete, plastic, or similar material. Commercially available splash blocks generally meet design criteria.
  3. Rock pad shall consist of 4" cobbles per WSDOT 9-03.11(2) or ballast meeting WSDOT 9-03.9(1).



CITY OF TACOMA  
GREEN STORMWATER INFRASTRUCTURE  
TYPICAL DETAILS

SPLASH BLOCK

FIGURE NO.

006

January 2016

Figure 3 - 8. Downspout Splashblock Dispersion

## 2.5 BMP L604: Perforated Stub-Out Connections

A perforated stub-out connection is a length of perforated pipe within a washed rock-filled trench that is placed between roof downspouts and a stub-out to the City stormwater system. See Volume 3, Section 2.6 and Volume 3, Section 10.5 for allowable connections to the City system. Figure 3 - 9 (also known as Green Stormwater Infrastructure Figure 007) provides design criteria for a perforated stub-out connection. These systems are intended to provide some infiltration during drier months. During the wet winter months, they may provide little or no flow control.

### 2.5.1 Application

- See Section 2.2 for Selection of Roof Runoff Controls.

### 2.5.2 Infeasibility Criteria for Perforated Stub-Out Connections

A perforated stub-out connection is considered infeasible if any of the following are true. See Volume 3, Appendix B to determine if a soils report is required.



- The setback criteria and design standards per BMP L604 (Volume 3, Section 2.5.3) cannot be met.
- The depth from the bottom of the trench to the seasonal high groundwater table or other impermeable layer is less than one foot. Citation of this infeasibility criterion requires evaluation of site specific conditions and a soils report (see Volume 3, Appendix B).
- If any of the competing needs criteria are met (Vol 1, Sec 3.4.5.7).

### 2.5.3 Design Criteria

- A minimum of one foot of separation is required from the bottom of the trench section to the seasonal high groundwater table.
- Perforated stub-out connections consist of at least 10 feet of perforated pipe per 5,000 square feet of roof area laid in a level, 2-foot wide trench backfilled with washed drain rock. Extend the drain rock to a depth of at least 8 inches below the bottom of the pipe and cover the pipe. Lay the pipe level and cover the rock trench with filter fabric and 6 inches of amended soil. (see Figure 3 - 9).
- Select the location of the connection to allow a maximum amount of runoff to infiltrate into the ground (ideally a dry, relatively well drained, location).
- To facilitate maintenance, do not locate the perforated pipe portion of the system under impervious or heavily compacted (e.g., driveways and parking areas) surfaces.
- Perforated stub-outs may be placed in fill material if the fill is placed and compacted under the direct supervision of a geotechnical engineer or professional civil engineer with geotechnical expertise, and if the measured infiltration rate is at least 8 inches per hour.
- Non-woven geotextile fabric shall be placed over the trench aggregate prior to backfilling. To help ensure no mitigation of native soil into the rock layer, a 6-inch minimum layer of sand may be used as a filter media at the bottom of the trench below the washed rock layer. Volume 5, Appendix B contains specifications for geotextile fabric.
- Distribution pipe shall be minimum 4" PVC slotted or perforated pipe placed at 0% slope.
- Rock layer shall be ¾" to 1½" washed rock or rock meeting WSDOT Specification 9-03.12(5). A minimum 12" layer of rock shall be placed under the perforated or slotted pipe.

The following are minimum setbacks:

- At least 10 feet from any building structure and at least 5 feet from any other structure or property line unless approved in writing by Environmental Services.
- Perforated pipe systems shall not be built on slopes steeper than 20%. A geotechnical analysis and report shall be required on slopes over 15% or if located within 50 feet of the top of steep slopes (40% or greater) or a landslide hazard area. More stringent setbacks may be required based upon other portions Tacoma Municipal Code.
- At least 10 feet from septic tank and septic drainfields. The perforated pipe shall not be located upstream of septic systems unless topography or a hydrologic analysis clearly indicates that subsurface flows will not impact the drainfield.
- Additional setbacks may be required by other local, state, or federal agencies.

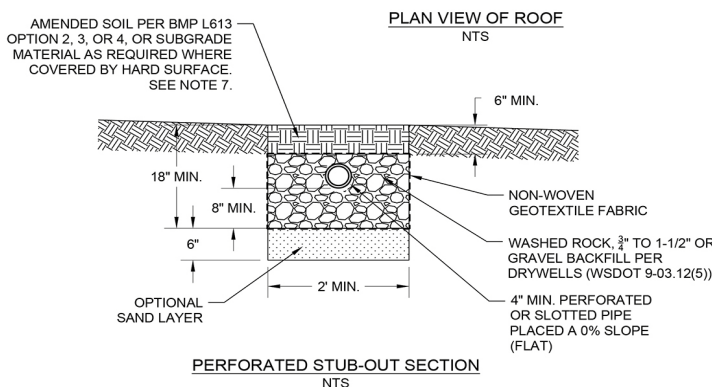
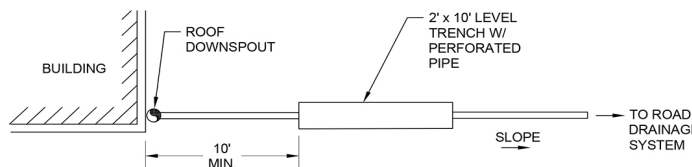
### 2.5.4 Flow Credit for Perforated Stubouts

Flow credits are not applicable to perforated stub-out connections. Any flow reduction is variable and unpredictable. No computer modeling techniques are allowed that would predict any reduction in flow rates and volumes from the connected area.

### 2.5.5 Maintenance Criteria

Per Minimum Requirement #9, an operation and maintenance plan shall be prepared for all stormwater management facilities. Maintenance shall be a basic consideration in design and cost-determination of the stormwater management facility.

Facilities shall be designed and constructed to be safely and easily inspected by one person and safely and easily maintained. This may require the construction of additional inspection ports or access manholes



**NOTES:**

1. Provide 10 feet of perforated pipe per 5,000 square feet of roof area laid in a level, 2-foot wide trench.
2. 3/4" - 1 1/2" washed rock or WSDOT Specification 9-03.12(5).
3. Place non-woven geotextile fabric along walls, bottom, and top of washed rock. Non-woven geotextile to conform to WSDOT Spec. 9-33.2(1), Tables 1 and 2.
4. A minimum one foot of separation is required from the trench bottom to the seasonal high ground water.
5. Perforated stub-out to be sized and located per SWMM BMP L604.
6. Do not build on slopes steeper than 20%.
7. All disturbed areas not covered with hard surfaces shall be stabilized by planting and mulching.
8. Cleanouts recommended at pipe bends and one end of the perforated section.



**CITY OF TACOMA  
GREEN STORMWATER INFRASTRUCTURE  
TYPICAL DETAILS**

**PERFORATED STUB-OUT CONNECTION**

FIGURE NO.

**007  
January 2016**

*Figure 3 - 9. Perforated Stub-Out Connections*

## 2.6 BMP L605 Collect and Convey

Where it can be demonstrated that infiltration and dispersion are not feasible for roof downspout controls, it may be allowable to collect and convey to the City stormwater system. This may be either the curb and gutter, if present, or the actual pipe and structure conveyance system. Connections to the curb and gutter or asphalt wedge curb shall comply with City of Tacoma Standard Plans SU-29 and SU-29a available at govme.org under Standard Plans.

Conveyance to the curb will only be allowed if a catch basin is located within 350 feet downstream of the discharge point. If a catch basin is not located within 350 feet of the discharge location, a storm main extension shall be required.

Minimum pipe size for conveyance to the curb shall be 3 inches in diameter. Where capacity greater than a 3 inch diameter pipe is required, Environmental Services shall review the proposal and may require a storm main extension.

**NOTE:** Environmental Services will only approve on a case-by-case basis those facilities that would require more than one through-curb discharge point.

For total roof areas 2,000 to 5,000 sf, roof runoff may be allowed to be collected and conveyed to either the curb or directly connected to a structure. The runoff shall not be conveyed over driveways, sidewalks or other areas reserved for pedestrian traffic. A detail for the discharge shall be submitted to Environmental Services for review and approval.

An analysis of the downstream system may be required before the applicant can discharge stormwater to the City system. See Minimum Requirement #10 (Vol. 1, Sec. 3.4.10) to determine if an analysis of the downstream system will be required.

No flow credits will be allowed for the collect and convey option.

## Chapter 3 Dispersion BMPs

### 3.1 BMP L611 Concentrated Flow Dispersion

#### 3.1.1 Purpose and Definition

Dispersion of concentrated flows from driveways or other pavement through a vegetated pervious area attenuates peak flows by slowing entry of the runoff into the conveyance system, allows for some infiltration, and provides some water quality benefits.

#### 3.1.2 Applications and Limitations

- Any situation where concentrated flow can be dispersed through vegetation.

#### 3.1.3 Infeasibility Criteria for Concentrated Flow Dispersion

- Concentrated flow dispersion is considered infeasible if the setback criteria and design standards in Volume 3, Section 3.1.4 and 3.1.5 cannot be met.
- If any of the competing needs criteria are met (Vol 1, Sec 3.4.5.7).

#### 3.1.4 Design Criteria

- Figure 3 - 10 (also called Green Stormwater Infrastructure - Figure 009) shows design criteria for concentrated flow dispersion from driveways.
- A maximum of 700 square feet of impervious area may drain to each concentrated flow dispersion BMP.
- Maintain a minimum vegetated flowpath of 25 feet between the discharge point and any property line, structure, steep slope, stream, lake, wetland, lake, or other hard surface for concentrating flows into a dispersion trench.
- Maintain a minimum vegetated flowpath of 50 feet between the discharge point and any property line, structure, steep slope, stream, lake, wetland, lake, or other hard surface for concentrating flows onto a rock pad.
- Asphalt or concrete berms used to concentrate flow shall be 2-4" in height and 6" in width.
- Trench drains shall be modular slotted drain units with a minimum width of 4 inches.
- Place a dispersion trench per BMP L603.a or a pad of clean crushed rock or 4" cobbles per WSDOT 9-03.11(2) that is 2 feet wide by 3 feet long by 6 inches deep at each discharge point.
- No erosion or flooding of downstream properties shall result.

#### 3.1.5 Setback Criteria

Setback requirements are generally required by Tacoma Municipal Code, Uniform Building Code, the Tacoma Pierce County Health Department, or other state regulations. Where a conflict between setbacks occurs, the City shall require compliance with the most stringent of the setback requirements from the various codes/regulations. The following are the minimum setbacks required per this manual. Additional setbacks may be required by other local, state or federal agencies.

- All facilities shall be a minimum of 50 feet from the top of any steep (greater than 15%) slope. A geotechnical analysis must be prepared addressing impacts to facilities

proposed within 50 feet of a steep (greater than 15%) slope. More stringent setbacks may be required based upon other portions of Tacoma Municipal Code.

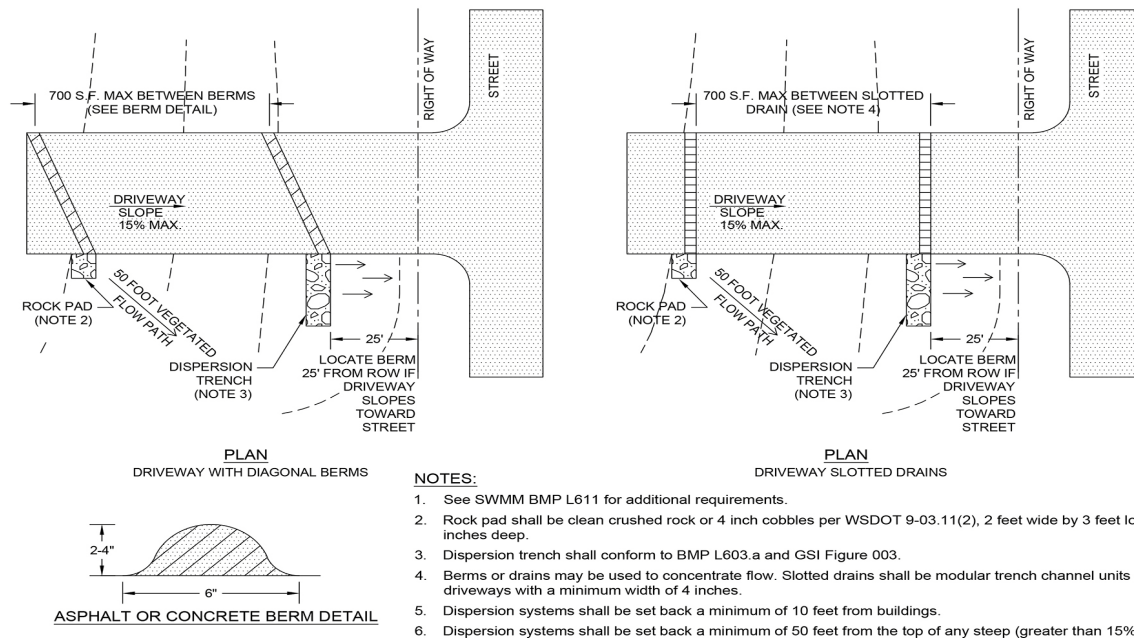
- The discharge point shall be at least 10 feet from any building structure and at least 5 feet from any other structure or property line unless approved in writing by Environmental Services. If necessary, setbacks shall be increased from the minimum 10 feet in order to maintain a 1H:1V side slope for future excavation and maintenance.
- At least 10 feet from septic tanks and septic drainfields. Shall not be located upstream of septic systems unless topography or a hydrologic analysis clearly indicates that subsurface flows will not impact the drainfield.
- Environmental Services may require additional setbacks or analysis for dispersion facilities proposed to be sited within the influence of known contaminated sites or abandoned landfills.

### **3.1.6 Flow Credits for Concentrated Flow Dispersion**

If the runoff is dispersed according to the requirements of this section into an undisturbed native landscape area or an area amended to meet BMP L613 and the vegetated flowpath is 50 feet in length, model the connected area using the lateral flow element to send the impervious area onto the lawn/landscaped area that will be used for dispersion. The deduction cannot be applied to pollutant-generating surfaces. If the thresholds for water quality treatment are met, water quality treatment is required.

### **3.1.7 Maintenance:**

Per Minimum Requirement #9, an operation and maintenance manual shall be prepared for all stormwater management facilities. Maintenance shall be a basic consideration in design and cost-determination of the stormwater management facility.



	<p><b>CITY OF TACOMA GREEN STORMWATER INFRASTRUCTURE TYPICAL DETAILS</b></p>	<p align="center"><b>CONCENTRATED FLOW DRIVEWAY DISPERSION</b></p> <p>FIGURE NO. <span style="float: right;">009</span></p> <p align="right">January 2016</p>
--	--	---

*Figure 3 - 10. Typical Concentrated Flow Dispersion for Steep Driveways*

## 3.2 BMP L612 Sheet Flow Dispersion

### 3.2.1 Purpose and Definition

Sheet flow dispersion is the simplest method of runoff control. This BMP can be used for any impervious or pervious surface that is graded so as to avoid concentrating flows. Because flows are already dispersed as they leave the surface, they need only traverse a narrow band of adjacent vegetation for effective attenuation and some treatment.

### 3.2.2 Applications and Limitations

Flat or moderately sloping (<15% slope) surfaces such as driveways, sport courts, patios, and roofs without gutters; non-native landscaping, lawn, and/or pasture; or any situation where concentration of flows can be avoided.

### 3.2.3 Infeasibility Criteria for Sheet Flow Dispersion

- Concentrated flow dispersion is considered infeasible if the setback criteria and design standards in Volume 3, Section 3.2.4 and 3.2.5 cannot be met.
- If any of the competing needs criteria are met (Vol 1, Sec 3.4.5.7).

### 3.2.4 Design Criteria

- See Figure 3 - 11 (also called Green Stormwater Infrastructure - Figure 008) for details for driveways.

- Provide a 2-foot-wide transition zone to discourage channeling between the edge of the impervious surface and the downslope vegetation, or under building eaves. This may be an extension of subgrade material (crushed rock), modular pavement, drain rock, or other material acceptable to the City.
- Provide a vegetated flowpath width of 10 feet for up to 20 feet of width of paved or impervious surface. Add an additional 10 feet of width for each additional 20 feet of impervious surface width or fraction thereof.
- Provide a vegetated flowpath width of 25 feet for up to 150 feet of contributing cleared area (i.e., non-native landscaping, lawn, and/or pasture). Slopes within the 25-foot minimum vegetated flowpath should be no steeper than 8 percent. If this criterion cannot be met due to site constraints, the 25-foot vegetated flowpath length must be increased 1.5 feet for each percent increase in slope above 8%.
- No erosion or flooding of downstream properties may result.

### **3.2.5 Setback Criteria**

Setback requirements are generally required by City of Tacoma Municipal Code, Uniform Building Code, the Tacoma Pierce County Health Department, or other state regulations. Where a conflict between setbacks occurs, the City shall require compliance with the most stringent of the setback requirements from the various codes/regulations. The following are the minimum setbacks required per this manual. Additional setbacks may be required by other local, state, or federal agencies.

- All systems shall be at least 10 feet from any building structure and at least 5 feet from any other structure or property line unless approved in writing by Environmental Services. If necessary, setbacks shall be increased from the minimum 10 feet in order to maintain a 1H:1V side slope for future excavation and maintenance.
- All facilities shall be a minimum of 50 feet from the top of any steep (greater than 15%) slope. A geotechnical analysis must be prepared addressing impacts to facilities proposed within 50 feet of a steep (greater than 15%) slope. More stringent setbacks may be required based upon other portions of Tacoma Municipal Code.
- All systems shall be located at least 10 feet from septic tanks and septic drainfields. Shall not be located upstream of septic systems unless topography or a hydrologic analysis clearly indicates that subsurface flows will not impact the drainfield.
- Environmental Services may require additional setbacks or analysis for dispersion facilities proposed to be sited within the influence of known contaminated sites or abandoned landfills.

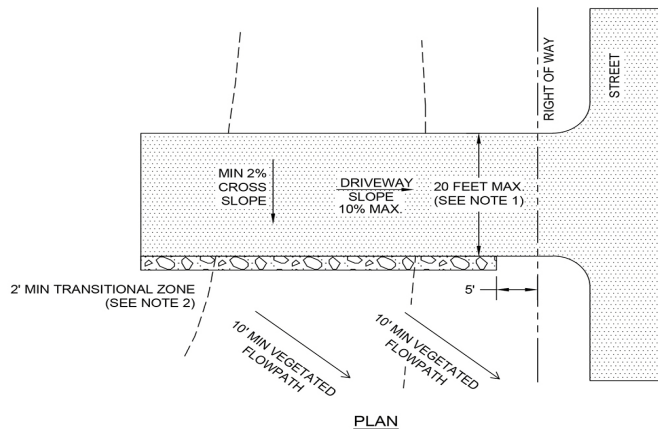
### **3.2.6 Flow Credits for Sheet Flow Dispersion**

If the runoff is dispersed according to the requirements of this section into an undisturbed native landscape area or an area amended to meet BMP L613, model the connected area using the lateral flow element to send the impervious area onto the lawn/landscaped area that will be used for dispersion. The deduction cannot be applied to pollutant-generating surfaces. If the thresholds for water quality treatment are met, water quality treatment is required.

### **3.2.7 Maintenance Criteria**

Per Minimum Requirement #9, an operation and maintenance plan shall be prepared for all stormwater management facilities. Maintenance shall be a basic consideration in design and cost-determination of the stormwater management facility.

Facilities shall be designed and constructed to be safely and easily inspected by one person and safely and easily maintained.



**NOTES:**

1. For driveways greater than 20 feet in width, additional flow path is required. See SWMM BMP L612.
2. Transition zone material may be crushed rock, modular pavement, drain rock or other material approved by the City.
3. Dispersion systems shall set back a minimum 10 feet from buildings and a minimum of 5 feet from property line unless approved in writing by the City.
4. Dispersion systems shall be set back a minimum of 50 feet from the top of any steep (greater than 15%) slope.



**CITY OF TACOMA  
GREEN STORMWATER INFRASTRUCTURE  
TYPICAL DETAILS**

**SHEET FLOW DISPERSION  
FOR DRIVEWAYS**  
FIGURE NO.

**008**  
January 2016

*Figure 3 - 11. Sheet Flow Dispersion for Driveways*

### 3.3 BMP L614 Full Dispersion

#### 3.3.1 Purpose and Definition

This BMP allows for "fully dispersing" runoff from impervious surfaces and cleared areas of development sites that preserve at least 65% of the site (or a threshold discharge area on the site) in a forest or native condition. Native conditions are comprised of native vegetation.

#### 3.3.2 Applications and Limitations

- For residential development projects, full dispersion can be used as long as the developed areas draining to the native vegetation do not have impervious surfaces that exceed 10% of the entire site.
- Other types of development that retain 65% of the site (or a threshold discharge area on the site) in a forested or native condition may also use these BMPs to avoid triggering the flow control facility requirement.
- The preserved area may be a previously cleared area that has been replanted in accordance with native vegetation landscape specifications described within this BMP.
- Situate the preserved area to minimize the clearing of existing forest cover, to maximize the preservation of wetlands, and to buffer stream corridors.



- Wetlands, streams, and lakes do not count toward the 65% forest or native condition area.
- A covenant and easement agreement or separate recorded tract of land will be required to protect the preserved area.
- Show the preserved area on all maps and plans and clearly mark the area during clearing and construction.
- Retain all trees within the preserved area (except as allowed in the bullet below for passive recreation), aside from approved timber harvest activities regulated under WAC Title 222, except for Class IV General Forest Practices that are conversions from timberland to other uses, and the removal of dangerous or diseased trees.
- The preserved area may be used for passive recreation with related recreational facilities, including pedestrian and bicycle trails, nature viewing area, fishing and camping areas, and other similar activities that do not require permanent structures, provided that cleared areas and areas of compacted soil associated with these areas and facilities do not exceed eight percent of the preserved area.
- The preserved area may contain utilities and utility easements, but not septic systems.

### 3.3.3 Design Guidelines for Residential Projects

- Where a development has less than 65% of a site available to maintain or create into a forested or native condition, that area may still be used for full dispersion of a portion of the developed area. The ratio of the native vegetation area to the impervious area, which is dispersed into the native vegetation, must not be less than 65 to 10. The lawn and landscaping area must comply with BMP L613.
- The portion of the developed area which is not managed through full dispersion can be considered a separate project site and be separately evaluated to determine project thresholds.
- Runoff must be dispersed into the native area in accordance with the design criteria specified for the dispersion type. A native vegetated flowpath of at least 100 feet in length (25 feet for sheet flow from a non-native pervious surface) is required from the discharge point to any downstream drainage feature such as a pipe, ditch, stream, river, pond, lake, or wetland or downstream property line. The native vegetated flowpath shall meet all the following criteria:
  - The flowpath shall be over a native vegetated surface.
  - The flowpath shall be onsite or in an offsite tract or easement area reserved for dispersion.
  - The slope of the flowpath shall not exceed 15% for any 20-foot reach of the flowpath. Slopes up to 33% are allowed where level spreaders are located upstream of the dispersion area and at sites where vegetation can be established.
  - The flowpaths for adjacent dispersion devices must be sufficiently spaced to prevent overlap of flows in the flowpath areas.
- The dispersion of runoff shall not create flooding or erosion impacts.
- **Roof Downspouts** - Roof surfaces are considered to be "fully dispersed" (i.e., at or approaching zero percent effective imperviousness) only if they are within a threshold discharge area that is or will be more than 65% forested (or native vegetative cover) and less than 10% impervious (total), AND if they either: 1) comply with BMP L603: Downspout Dispersion Systems, but with vegetated flowpaths of 100 feet or more

through a native vegetation area; or 2) disperse the roof runoff along with the road runoff in accordance with the roadway dispersion BMP section below.

- **Driveway Dispersion** - Driveway surfaces are considered to be "fully dispersed" if they are within a threshold discharge area that is or will be more than 65% forested (or native vegetative cover) and less than 10% impervious (total), AND if they either: 1) comply with BMP L603: Downspout Dispersion Systems, but with vegetated flowpaths of 100 feet or more through a native vegetation area; or 2) disperse the roof runoff along with the road runoff in accordance with the roadway dispersion BMP section below.
- **Roadway Dispersion BMPs** - Roadway surfaces are considered to be "fully dispersed" if they are within a threshold discharge area that is or will be more than 65% forested (or native vegetative cover) and less than 10% impervious (total), and if they comply with the following dispersion requirements:
  - Design the road section to minimize collection and concentration of roadway runoff. Use sheet flow over roadway fill slopes (i.e., where roadway subgrade is above adjacent right-of-way) wherever possible to avoid concentration.
  - When it is necessary to collect and concentrate runoff from the roadway and adjacent upstream areas (e.g., in a ditch on a cut slope), concentrated flows shall be incrementally discharged from the ditch via cross culverts or at the ends of cut sections. These incremental discharges of newly concentrated flows shall not exceed 0.5 cfs at any one discharge point from a ditch for the 100-year return period flowrate. Where flows at a particular ditch discharge point were already concentrated under existing site conditions (e.g., in a natural channel that crosses the roadway alignment), the 0.5 cfs limit would be in addition to the existing concentrated peak flows.
  - Ditch discharge points with up to 0.2 cfs discharge for the 100-year return period flowrate shall use rock pads or dispersion trenches to disperse flows. Ditch discharge points with between 0.2 and 0.5 cfs discharge for the 100-year return period flowrate shall use only dispersion trenches to disperse flows.
  - Ditch discharge points shall be located a minimum of 100 feet upgradient of slopes steeper than 40%, wetlands, and streams.
  - Dispersion trenches shall be designed to accept storm flows (free discharge) from a pipe, culvert, or ditch end, shall be aligned perpendicular to the flowpath, and shall be minimum 2 feet by 2 feet in section, 50 feet in length, filled with ¾-inch to 1½-inch washed rock, and provided with a level notched grade board (see Figure 3 - 7). Manifolds may be used to split flows up to 2 cfs discharge for the 100-year return period flowrate between up to 4 trenches. Dispersion trenches shall have a minimum spacing of 50 feet between center lines.
  - After being dispersed with rock pads or trenches, flows from ditch discharge points must traverse a minimum of 100 feet of undisturbed native vegetation before leaving the project site, or entering an existing onsite channel carrying existing concentrated flows across the road alignment.
  - Flowpaths from adjacent discharge points must not intersect within the 100-foot flowpath lengths, and dispersed flow from a discharge point must not be intercepted by another discharge point. To enhance the flow control and water quality effects of dispersion, the flowpath shall not exceed 15% slope, and shall be located within designated open space.

- Where the City determines there is a potential for significant adverse impacts downstream (e.g., erosive steep slopes or existing downstream drainage problems), dispersion of roadway runoff may not be allowed, or other measures may be required.

### **3.3.4 Setback Criteria**

Setback requirements are generally required by Tacoma Municipal Code, Uniform Building Code, the Tacoma Pierce County Health Department, or other state regulations. Where a conflict between setbacks occurs, the City shall require compliance with the most stringent of the setback requirements from the various codes/regulations. The following are the minimum setbacks required per this manual. Additional setbacks may be required by other local, state, or federal agencies.

- All systems shall be at least 10 feet from any building structure and at least 5 feet from any other structure or property line unless approved in writing by Environmental Services. If necessary, setbacks shall be increased from the minimum 10 feet in order to maintain a 1H:1V side slope for future excavation and maintenance.
- All facilities shall be a minimum of 50 feet from the top of any steep (greater than 15%) slope. A geotechnical analysis must be prepared addressing impacts to facilities proposed within 50 feet of a steep (greater than 15%) slope. More stringent setbacks may be required based upon other portions of Tacoma Municipal Code.
- Discharge points shall not be placed on slopes steeper than 20 percent. A geotechnical analysis and report shall be required on slopes over 15% or if located within 200 feet of the top of steep slopes (40% or greater) or a landslide hazard area. More stringent setbacks may be required based upon other portions of the Tacoma Municipal Code.
- Discharge points shall be at least 10 feet from septic tanks and septic drainfields. Shall not be located upstream of septic systems unless topography or a hydrologic analysis clearly indicates that subsurface flows will not impact the drainfield.
- Environmental Services may require additional setbacks or analysis for dispersion facilities proposed to be sited within the influence of known contaminated sites or abandoned landfills

### **3.3.5 Cleared Area Dispersion BMPs**

The runoff from cleared areas (non-native landscaping, lawn, and/or pasture) can be considered fully dispersed if the following criteria is met:

- Provide a 25-foot-wide vegetated flowpath for up to 25 foot-width of cleared area. Provide an additional 1 foot of vegetated flowpath for every additional 3 feet of width beyond 25 feet up to a maximum cleared area width of 250 feet.
- Slopes within the dispersal area shall not exceed 15%.

### **3.3.6 Design Guidelines for Road-Related Projects**

#### **3.3.6.1 Uncollected or Natural Dispersion into Adjacent Vegetated Areas**

The runoff will be considered fully dispersed for sites that meet the following criteria based on soil type:

- Outwash Soils (Type A- Sand and Sandy Gravels and Some Type B – Loamy Sands)

- Must have an initial saturated hydraulic conductivity rate of 4 inches per hour or greater. The saturated hydraulic conductivity must be based on an in-situ infiltration method as identified in Volume 3, Section 6.5.
- Provide a 10-foot-wide vegetated flowpath for up to 20 feet of impervious surface flowpath. Provide an additional 0.25 foot of vegetated flowpath for every additional 1 foot of impervious flowpath.
- Other Soils (Type C and D and Type B not meeting the criteria above)
  - Provide a 6.5-foot-wide vegetated flowpath for every 1 foot width of impervious surface draining to it. The minimum distance shall be 100 feet.

The following criteria must be met for the runoff to be considered fully dispersed for all soil types:

- The minimum depth to the average annual maximum groundwater depth shall be 3 feet.
- Impervious surface flowpaths shall be less than 75 feet.
- Pervious surface flowpaths shall be less than 150 feet. Pervious surface flowpaths are considered those upgradient road side slopes that run onto the road and down gradient road side slopes that precede the dispersion area.
- Lateral slope of impervious drainage area shall be less than 8%.
- Road side slopes shall be less than 25%. Road side slopes do not count as part of the dispersion area unless native vegetation is reestablished and slopes are less than 15%.
- Road shoulders that are paved or graveled to withstand occasional vehicle loading are considered impervious surfaces.
- Longitudinal slope of road shall be less than 5%.
- Length of dispersion area shall be equivalent to length of the road.
- Average longitudinal (parallel to road) slope of dispersion area shall be less than 15%.
- Average lateral slope of dispersion area shall be less than 15%.

### **3.3.6.2 Channelized Dispersion**

This section describes the criteria for channelized (collected and redispersed) stormwater runoff into areas with native vegetation.

The runoff will be considered fully dispersed for sites that meet the following criteria based on soil type:

- Outwash Soils (Type A- Sand and Sandy Gravels and Some Type B – Loamy Sands)
  - Must have an initial saturated hydraulic conductivity rate of 4 inches per hour or greater. The saturated hydraulic conductivity must be based on an in-situ infiltration method as identified in Volume 3, Section 6.5.
  - Provide a vegetated flowpath of at least ½ of the impervious drainage area.
- Other Soils (Type C and D and Type B not meeting the criteria above)
  - Provide a 6.5-foot-wide vegetated flowpath for every 1 foot width of impervious surface draining to it. The minimum distance shall be 100 feet.

The following criteria must be met to be considered fully dispersed for all soil types:

- The minimum depth to the average annual maximum groundwater depth shall be 3 feet.

- Channelized flow shall be redispersed to produce the longest possible flowpath.
- Flows shall be evenly dispersed across the vegetated flowpath.
- Flows shall be dispersed using rock pads and dispersion techniques as specified under Roadway Dispersion BMPs. Other energy dissipation techniques may be used as approved by Environmental Services.
- The impervious surface area is limited to onsite (associated with roads only) flows.
- Length of dispersion area shall be equivalent to length of the road.
- Average longitudinal and lateral slopes of the dispersion areas shall be less than or equal to 8%.
- The slopes of any flowpath segment shall be less than 15% for any 20-foot reach of the flowpath segment.

### **3.3.6.3 Engineered Dispersion**

This section describes the criteria for engineered dispersion of stormwater runoff into an area with engineered soils. Stormwater can be dispersed via sheet flow or via collection and redispersion in accordance with the techniques specified under Roadway Dispersion BMPs.

The runoff will be considered fully dispersed for sites that meet the following criteria based on soil type:

- Outwash Soils (Type A- Sand and Sandy Gravels and Some Type B – Loamy Sands)
  - Must have an initial saturated hydraulic conductivity rate of 4 inches per hour or greater. The saturated hydraulic conductivity must be based on an in-situ infiltration method as identified in Volume 3, Section 6.5.
  - Soils must be compost amended in accordance with BMP L613: Post-Soil Quality and Depth.
  - Provide a 10-foot-wide vegetated flowpath for up to 20 feet of impervious surface flowpath. Provide an additional 0.25 foot of vegetated flowpath for every additional 1 foot of impervious flowpath.
- Other Soils (Type C and D and Type B not meeting the criteria above)
  - Soils must be compost amended in accordance with BMP L613: Post-Soil Quality and Depth.
  - Provide a dispersion area meeting the 65:10 ratio.

The following criteria must be met to be considered fully dispersed for all soil types:

- The minimum depth to the average annual maximum groundwater depth shall be 3 feet.
- Flows shall be evenly dispersed across the vegetated flowpath.
- Average longitudinal and lateral slopes of the dispersion areas shall be less than or equal to 15%.
- The dispersion area shall be planted with native trees and shrubs where possible.
- A covenant and easement agreement or separate recorded tract of land will be required to protect the preserved area.

### 3.3.7 Native Vegetation Landscape Specifications

The following design criteria may be used in areas where previously developed surfaces are being converted to a native vegetation area for purposes of meeting full dispersion requirements.

Conversion of a developed surface to native vegetation landscape requires the removal of impervious surface, decompaction of soils, and the planting of native trees, shrubs, and groundcover in compost-amended soil. The following criteria must be met:

- Existing impervious surface and any underlying base course shall be completely removed from the conversion area(s).
- Underlying soil shall be scarified to a depth of 18 inches.
- A minimum of 4 inches of well-decomposed compost shall be tilled into the scarified soils. The finished surface should be gently undulating and lightly compacted.
- Plant the area of native vegetation with native species trees, shrubs, and groundcover. Select species appropriate for the site's shade and moisture conditions and in accordance with the following requirements:
  - Trees: Plant a minimum of two tree species, one species shall be an evergreen. Space trees at the recommendation of a professional landscaper or according to other City of Tacoma landscape codes as applicable. Where frequent watering is not practical, bare-root stock may be substituted at variable spacing from 10 to 12 feet on center. Bare root stock types shall be 1-1, 2-1, P-1 and P-2. Live stakes at 4 feet on center may be substituted for willow and red-osier dogwood in wet areas.
  - Shrubs: Plant a minimum of two species of shrubs. Space plants to cover landscaped area, except where trees are present. Where frequent watering is not practical, bare-root stock may be substituted at variable spacing from 4 to 6 feet on center. Bare root stock types shall be 1-1, 2-1, P-1 and P-2.
  - Groundcover: Plant a minimum of two species of ground cover. Space plants to cover all remaining bare soils.
  - Increase the number of native species if possible based upon native vegetation area size.
- Place at least 4 inches of mulch between plants for weed control.
- Water plantings as necessary to ensure proper plant growth.
- A minimum of 90% plant survival is required after 3 years.

Conversion of an area under cultivation to native vegetation requires elimination of non-native cultivated plants, grasses, and weeds before planting and continuously during native vegetation establishment. The following criteria must be met:

- Till the soil to a minimum depth of 18 inches.
- The soil shall:
  - Be a minimum of 8 inches having an organic content of 6-12%, OR
  - Place a 4 inch layer of compost on the surface before planting, OR
  - Till 4 inches of clean wood chips into the soil (only upon recommendation of a landscape architect or forester)

- Plant the area of native vegetation with native species trees, shrubs, and ground cover. Select species appropriate for the site's shade and moisture conditions and in accordance with the following requirements:
  - Trees: Plant a minimum of two tree species, one species shall be an evergreen. Space trees at the recommendation of a landscape professional or according to other City of Tacoma landscape codes as applicable. Where frequent watering is not practical, bare-root stock may be substituted at variable spacing from 10 to 12 feet on center. Bare root stock types shall be 1-1, 2-1, P-1 and P-2. Live stakes at 4 feet on center may be substituted for willow and red-osier dogwood in wet areas.
  - Shrubs: Plant a minimum of two species of shrubs. Space plants to cover landscaped area, except where trees are present. Where frequent watering is not practical, bare-root stock may be substituted at variable spacing from 4 to 6 feet on center. Bare root stock types shall be 1-1, 2-1, P-1 and P-2.
  - Groundcover: Plant a minimum of two species of ground cover. Space plants to cover all remaining bare soils.
  - Increase the number of native species if possible based upon native vegetation area size.
- Place at least 4 inches of mulch or compost between plants for weed control.
- Water plantings as necessary to ensure proper plant growth.
- A minimum of 90% plant survival is required after 3 years.

### **3.3.8 Flow Credits for Full Dispersion**

Sites that can fully disperse are not required to provide water quality treatment or flow control facilities.

## Chapter 4 Soil Quality BMPs

### 4.1 BMP L613 Post-Construction Soil Quality and Depth

#### 4.1.1 Purpose and Definition

Naturally occurring (undisturbed) soil and vegetation provide important stormwater functions including: water infiltration; nutrient, sediment, and pollutant adsorption; sediment and pollutant biofiltration; water interflow storage and transmission; and pollutant decomposition. These functions are largely lost when development strips away native soil and vegetation and replaces it with minimal topsoil and sod. Not only are these important stormwater functions lost, but such landscapes themselves become pollution generating pervious surfaces due to increased use of pesticides, fertilizers and other landscaping and household/industrial chemicals, the concentration of pet wastes, and pollutants that accompany roadside litter.

#### 4.1.2 Applications and Limitations

- Soil amendments are required for the disturbed areas of sites subject to Minimum Requirement #5.
- Where Minimum Requirement #5 does not apply, and the site is proposing a traditional lawn installation, compost-amended lawn soil is strongly encouraged.
- Use soil amendments in areas that will be incorporated into the stormwater drainage system such as vegetated channels, rain gardens, bioretention areas, and lawn and landscaped areas.
- Soil organic matter can be attained using various materials such as compost, composted woody material, biosolids, and first product residuals. The material used to meet the soil quality and depth BMP shall be appropriate and beneficial to plant establishment.
- Imported topsoils shall not have an excessive percent of fines.

#### 4.1.3 Infeasibility Criteria for Soil Quality BMPs

- Post-Construction soil quality and depth is considered infeasible on slopes greater than 33%. Citation of this infeasibility criterion requires evaluation of site specific conditions.
- If any of the competing needs criteria are met (Vol 1, Sec 3.4.5.7).

#### 4.1.4 Design Criteria

##### Soil Retention

- Retain the duff layer and native topsoil in an undisturbed state to the maximum extent practicable. In any areas requiring grading, remove and stockpile the duff layer and topsoil onsite in a designated, controlled area, not adjacent to public resources and critical areas, to be reapplied to other portions of the site where feasible. Use appropriate BMPs to ensure retained soil does not enter the stormwater system.

##### Soil Quality

- All areas subject to clearing and grading that will not be covered by impervious surface, incorporated into a drainage facility or engineered as structural fill or slope shall, at project completion, demonstrate the following:



- A topsoil layer with a minimum organic matter content of ten percent dry weight in planting beds, and minimum 5% organic matter content in turf areas, and a pH from 6.0 to 8.0 or matching the pH of the original undisturbed soil.
- The topsoil layer shall have a minimum depth of eight inches except where tree roots limit the depth of incorporation of amendments needed to meet the criteria. Subsoils below the topsoil layer should be scarified at least 4 inches with some incorporation of the upper material to avoid stratified layers, where feasible.
- Planting beds have been mulched with 2 inches of organic material
- To meet the organic content requirements above use either:
  - A compost meeting the definition for “composted material” per WAC 173-350-100 and complying with standards in WAC 173-350-220, except the feedstock may contain biosolids or manure feedstocks.
  - Compost applied at the Preapproved Rate (see Table 3 - 4) meeting the following specifications:
    - Meet the definition for “composted material” per WAC 173-350-100 and comply with standards in WAC 173-350-220, except the feedstock may contain biosolids or manure feedstocks.
    - Have no visible water or dust during handling.
    - Have soil organic matter content of 40% to 65%.
    - Have a carbon to nitrogen ratio below 25:1. Carbon to nitrogen ratio may be as high as 35:1 for plantings composed entirely of plants native to the Puget Sound Lowlands region.

City of Tacoma TAGRO mix can be used as an alternative to the compost component.

Compost specifications can also be found in Volume 5, Appendix E.

OR
  - Compost applied at a Calculated Rate (see Table 3 - 5) meeting the following specifications:
    - Meet the definition for “composted material” per WAC 173-350-100 and comply with standards in WAC 173-350-220, except the feedstock may contain biosolids or manure feedstocks.
    - Have no visible water or dust during handling.
    - Have soil organic matter content of 40% to 65%.
    - Have a carbon to nitrogen ratio below 25:1. Carbon to nitrogen ratio may be as high as 35:1 for plantings composed entirely of plants native to the Puget Sound Lowlands region.

City of Tacoma TAGRO mix can be used as an alternative to the compost component.

Compost specifications can also be found in Volume 5, Appendix E.

OR

- Other organic material applied at a Calculated Rate (see Table 3 - 5) meeting the following specifications:
  - Have a carbon to nitrogen ratio below 25:1. Carbon to nitrogen ratio may be as high as 35:1 for plantings composed entirely of plants native to the Puget Sound Lowlands region.
- Not exceeding contaminant limits identified in Table 220-B, Testing Parameters, in WAC 173-350-220.
- The resulting soil shall be conducive to the type of vegetation to be established.

City of Tacoma Standard Plan GSI-01 provides a graphical representation of BMP L613. The Standard Plan is available in Volume 6, Appendix B.

#### **4.1.5 Implementation Options:**

Use one of the following options to meet the post construction soil quality and depth requirements. Use the information in this BMP and the most recent version of “Guidelines for Resources for Implementing Soil Quality and Depth BMP T5.13” to meet the requirements of this BMP. This guidance can be found online at: [www.buildingsoil.org](http://www.buildingsoil.org).

- Option 1.** Leave native vegetation and soil undisturbed, and protect from compaction during construction.
- Option 2.** Amend existing site topsoil or subsoil either at default Preapproved Rates (see Table 3 - 4), or at Calculated Rate (see Table 3 - 5) based on tests of the soil and amendment.
- Option 3.** Stockpile existing topsoil during grading, and replace it prior to planting. Stockpiled topsoil must also be amended if needed to meet the organic matter or depth requirements, either at a default Preapproved Rates (see Table 3 - 4) or at a Calculated Rate (see Table 3 - 5).
- Option 4.** Import topsoil mix of sufficient organic content and depth to meet the requirements.

More than one method may be used on different portions of the same site. Soil that already meets the depth and organic matter quality standards, and is not compacted, does not need to be amended.

**Table 3 - 4: Amendment Options**

<p><b>OPTION 1: Leave native vegetation and soil undisturbed, and protect from compaction during construction</b></p> <p>Identify areas of the site that will not be stripped, logged, graded or driven on, and fence off those areas to prevent impacts during construction. If neither soils nor vegetation are disturbed these areas do not require amendments.</p>	
<p><b>OPTION 2: Amend existing site topsoil or subsoil either at Preapproved Rate or at Calculated Rate based on the tests of the soil and amendments</b></p>	
<p><b>Scarification</b></p> <ul style="list-style-type: none"> <li>• Scarify or till subgrade to 8 inches depth (or to depth needed to achieve a total depth of 12 inches of uncompacted soil after calculated amount of amendment is added).</li> <li>• Entire surface should be disturbed by scarification.</li> <li>• Do not scarify within drip line of existing trees to be retained.</li> <li>• Amend soil to meet required organic content.</li> </ul>	
<p><b>A. Planting Beds</b></p> <ol style="list-style-type: none"> <li>1. <b>PREAPPROVED RATE:</b> Place 3 inches of composted material and rototill into 5 inches of existing site soil (a total amended depth of about 9.5 inches, for a settled depth of 8 inches).</li> <li>2. <b>CALCULATED RATE:</b> Place calculated amount of composted material or approved organic material and rototill into depth of soil needed to achieve 8 inches of settled soil at 10% organic content.</li> </ol> <ul style="list-style-type: none"> <li>• Rake beds to smooth and remove surface rocks larger than 2 inches diameter.</li> <li>• Mulch planting beds with 2 inches of organic mulch or stockpiled duff.</li> </ul>	<p><b>B. Turf Areas</b></p> <ol style="list-style-type: none"> <li>1. <b>PREAPPROVED RATE:</b> Place 1.75 inches of composted material and rototill into 6.25 inches of existing site soil (a total amended depth of about 9.5 inches, for a settled depth of 8 inches).</li> <li>2. <b>CALCULATED RATE:</b> Place calculated amount of composted material or approved organic material and rototill into depth of soil needed to achieve 8 inches of settled soil at 5% organic content.</li> </ol> <ul style="list-style-type: none"> <li>• Water or roll to compact soil to 85% of maximum dry density.</li> <li>• Rake to level, and remove surface rocks larger than 1 inch diameter.</li> </ul>
<p><b>OPTION 3: Stockpile existing topsoil during grading, and replace it prior to planting. Stockpiled topsoil must also be amended if needed to meet the organic matter or depth requirements, either at a default Preapproved Rate or at a Calculated Rate.</b></p>	

**Table 3 - 4: Amendment Options**

<p><b>Scarification.</b></p> <ul style="list-style-type: none"> <li>• If placed topsoil plus compost or other organic material will amount to less than 12 inches: Scarify or till subgrade to depth needed to achieve 12 inches of loosened soil after topsoil and amendment are placed.</li> <li>• Entire surface should be disturbed by scarification.</li> <li>• Do not scarify within drip line of existing trees to be retained.</li> <li>• Stockpile and cover soil with weed barrier material that sheds moisture yet allows air transmission, in approved location, prior to grading.</li> <li>• Replace stockpiled topsoil prior to planting. Amend if needed to meet required organic content.</li> </ul>	
<p><b>A. Planting Beds</b></p> <ol style="list-style-type: none"> <li>1. PREAPPROVED RATE: Place 3 inches of composted material and rototill into 5 inches of replaced soil (a total amended depth of about 9.5 inches, for a settled depth of 8 inches).</li> <li>2. CALCULATED RATE: Place calculated amount of composted material or approved organic material and rototill into depth of replaced soil needed to achieve 8 inches of settled soil at 10% organic content.</li> </ol> <ul style="list-style-type: none"> <li>• Rake beds to smooth and remove surface rocks larger than 2 inches diameter.</li> <li>• Mulch planting beds with 2 inches of organic mulch or stockpiled duff.</li> </ul>	<p><b>B. Turf Areas</b></p> <ol style="list-style-type: none"> <li>1. PREAPPROVED RATE: Place 1.75 inches of composted material and rototill into 6.25 inches of replaced soil (a total amended depth of about 9.5 inches, for a settled depth of 8 inches).</li> <li>2. CALCULATED RATE: Place calculated amount of composted material or approved organic material and rototill into depth of replaced soil needed to achieve 8 inches of settled soil at 5% organic content.</li> </ol> <ul style="list-style-type: none"> <li>• Water or roll to compact soil to 85% of maximum dry density.</li> <li>• Rake to level, and remove surface rocks larger than 1 inch diameter.</li> </ul>
<p><b>OPTION 4: Import topsoil mix of sufficient organic content and depth to meet the requirements.</b></p>	
<p><b>Scarification.</b></p> <ul style="list-style-type: none"> <li>• Scarify or till subgrade in two directions to 6 inches depth.</li> <li>• Entire surface should be disturbed by scarification.</li> <li>• Do not scarify within drip line of existing trees to be retained</li> </ul>	

**Table 3 - 4: Amendment Options**

<b>A. Planting Beds</b>	<b>B. Turf Areas</b>
<ul style="list-style-type: none"> <li>• Use imported topsoil mix containing 10% organic matter (typically around 40% compost). Soil portion must be sand or sandy loam as defined by the USDA.</li> <li>• Place 3 inches of imported topsoil mix on surface and till into 2 inches of soil.</li> <li>• Place second lift of 3 inches topsoil mix on surface.</li> <li>• Rake beds to smooth, and remove surface rocks over 2 inches diameter.</li> <li>• Mulch planting beds with 2 inches of organic mulch.</li> </ul>	<ul style="list-style-type: none"> <li>• Use imported topsoil mix containing 5% organic matter (typically around 25% compost). Soil portion must be sand or sandy loam as defined by the USDA.</li> <li>• Place 3 inches of imported topsoil mix on surface and till into 2 inches of soil.</li> <li>• Place second lift of 3 inches topsoil mix on surface.</li> <li>• Water or roll to compact soil to 85% of maximum.</li> <li>• Rake to level, and remove surface rocks larger than 1 inch diameter</li> </ul>

**Table 3 - 5: Calculated Amendment Rate****CALCULATING CUSTOM AMENDMENT RATES TO ACHIEVE A TARGET SOIL ORGANIC MATTER CONTENT**

Where soils already have some organic content, it is often cost-effective to calculate the amount of compost amendment needed to achieve the target 10% soil organic matter for landscape beds or 5% for turf areas, rather than using the preapproved rates.

Custom amendment rates can be calculated using either the equation below, or the Compost Amendment Rate Calculator available as an Excel spreadsheet online at [www.SoilsforSalmon.org](http://www.SoilsforSalmon.org).

**EQUATION FOR CALCULATING COMPOST APPLICATION RATES:**

Use this equation to calculate compost application rates to achieve the target final soil organic matter content (10% for landscape beds or 5% for turf areas) for a soil with a given bulk density and initial soil organic matter.

$$CR = D * \frac{SBD * (SOM\% - FOM\%)}{SBD * (SOM\% - FOM\%) - CBD * (COM\% - FOM\%)}$$

Where:

CR = Compost application rate (inches) calculated needed to achieve the target final organic matter (FOM)

D = Depth of finished incorporation (inches)

SBD = Soil bulk density (lb/cubic yard dry weight)\*

SOM % = Initial soil organic matter (%)\*\*\*

FOM% = Final target soil organic matter (%)\*\*\*

CBD = Compost bulk density (lb/cubic yard dry weight)\*\*

COM% = Compost organic matter (%)\*\*\*

Assumption: This equation calculates compost rate using an additive approach. For example, a 3-inch compost rate incorporated to an 8-inch depth will be a final mix containing 3/8 compost and 5/8 soil by volume.

\* To convert Soil Bulk Density in g/cm<sup>3</sup> units to lb/cubic yard, multiply by 1697.

\*\*To convert Compost Bulk Density from lb/cubic yard “as is” to lb/cubic yard dry weight, multiply by solids content.

\*\*\*All Organic Matter measurements are based on the commonly used “loss-on-combustion” method.

#### **4.1.6 Maintenance**

- Establish soil quality and depth toward the end of construction and once established, protect from compaction, such as from large machinery use, and from erosion.
- Plant vegetation and mulch the amended soil area after installation.
- Leave plant debris or its equivalent on the soil surface to replenish organic matter.
- Reduce and adjust, where possible, the use of irrigation, fertilizers, herbicides and pesticides, rather than continuing to implement formerly established practices. Follow Integrated Pest Management (IPM) techniques.

#### **4.1.7 Flow Reduction Credits for BMP L613**

In WWHM 2012, for sizing flow control devices, areas meeting the design guidelines may be modeled as pasture rather than lawn. The deduction cannot be applied to pollutant-generating surfaces. If the thresholds for water quality treatment are met, water quality treatment is required.

Flow reduction credits can be taken in runoff modeling when Post-Construction Soil Quality and Depth is used as part of a dispersion design under the conditions described in:

- BMP L603 Downspout Dispersion Systems
- BMP L611 Concentrated Flow Dispersion
- BMP L612 Sheet Flow Dispersion

## Chapter 5 BMP L615 Tree Retention & Transplanting

Trees provide flow control via interception, transpiration, and increased infiltration. Additional environmental benefits include improved air quality, carbon sequestration, reduced heat island effect, pollutant removal, and habitat preservation or formation.

When implemented in accordance with the criteria outlined below, retained and newly planted trees receive credits toward meeting flow control requirements. The degree of flow control provided by a tree depends on the tree type (i.e., evergreen or deciduous), crown area, and whether or not the tree crown overhangs impervious surfaces.

### 5.1 Applications and Limitations

Trees are a landscape amenity with flow control benefits that can be applied in most settings. Flow control credit is given for retaining or transplanting trees.

### 5.2 Retained Trees

#### 5.2.1 Site Considerations

Setbacks of proposed infrastructure from existing trees are a critical consideration. Tree protection requirements limit grading and other disturbances in proximity to the tree.

#### 5.2.2 Design Criteria

The following provides requirements and recommendations associated with tree retention for flow control credit. Review submittal shall include the existing tree species, trunk diameter, crown area (and dripline delineation), and location (relative to existing ground level impervious surfaces and proposed development, including clearing and grading) on the plan set.

##### 5.2.2.1 Certified Arborist Report

A certified arborist report is required to obtain credits for stormwater mitigation. The arborist report must include the following information at a minimum:

- species of the tree(s) that are proposed for retention,
- condition of the tree(s) that are proposed for retention,
- verification that the proposed project will not negatively impact the tree(s).

##### 5.2.2.2 Tree Species and Condition

- Only trees contained in Appendix 7 of the Urban Forest Manual - The Approved Tree List - will be considered for tree credits. The Urban Forest Manual is available online at [www.cityoftacoma.org/UFM](http://www.cityoftacoma.org/UFM). Environmental Services may approve trees not contained on this list on a case-by-case basis. The applicant must submit growth characteristics (mature height and crown spread at maturity) for the proposed tree to the City. The growth characteristics must be obtained from a reputable source and must include information on mature height and width. Environmental Services will make the final determination of the flow credit for a given tree.
- Existing tree species and location must be clearly shown on submittal drawings.
- Trees must be viable for long-term retention (i.e., in good health and compatible with proposed construction).



### 5.2.2.3 Tree Size

To receive flow control credit, retained trees shall have a minimum 6 inches diameter at breast height (DBH). DBH is defined as the outside bark diameter at 4.5 feet above the ground on the uphill side of a tree (see Figure 3 - 12). For existing trees smaller than this, the newly planted tree credit may be applied as presented in Section 5.3.3.

The retained tree crown area shall be measured as the area within the tree drip line. A drip line is the line encircling the base of a tree, which is delineated by a vertical line extending from the outer limit of a tree's branch tips down to the ground (see Figure 3 - 13).

If trees are clustered, overlapping crowns are not double counted.

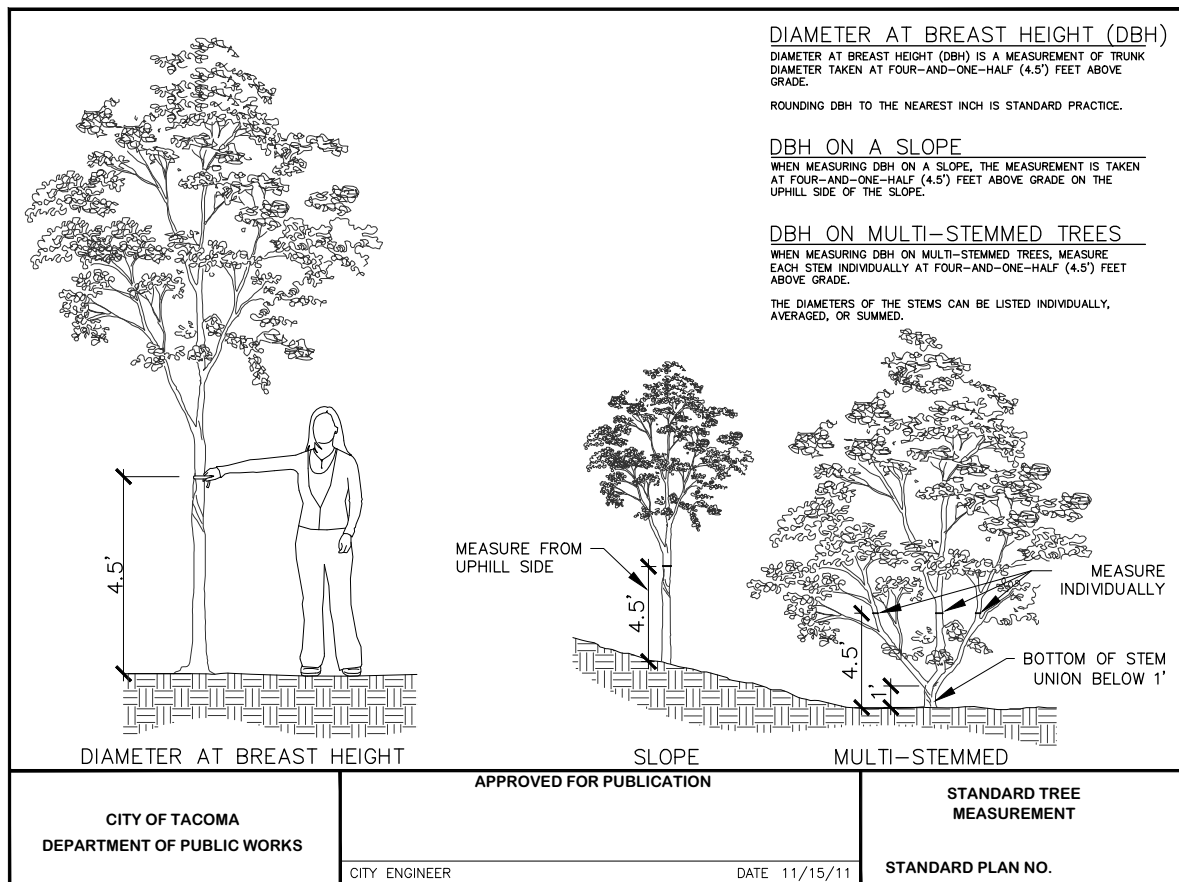


Figure 3 - 12. Standard Tree Measurement

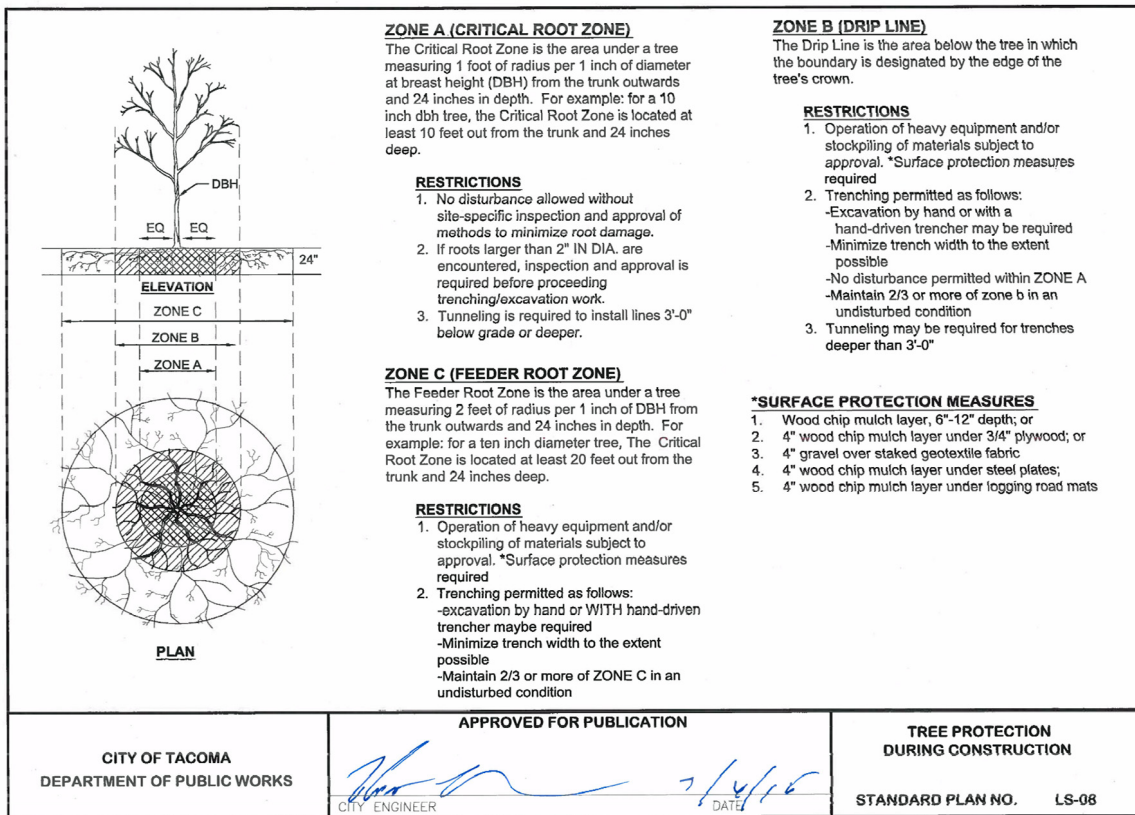


Figure 3 - 13. Tree Protection During Construction

**5.2.2.4 Tree Location**

Flow control credit for retained trees depends upon proximity to ground level impervious or other hard surfaces. To receive a credit, the existing tree must be on the project site and located within 20 feet of the ground level impervious or hard surface. Distance from impervious or other hard surfaces is measured from the tree trunk center.

If the arborist report concludes that impervious surface should not be placed within 20 feet of the tree and the crown overlap with impervious surface is still anticipated given a longer setback, higher tree flow control credit may be approved. Trees planted in planter boxes are not eligible for flow control credit.

**5.2.2.5 Tree Protection Measures during Construction**

The existing tree roots, trunk, and crown shall be fenced and protected during construction activities per Tacoma Municipal Code 9.18.030, according to industry standards (ANSI A300 Part 5) and the International Society of Arboriculture's Best Management Practices-Managing Trees During Construction.

**5.2.2.6 Long-term Tree Retention and Protection**

Trees shall be retained, maintained and protected on the site after construction and for the life of the development or until any approved redevelopment occurs in the future. Trees that are

removed or die shall be replaced with like species during the next planting season (typically October to March). Trees shall be pruned according to industry standards, ANSI A300 Part 1 and the International Society of Arboriculture’s Best Management Practices-Tree Pruning.

**5.2.3 Flow Control Credit**

Flow control credits for retained trees are provided in the table below:

**Table 3 - 6: Flow Credits for Retained Trees**

Tree Type	Credit	Minimum Square Footage Per Tree <sup>a</sup>
Evergreen	20% of Canopy Area	100 ft <sup>2</sup>
Deciduous	10% of Canopy Area	50 ft <sup>2</sup>

a. Only trees that produce the minimum square footage per tree can be used for credits

The total credits for retained and newly transplanted trees shall not exceed 25 percent of the total project impervious surface requiring mitigation. The total impervious or hard surface entered into the model may be reduced by the square footage mitigated but shall not exceed 25% of the total project impervious surface requiring mitigation.

The applicant will be required to enter into a covenant and easement agreement with the City to ensure the trees are properly maintained and will remain in place during their safe and useful life.

Flow credits only apply to flow control thresholds. Flow credits do not apply to water quality thresholds. Credits are given as a percentage of the existing tree canopy area.

To use these credits, the retained tree and protection measures must meet the requirements outlined in this section.

Tree credits are not applicable to trees in native vegetation areas used for flow dispersion or other flow control credit. The total tree credit for retained and newly transplanted trees shall not exceed 25 percent of the total project impervious surface requiring mitigation.

**5.3 Newly Transplanted Trees**

**5.3.1 Site Considerations**

Mature tree height, size, and rooting depth must be considered to ensure that the tree location is appropriate given adjacent and above- and below-ground infrastructure. Setback requirements are presented below. Setbacks are measured from the tree trunk center.

- Minimum 5 foot setback from structures
- Minimum 5 foot setback from underground utility lines
- Minimum 5 foot setback from property lines
- Minimum 2 foot setback from edge of any paved surface

**5.3.2 Design Criteria**

The following provides requirements and recommendations associated with tree transplanting for flow control credit. Submittal for review shall include the tree species, tree size (caliper or height), and tree location (with setbacks from ground level impervious surfaces structures and belowground utilities) on the plan set.

### 5.3.2.1 Tree Species

Only trees contained in Appendix 7 of the Urban Forest Manual - The Approved Tree List - will be considered for tree credits. The Urban Forest Manual is available online at [www.cityoftacoma.org/UFM](http://www.cityoftacoma.org/UFM). Environmental Services may approve trees not contained on this list on a case-by-case basis. The applicant must submit growth characteristics (mature height and crown spread at maturity) for the proposed tree to the City. The growth characteristics must be obtained from a reputable source and must include information on mature height and width. Environmental Services will make the final determination of the flow credit for a given tree.

### 5.3.2.2 Tree Size

To receive flow control credit, new deciduous trees shall be at least 1.5 inches in caliper measured 6 inches above the ground at the time of planting. New evergreen trees shall be at least 4 feet tall at the time of planting.

### 5.3.2.3 Tree Location

Trees shall be sited according to sun, soil, moisture, and species culture preference. Transplanting locations shall be selected to ensure that sight distances and appropriate setbacks are maintained given mature height, size, and rooting depths. Similar to retained trees, flow control credit for newly transplanted trees varies upon proximity to ground level impervious surfaces. To receive a credit, the newly transplanted tree must be on the project site and located within 20 feet of the ground level impervious or hard surface. Distance from impervious surfaces is measured from the edge of the surface to the center of the tree at ground level.

To help ensure tree survival and canopy coverage, the minimum tree spacing for newly transplanted trees shall accommodate mature tree spread. In no circumstance shall flow control credit be given for new trees transplanted less than 15 feet on center spacing for evergreen trees and 25 feet on center spacing for deciduous trees. Trees transplanted in above-ground structures (e.g. pots, planter boxes, etc.) are not eligible for flow control credit.

### 5.3.2.4 Irrigation

Provisions shall be made for supplemental irrigation during the first three growing seasons after installation to help ensure tree survival.

### 5.3.2.5 Long-term Tree Retention and Protection

Trees shall be retained, maintained and protected on the site after construction and for the life of the development as required for retained trees (Section 5.2).

## 5.3.3 Flow Control Credit

Flow control credits for newly transplanted trees are provided in the table below:

**Table 3 - 7: Flow Credits for Newly Transplanted Trees**

Tree Type	Credit
Evergreen	50 ft <sup>2</sup> per tree
Deciduous	20 ft <sup>2</sup> per tree

The credits provided in the table are square footage of impervious surface available for flow credit per tree. The total credits for retained and newly transplanted trees shall not exceed 25 percent of the total project impervious surface requiring mitigation. The total impervious or hard surface entered into the model may be reduced by the square footage mitigated but shall not exceed 25% of the total project impervious surface requiring mitigation.

The applicant will be required to enter into a covenant and easement agreement with the City to ensure the trees are properly maintained and will remain in place.

Flow credits only apply to flow control thresholds. Flow credits do not apply to water quality thresholds.

Tree credits are not applicable to trees in native vegetation areas used for flow dispersion or other flow control credit. The total tree credit for retained and newly planted trees shall not exceed 25 percent of impervious surface requiring mitigation.

## **5.4 Operations and Maintenance Requirements**

Operations and maintenance requirements for trees are provided in Volume 1, Appendix C, Checklist #30.

## **Chapter 6 Infiltration Facilities for Stormwater Flow Control**

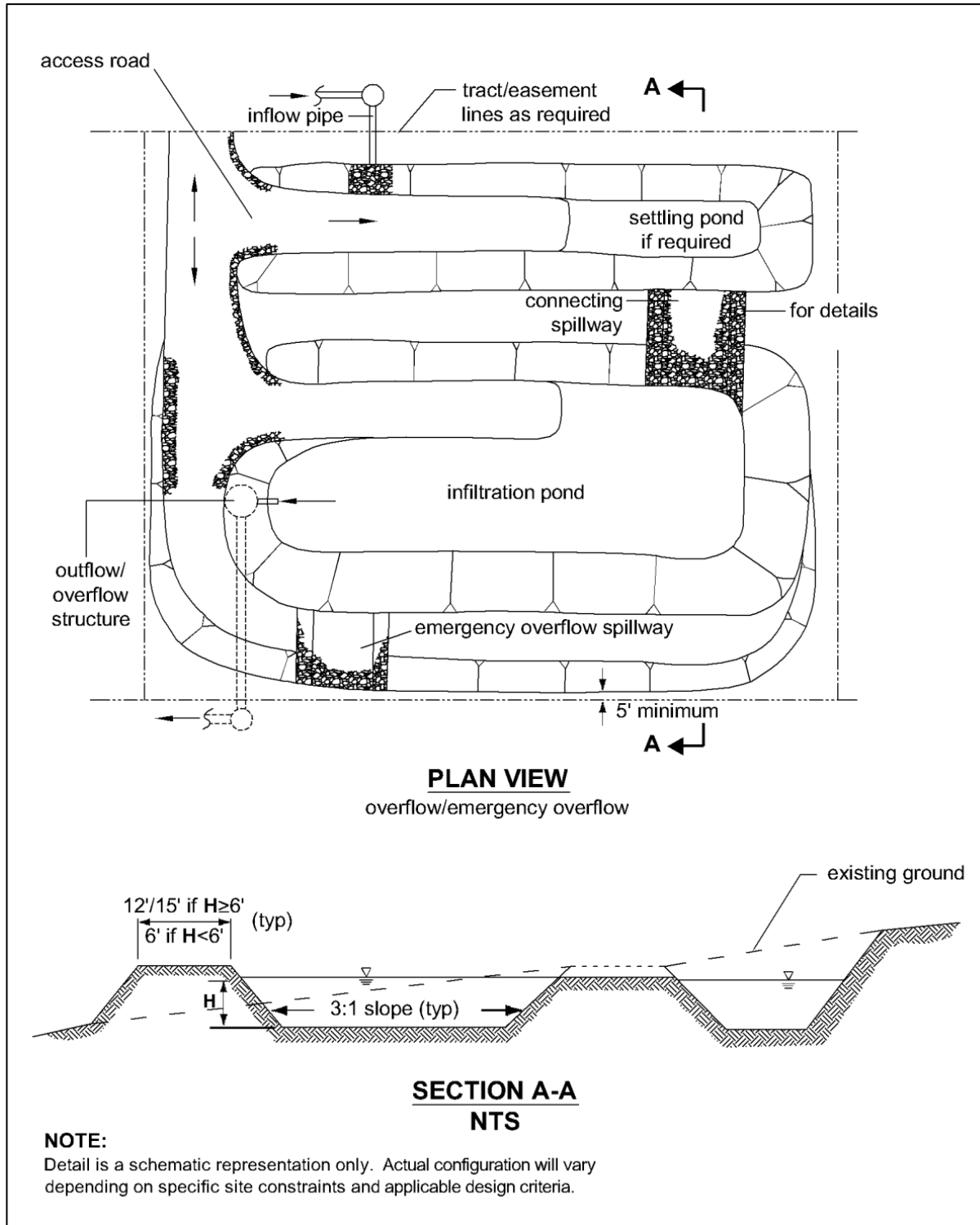
### **6.1 Purpose**

Infiltration provides onsite management of stormwater runoff. Infiltration facilities can be used for flow control and water quality purposes. Please see Volume 5, Chapter 5 for design criteria for water quality treatment.

### **6.2 Description**

An infiltration BMP is typically an open basin (pond), trench, or buried perforated pipe used for distributing the stormwater runoff into the underlying soil (See Figure 3 - 14). (See Underground Injection Control Program, Chapter 173-218 WAC).

This section highlights design criteria that are applicable to infiltration facilities serving a flow control function. See Volume 5, Chapter 5 for design criteria for treatment. See Volume 6 for design criteria for low impact development techniques. Certain low impact development techniques may also use infiltration as a means to provide stormwater flow control.



**Figure 3 - 14. Typical Infiltration Pond/Basin**

## **6.3 Design Methodology**

### **6.3.1 Select a location**

This will be based on the ability to convey flow to the location and the expected soil conditions of the location. Do a preliminary check of Site Suitability Criteria (Section 6.6) to estimate feasibility.

### **6.3.2 Estimate volume of stormwater, $V_{\text{design}}$**

Use WWHM to estimate the design volume.

### **6.3.3 Develop trial infiltration facility geometry**

To accomplish this, an infiltration rate will need to be assumed based on previously available data, or a default infiltration rate of 0.5 inches/hour can be used. This trial facility geometry should be used to help locate the facility and for planning purposes in developing the geotechnical subsurface investigation plan.

### **6.3.4 Complete a more detailed site characterization study and consider site suitability criteria**

Information gathered during initial geotechnical and surface investigations are necessary to know whether infiltration is feasible. The geotechnical investigation evaluates the suitability of the site for infiltration, establishes the infiltration rate for design, and evaluates slope stability, foundation capacity, and other geotechnical design information needed to design and assess constructability of the facility.

The site characterization study conditions shall be assessed by a qualified engineer with geotechnical experience, or a licensed geologist, hydrogeologist, or engineering geologist.

See Sections 6.4 and 6.6.

### **6.3.5 Determine the infiltration rate**

Methods for estimating the long-term infiltration rate are provided in Section 6.5.

### **6.3.6 Size the facility**

The size of the infiltration facility can be determined by routing the influent runoff file generated by WWHM through it. The primary mode of discharge from an infiltration facility is infiltration into the ground. However, when the infiltration capacity of the facility is reached, additional runoff to the facility will cause the facility to overflow. Overflows from an infiltration facility designed for flow control must comply with the Minimum Requirement #7.

**NOTE:** Infiltration facilities designed for flow control do not have a required drawdown time.

In order to determine compliance with the flow control requirements, the Western Washington Hydrology Model (WWHM) must be used.

#### ***(A) For 100% infiltration***

Using the output files from WWHM, ensure that the facility infiltrates 100% of the runoff file.



**(B) For 91% infiltration (water quality treatment volume)**

Using the output file from WWHM, ensure that the facility infiltrates 91% of the runoff file.

Infiltration facilities for treatment can be located upstream or downstream of detention and can be off-line or on-line.

- **On-line** treatment facilities placed **upstream or downstream** of a detention facility must be sized to infiltrate 91% of the runoff volume directed to it.
- **Off-line** treatment facilities placed **upstream** of a detention facility must have a flow splitter designed to send all flows at or below the 15-minute water quality flow rate, as predicted by WWHM to the treatment facility. The treatment facility must be sized to infiltrate all the runoff sent to it (no overflows from the treatment facility are allowed).
- **Off-line** treatment facilities placed **downstream** of a detention facility must have a flow splitter designed to send all flows at or below the 2-year flow frequency from the detention pond, as predicted by WWHM to the treatment facility. The treatment facility must be sized to infiltrate all the runoff sent to it (no overflows from the treatment facility are allowed).

See Volume 5, Section 5.1 for flow splitter design details.

**(C) To meet the flow duration standard**

Using the output files from WWHM, ensure that the total of any bypass and overflow from the facility meets the applicable flow control standard.

**(D) To meet the LID performance standard**

Using the output files from WWHM, ensure the total of any bypass and overflow from the facility meets the applicable LID performance standard.

**6.3.6.1 Drawdown Time**

There is no maximum drawdown time for infiltration facilities designed for flow control.

**6.3.7 Construction Criteria**

Initial basin excavation should be conducted to within 1-foot of the final elevation of the basin floor. Excavate infiltration trenches and basins to final grade only after all disturbed areas in the upgradient project drainage area have been permanently stabilized. The final phase of excavation should remove all accumulation of silt in the infiltration facility before putting it in service. After construction is completed, prevent sediment from entering the infiltration facility by first conveying the runoff water through an appropriate pretreatment system.

Infiltration facilities should generally not be used as temporary sediment traps during construction. If an infiltration facility is to be used as a sediment trap, it must not be excavated to final grade until after the upgradient drainage area has been stabilized. Any accumulation of silt in the basin must be removed before putting it in service.

Traffic Control – Relatively light-tracked equipment is recommended for use within infiltration areas for excavation and cleaning to avoid compaction of the basin floor. The use of draglines and trackhoes should be considered for constructing infiltration basins. The infiltration area should be flagged or marked to keep heavy equipment away.

### **6.3.8 Maintenance Criteria**

Per Minimum Requirement #9, an operation and maintenance plan shall be prepared for all stormwater management facilities. See Volume 1, Appendix C for specific maintenance requirements. Maintenance shall be a basic consideration in design and cost-determination of the stormwater management facility.

Any standing water removed during the maintenance operation must be disposed of in a City approved manner. See the dewatering requirements in Volume 4 of this manual. Pretreatment may be necessary. Solids must be disposed of in accordance with state and local waste regulations.

Facilities shall be designed and constructed such that the facility can be safely and easily inspected by one person and safely and easily maintained. This may require construction of additional inspection ports or access manholes to allow inspection access to be opened by one person.

### **6.3.9 Verification Testing of the Completed Facility**

Verification testing of the completed facility is recommended to demonstrate that the facility performs as designed. Use the same method for saturated hydraulic conductivity as used in the planning stages to ensure comparable results. Perform the testing after stabilizing the construction site. If the rates are lower than the design saturated hydraulic conductivity, the applicant shall implement measures to improve infiltration capability of the facility and retest. Replacement of the top foot of soil or more may be needed to ensure the facility performs as designed. Longer-term monitoring of the facility may be needed for some facilities. Environmental Services may require verification testing on a case-by-case basis.

## **6.4 Site Characterization Criteria**

One of the first steps in siting and designing infiltration facilities is to conduct a characterization study. Information gathered during initial geotechnical investigations can be used for the site characterization.

### **6.4.1 Surface Features Characterization**

- Topography within 500 feet of the proposed facility.
- Anticipated site use (street/highway, residential, commercial, high-use site).
- Location of water supply wells within 500 feet of proposed facility.
- Location of groundwater protection areas and/or 1, 5 and 10 year time of travel zones for municipal well protection areas.
- A description of local site geology, including soil or rock units likely to be encountered, the groundwater regime, and geologic history of the site.

### **6.4.2 Subsurface Characterization**

- See Volume 3, Appendix B for soils report requirements.
- Conduct pit/hole explorations between December 1 and March 31 to provide accurate groundwater saturation and groundwater information.

- Subsurface explorations (test holes or test pits) to a depth below the base of the infiltration facility of at least 5 times the maximum design depth of ponded water proposed for the infiltration facility, but not less than 10 feet.
- Continuous sampling (representative samples from each soil type and/or unit within the infiltration receptor) to a depth below the base of the infiltration facility of 2.5 times the maximum design ponded water depth, but not less than 10 feet.
- For basins, at least one test pit or test hole per 5,000 ft<sup>2</sup> of basin infiltrating surface (in no case less than two per basin).
- For trenches, at least one test pit or test hole per 200 feet of trench length (in no case less than two per trench).
- For large infiltration facilities serving drainage areas of 10 acres or more, perform soil grain size analyses on layers up to 50 feet deep or no more than 10 feet below the groundwater table.

The depth and number of test holes or test pits and samples should be increased, if in the judgment of a licensed engineer with geotechnical expertise (P.E.), a licensed geologist, engineering geologist, hydrogeologist, or other licensed professional acceptable to the City, the conditions are highly variable and such increases are necessary to accurately estimate the performance of the infiltration system. The exploration program may be decreased if, in the opinion of the licensed engineer or other professional, the conditions are relatively uniform and the borings/test pits omitted will not influence the design or successful operation of the facility. In high water table sites, the subsurface exploration sampling need not be conducted lower than two (2) feet below the groundwater table.

Prepare detailed logs for each test pit or test hole and a map showing the location of the test pits or test holes. Logs must include at a minimum, depth of pit or hole, soil descriptions, depth to water, and presence of stratification. Logs must substantiate whether stratification does or does not exist. The licensed professional may consider additional methods of analysis to substantiate the presence of stratification that will significantly impact the design of the infiltration facility.

### **6.4.3 Infiltration Rate Determination**

Determine the representative infiltration rate of the unsaturated vadose zone based on methods outlined in Section 6.5.

### **6.4.4 Infiltration Receptor**

The requirements of this section will be applied as directed by Environmental Services. Infiltration receptor (unsaturated and saturated soil receiving the stormwater) characterization should include:

- Installation of groundwater monitoring wells (at least three per infiltration facility, or three hydraulically connected surface and groundwater features that will establish a three-dimensional relationship for the groundwater table, unless the highest groundwater level is known to be at least 50 feet below the proposed infiltration facility) to:
  - Monitor the seasonal groundwater levels at the site during at least one wet season, and,
  - Consider the potential for both unconfined and confined aquifers, or confining units, at the site that may influence the proposed infiltration facility as well as the groundwater gradient. Other approaches to determine groundwater levels at the proposed site could be considered if pre-approved by Environmental Services, and

- Determine the ambient groundwater quality, if that is a concern.
- An estimate of the volumetric water holding capacity of the infiltration receptor soil. This is the soil layer below the infiltration facility and above the seasonal high-water mark, bedrock, hardpan, or other low permeability layer. This analysis should be conducted at a conservatively high infiltration rate based on vadose zone porosity, and the water quality runoff volume to be infiltrated. This, along with an analysis of groundwater movement, will be useful in determining if there are volumetric limitations that would adversely affect drawdown.
- Determination of:
  - Depth to groundwater table and to bedrock/impermeable layers
  - Seasonal variation of groundwater table based on well water levels and observed mottling
  - Existing groundwater flow direction and gradient
  - Lateral extent of infiltration receptor
  - Horizontal hydraulic conductivity of the saturated zone to assess the aquifer's ability to laterally transport the infiltrated water.
- Impact of the infiltration rate and volume at the project site on groundwater mounding, flow direction, and water table; and the discharge point or area of the infiltrating water. A groundwater mounding analysis should be conducted at all sites where the depth to seasonal groundwater table or low permeability stratum is less than 15 feet and the runoff to the infiltration facility is from more than one acre. (The site professional may consider conducting an aquifer test, or slug test to aid in determining the type of groundwater mounding analysis necessary at the site)

A detailed soils and hydrogeologic investigation should be conducted if potential pollutant impacts to groundwater are a concern, or if the applicant is proposing to infiltrate in areas underlain by till or other impermeable layers. (Suggested references: "Implementation Guidance for the Groundwater Quality Standards", Department of Ecology, publication 96-2, 2005).

## **6.5 Design Saturated Hydraulic Conductivity – Guidelines and Criteria**

Measured (initial) hydraulic saturated conductivity rates can be determined by one of the following three methods. The Soil Grain Size Analysis Method can only be used if the site soils are unconsolidated by glacial advance. See Volume 3, Appendix B to determine when it is necessary to obtain a design saturated hydraulic conductivity.

- Large Scale Pilot Infiltration Test (PIT) – Section 6.5.1
- Small Scale Pilot Infiltration Test (PIT) – Section 6.5.2
- Soil Grain Size Analysis Method – Section 6.5.3

### **6.5.1 Large Scale Pilot Infiltration Test (PIT)**

Large-scale in-situ infiltration measurements, using the Pilot Infiltration Test (PIT) described below is the preferred method for estimating the measured (initial) saturated hydraulic conductivity (K<sub>sat</sub>) of the soil profile beneath the proposed infiltration facility. The Large Scale PIT must be used when a Small Scale PIT per Volume 3, Section 6.5.2 or Soil Grain Size

Analysis Method per Volume 3, Section 6.5.3 cannot be used. The PIT reduces some of the scale errors associated with relatively small-scale double ring infiltrometer or “stove-pipe” infiltration tests. The large scale PIT is recommended as a practical field procedure by Ecology's Technical Advisory Committee

#### **6.5.1.1 Large Scale Pilot Infiltration Test Procedure**

- Excavate the test pit to the estimated surface elevation of the proposed infiltration facility. Lay back the slopes sufficiently to avoid caving and erosion during the test. Alternatively, consider shoring the sides of the test pit.
- The horizontal surface area of the bottom of the test pit should be approximately 100 square feet. Accurately document the size and geometry of the test pit.
- Install a vertical measuring rod (minimum 5-ft. long) marked in half-inch increments in the center of the pit bottom.
- Use a rigid 6-inch diameter pipe with a splash plate on the bottom to convey water to the pit and reduce side-wall erosion or excessive disturbance of the pond bottom. Excessive erosion and bottom disturbance will result in clogging of the infiltration receptor and yield lower than actual infiltration rates.
- Add water to the pit at a rate that will maintain a water level between 6 and 12 inches above the bottom of the pit. A rotameter can be used to measure the flow rate into the pit.

**NOTE:** Note: The depth should not exceed the proposed maximum depth of water expected in the completed facility. For infiltration facilities serving large drainage areas, designs with multiple feet of standing water can have infiltration tests with greater than 1 foot of standing water.

Every 15-30 min, record the cumulative volume and instantaneous flow rate in gallons per minute necessary to maintain the water level at the same point on the measuring rod.

Keep adding water to the pit until one hour after the flow rate into the pit has stabilized (constant flow rate; a goal of 5% variation or less variation in the total flow) while maintaining the same pond water level. The total of the pre-soak time plus one hour after the flow rate has stabilized should be no less than 6 hours.

- After the flow rate has stabilized for at least one hour, turn off the water and record the rate of infiltration (the drop rate of the standing water) in inches per hour from the measuring rod data, until the pit is empty. Consider running this falling head phase of the test several times to estimate the dependency of infiltration rate with head.
- At the conclusion of testing, over-excavate the pit to see if the test water is mounded on shallow restrictive layers or if it has continued to flow deep into the subsurface. The depth of excavation varies depending on soil type and depth to hydraulic restricting layer, and is determined by the engineer or certified soils professional. Mounding is an indication that a mounding analysis is necessary.

#### **6.5.1.2 Large Scale PIT Data Analysis**

Calculate and record the saturated hydraulic conductivity rate in inches per hour in 30 minutes or one-hour increments until one hour after the flow has stabilized.

**NOTE:** Note: Use statistical/trend analysis to obtain the hourly flow rate when the flow stabilizes. This would be the lowest hourly flow rate.

Apply appropriate correction factors per Volume 3, Section 6.5.4 to determine the site-specific design infiltration rate.

**Example**

The area of the bottom of the test pit is 8.5-ft. by 11.5-ft.

Water flow rate was measured and recorded at intervals ranging from 15 to 30 minutes throughout the test. Between 400 minutes and 1,000 minutes the flow rate stabilized between 10 and 12.5 gallons per minute or 600 to 750 gallons per hour, or an average of  $(9.8 + 12.3) / 2 = 11.1$  inches per hour.

**6.5.2 Small Scale Pilot Infiltration Test (PIT)**

A smaller-scale PIT can be substituted for the large-scale PIT in any of the following instances.

- The drainage area to the infiltration site is less than 1 acre.
- The testing is for the LID BMPs of bioretention or permeable pavement that either serve small drainage areas and /or are widely dispersed throughout a project site.
- The site has a high infiltration rate, making a full-scale PIT difficult, and the site geotechnical investigation suggests uniform subsurface characteristics.

**6.5.2.1 Small Scale Pilot Infiltration Test Procedure**

- Excavate the test pit to the estimated surface elevation of the proposed infiltration facility. In the case of bioretention, excavate to the estimated top elevation where the imported soil mix meets the underlying native soil. For permeable pavements, excavate to the elevation at which the imported subgrade materials, or the pavement itself, will contact the underlying native soil. If the native soils (road subgrade) will have to meet a minimum subgrade compaction requirement, compact the native soil to that requirement prior to testing. Note that the permeable pavement design guidance recommends compaction not exceed 90% - 92%. Finally, lay back the slopes sufficiently to avoid caving and erosion during the test. Alternatively, consider shoring the sides of the test pit.
- The horizontal surface area of the bottom of the test pit should be 12 to 32 square feet. It may be circular or rectangular, but accurately document the size and geometry of the test pit.
- Install a vertical measuring rod adequate to measure the ponded water depth and that is marked in half-inch increments in the center of the pit bottom.
- Use a rigid pipe with a splash plate on the bottom to convey water to the pit and reduce side-wall erosion or excessive disturbance of the pond bottom. Excessive erosion and bottom disturbance will result in clogging of the infiltration receptor and yield lower than actual infiltration rates. Use a 3 inch diameter pipe for pits on the smaller end of the recommended surface area, and a 4 inch pipe for pits on the larger end of the recommended surface area.
- Pre-soak period: Add water to the pit so that there is standing water for at least 6 hours. Maintain the pre-soak water level at least 12 inches above the bottom of the pit.
- At the end of the pre-soak period, add water to the pit at a rate that will maintain a 6-12 inch water level above the bottom of the pit over a full hour. The depth should not exceed the proposed maximum depth of water expected in the completed facility.
- Every 15 minutes, record the cumulative volume and instantaneous flow rate in gallons per minute necessary to maintain the water level at the same point (between 6 inches

and 1 foot) on the measuring rod. The specific depth should be the same as the maximum designed ponding depth (usually 6 – 12 inches).

- After one hour, turn off the water and record the rate of infiltration (the drop rate of the standing water) in inches per hour from the measuring rod data, until the pit is empty.
- A self-logging pressure sensor may also be used to determine water depth and drain-down.
- At the conclusion of testing, over-excavate the pit to see if the test water is mounded on shallow restrictive layers or if it has continued to flow deep into the subsurface. The depth of excavation varies depending on soil type and depth to hydraulic restricting layer, and is determined by the engineer or certified soils professional. The soils professional should judge whether a mounding analysis is necessary.

### 6.5.2.2 Small Scale PIT Data Analysis

Calculate and record the saturated hydraulic conductivity rate in inches per hour in 30 minutes or one-hour increments until one hour after the flow has stabilized.

**NOTE:** Note: Use statistical/trend analysis to obtain the hourly flow rate when the flow stabilizes. This would be the lowest hourly flow rate.

Apply appropriate correction factors per Volume 3, Section 6.5.4 to determine the site-specific design infiltration rate.

#### Example

The area of the bottom of the test pit is 8.5-ft. by 11.5-ft.

Water flow rate was measured and recorded at intervals ranging from 15 to 30 minutes throughout the test. Between 400 minutes and 1,000 minutes the flow rate stabilized between 10 and 12.5 gallons per minute or 600 to 750 gallons per hour, or an average of  $(9.8 + 12.3) / 2 = 11.1$  inches per hour.

### 6.5.3 Soil Grain Size Analysis Method

The Soil Grain Size Analysis Method can only be used if the site soils are unconsolidated by glacial advance. Most of the City of Tacoma is considered to be consolidated by glacial advance though there are some areas that contain alluvium deposits that may not be considered consolidated. The soils report must clearly state if this method is acceptable based upon the site specific soils analysis.

For each defined layer below the infiltration facility to a depth below the facility bottom of 2.5 times the maximum depth of water in the facility, but not less than 10 feet, estimate the saturated hydraulic conductivity in cm/sec using the following relationship (see Massmann 2003, and Massmann et al., 2003). For large infiltration facilities serving drainage areas of 10 acres or more, soil grain size analysis shall be performed on layers up to 50 feet deep (or no more than 10 feet below the water table).

$$\log_{10}(K_{sat}) = -1.57 + 1.90D_{10} + 0.015D_{60} - 0.013D_{90} - 2.08F_{finest} \quad (\text{equation 1})$$

Where,  $D_{10}$ ,  $D_{60}$  and  $D_{90}$  are the grain sizes in mm for which 10 percent, 60 percent and 90 percent of the sample is more fine and  $f_{finest}$  is the fraction of the soil (by weight) that passes the #200 sieve ( $K_{sat}$  is in cm/s).

For bioretention facilities, analyze each defined layer below the top of the final bioretention area subgrade to a depth of at least 3 times the maximum ponding depth, but not less than 3 feet (1 meter). For permeable pavement, analyze for each defined layer below the top of the final subgrade to a depth of at least 3 times the maximum ponding depth within the base course, but not less than 3 feet (1 meter).

If the licensed professional conducting the investigation determines that deeper layers will influence the rate of infiltration for the facility, soil layers at greater depths must be considered when assessing the site's hydraulic conductivity characteristics. Massmann (2003) indicates that where the water table is deep, soil or rock strata up to 100 feet below an infiltration facility can influence the rate of infiltration. Note that only the layers near and above the water table or low permeability zone (e.g., a clay, dense glacial till, or rock layer) need to be considered, as the layers below the groundwater table or low permeability zone do not significantly influence the rate of infiltration. Also note that this equation for estimating hydraulic conductivity assumes minimal compaction consistent with the use of tracked (i.e., low to moderate ground pressure) excavation equipment. If the soil layer being characterized has been exposed to heavy compaction, the hydraulic conductivity for the layer could be approximately an order of magnitude less than what would be estimated based on grain size characteristics alone (Pitt, 2003). In such cases, compaction effects must be taken into account when estimating hydraulic conductivity. For clean, uniformly graded sands and gravels, the reduction in  $K_{sat}$  due to compaction will be much less than an order of magnitude. For well-graded sands and gravels with moderate to high silt content, the reduction in  $K_{sat}$  will be close to an order of magnitude. For soils that contain clay, the reduction in  $K_{sat}$  could be greater than an order of magnitude.

If greater certainty is desired, the in-situ saturated conductivity of a specific layer can be obtained through the use of a pilot infiltration test (PIT). Note that these field tests generally provide a hydraulic conductivity combined with a hydraulic gradient. In some of these tests, the hydraulic gradient may be close to 1.0; therefore, in effect, the magnitude of the test result is the same as the hydraulic conductivity. In other cases, the hydraulic gradient may be close to the gradient that is likely to occur in the full-scale infiltration facility. The hydraulic gradient will need to be evaluated on a case-by-case basis when interpreting the results of field tests. It is important to recognize that the gradient in the test may not be the same as the gradient likely to occur in the full-scale infiltration facility in the long-term (i.e., when groundwater mounding is fully developed).

Once the saturated hydraulic conductivity for each layer has been identified, determine the effective average saturated hydraulic conductivity below the facility. Hydraulic conductivity estimates from different layers can be combined using the harmonic mean.

$$K_{equiv} = \frac{d}{\sum \frac{d_i}{K_i}} \quad (\text{equation 2})$$

Where,  $d$  is the total depth of the soil column,  $d_i$  is the thickness of layer " $i$ " in the soil column, and  $K_i$  is the saturated hydraulic conductivity of layer " $i$ " in the soil column. The depth of the soil column,  $d$ , typically would include all layers between the facility bottom and the water table. However, for sites with very deep water tables (>100 feet) where groundwater mounding to the base of the facility is not likely to occur, it is recommended that the total depth of the soil column in Equation 2 be limited to approximately 20 times the depth of facility, but not more than 50 ft.



This is to ensure that the most important and relevant layers are included in the hydraulic conductivity calculations. Deep layers that are not likely to affect the infiltration rate near the facility bottom should not be included in Equation 2. Equation 2 may over-estimate the effective hydraulic conductivity value at sites with low conductivity layers immediately beneath the infiltration facility. For sites where the lowest conductivity layer is within five feet of the base of the pond, it is suggested that this lowest hydraulic conductivity value be used as the equivalent hydraulic conductivity rather than the value from Equation 2. Using the layer with the lowest  $K_{sat}$  is advised for designing bioretention facilities or permeable pavements. The harmonic mean given by Equation 2 is the appropriate effective hydraulic conductivity for flow that is perpendicular to stratigraphic layers, and will produce conservative results when flow has a significant horizontal component such as could occur due to groundwater mounding.

### 6.5.4 Correction Factors

The hydraulic saturated conductivity obtained from the PIT test or Soil Grain Size Analysis Method is an initial rate. This initial rate shall be reduced through correction factors that are appropriate for the design situation to produce a design infiltration rate. Use the correction factors from Table 3-9 below or alternative values can be proposed based upon the professional judgment of the licensed engineer or site professional. Justification for alternate values must be provided to Environmental Services.

**Table 3 - 8: Measured Hydraulic Saturated Conductivity Rate Reduction Factors**

Issue	Partial Correction Factor
Site Variability and Number of Locations Tested	$CF_v = 0.33$ to $1.0$
Test Method	
• Large-Scale PIT	$CF_t = 0.75$
• Small-Scale PIT	$CF_t = 0.50$
• Grain Size Method	$CF_t = 0.40$
Siltation and Biofouling	$CF_m = 0.9$

Total Correction Factor,  $CF_T = CF_v \times CF_t \times CF_m$

$$K_{sat \text{ design}} = K_{sat \text{ initial}} * CF_T$$

#### 6.5.4.1 Site variability and number of locations tested ( $CF_v$ )

The number of locations tested must be capable of producing a picture of the subsurface conditions that fully represents the conditions throughout the facility site. The partial correction factor used for this issue depends on the level of uncertainty that adverse subsurface conditions may occur. If the range of uncertainty is low - for example, conditions are known to be uniform through previous exploration and site geological factors - one pilot infiltration test (or grain size analysis location) may be adequate to justify a partial correction factor at the high end of the range.

If the level of uncertainty is high, a partial correction factor near the low end of the range may be appropriate. This might be the case where the site conditions are highly variable due to conditions such as a deposit of ancient landslide debris, or buried stream channels. In these cases, even with many explorations and several pilot infiltration tests (or several grain size test locations), the level of uncertainty may still be high.

A partial correction factor near the low end of the range could be assigned where conditions have a more typical variability, but few explorations and only one pilot infiltration test (or one grain size analysis location) is conducted. That is, the number of explorations and tests conducted do not match the degree of site variability anticipated.

#### **6.5.4.2 Uncertainty of Test Method ( $CF_t$ )**

This correction factor accounts for uncertainties in the testing methods. These values are intended to represent the difference in each test's ability to estimate the actual saturated hydraulic conductivity. The assumption is the larger the scale of the test, the more reliable the result.

#### **6.5.4.3 Siltation and Biofouling ( $CF_m$ )**

Even with a presettling basin or a basic treatment facility for pretreatment, the soil's initial infiltration rate will gradually decline as more and more stormwater, with some amount of suspended material, passes through the soil profile. The maintenance schedule calls for removing sediment when the facility is infiltrating at only 90% of its design capacity. Therefore, a correction factor,  $CF_m$ , of 0.9 is called for.

## 6.6 Site Suitability Criteria

This section provides criteria that must be considered for siting infiltration systems. When a site investigation reveals that any of the applicable criteria cannot be met appropriate mitigation measures must be implemented so that the infiltration facility will not pose a threat to safety, health, and the environment.

For site selection and design decisions a geotechnical and hydrogeologic report must be prepared by a qualified engineer with geotechnical and hydrogeologic experience, or a licensed geologist, hydrogeologist, or engineering geologist. The design engineer may utilize a team of certified or registered professionals in soil science, hydrogeology, geology, and other related fields.

A site is not suitable if the infiltration facility will cause a violation of Ecology's Groundwater Quality Standards.

### 6.6.1 Setback Criteria

Typical setbacks are outlined in Section 6.7.1.

Below are conditions that the soils professional must evaluate to determine the need for additional or more stringent setbacks than outlined in this manual.

The professional must evaluate:

- Potential impacts to drinking water wells, septic tanks or drainfields, and springs used for public drinking water supplies.
- Potential impacts from roadways subject to deicers or herbicides which are likely to be present in the influent to the infiltration system.
- Potential impacts to all building foundations in the vicinity of the proposed infiltration facility. Investigate building foundations 100 feet or less upslope and 20 feet or less downslope from the proposed facility.
- Potential impacts to all property lines within 20 feet of the facility.
- Potential impacts to a Native Growth Protection Easement (NGPE);  $\geq 20$  feet.
- Potential impacts to slopes  $>15\%$  and within 50 feet.
- Onsite and offsite structural stability due to extended subgrade saturation and/or head loading of the permeable layers, including the potential impacts to downgradient properties, especially on hills with known side-hill seeps.

### 6.6.2 Groundwater Protection Areas

The City of Tacoma Public Works Department and Tacoma-Pierce County Health Department developed a guidance document that provides the circumstances and requirements for approval of infiltration facilities for managing pollution-generating stormwater runoff in the STGPD. The document, "Implementation of Stormwater Infiltration for Pollution-Generating Surfaces in the South Tacoma Groundwater Protection District" is available in Volume 5, Appendix D and online at [www.cityoftacoma.org/stormwater](http://www.cityoftacoma.org/stormwater).

### 6.6.3 High Vehicle Traffic Areas

An infiltration BMP may be considered for runoff from areas of industrial activity and the high vehicle traffic areas described below. For such applications, sufficient pollutant removal

(including oil removal) must be provided upstream of the infiltration facility to ensure that groundwater quality standards will not be violated and that the infiltration facility is not adversely affected.

High Vehicle Traffic Areas are:

- Commercial or industrial sites subject to an expected average daily traffic count (ADT)  $\geq 100$  vehicles/1,000 ft<sup>2</sup> gross building area (trip generation), and
- Road intersections with an ADT of  $\geq 25,000$  on the main roadway, or  $\geq 15,000$  on any intersecting roadway.

#### **6.6.4 Depth to Bedrock, Water Table, or Impermeable Layer**

The base of all infiltration basins or trench systems shall be  $\geq 5$  feet above the seasonal high-water mark, bedrock (or hardpan) or other low permeability layer. A 3-foot minimum separation may be considered if the groundwater mounding analysis, volumetric receptor capacity, and the design of the overflow and/or bypass structures are judged by the site professional and Environmental Services to be adequate to prevent overtopping and meet the site suitability criteria specified in this section.

#### **6.6.5 Seepage Analysis and Control**

Determine whether there would be any adverse effects caused by seepage zones on nearby building foundations, basements, roads, parking lots or sloping sites.

#### **6.6.6 Cold Climate and Impact of Roadway Deicers**

For cold climate design criteria (snowmelt/ice impacts) refer to D. Caraco and R. Claytor 'Stormwater BMPs Design Supplement for Cold Climates', Center for Watershed Protection, 1997.

Potential impact of roadway deicers on potable water wells must be considered in the siting determination. Mitigation measures must be implemented if infiltration of roadway deicers can cause a violation of groundwater quality standards.

### **6.7 Design Criteria for Infiltration Facilities**

#### **6.7.1 Infiltration Facility Setbacks**

Setback requirements are generally required by Tacoma Municipal Code, Uniform Building Code, the Tacoma Pierce County Health Department, or other state regulations. Where a conflict between setbacks occurs, the City shall require compliance with the most stringent of the setback requirements from the various codes/regulations. The following are the minimum setbacks required per this manual.

Additional setbacks may be required by other local, state, or federal agencies. See the individual BMPs for BMP specific setback criteria.

- At least 100 feet from drinking water wells, and springs used for public water supplies. Infiltration facilities upgradient of drinking water wells and within 1, 5, and 10-year time of travel zones must comply with Health Department requirements (Washington Wellhead Protection Program, DOH, Publication #331-018).
- All systems shall be at least 10 feet from any building structure and at least 5 feet from any other structure or property line unless approved in writing by Environmental Services.

If necessary, setbacks shall be increased from the minimum 10 feet in order to maintain a 1H:1V side slope for future excavation and maintenance. Vertical pond walls may necessitate an increase in setbacks.

- All facilities shall be a minimum of 50 feet from the top of any steep (greater than 15%) slope. A geotechnical analysis must be prepared addressing impacts to facilities proposed within 50 feet of a steep (greater than 15%) slope. More stringent setbacks may be required based upon other portions of Tacoma Municipal Code.
- At least 10 feet from septic tanks and septic drainfields. Shall not be located upstream of residential septic systems unless topography or a hydrologic analysis clearly indicates that subsurface flows will not impact the drainfield.
- Environmental Services may require additional setbacks or analysis for infiltration facilities proposed to be sited within the influence of known contaminated sites or abandoned landfills.

### **6.7.2 Pretreatment**

It is recommended to provide a pretreatment facility before stormwater enters the infiltration facility. Use either an option from the Basic Treatment Menu or from the Pretreatment Menu – see Volume 5.

A pretreatment facility will lower the influent suspended solids loading to the infiltration facility to allow longer maintenance intervals.

### **6.7.3 Infiltration Facility Access**

- The infiltration facility shall be easily accessible in order to perform necessary inspections and maintain the facility.
- Maintenance access road(s) shall be provided to the control structure and other drainage structures associated with the facility.
- Access roads/ramps must meet the following requirements:
  - Access roads may be constructed with an asphalt or gravel surface, or modular grid pavement.
  - Maximum grade shall be 15 percent.
  - Outside turning radius shall be a minimum of 40 feet.
  - Fence gates shall be located only on straight sections of road.
  - Access roads shall be 15 feet in width on curves and 12 feet on straight sections.
  - A driveway meeting City design standards must be provided where access roads connect to paved public roadways.
- If a fence is required, access shall be limited by a double-posted gate. If a fence is not required, access shall be limited by two fixed bollards on each side of the access road and two removable bollards equally located between the fixed bollards.
- Additional easements or modifications to proposed lot boundaries may be required to provide adequate access to stormwater facilities. Right-of-way may be needed for facility maintenance. Any tract not abutting public right-of-way shall have a 15-foot wide extension of the tract to an acceptable access location.

#### **6.7.4 Infiltration Facility Overflow**

Provide for a primary overflow designed to bypass the 100-year, 24-hour developed peak flowrate or 100-year return period flowrate as estimated by WWHM. The design must provide controlled discharge to a location acceptable to Environmental Services.

#### **6.7.5 Infiltration Facility Seeps and Springs**

Intermittent seeps along cut slopes are typically fed by a shallow groundwater source (interflow) flowing along a relatively impermeable soil stratum. These flows are storm driven. However, more continuous seeps and springs, which extend through longer dry periods, are likely from a deeper groundwater source. When continuous flows are intercepted and directed through infiltration facilities, adjustments to the facility design shall be made to account for the additional base flow. Flow monitoring of intercepted flow may be required for design purposes.

#### **6.7.6 Infiltration Facility Construction Criteria**

Construct the facility in a way that does not compact the infiltration facility and does not cause siltation in the bottom of the facility. On a case-by-case basis, the City may require a specific construction schedule be supplied to ensure the infiltration facility will function appropriately when brought online. The following practices are recommended:

- Excavate to within one foot of the final elevation of the basin floor. Excavate to final grade only after all disturbed areas have been permanently stabilized. The final phase of excavation should remove any accumulation of fine particles before putting the facility into service.
- Do not use infiltration facilities as temporary sediment traps or ponds during construction.
- Keep heavy equipment away from excavated infiltration facility area.

#### **6.7.7 Infiltration Facility Maintenance**

Per Minimum Requirement #9, an operation and maintenance plan shall be prepared for all stormwater management facilities. See Volume 1, Appendix C for specific maintenance requirements. Maintenance shall be a basic consideration in design and cost-determination of the stormwater management facility.

Any standing water removed during the maintenance operation must be disposed of in a City approved manner. See the dewatering requirements in Volume 4 of this manual. Pretreatment may be necessary. Solids must be disposed in accordance with state and local waste regulations.

Facilities shall be designed and constructed such that the facility can be safely and easily inspected by one person and safely and easily maintained. This may require construction of additional inspection ports or access manholes to allow inspection access to be opened by one person.

#### **6.7.8 Infiltration Facility Easements**

See Chapter 13 for information concerning easements.

### **6.8 Infiltration Basins**

This section covers design and maintenance criteria specific for infiltration basins. See schematic in Figure 3 - 14.

### **6.8.1 Description**

Infiltration basins are earthen impoundments used for the collection, temporary storage and infiltration of incoming stormwater runoff.

### **6.8.2 Design Criteria Specific for Basins**

- Access should be provided for vehicles to easily maintain the forebay (presettling basin) area and not disturb vegetation, or resuspend sediment any more than is absolutely necessary.
- The slope of the basin bottom should not exceed 3% in any direction.
- A minimum of one foot of freeboard is recommended when establishing the design ponded water depth. Freeboard is measured from the rim of the infiltration facility to the maximum ponding level or from the rim down to the overflow point if overflow or a spillway is included.
- Erosion protection of inflow points to the basin must also be provided (e.g., riprap, flow spreaders, energy dissipators (See Volume 3, Chapter 3). Select suitable vegetative materials for the basin floor and side slopes to be stabilized. Refer to Volume 5, Chapter 7 for recommended vegetation.
- Lining material – Basins can be open or covered with a 6 to 12-inch layer of filter material such as coarse sand, or a suitable filter fabric to help prevent the buildup of impervious deposits on the soil surface. A nonwoven geotextile should be selected that will function sufficiently without plugging (see geotextile specifications in Appendix B of Volume 5). The filter layer can be replaced or cleaned when/if it becomes clogged.
- Vegetation – The embankment, emergency spillways, spoil and borrow areas, and other disturbed areas should be stabilized and planted, preferably with grass, in accordance with the Stormwater Site Plan (See Minimum Requirement #1 of Volume 1). Without healthy vegetation the surface soil pores would quickly plug.
- Ponds shall have a sign placed for maximum visibility from adjacent streets, sidewalks, and paths. An example and specifications for ponds is provided in Section 7.2.2.9; Figure 3 - 18 and Table 3 - 9.

## **6.9 Infiltration Trenches**

This section covers design, construction and maintenance criteria specific to infiltration trenches.

### **6.9.1 Description**

Infiltration trenches are generally at least 24 inches wide, and are backfilled with a coarse stone aggregate, allowing for temporary storage of stormwater runoff in the voids of the aggregate material. Stored runoff then gradually infiltrates into the surrounding soil. The surface of the trench can be covered with grating and/or consist of stone, gabion, sand, or a grassed covered area with a surface inlet. Perforated rigid pipe is used to distribute the stormwater in the stone trench.

### **6.9.2 Design Criteria**

Due to accessibility and maintenance limitations, infiltration trenches must be carefully designed and constructed.

Infiltration trenches may be placed in fill material if the fill is placed and compacted under the direct supervision of a geotechnical engineer or professional civil engineer with geotechnical expertise, and if the measured infiltration rate is at least 8 inches per hour.

The base of the infiltration facility shall be level.

#### **6.9.2.1 Cleanouts/Access Ports**

Install cleanouts and/or access ports to allow cleaning and inspection of the system.

#### **6.9.2.2 Backfill Material**

The aggregate material for the infiltration trench shall consist of a clean aggregate with a maximum diameter of 3 inches and a minimum diameter of 1.5 inches. Void space for these aggregates shall be in the range of 30 to 40 percent.

#### **6.9.2.3 Geotextile Fabric Liner**

Non-woven geotextile fabric shall be placed over the trench aggregate prior to backfilling. To help ensure no migration of native soil into the rock layer, a 6-inch minimum layer of sand may be used as a filter media at the bottom of the trench below the washed rock layer. Volume 5, Appendix B contains specifications for geotextile fabric.

#### **6.9.2.4 Overflow Channel**

Because an infiltration trench is generally used for small drainage areas, an emergency spillway is not necessary. However, a non-erosive overflow channel leading to a stabilized watercourse or other Environmental Services approved location should be provided.

#### **6.9.2.5 Surface Cover**

A stone filled trench can be placed under a porous or impervious surface cover to conserve space.

#### **6.9.2.6 Observation Well**

An observation well should be installed at the lower end of the infiltration trench to check water levels, drawdown time, sediment accumulation, and conduct water quality monitoring. City of Tacoma Standard Plan GSI-02 (see Volume 6, Appendix B) (which is also City of Tacoma Standard Plan GSI-02 available at [www.govme.org](http://www.govme.org) under the Standard Plan Tab) illustrates observation well details. It should consist of a perforated PVC pipe which is 4 to 6 inches in diameter and it should be constructed flush with the ground elevation. For larger trenches, a 12-36 inch diameter well can be installed to facilitate maintenance operations such as pumping out the sediment. The top of the well should be capped to discourage vandalism and tampering.

#### **6.9.2.7 Pipe**

- Distribution pipe shall be level and shall be either perforated or slotted pipe.
- Perforated pipe shall conform to WSDOT specification 9-05.2.
- Slotted pipe shall have slots cut perpendicular to the long axis of the pipe and be 0.04 to 0.069 inches by 1 inch long and be spaced 0.25 inches apart longitudinally.
- Distribution pipe shall be a minimum of 8 inches in diameter.



### **6.9.3 Construction Criteria**

#### **6.9.3.1 Trench Preparation**

Excavated materials must be placed away from the trench sides to enhance trench wall stability. Care should also be taken to keep this material away from slopes, neighboring property, sidewalks and streets. It is recommended that this material be covered with plastic. (see Volume 2, Chapter 3, BMP C123: Plastic Covering). Place geotextile fabric liner prior to stone aggregate placement.

#### **6.9.3.2 Stone Aggregate Placement and Compaction**

The stone aggregate should be placed in lifts and compacted using plate compactors. As a rule of thumb, a maximum loose lift thickness of 12 inches is recommended. The compaction process ensures geotextile conformity to the excavation sides, thereby reducing potential piping and geotextile clogging, and settlement problems.

#### **6.9.3.3 Potential Contamination**

Prevent natural or fill soils from intermixing with the stone aggregate. All contaminated stone aggregate shall be removed and replaced with uncontaminated stone aggregate.

#### **6.9.3.4 Overlapping and Covering**

Following the stone aggregate placement, the geotextile must be folded over the stone aggregate to form a 12 inch minimum longitudinal overlap. When overlaps are required between rolls, the upstream roll should overlap a minimum of 2 feet over the downstream roll in order to provide a shingled effect.

#### **6.9.3.5 Voids behind Geotextile**

Voids between the geotextile and excavation sides must be avoided. Removing boulders or other obstacles from the trench walls is one source of such voids. Natural soils should be placed in these voids at the most convenient time during construction to ensure geotextile conformity to the excavation sides. Soil piping, geotextile clogging, and possible surface subsidence will be avoided by this remedial process.

#### **6.9.3.6 Unstable Excavation Sites**

Vertically excavated walls may be difficult to maintain in areas where the soil moisture is high or where soft or cohesionless soils predominate. Trapezoidal, rather than rectangular, cross-sections may be needed.

## **Chapter 7 Detention Facilities for Stormwater Flow Control**

This section presents the methods, criteria, and details for design and analysis of detention facilities. These facilities provide for the temporary storage of increased stormwater runoff resulting from development pursuant to the performance standards set forth in Minimum Requirement #7 for flow control (Volume 1).

There are three primary types of detention facilities described in this section: detention ponds, tanks, and vaults.

### **7.1 Detention Facility Design Criteria**

#### **7.1.1 Detention Facility Setbacks**

Setback requirements are generally required by Tacoma Municipal Code, Uniform Building Code, the Tacoma Pierce County Health Department, or other state regulations. Where a conflict between setbacks occurs, the City shall require compliance with the most stringent of the setback requirements from the various codes/regulations. The following are the minimum setbacks required per this manual.

Additional setbacks may be required by other local, state, or federal agencies. See the individual BMPs for BMP specific setback criteria.

- At least 100 feet from drinking water wells, and springs used for public water supplies. Infiltration facilities upgradient of drinking water wells and within 1, 5, and 10-year time of travel zones must comply with Health Department requirements (Washington Wellhead Protection Program, DOH, Publication #331-018).
- All systems shall be at least 10 feet from any building structure and at least 5 feet from any other structure or property line unless approved in writing by Environmental Services. If necessary, setbacks shall be increased from the minimum 10 feet in order to maintain a 1H:1V side slope for future excavation and maintenance. Vertical pond walls may necessitate an increase in setbacks.
- All facilities shall be a minimum of 50 feet from the top of any steep (greater than 15%) slope. A geotechnical analysis must be prepared addressing impacts to facilities proposed within 50 feet of a steep (greater than 15%) slope. More stringent setbacks may be required based upon other portions of Tacoma Municipal Code.
- The discharge point shall not be placed on slopes steeper than 20 percent. A geotechnical analysis and report shall be required on slopes over 15% or if located within 200 feet of the top of steep slopes (40% or greater) or a landslide hazard area. More stringent setbacks may be required based upon the Tacoma Municipal Code.
- At least 10 feet from septic tanks and septic drainfields. Shall not be located upstream of residential septic systems unless topography or a hydrologic analysis clearly indicates that subsurface flows will not impact the drainfield.
- Environmental Services may require additional setbacks or analysis for facilities proposed to be sited within the influence of known contaminated sites or abandoned landfills.

### **7.1.2 Detention Facility Access**

- The detention facility shall be easily accessible in order to perform necessary inspections and maintain the facility.
- Maintenance access road(s) shall be provided to the control structure and other drainage structures associated with the facility.
- Access roads/ramps must meet the following requirements:
  - Access roads may be constructed with an asphalt or gravel surface, or modular grid pavement.
  - Maximum grade shall be 15 percent.
  - Outside turning radius shall be a minimum of 40 feet.
  - Fence gates shall be located only on straight sections of road.
  - Access roads shall be 15 feet in width on curves and 12 feet on straight sections.
  - A driveway meeting City design standards must be provided where access roads connect to paved public roadways.
- If a fence is required, access shall be limited by a double-posted gate. If a fence is not required, access shall be limited by two fixed bollards on each side of the access road and two removable bollards equally located between the fixed bollards.
- Additional easements or modifications to proposed lot boundaries may be required to provide adequate access to detention facilities. Right-of-way may be needed for detention pond maintenance. Any tract not abutting public right-of-way shall have a 15-foot wide extension of the tract to an acceptable access location.

### **7.1.3 Detention Facility Overflow**

In all ponds, tanks, and vaults, a primary overflow (usually a riser pipe within the control structure; see Section 7.5) shall be provided to bypass the 100-year, 24-hour developed peak flowrate or the 100-year return period flowrate as estimated by WWHM, over or around the restrictor system. The design must provide controlled discharge directly into the downstream conveyance system.

### **7.1.4 Detention Facility Seeps and Springs**

Intermittent seeps along cut slopes are typically fed by a shallow groundwater source (interflow) flowing along a relatively impermeable soil stratum. These flows are storm driven. However, more continuous seeps and springs, which extend through longer dry periods, are likely from a deeper groundwater source. When continuous flows are intercepted and directed through flow control facilities, adjustments to the facility design shall be made to account for the additional base flow. Flow monitoring of intercepted flow may be required for design purposes.

### **7.1.5 Detention Facility Maintenance**

Per Minimum Requirement #9, an operation and maintenance plan shall be prepared for all stormwater management facilities. See Volume 1, Appendix C for specific maintenance requirements. Maintenance shall be a basic consideration in design and cost-determination of the stormwater management facility.

Any standing water removed during the maintenance operation must be disposed of in a City approved manner. See the dewatering requirements in Volume 4, Appendix D of this manual.

Pretreatment may be necessary. Solids must be disposed in accordance with state and local waste regulations.

Facilities shall be designed and constructed such that the facility can be safely and easily inspected by one person and safely and easily maintained. This may require construction of additional inspection ports or access manholes to allow inspection access to be opened by one person.

### **7.1.6 Detention Facility Easements**

See Chapter 13 for information concerning easements.

## **7.2 Detention Ponds**

The design criteria in this section are for detention ponds. However, many of the criteria also apply to infiltration ponds (Chapter 6 and Volume 5), and water quality wetponds and combined detention/wetponds (Volume 5).

### **7.2.1 Dam Safety for Detention Ponds**

Stormwater detention facilities that can impound 10 acre-feet (435,600 cubic feet; 3.26 million gallons) or more above normal, surrounding grade with the water level at the embankment crest are subject to Ecology's dam safety requirements, even if water storage is intermittent and infrequent (WAC 173-175-020). The principal safety concern is for the downstream population at risk if the dam should breach and allow an uncontrolled release of the pond contents. Peak flows from dam failures are typically much larger than the 100-year flows which these ponds are typically designed to accommodate. The Applicant shall contact Ecology's Dam Safety Engineers at Ecology Headquarters if any of these conditions are met.

### **7.2.2 Design Criteria Specific for Detention Ponds**

Standard details for detention ponds are provided in Figure 3 - 15 through Figure 3 - 18 and Table 3 - 9. Control structure discussion and details are provided in Section 7.5.

#### **7.2.2.1 General**

- Ponds must be designed as flow-through systems (however, parking lot storage may utilize a back-up system; see Chapter 8). Developed flows must enter through a conveyance system separate from the control structure and outflow conveyance system. Maximizing distance between the inlet and outlet is encouraged to promote sedimentation.
- Pond bottoms shall be level and be located a minimum of 0.5 feet below the inlet and outlet to provide sediment storage.
- Design criteria for outflow control structures are specified in Section 7.5.
- A geotechnical analysis and report must be prepared for slopes 20% or greater, or if located within 200 feet of the top of a slope 20% or greater or landslide hazard area. The scope of the geotechnical report shall include the assessment of impoundment seepage on the stability of the natural slope where the facility will be located within the setback limits set forth in this section.

#### **7.2.2.2 Setbacks**

The following setback requirements shall be met, along with those stipulated in Section 7.1.1.

- The 100-year water surface elevation shall be at least 10 feet from any building structure and at least 5 feet from any other structure or property line unless approved in writing by Environmental Services. If necessary, setbacks shall be increased from the minimum 10 feet in order to maintain a 1H:1V side slope for future excavation and maintenance. Vertical pond walls may necessitate an increase in setbacks.

### **7.2.2.3 Side Slopes**

- Interior side slopes up to the emergency overflow water surface shall not be steeper than 3H:1V unless a fence is provided (see Section 7.2.2.8).
- Exterior side slopes must not be steeper than 2H:1V unless analyzed for stability by a geotechnical engineer.
- Pond walls may be vertical retaining walls, provided:
  - They are constructed of minimum 3,000 psi structural reinforced concrete.
  - A fence is provided along the top of the wall.
  - At least 25% of the pond perimeter shall be a vegetated soil slope not steeper than 3H:1V.
  - Access for maintenance per this section shall be provided.
  - The design is stamped by a licensed structural engineer or civil engineer with structural expertise.
  - Ladders shall be provided on the walls for safety reasons as required by Environmental Services.

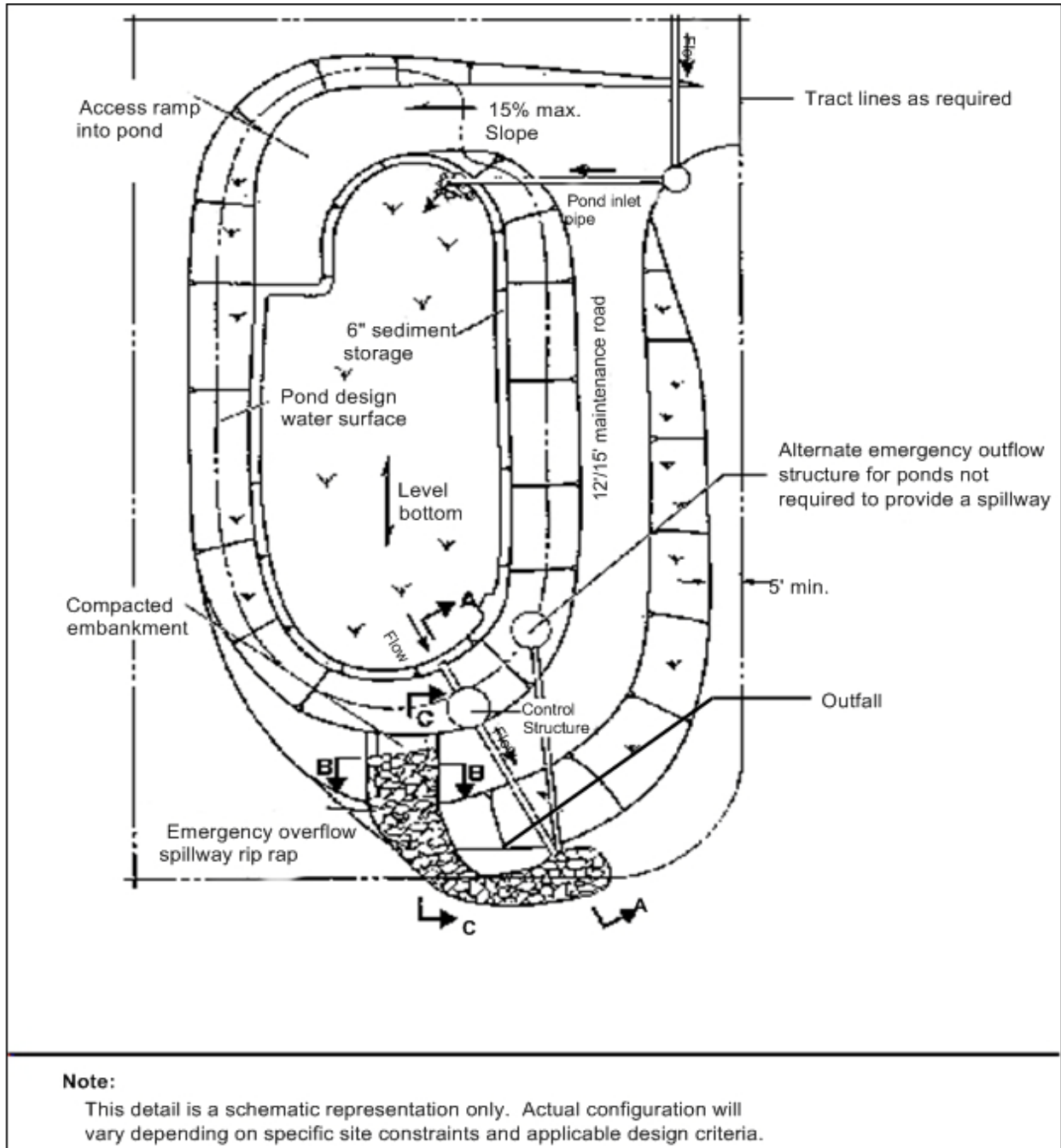
Other retaining walls such as rockeries, concrete, masonry unit walls, and keystone type walls may be used if designed by a geotechnical engineer, structural engineer, or civil engineer with structural expertise.

### **7.2.2.4 Embankments**

- Pond berm embankments higher than 6 feet must be designed by a professional engineer with geotechnical expertise.
- For berm embankments 6 feet or less in height, the minimum top width shall be 6 feet or as recommended by a geotechnical engineer.
- Pond berm embankments must be constructed on native consolidated soil (or adequately compacted and stable fill soils analyzed by a geotechnical engineer) free of loose surface soil materials, roots, and other organic debris.
- Pond berm embankments greater than 4 feet in height must be constructed by excavating a key equal to 50 percent of the berm embankment cross-sectional height and width unless specified otherwise by a geotechnical engineer.
- Embankment compaction should be accomplished in such a manner as to produce a dense, low permeability engineered fill that can tolerate post-construction settlements with a minimum of cracking. The embankment fill shall be placed on a stable subgrade and compacted to a minimum of 95% of the Standard Proctor Maximum Density, ASTM Procedure D698. Placement moisture content should lie within 1% dry to 3% wet of the optimum moisture content.
- The berm embankment shall be constructed of soils with the following minimum characteristics per the United States Department of Agriculture's Textural Triangle: a minimum of 20% silt and clay, a maximum of 60% sand, a maximum of 60% silt, with

nominal gravel and cobble content. Soils outside this range may be used by stamped recommendation of geotechnical engineer.

- Anti-seepage filter-drain diaphragms must be placed on all pipes in berm embankments impounding water with depths greater than 8 feet at the design water surface. See Dam Safety Guidelines, Part IV, Section 3.3.B. An electronic version of Dam Safety Guidelines is available in PDF format at [www.ecy.wa.gov/programs/wr/dams/dss.html](http://www.ecy.wa.gov/programs/wr/dams/dss.html)



**Figure 3 - 15. Typical Detention Pond**

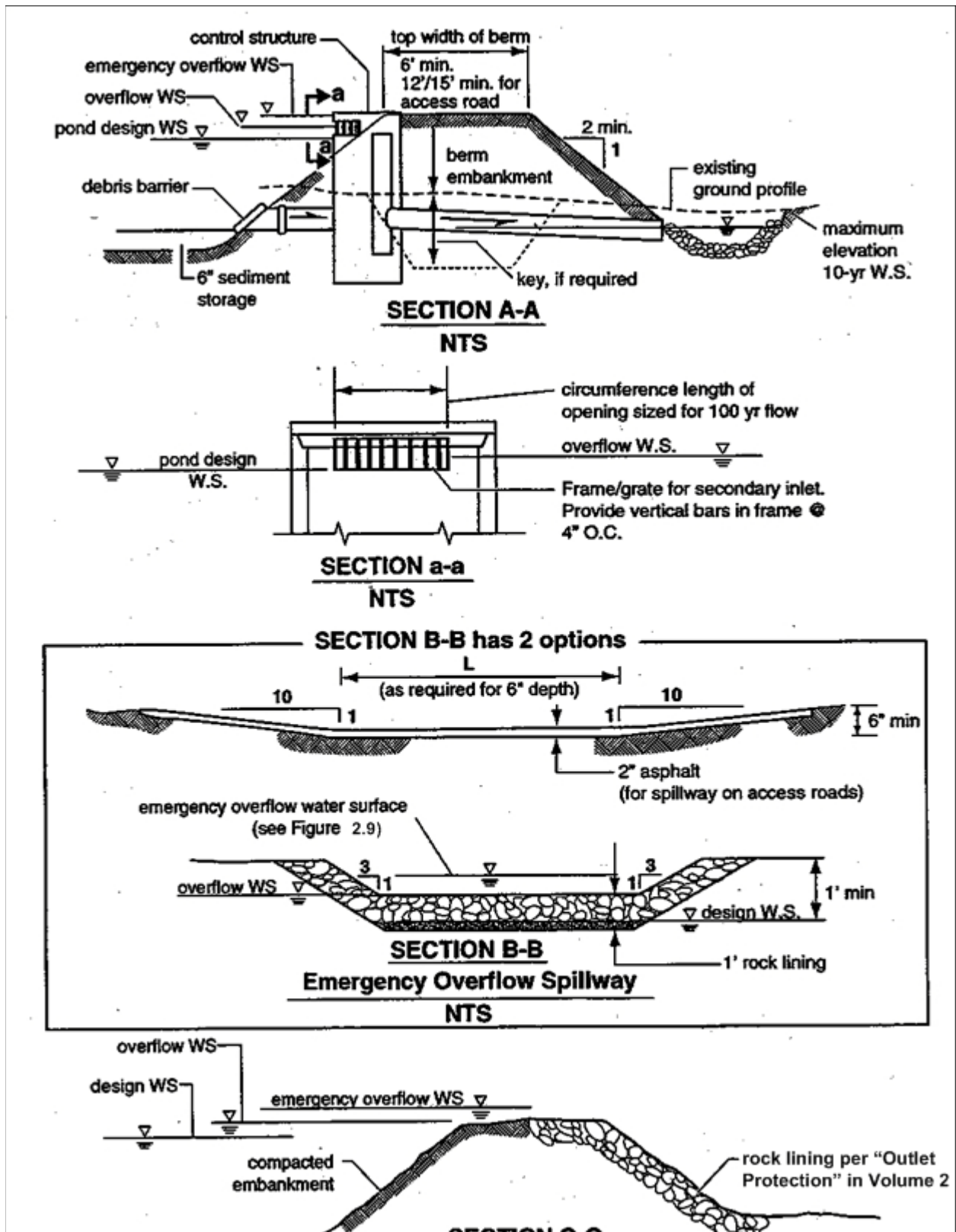
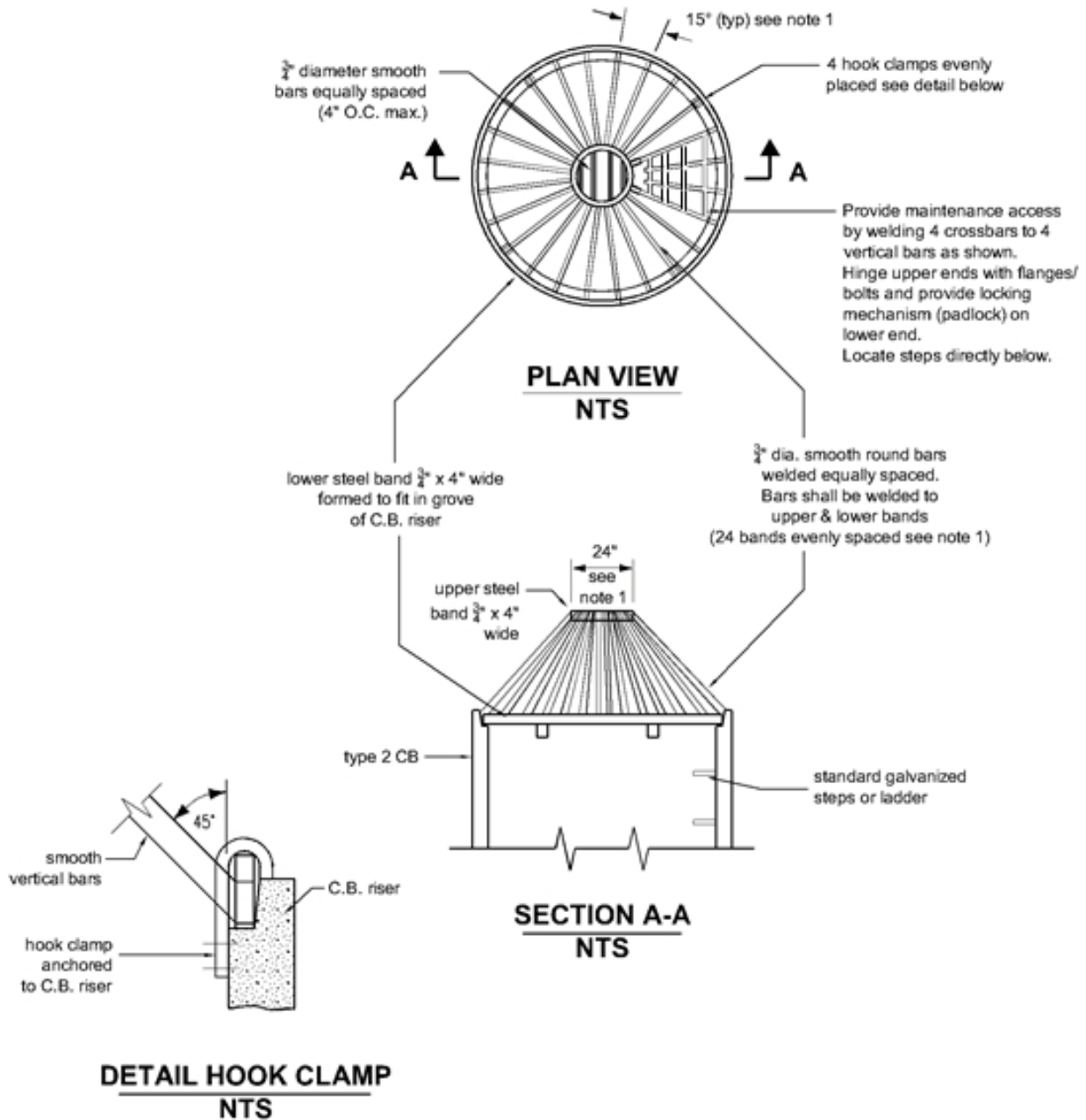


Figure 3 - 16. Typical Detention Pond Sections



**NOTES:**

1. Dimensions are for illustration on 54" diameter CB. For different diameter CB's adjust to maintain 45° angle on "vertical" bars and 7" o.c. maximum spacing of bars around lower steel band.
2. Metal parts must be corrosion resistant; steel bars must be galvanized.
3. This debris barrier is also recommended for use on the inlet to roadway cross-culverts with high potential for debris collection (except on type 2 streams)

**Figure 3 - 17. Overflow Structure**

**7.2.2.5 Overflow**

The following overflow requirements shall be met along with those stipulated in Section 7.1.3.

- A secondary inlet to the control structure shall be provided in ponds as additional protection against overtopping should the inlet pipe to the control structure become



plugged. A grated opening (“jailhouse window”) in the control structure manhole functions as a weir (see Figure 3 - 16) when used as a secondary inlet.

- The maximum circumferential length of this opening must not exceed one-half the control structure circumference.
- The “birdcage” overflow structure as shown in Figure 3 - 17 may also be used as a secondary inlet.

#### **7.2.2.6 Emergency Overflow Spillway**

- In addition to the above overflow provisions, ponds shall have an emergency overflow spillway. For impoundments of 10 acre-feet or greater, the emergency overflow spillway must meet the state’s dam safety requirements (see above). For impoundments less than 10 acre-feet, ponds must have an emergency overflow spillway that is sized to pass the 100-year, 24-hour developed peak flowrate or 100-year return period flowrate as estimated by WWHM. Emergency overflow spillways shall control the location of pond overtopping such that flow is directed into the downstream conveyance system or public right of way.
- As an option for ponds with berms less than 2 feet in height and located at grades less than 5 percent, emergency overflow may be provided by an emergency overflow structure, such as a Type II manhole fitted with a birdcage as shown in Figure 3 - 17. The emergency overflow structure must be designed to pass the 100-year, 24-hour developed peak flowrate or 100-year return period flowrate as estimated using WWHM, with a minimum of 6 inches of freeboard, directly to the downstream conveyance system or another acceptable discharge point.
- The emergency overflow spillway shall be armored with riprap in conformance with the “Outlet Protection” BMP in Volume 2 (BMP C209). The spillway must be armored full width, beginning at a point midway across the berm embankment and extending downstream to where emergency overflows re-enter the conveyance system (See Figure 3 - 16).
- Emergency overflow spillway designs must be analyzed as broad-crested trapezoidal weirs as described in Methods of Analysis at the end of this section. Either one of the weir sections shown in Figure 3 - 16 may be used.
- Where an emergency overflow spillway will discharge to a slope steeper than 15%, consideration should be given to providing an emergency overflow structure in addition to the spillway. Additional geotechnical analysis may be required.

#### **7.2.2.7 Access**

The following access requirements shall be met along with those stipulated in Section 7.1.2:

- An access ramp is required for pond cleaning and maintenance. The ramp must extend to the pond bottom with a maximum slope of 15 percent (see access road criteria in Section 7.1.2).
- The internal berm of the pond may be used for access if all the following apply:
  - The internal berm is no more than 4 feet above the first wetpool cell.
  - The first wetpool cell is less than 1,500 square feet (measured without the ramp).
  - The internal berm is designed to support a loaded truck, considering the berm is normally submerged and saturated.
- Access ramps shall meet the requirements for design of access roads.
- If fencing is required, access should be limited by a gate or bollards.

### 7.2.2.8 Fencing

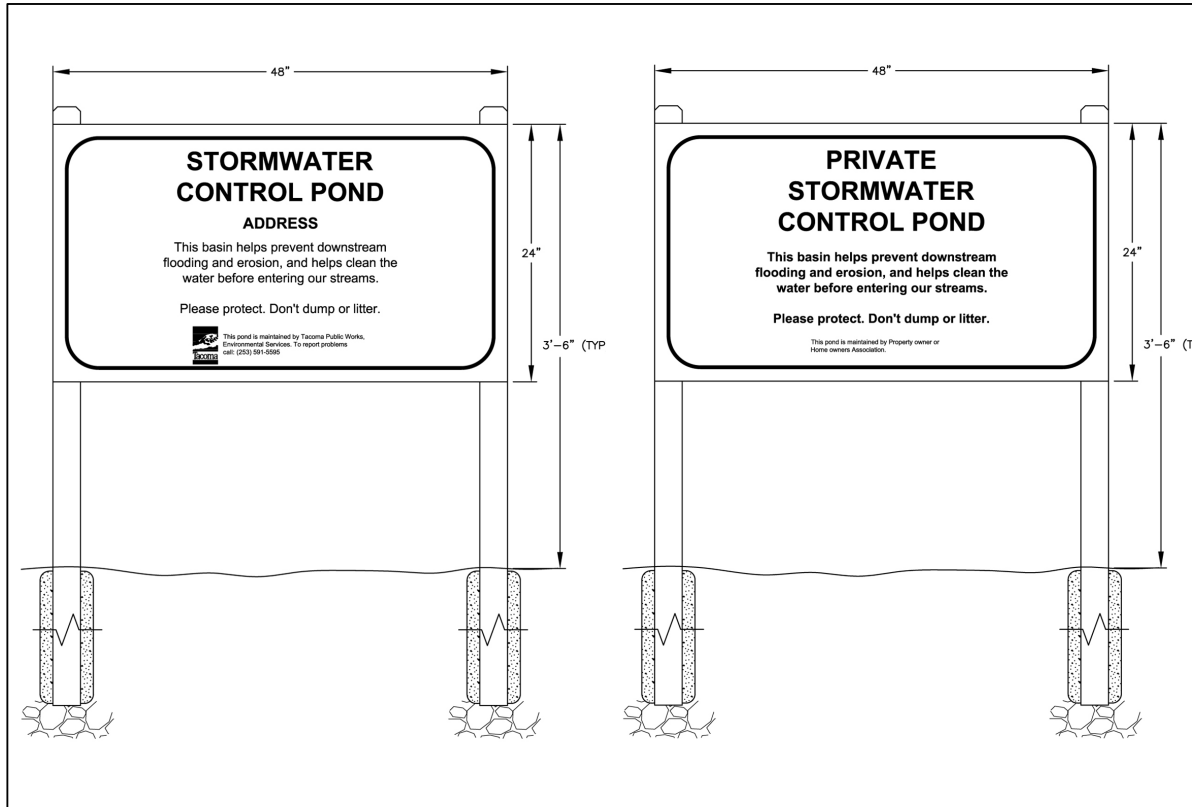
- A fence is required when a pond interior side slope is steeper than 3H:1V, or when the impoundment is a wall greater than 24 inches in height. Fencing is required for all vertical walls. Fencing is required if more than 10 percent of slopes are steeper 3H:1V.

Also note that detention ponds on school sites shall comply with safety standards developed by the Department of Health (DOH) and the Superintendent for Public Instruction (SPI). These standards include what is called a 'non-climbable fence.'

- Fences shall be 6 feet in height (see WSDOT Standard Plan L-2, Type 1 or Type 3 chain link fence). The fence may be a minimum of 4 feet in height if the depth of the impoundment is 5 feet or less (see WSDOT Standard Plan L-2, Type 4 or Type 6 chain link fence).
- Access gates shall be 16 feet in width consisting of two swinging sections 8 feet in width.
- Vertical metal balusters or 9 gauge galvanized steel fabric with bonded vinyl coating shall be used as fence material with the following aesthetic features:
  - Vinyl coating shall be compatible with the surrounding environment (e.g., green in open grassy areas and black or brown in wooded areas). All posts, cross bars, and gates shall be painted or coated the same color as the vinyl clad fence fabric.
  - Fence posts and rails shall conform to WSDOT Standard Plan L-2 for Types 1, 3, or 4 chain link fence.
- For metal baluster fences, Uniform Building Code standards apply.
- Wood fences may be used in residential areas where the fence will be maintained by homeowners associations or adjacent lot owners.
- Wood fences shall have pressure treated posts (ground contact rated) either set in 24-inch deep concrete footings or attached to footings by galvanized brackets. Rails and fence boards may be cedar, pressure-treated fir, or hemlock.

### 7.2.2.9 Signage

Detention ponds shall have a sign placed for maximum visibility from adjacent streets, sidewalks, and paths. An example pond sign and example specifications for a permanent stormwater control pond are provided in Figure 3 - 18 and Table 3 - 9.



**Figure 3 - 18. Examples of Permanent Stormwater Control Pond Sign**

**Table 3 - 9: Example Permanent Stormwater Control Pond Sign Specifications**

<b>Size</b>	48 inches by 24 inches
<b>Material</b>	0.125 gauge aluminum
<b>Face</b>	Non-reflective vinyl or 3 coats outdoor enamel (sprayed)
<b>Lettering</b>	Silk-screen enamel where possible, or vinyl letters
<b>Colors</b>	Per City specifications where required
<b>Type Face</b>	Helvetica condensed. Title: 3 inch; Sub-Title: 1-1/2 inch; Text: 1 inch;
<b>Border</b>	Outer 1/8-inch border distance from edge: 1/4 inch All text shall be at least 1-3/4 inches from border.
<b>Installation</b>	Secure to chain link fence if available. Otherwise install on two posts as described below. Top of sign no higher than 42 inches from ground surface.
<b>Posts</b>	Pressure-treated 4" x 4"; beveled tops 1-1/2 inches higher than the top of the sign; mounted atop gravel bed, installed in 30-inch concrete-filled post holes (8-inch minimum diameter)
<b>Placement</b>	Face sign in direction of primary visual or physical access. Do not block any access road. Do not place within 6 feet of structural facilities (e.g. manholes, spillways, pipe inlets).
<b>Special Notes</b>	This facility is lined.

### 7.2.2.10 Planting Requirements

Exposed earth on the pond bottom and interior side slopes shall be sodded or seeded with an appropriate seed mixture or landscaped. All remaining areas of the tract shall be planted with grass or be landscaped and mulched with a 4-inch cover of hog fuel or shredded wood mulch. Shredded wood mulch is made from shredded tree trimmings, usually from trees cleared on site. The mulch should be free of garbage and weeds and should not contain excessive resin, tannin, or other material detrimental to plant growth. Multiple plantings and mulching may be required until vegetation has established itself. A bond may be required to guarantee vegetation stabilization for detention facilities. The seed mix and coverage shall be specified on the plan set.

### 7.2.2.11 Landscaping

Landscaping is encouraged for most stormwater tract areas (see below for areas not to be landscaped). However, if provided, landscaping should adhere to the criteria that follow so as not to hinder maintenance operations. Landscaped stormwater tracts may, in some instances, provide a recreational space. In other instances, “naturalistic” stormwater facilities may be placed in open space tracts.

The following guidelines shall be followed if landscaping is proposed for facilities.

- Provide a planting plan that clearly shows the species of plants and the spacing for each plant species.
- No trees or shrubs shall be planted on berms meeting the criteria for dams regulated for safety.
- No trees or shrubs shall be planted within 10 feet of inlet or outlet pipes or manmade drainage structures such as spillways or flow spreaders.
- Species of trees with roots that seek water shall be avoided within 50 feet of pipes or manmade structures.
- Planting shall be restricted on berms that impound water either permanently or temporarily during storms. This restriction does not apply to cut slopes that form pond banks, only to berms.
  - Trees or shrubs may not be planted on portions of water-impounding berms taller than four feet high. Only grasses may be planted on berms taller than four feet.
  - Trees planted on portions of water-impounding berms less than 4 feet high must be small, not higher than 20 feet mature height, and must have a fibrous root system. Table 3 - 10 gives some examples of trees with these characteristics developed for the Central Puget Sound.

**NOTE:** The internal berm in a wetpond is not subject to this planting restriction since the failure of an internal berm would be unlikely to create a safety problem.

- All landscape material, including grass, shall be planted in topsoil. Topsoil shall be tilled in or otherwise integrated into the detention pond bottom or sides to ensure proper plant growth. If a liner is present, this may require additional consideration to ensure liner depth is maintained. Native underlying soils may be made suitable for planting if amended with 4 inches of compost tilled into the subgrade. Compost shall:
  - Meet the definition for “composted material” per WAC 173-350-100 and comply with standards in WAC 173-350-220, except the feedstock may contain biosolids or manure feedstocks.
  - Have no visible water or dust during handling.

- Have soil organic matter content of 40% to 65%.
- Have a carbon to nitrogen ratio below 25:1. Carbon to nitrogen ratio may be as high as 35:1 for plantings composed entirely of plants native to the Puget Sound Lowlands region.

Compost specifications can also be found in Volume 5, Appendix E.

- For a naturalistic effect as well as ease of maintenance, trees or shrubs shall be planted in clumps to form “*landscape islands*” rather than planting evenly spaced.
  - The landscaped islands shall be a minimum of six feet apart, and if set back from fences or other barriers, the setback distance should also be a minimum of 6 feet. Where tree foliage extends low to the ground, the 6 feet setback should be counted from the outer drip line of the trees (estimated at maturity).
  - This setback allows a 6-foot wide mower to pass around and between clumps.
- Evergreen trees and trees which produce relatively little leaf-fall are preferred in areas draining to the pond.
- Trees should be set back so that branches do not extend over the pond (to prevent deposition of leaves into the pond).
- Drought tolerant species are recommended.

**Table 3 - 10: Small Trees and Shrubs with Fibrous Roots**

Small Trees/High Shrubs	Low Shrubs
Red twig dogwood ( <i>Cornus stolonifera</i> )*	Snowberry ( <i>Symphoricarpus albus</i> )*
Serviceberry ( <i>Amelanchier alnifolia</i> )*	Salmonberry ( <i>Rubus spectabilis</i> )*
Filbert ( <i>Corylus cornuta</i> , others)*	Rock rose ( <i>Cistus spp.</i> , <i>Ceanothus spp.</i> , choose hardier varieties)
Highbush cranberry ( <i>Vaccinium opulus</i> )	New Zealand flax ( <i>Phormium tenax</i> )
Blueberry ( <i>Vaccinium spp.</i> )	Ornamental grasses (e.g. <i>Miscanthis</i> , <i>Pennisetum</i> )
Fruit trees on dwarf rootstock	Native Rose ( <i>R. gymnocarpa</i> , <i>R. Piscocarpa</i> , <i>R. nutkana</i> , etc)*
Rhododendron (native and ornamental varieties)*	
Shore pine ( <i>Pinus Contorta</i> var. <i>Contortz</i> )*	
Mountain hemlock ( <i>Tsuga mertensiana</i> )*	
Chokecherry ( <i>Prunus virginiana</i> )*	

\* Native Species

### 7.2.3 Methods of Analysis

#### 7.2.3.1 Detention Volume and Outflow

The volume and outflow design for detention ponds must be in accordance with Minimum Requirements # 7 in Volume 1 and the hydrologic analysis and design methods in Chapter 1 of Volume 3. Design guidelines for restrictor orifice structures are given in Section 7.5.

The design water surface elevation is the highest elevation which occurs in order to meet the required outflow performance for the pond.

**7.2.3.2 Detention Ponds in Infiltrative Soils**

Detention ponds may occasionally be sited on soils that are sufficiently permeable for a properly functioning infiltration system (see Chapter 6). These detention ponds have a surface discharge and may also utilize infiltration as a second pond outflow. Detention ponds sized with infiltration as a second outflow must meet all the requirements of Chapter 6 for infiltration ponds, including a soils report, testing, groundwater protection, pre-settling, and construction techniques.

**7.2.3.3 Emergency Overflow Spillway Capacity**

For impoundments under 10-acre-feet, or ponds not subject to dam safety requirements, the emergency overflow spillway weir section must be designed to pass the 100-year runoff event for developed conditions assuming a broad-crested weir. The **broad-crested weir equation** for the spillway section in Figure 3 - 19, for example, would be:

$$Q_{100} = C(2g)^{1/2} \left[ \frac{2}{3}LH^{3/2} + \frac{8}{15}(\tan\theta)H^{5/2} \right] \quad \text{(equation 1)}$$

- Where  $Q_{100}$  = flow for the 100-year runoff event (cfs)
- $C$  = discharge coefficient (0.6)
- $g$  = gravity (32.2 ft/sec<sup>2</sup>)
- $L$  = length of weir (ft)
- $H$  = height of water over weir (ft)
- $\theta$  = angle of side slopes (degrees)

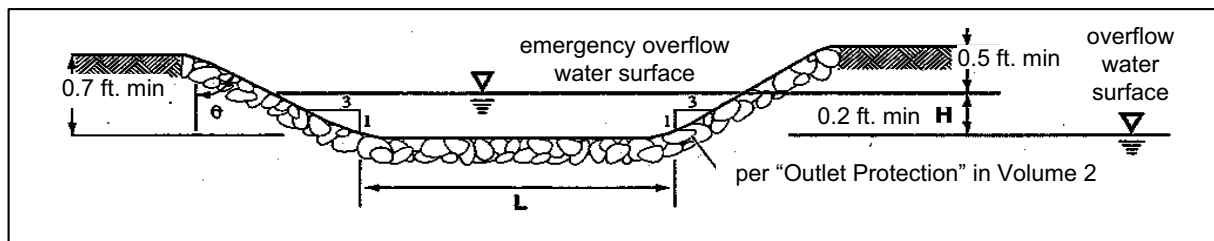
**NOTE:**  $Q_{100}$  is either the peak 10-minute flow computed from the 100-year, 24-hour storm and a Type 1A distribution, or the 100-year return period flowrate as estimated by WWHM.

Assuming  $C = 0.6$  and  $\tan \theta = 3$  (for 3:1 slopes), the equation becomes:

$$Q_{100} = 3.21[LH^{3/2} + 2.4 H^{5/2}] \quad \text{(equation 2)}$$

To find width  $L$  for the weir section, the equation is rearranged to use the computed  $Q_{100}$  and trial values of  $H$  (0.2 feet minimum):

$$L = [Q_{100}/(3.21H^{3/2})] - 2.4 H \text{ or } 6 \text{ feet minimum} \quad \text{(equation 3)}$$



**Figure 3 - 19. Weir Section for Emergency Overflow Spillway**

### 7.3 Detention Tanks

Detention tanks are underground storage facilities typically constructed with large diameter pipe. Standard detention tank details are shown in Figure 3 - 20 and Figure 3 - 21. Control structure details are shown in Section 7.5.

Certain of these requirements and design criteria shall also apply to other types of detention facilities, for example arch pipe detention facilities. Environmental Services shall determine which requirements and design criteria are appropriate for various types of detention facilities.

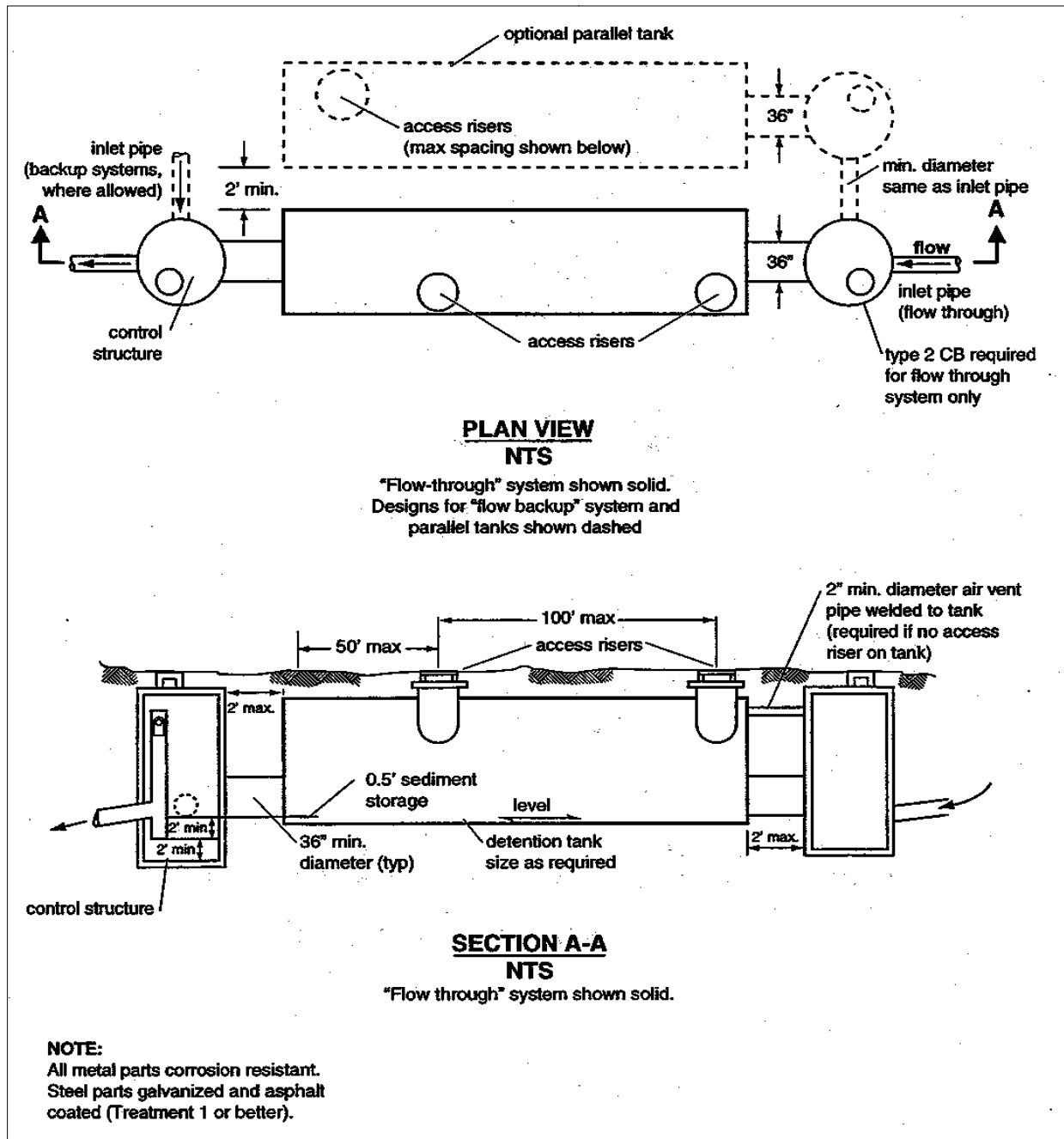


Figure 3 - 20. Typical Detention Tank

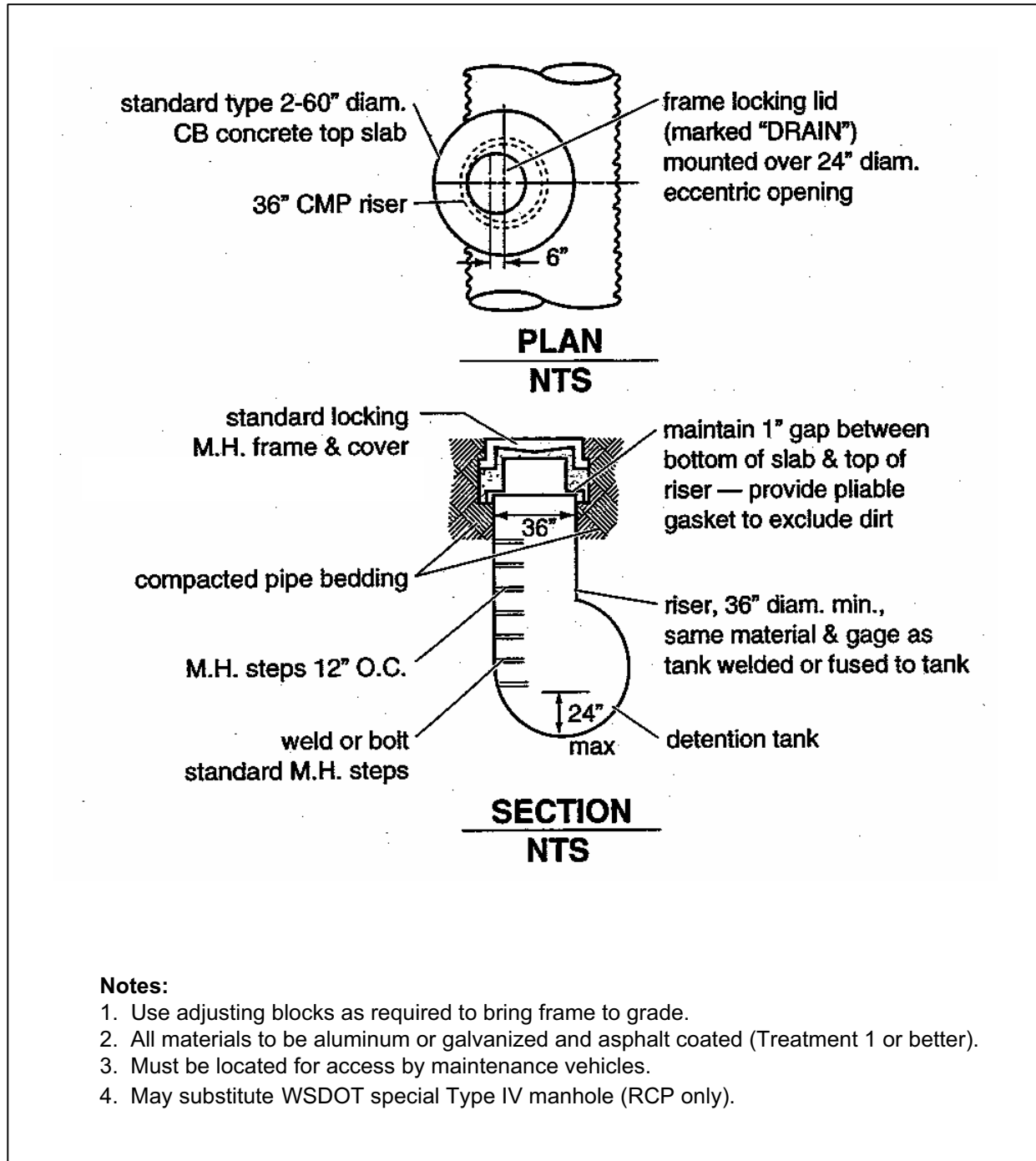


Figure 3 - 21. Detention Tank Access Detail



## **7.3.1 Design Criteria**

### **7.3.1.1 General**

- Tanks shall be designed as flow-through systems with manholes in line (see Figure 3 - 20) to promote sediment removal and facilitate maintenance.
- The detention tank bottom shall be located 6 inches below the inlet and outlet to provide dead storage for sediment. If arch pipe is used, the minimum dead storage is 0.5 feet.
- The minimum pipe diameter for a detention tank is 36 inches.
- The minimum thickness for CMP shall be 12-gauge.
- Tanks larger than 36 inches may be connected to each adjoining structure with a short section (2-foot maximum length) of 36-inch minimum diameter pipe. These sections shall not be considered as access when determining required access points.
- Details of outflow control structures are given in Section 7.5.
- Parallel tanks shall be placed a minimum of two feet from each other measured from the edge of tank or pipe.

### **7.3.1.2 Materials**

Acceptable materials for stormwater facilities include plastics, iron, aluminum, stainless steel, and concrete. Zinc galvanized materials are prohibited. Galvanized metal pipes may only be used if they employ a protective asphalt coating. Pipe material, joints, and protective treatment for tanks shall be in accordance with Section 9.05 of the *WSDOT/APWA Standard Specification*.

### **7.3.1.3 Structural Stability**

Tanks must meet structural requirements for overburden support and traffic loading if appropriate. Tanks must be designed for H-20 live loads when located in areas subject to vehicular traffic. Metal tank end plates shall be designed for structural stability at maximum hydrostatic loading conditions. Tanks shall not be placed in fill slopes, unless analyzed in a geotechnical report for stability and constructability.

### **7.3.1.4 Buoyancy**

Buoyancy calculations shall be required where groundwater may induce flotation. Engineers are required to address this issue in project design documentation.

### **7.3.1.5 Access**

The following requirements for access shall be met along with those stipulated in Section 7.1.2.

- The maximum depth from finished grade to tank invert shall be 20 feet.
- Access openings shall be positioned a maximum of 50 feet from any location within the tank. A minimum of one access opening per tank shall be provided.
- The maximum distance between access risers shall be 100 feet.
- All tank access openings shall have round, solid locking lids (usually 1/2 to 5/8-inch diameter Allen-head cap screws).
- Thirty-six inch minimum diameter CMP riser-type manholes (see Figure 3 - 21) of the same gauge as the tank material may be used for access along the length of the tank and at the upstream terminus of the tank in a backup system. The top slab is separated (1-inch minimum gap) from the top of the riser to allow for deflections from vehicle loadings without damaging the riser tank.

- All tank access openings must be readily accessible to maintenance vehicles.
- Tanks must comply with the OSHA confined space requirements, which include clearly marking entrances to confined space areas. This may be accomplished by hanging a removable sign in the access riser(s) just under the access lid.

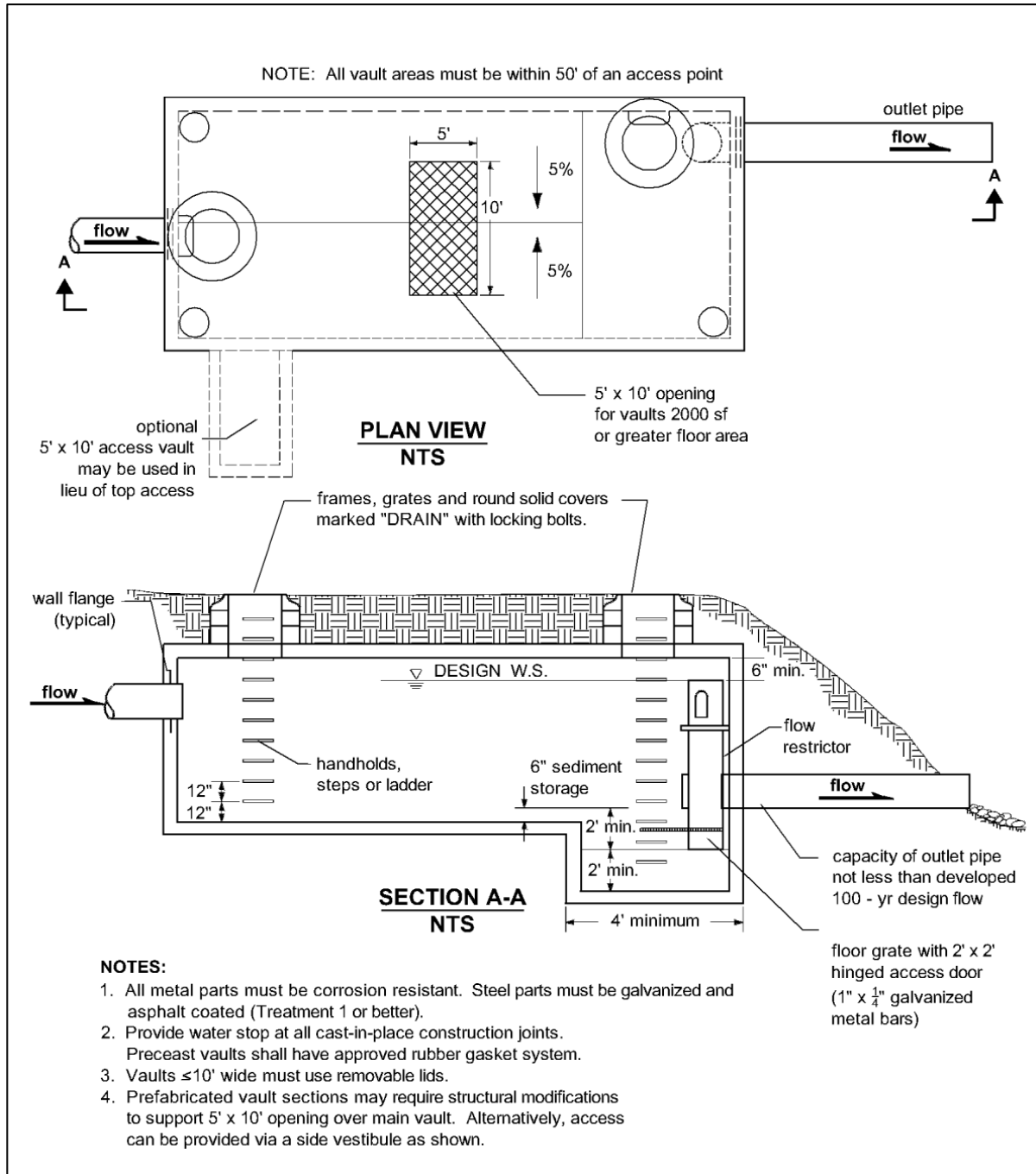
### **7.3.1.6 Methods of Analysis**

#### ***Detention Volume and Outflow***

The volume and outflow design for detention tanks must be in accordance with Minimum Requirement # 7 in Volume 1 and the hydrologic analysis and design methods in Chapter 1. Restrictor and orifice design are given in Section 7.5.

## **7.4 Detention Vaults**

*Detention vaults* are box-shaped underground storage facilities typically constructed with reinforced concrete. A standard detention vault detail is shown in Figure 3 - 22. Control structure details are shown in Section 7.5.



**Figure 3 - 22. Typical Detention Vault**

## **7.4.1 Design Criteria**

### **7.4.1.1 General**

- Detention vaults shall be designed as flow-through systems with bottoms level (longitudinally) or sloped toward the inlet to facilitate sediment removal. Distance between the inlet and outlet should be maximized (as feasible).
- The detention vault bottom shall slope at least 5 percent from each side towards the center, forming a broad “v” to facilitate sediment removal. More than one “v” may be used to minimize vault depth. The vault bottom may be flat with 0.5 – 1 foot of sediment storage if removable panels are provided over the entire vault. It is recommended that the removable panels be at grade, have stainless steel lifting eyes, and weigh no more than 5 tons per panel.
- The invert elevation of the outlet shall be elevated above the bottom of the vault to provide an average 6 inches of sediment storage over the entire bottom. The outlet shall also be elevated a minimum of 2 feet above the orifice to retain oil within the vault.
- Details of outflow control structures are given in Section 7.5.

### **7.4.1.2 Materials**

Minimum 3,000 psi structural reinforced concrete may be used for detention vaults. All construction joints must be provided with water stops. Acceptable materials for stormwater facilities include plastics, iron, aluminum, stainless steel and concrete. Zinc galvanized materials are prohibited. Galvanized metal pipes may only be used if they employ a protective asphalt coating or other Environmental Services approved coating.

### **7.4.1.3 Structural Stability**

All vaults must meet structural requirements for overburden support and H-20 traffic loading. Vaults located under roadways must meet live load requirements of the City. Cast-in-place wall sections must be designed as retaining walls. Structural designs for cast-in-place vaults must be stamped by a licensed structural engineer or civil engineer with structural expertise. Vaults must be placed on stable, well-consolidated native material with suitable bedding. Vaults must not be placed in fill slopes, unless analyzed in a geotechnical report for stability and constructability.

### **7.4.1.4 Access**

The following requirements for access shall be met along with those stipulated in Section 7.1.2.

- Access must be provided over the inlet pipe and outlet structure.
- Access openings shall be positioned a maximum of 50 feet from any location within the vault. Additional access points may be needed on large vaults.
- An access opening shall be provided directly above the lowest point of each “v” in the vault floor.
- An access opening shall be provided directly above each connection to the vault.
- For vaults with greater than 1,250 square feet of floor area, a 5' x 10' removable panel should be provided over the inlet pipe (instead of a standard frame, grate and solid cover). Alternatively, a separate access vault may be provided, as shown in Figure 3 - 22.
- For vaults under roadways, the removable panel must be located outside the travel lanes. Alternatively, multiple standard locking manhole covers may be provided.
- Ladders and hand-holds shall be provided at all access openings, and as needed to meet OSHA confined space requirements.

- All access openings, except those covered by removable panels, may have round, solid locking lids, or 3-foot square, locking diamond plate covers.
- Vaults with widths 10 feet or less must have removable lids.
- The maximum depth from finished grade to the vault invert shall be 20 feet.
- Internal structural walls of large vaults should be provided with openings sufficient for maintenance access between cells. The openings should be sized and situated to allow access to the maintenance “v” in the vault floor.
- A minimum of two access openings shall be provided into each cell.
- The minimum internal height shall be 7 feet from the highest point of the vault floor (not sump), and the minimum width shall be 4 feet. However, concrete vaults may be a minimum 3 feet in height and width if used as a tank with access manholes at each end, and if the width is no larger than the height. Also the minimum internal height requirement may not be needed for any areas covered by removable panels.
- Vaults must comply with the OSHA confined space requirements, which include clearly marking entrances to confined space areas. This may be accomplished by hanging a removable sign in the access riser(s), just under the access lid.
- Ventilation pipes (minimum 12-inch diameter or equivalent) shall be provided in all four corners of vaults to allow for artificial ventilation prior to entry of maintenance personnel into the vault. Alternatively, removable panels over the entire vault, or manhole access at 12-foot spacing, may be provided.

## **7.4.2 Methods of Analysis**

### **7.4.2.1 Detention Volume and Outflow**

The volume and outflow design for detention vaults must be in accordance with Minimum Requirement # 7 in Volume 1 and the hydrologic analysis and design methods in Chapter 1. Restrictor and orifice design are given in Section 7.5.

## **7.5 Control Structures**

*Control structures* are catch basins or manholes with a restrictor device for controlling outflow from a facility to meet the desired performance.

The restrictor device usually consists of two or more orifices and/or a weir section sized to meet performance requirements. Standard control structure details are shown in Figure 3 - 23 through Figure 3 - 25.

### **7.5.1 Design Criteria**

#### **7.5.1.1 Multiple Orifice Restrictor**

In most cases, control structures need only two orifices: one at the bottom and one near the top of the riser, although additional orifices may best utilize detention storage volume. Several orifices may be located at the same elevation if necessary to meet performance requirements.

- Minimum orifice diameter is 0.5 inches. In some instances, a 0.5-inch bottom orifice will be too large to meet target release rates, even with minimal head. In these cases, do not reduce the live storage depth to less than 3 feet in an attempt to meet the performance standards. Under such circumstances, flow-throttling devices may be a feasible option. These devices will throttle flows while maintaining a plug-resistant opening.

- Orifices may be constructed on a tee section as shown in Figure 3 - 23 or on a baffle as shown in Figure 3 - 24.
- In some cases, performance requirements may require the top orifice/elbow to be located too high on the riser to be physically constructed (e.g. a 13-inch diameter orifice positioned 0.5 feet from the top of the riser). In these cases, a notch weir in the riser pipe may be used to meet performance requirements (see Figure 3 - 25).
- Backwater effects from water surface elevations in the conveyance system shall be evaluated. High tailwater elevations may affect performance of the restrictor system and reduce live storage volumes. Backwater effects shall also be analyzed for areas that are influenced by tides.

#### **7.5.1.2 Riser and Weir Restrictor**

- Properly designed weirs may be used as flow restrictors (see Figure 3 - 25 and Figure 3 - 27 through Figure 3 - 29). However, they must be designed to provide for primary overflow of the developed 100-year peak flow discharging to the detention facility.
- The combined orifice and riser (or weir) overflow may be used to meet performance requirements. However, the design must still provide for primary overflow of the developed 100-year, 24-hour peak flowrate or 100-year return period flowrate assuming all orifices are plugged. Figure 3 - 30 can be used to calculate the head in feet above a riser of given diameter and flow.

#### **7.5.1.3 Access**

The following guidelines for access may be used.

- An access road to the control structure is needed for inspection and maintenance, and must be designed and constructed as specified in Section 7.1.2.
- Manhole and catch basin lids for control structures must be locking, and rim elevations must match proposed finish grade.
- Manholes and catch basins must meet the OSHA confined space requirements, which include clearly marking entrances to confined space areas.

#### **7.5.1.4 Materials**

Acceptable materials for stormwater facilities include plastics, iron, aluminum, stainless steel and concrete. Zinc galvanized materials are prohibited. Galvanized metal pipes may only be used if they employ an approved protective coating.

#### **7.5.1.5 Maintenance**

Per Minimum Requirement #9, an operation and maintenance plan shall be prepared for all stormwater management facilities. See Volume 1, Appendix C for specific maintenance requirements. Maintenance shall be a basic consideration in design and cost-determination of the stormwater management facility.

Any standing water removed during the maintenance operation must be disposed of in a City approved manner. See the dewatering requirements in Volume 4 of this manual. Pretreatment may be necessary. Solids must be disposed in accordance with state and local waste regulations.

Facilities shall be designed and constructed such that the facility can be safely and easily inspected by one person and safely and easily maintained. This may require construction of additional inspection ports or access manholes to allow inspection access to be opened by one person.

## 7.5.2 Methods of Analysis

This section presents the methods and equations for design of **control structure restrictor devices**. Included are details for the design of orifices, rectangular sharp-crested weirs, v-notch weirs, sutro weirs, and overflow risers.

### 7.5.2.1 Orifices

Flow-through orifice plates in the standard tee section or turn-down elbow may be approximated by the general equation:

$$Q = C A \sqrt{2gh} \quad (\text{equation 4})$$

where Q	=	flow (cfs)
C	=	coefficient of discharge (0.62 for plate orifice)
A	=	area of orifice (ft <sup>2</sup> )
h	=	hydraulic head (ft)
g	=	gravity (32.2 ft/sec <sup>2</sup> )

Figure 3 - 26 illustrates this simplified application of the orifice equation.

The diameter of the orifice is calculated from the flow. The orifice equation is often useful when expressed as the orifice diameter in inches:

$$d = \sqrt{\frac{36.88Q}{\sqrt{h}}} \quad (\text{equation 5})$$

where d	=	orifice diameter (inches)
Q	=	flow (cfs)
h	=	hydraulic head (ft)

### 7.5.2.2 Rectangular Sharp-Crested Weir

The rectangular sharp-crested weir design shown in Figure 3 - 27 may be analyzed using standard weir equations for the fully contracted condition.

$$Q = C (L - 0.2H)H^{3/2} \quad (\text{equation 6})$$

where Q	=	flow (cfs)
C	=	3.27 + 0.40 H/P (ft)
H, P	=	as shown in Figure 3 - 27
L	=	length (ft) of the portion of the riser circumference as necessary not to exceed 50 percent of the circumference
D	=	inside riser diameter (ft)

**NOTE:** This equation accounts for side contractions by subtracting 0.1H from L for each side of the notch weir.

### 7.5.2.3 V-Notch Sharp - Crested Weir

V-notch weirs as shown in Figure 3 - 28 may be analyzed using standard equations for the fully contracted condition.

### 7.5.2.4 Proportional or Sutro Weir

Sutro weirs are designed so that the discharge is proportional to the total head. This design may be useful in some cases to meet performance requirements.

The sutro weir consists of a rectangular section joined to a curved portion that provides proportionality for all heads above the line A-B (see Figure 3 - 29). The weir may be symmetrical or non-symmetrical.

For this type of weir, the curved portion is defined by the following equation (calculated in radians):

$$\frac{x}{b} = 1 - \frac{2}{\pi} \text{Tan}^{-1} \sqrt{\frac{Z}{a}} \quad (\text{equation 7})$$

Where a, b, x and Z are as shown in Figure 3 - 29.

The head-discharge relationship is:

$$Q = C_d b \sqrt{2ga} \left( h_1 - \frac{a}{3} \right) \quad (\text{equation 8})$$

where Q = flow (cfs)  
g = gravity

Values of  $C_d$  for both symmetrical and non-symmetrical sutro weirs are summarized in Table 3 - 11;  $h_1$  is shown in Figure 3 - 29.

*When  $b > 1.50$  or  $a > 0.30$ , use  $C_d=0.6$ .*

### 7.5.2.5 Riser Overflow

The nomograph in Figure 3 - 30 can be used to determine the head (in feet) above a riser of given diameter and for a given flow (usually the 100-year peak flow for developed conditions).

**NOTE:**  $Q_{100}$  is either the peak 10-minute flow computed from the 100-year, 24-hour storm and a Type 1A distribution, or the 100-year return period flowrate as estimated by WWHM.



**Table 3 - 11: Values of  $C_d$  for Sutro Weirs**

<b><math>C_d</math> Values, Symmetrical</b>					
<b>a (ft)</b>	<b>b (ft)</b>				
	<b>0.50</b>	<b>0.75</b>	<b>1.0</b>	<b>1.25</b>	<b>1.50</b>
0.02	0.608	0.613	0.617	0.6185	0.619
0.05	0.606	0.611	0.615	0.617	0.6175
0.10	0.603	0.608	0.612	0.6135	0.614
0.15	0.601	0.6055	0.610	0.6115	0.612
0.20	0.599	0.604	0.608	0.6095	0.610
0.25	0.598	0.6025	0.6065	0.608	0.6085
0.30	0.597	0.602	0.606	0.6075	0.608
<b><math>C_d</math> Values, Non-Symmetrical</b>					
<b>a (ft)</b>	<b>b (ft)</b>				
	<b>0.50</b>	<b>0.75</b>	<b>1.0</b>	<b>1.25</b>	<b>1.50</b>
0.02	0.614	0.619	0.623	0.6245	0.625
0.05	0.612	0.617	0.621	0.623	0.6235
0.10	0.609	0.614	0.618	0.6195	0.620
0.15	0.607	0.6115	0.616	0.6175	0.618
0.20	0.605	0.610	0.614	0.6155	0.616
0.25	0.604	0.6085	0.6125	0.614	0.6145
0.30	0.603	0.608	0.612	0.6135	0.614

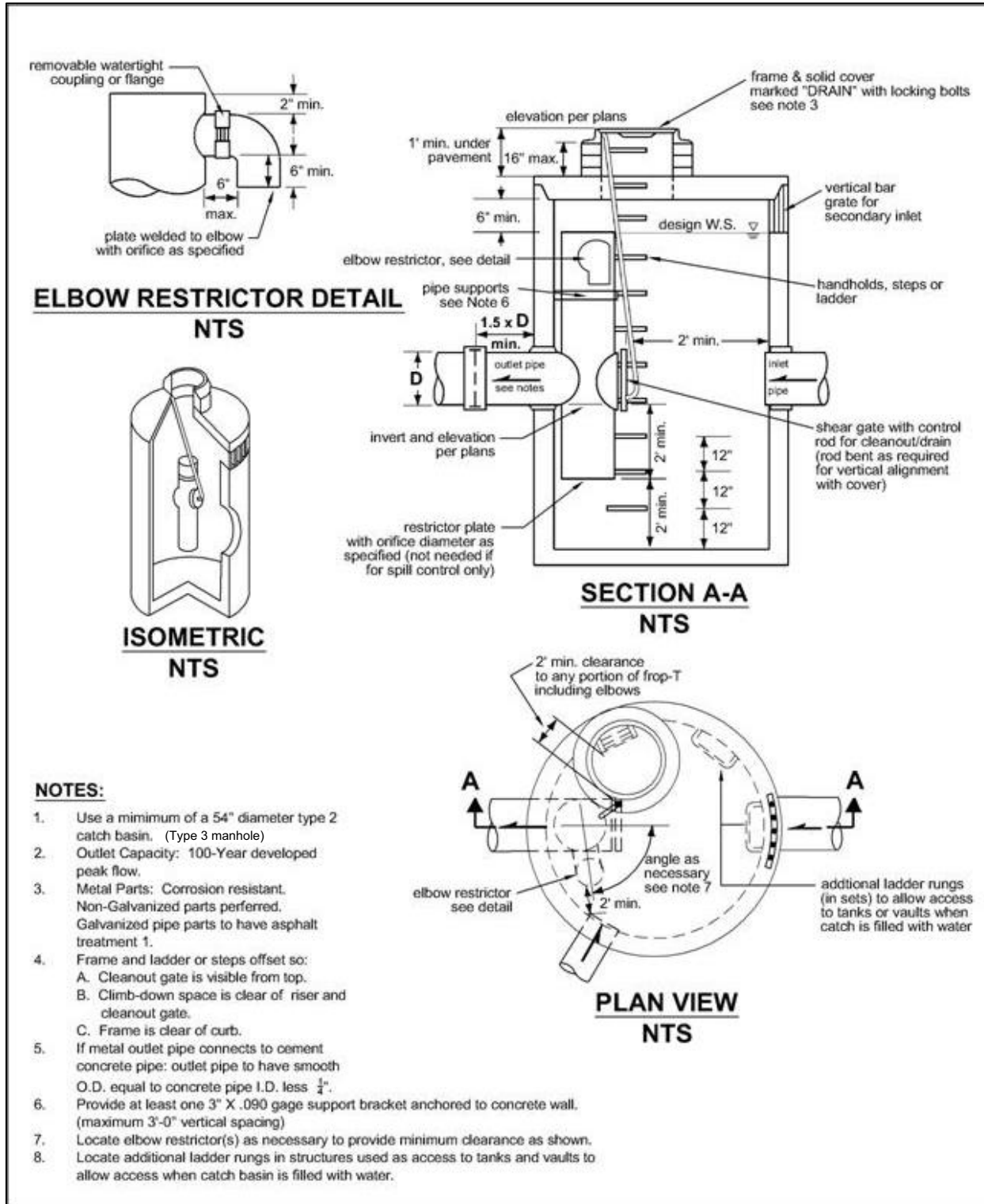


Figure 3 - 23. Flow Restrictor (TEE)

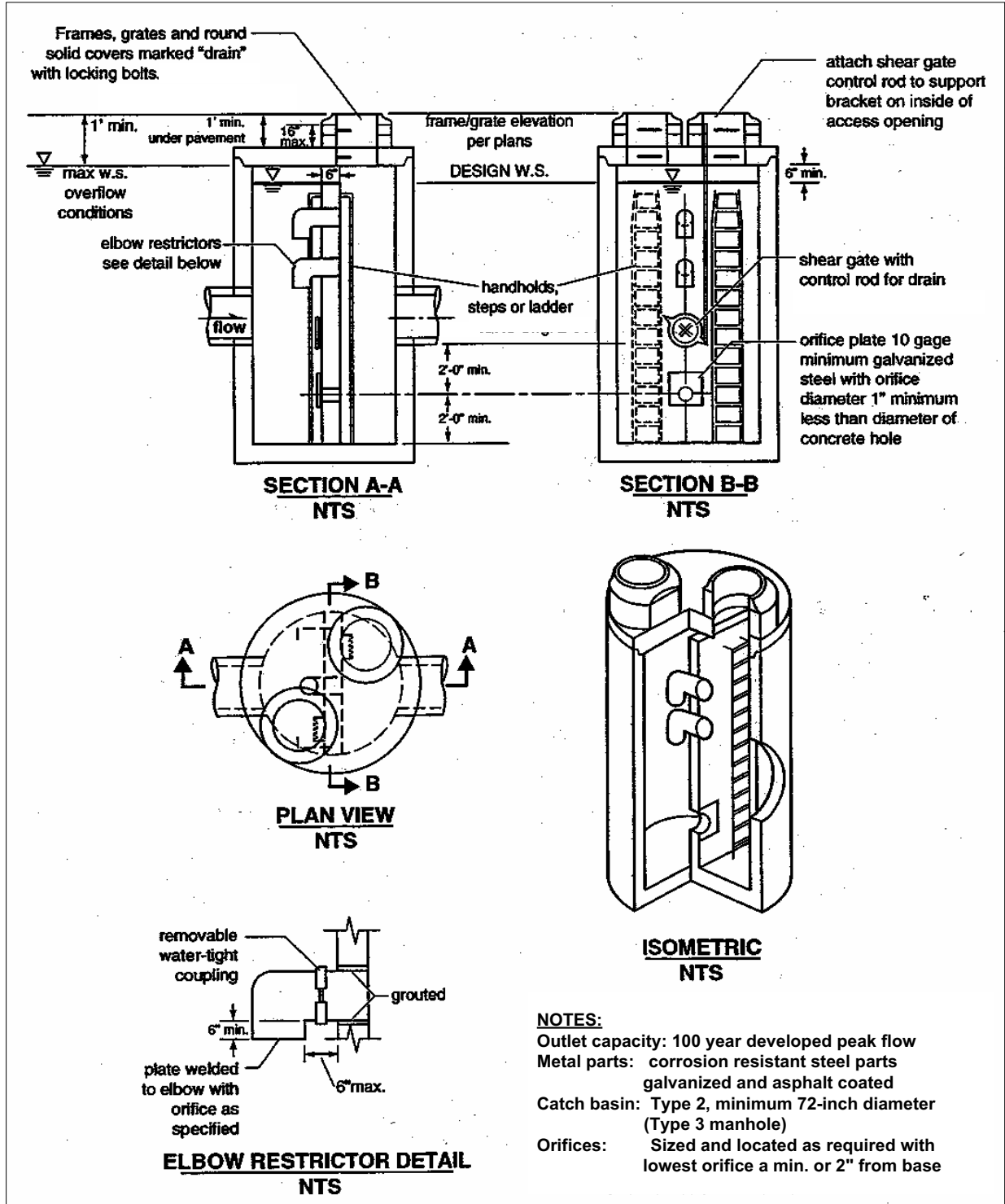


Figure 3 - 24. Flow Restrictor (Baffle)

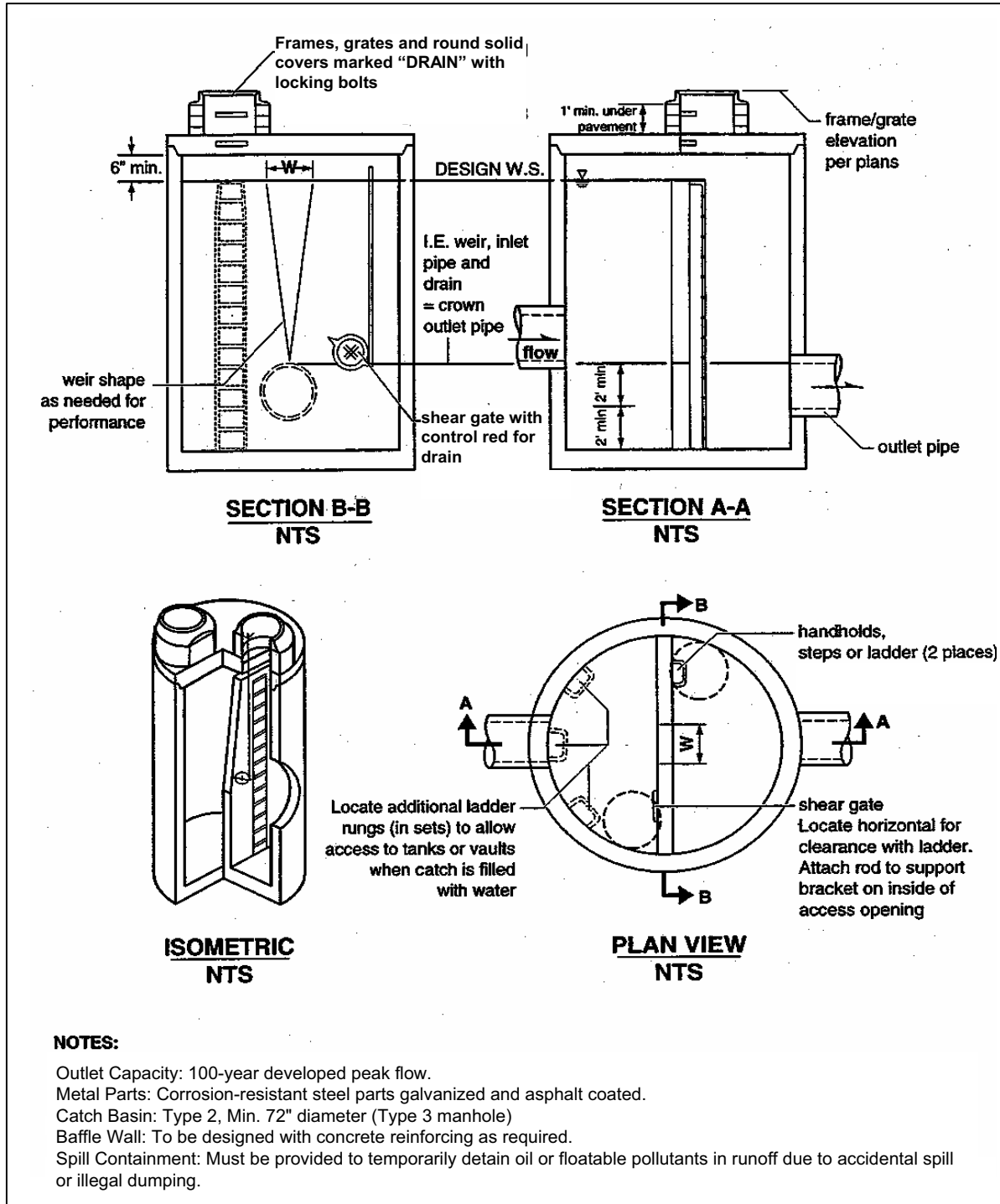


Figure 3 - 25. Flow Restrictor (Weir)

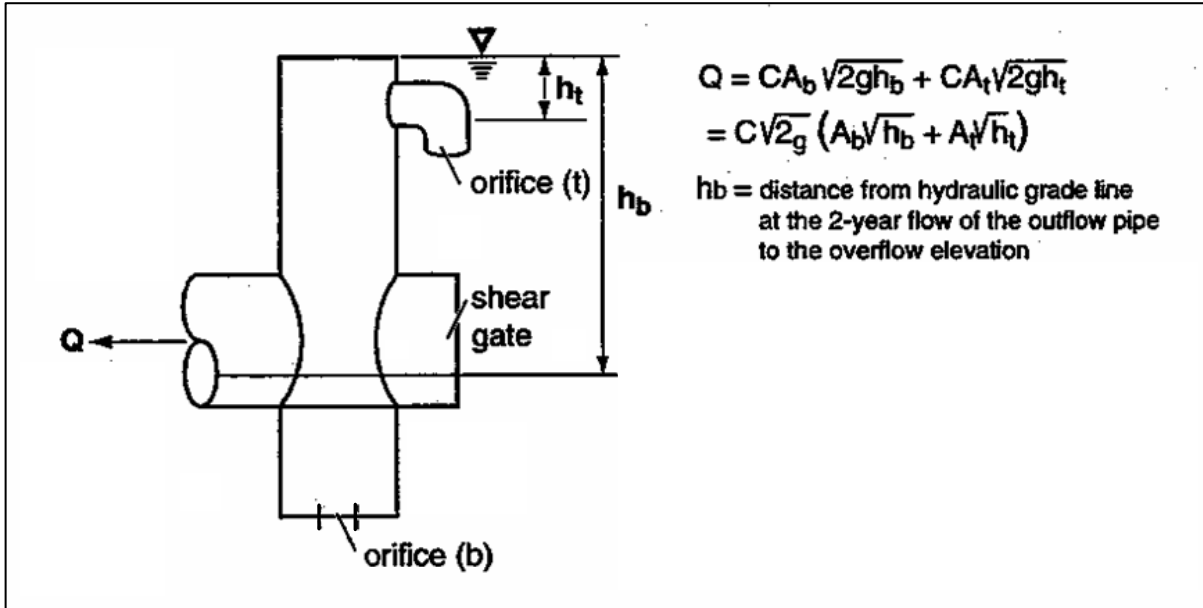


Figure 3 - 26. Simple Orifice

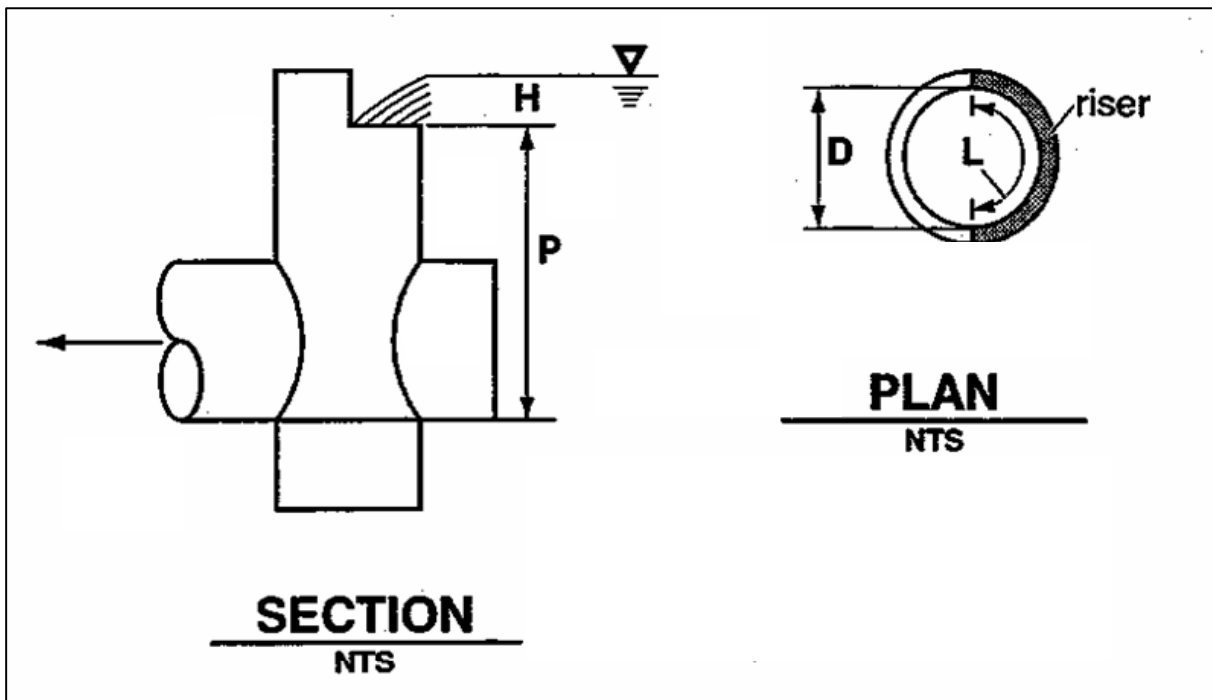


Figure 3 - 27. Rectangular, Sharp-Crested Weir

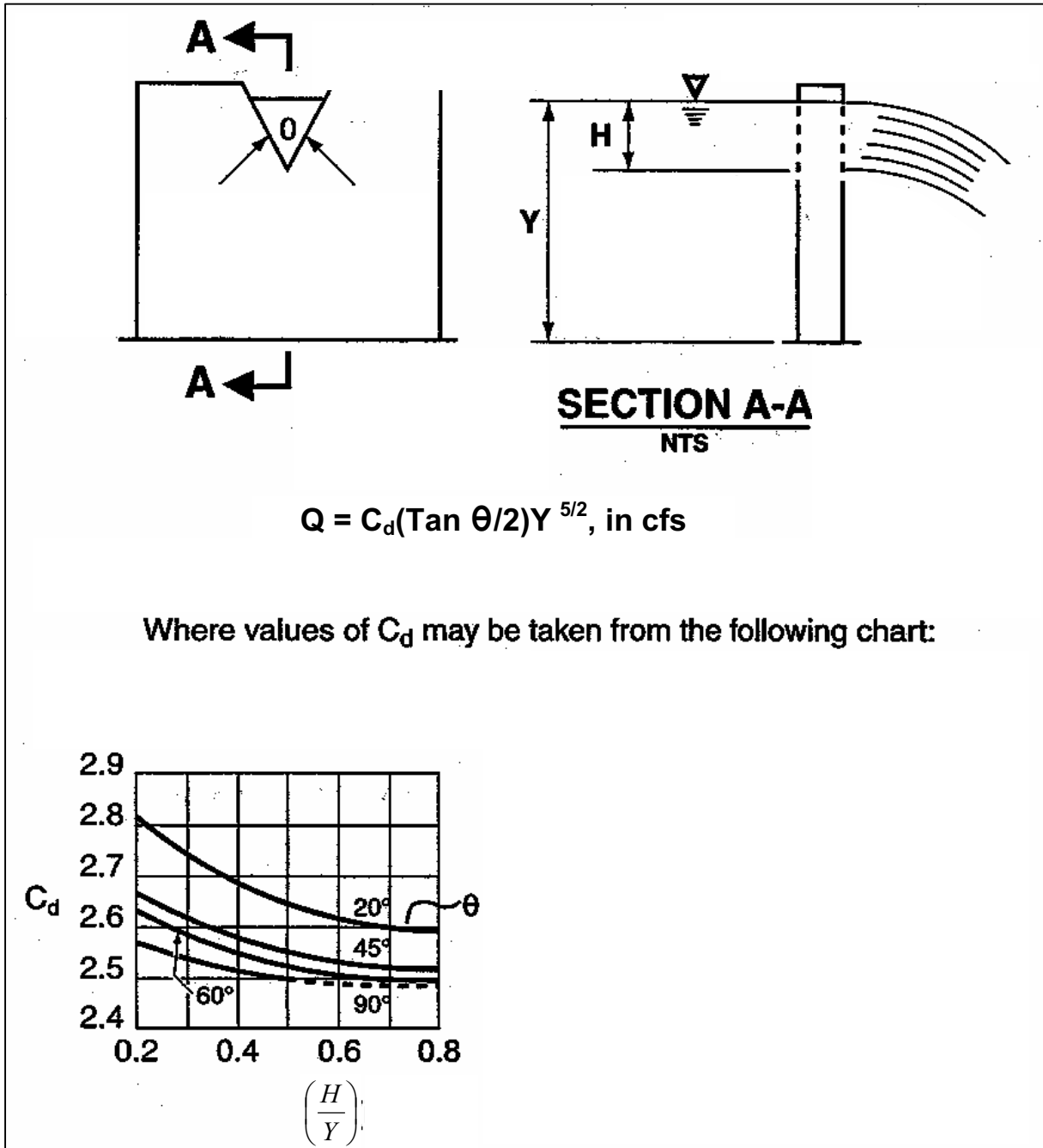


Figure 3 - 28. V-Notch, Sharp-Crested Weir

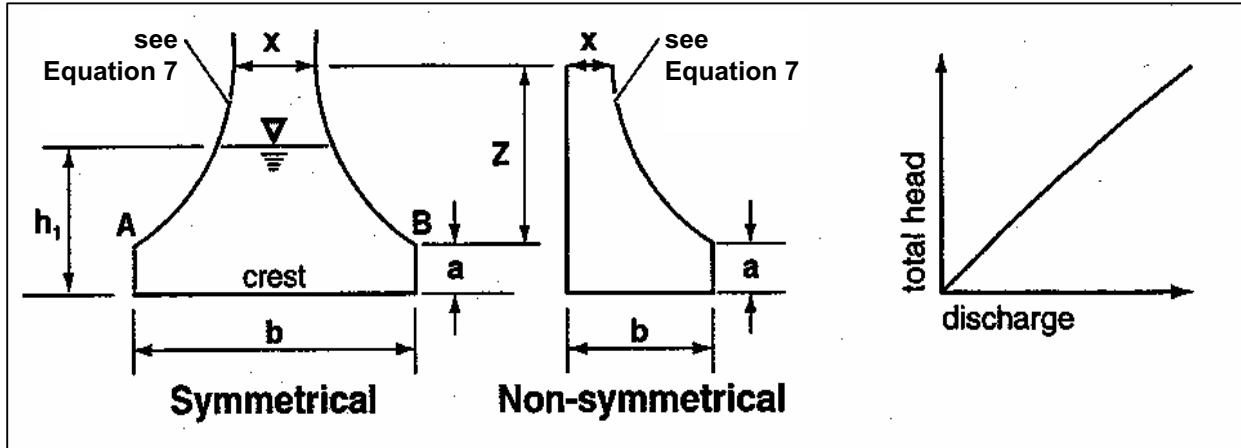


Figure 3 - 29. Sutro Weir

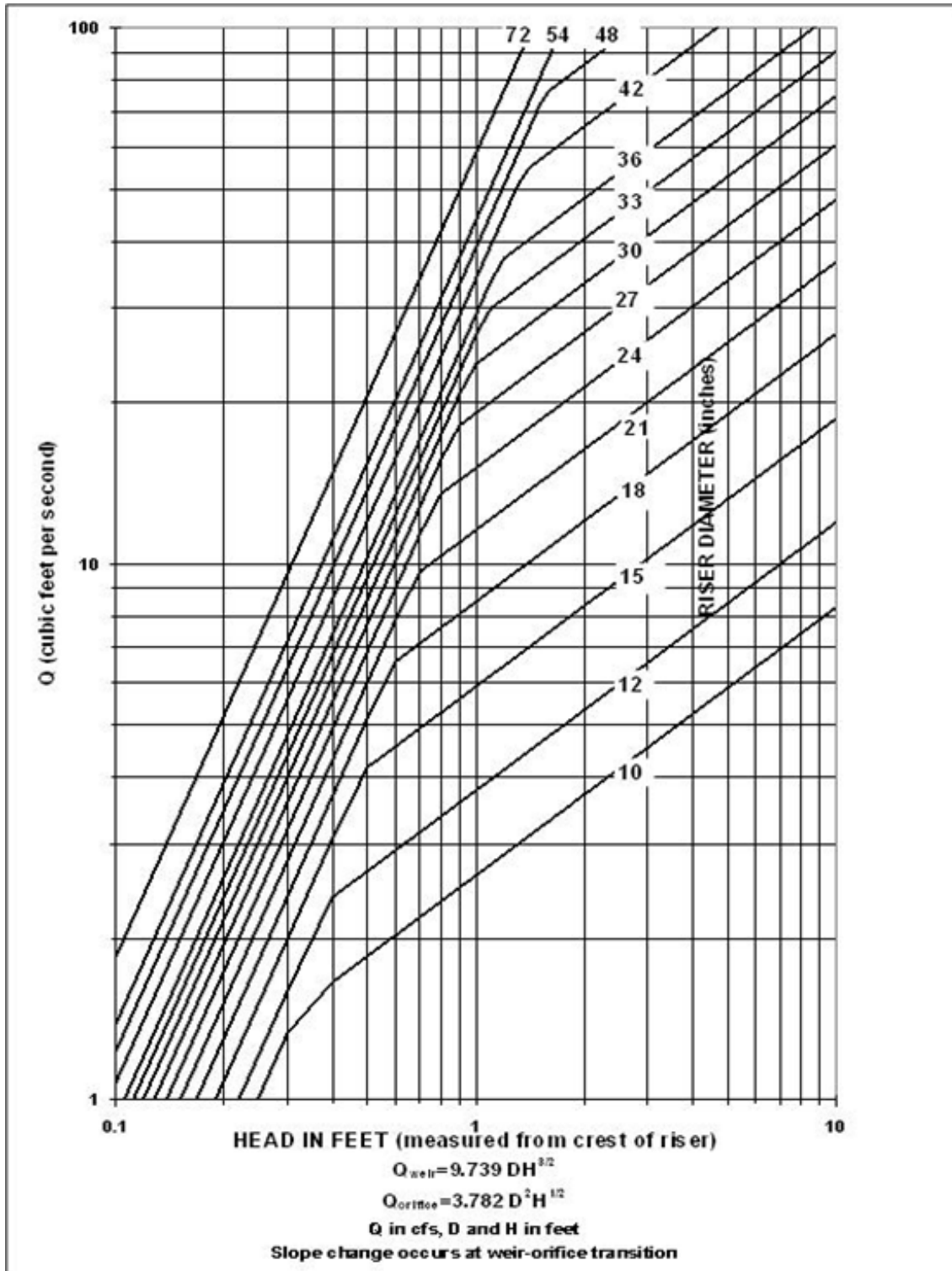


Figure 3 - 30. Riser Inflow Curves



**This Page Intentionally Left Blank**

## Chapter 8 Other Detention Options

This section presents other design options for detaining flows to meet flow control facility requirements. Written acknowledgement from the property owner shall be required for systems with above grade or roof ponding.

### 8.1 Use of Parking Lots for Additional Detention

Private parking lots may be used to provide additional detention volume for runoff events greater than the 2-year runoff event provided all of the following are met:

- The depth of water detained does not exceed 0.5 feet (6 inches) at any location in the parking lot for runoff events up to and including the 100-year event.
- The gradient of the parking lot area subject to ponding is 1 percent or greater.
- The emergency overflow path is identified and noted on the engineering plan. The overflow must not create a significant adverse impact to downhill properties or drainage system.
- Fire lanes be used for emergency equipment are free of ponding water for all runoff events up to and including the 100-year event.

### 8.2 Use of Roofs for Detention

Detention ponding on roofs of structures may be used to meet flow control requirements provided all of the following are met:

- The roof support structure is analyzed by a structural engineer to address the weight of ponded water and meets the requirements of the applicable building code.
- The roof area subject to ponding is sufficiently waterproofed to achieve a minimum service life of 30 years.
- The minimum pitch of the roof area subject to ponding is 1/4-inch per foot.
- An overflow system is included in the design to safely convey the 100-year peak flow from the roof.
- A mechanism is included in the design to allow the ponding area to be drained for maintenance purposes, or in the event the restrictor device is plugged.

**This Page Intentionally Left Blank**

## **Chapter 9 Conveyance System Design and Hydraulic Analysis**

This chapter presents acceptable methods for the analysis and design of storm and stormwater conveyance systems. Conveyance systems can be separated into the following categories:

- Pipe systems
- Culverts
- Open Channels (ditches, swales)
- Outfalls

The purpose of a conveyance system is to drain stormwater, up to a specific design flow, from properties so as to provide protection to property and the environment. This chapter contains detailed design criteria, methods of analysis and standard details for all components of a conveyance system. A complete basic understanding of hydrology and hydraulics and the principles on which the methodology of hydrologic analysis is based is essential for the proper and accurate application of methods used in designing conveyance systems.

### **9.1 Design Methods for Conveyance Systems**

Single family residences and duplexes that must comply with Minimum Requirement #1-#5 only do not have to perform a capacity analysis of their private onsite stormwater system. Analysis of the public or offsite system may be required per Minimum Requirement #7 and/or Minimum Requirement #10 if applicable.

New conveyance systems shall be designed using the Full Backwater Analysis per Section 9.3.3. The peak flowrate inputs into the analysis shall be calculated using the Santa Barbara Unit Hydrograph (SBUH) method.

Per Minimum Requirement #7 and/or Minimum Requirement #10, certain projects require that the existing conveyance systems be analyzed for capacity. See Minimum Requirement #7 and/or Minimum Requirement #10 for analysis determination. If a system is found to be under capacity, the new conveyance system shall be designed using the Full Backwater Analysis per Section 9.3.3. The peak flowrates shall be calculated using the SBUH method.

Preliminary conveyance system sizing for land use planning (short plats, plats, wetland development permits, etc.) shall use either a Uniform Flow Analysis or the Full Backwater Analysis per Section 9.3.3. The peak flowrates may be determined using either SBUH or the Rational Method per Section 9.3.4, however, SBUH is the preferred method for determining peak flowrates. The Rational Method may not be used for the final design of new conveyance systems or analyzing existing conveyance systems.

## **9.2 Methods of Analysis**

### **9.2.1 Onsite Analysis**

All proposed onsite stormwater conveyance systems, except single family residences and duplexes only required to comply with Minimum Requirement #1-#5, and all existing onsite conveyance systems required to upsize their systems based upon the analysis requirements of Minimum Requirement #7 and/or Minimum Requirement #10, shall size the conveyance system per Section 9.1.

### **9.2.2 Offsite Analysis**

#### **9.2.2.1 Qualitative Downstream Analysis**

All project applicants required to submit a Stormwater Site Plan shall perform and submit a qualitative downstream analysis of each upstream system entering a site (run-on) and each downstream system leaving a site (run-off).

The qualitative downstream analysis shall extend downstream for the entire flowpath, from the project site to the receiving water, or up to one-quarter mile, whichever is less. The qualitative analysis may be stopped shorter than the required  $\frac{1}{4}$  mile downstream if the analysis reaches a City identified trunk main. Trunk mains are defined as public stormwater drainage pipes equal to or greater than 36 inches and installed at a minimum slope of 0.5%. If the analysis includes a City-owned pump station, the analysis may stop upstream of the pump station.

The upstream qualitative analysis shall identify and describe points where water enters the site and the tributary area that contributes water to those run-on locations.

A basin map delineating the onsite and offsite basins upstream and downstream of the site shall be provided. The basin map shall be to a defined scale. Maps printed from the City's govMe website may be used as a base for the basin map, and to obtain contours and existing stormwater facility information. Field verification of govMe information may be required as directed by Environmental Services.

Depending upon the presence of existing or predicted flooding, erosion, or water quality problems, and on the proposed design of the onsite drainage facilities, the City may require additional qualitative analysis further downstream, mitigation measures adequate to address the problems, or a quantitative analysis. See Volume 1, Chapter 4 for additional details.

#### **9.2.2.2 Quantitative Downstream Analysis**

A quantitative downstream analysis is required for projects that meet the flow control thresholds as described in Minimum Requirement #7 Vol 1, Sec 3.4.7.3, except those required to provide detention per the Standard Requirement. The City may also require a quantitative downstream analysis for any project where additional downstream information is determined to be necessary. The quantitative analysis shall extend downstream for the entire flowpath, from the project site to the receiving water, or up to one-quarter mile, whichever is less. The quantitative analysis may be stopped shorter than the required  $\frac{1}{4}$  mile downstream if the analysis reaches a City identified trunk main. Trunk mains are defined as public stormwater drainage pipes equal to or greater than 36 inches and installed at a minimum slope of 0.5%. If the analysis includes a City-owned pump station, the analysis may stop upstream of the pump station. All existing and proposed offsite stormwater conveyance shall meet the design criteria described in the methods of analyses.

If a capacity problem or streambank erosion problem is found during the quantitative downstream analysis, the mitigation requirements of either Minimum Requirement #7 or Minimum Requirement #10 will apply based upon the project scope.

The City govMe mapping program and as-built drawings may be utilized to obtain structure information to be used in the downstream analysis. If as-built drawings are used, the engineer is responsible for verifying that all elevations are in the same datum. Environmental Services may require a field survey of the existing storm drainage system downstream from the project for a minimum of ¼ mile from the point of connection to the existing public drainage system, or may require portions of the system to be field surveyed.

Include the following as part of the quantitative downstream analysis:

- Capacity and percent full in each reach.
- Description of design flows used in analysis.
- Velocity in each reach.
- Upstream and downstream basin maps showing the flow route for both onsite and offsite stormwater .
- Include all model assumptions, outputs, and equations used in the analysis. If model parameters are used that are different than typical standards of practice, justification of the parameters is required.
- Clearly describe headwater and tailwater assumptions.
- The 25-year and 100-year hydraulic gradelines must be shown.
- Include model outputs for both undercapacity conditions and if the applicant is proposing to upsize the downstream system, outputs showing the upsized conditions.

### **9.3 Hydrologic Modeling**

Single event modeling shall be used for designing conveyance systems. Continuous simulation modeling is not accepted.

#### **9.3.1 Computer Models for Conveyance Systems**

All components of a conveyance system can be modeled using readily available computer models. There are several acceptable computer models available for these analyses. The project engineer is responsible for providing information describing how the model was used, assumptions the model makes and descriptions of all variables, columns, rows, summary tables, and graphs. The project engineer shall use the most current version of any model proposed within 1 year of the version's release. The City of Tacoma Environmental Services may determine that specific models are not acceptable for use in design. Please check with Environmental Services to confirm the applicability of a particular model prior to starting the analysis.

#### **9.3.2 Single Segment Capacity Analysis**

For projects required to complete the Single Segment Capacity Analysis per Minimum Requirement #7 or Minimum Requirement #10, the following criteria applies:

- The discharge rate from the increase in impervious surface coverage from a 25-year, 24-hour storm event shall be less than 5% of the discharge capacity in the most constrained

pipe segment or channel of the existing downstream system within ¼ mile from the site's discharge location at 90% full. This analysis is not required for trunk mains.

The following design criteria shall be used in the analysis:

- a. The most constrained pipe segment or channel shall be considered the pipe or channel segment with the least capacity (typically the smallest diameter pipe segment or the pipe segment with the least slope) within ¼ mile from the site's discharge location.
- b. The most constrained pipe or channel segment capacity shall be calculated assuming 90% full conditions.
- c. Flowrates shall be calculated using the Santa Barbara Hydrograph (SBUH) Method.

If it is determined that the discharge rates from the increased impervious surfaces will be equal to or greater than 5% of the capacity of the most constrained downstream pipe or channel segment, a Full Backwater Analysis is required.

### **9.3.3 Full Backwater Analysis**

The Full Backwater Analysis is used to compute a simple backwater profile (hydraulic grade line) for a proposed or existing conveyance system for the purposes of verifying capacity.

The Full Backwater Analysis begins at the downstream end of the conveyance system, when the analysis reaches a trunk main, or at the last downstream manhole of a ¼ mile analysis and is computed back through each upstream pipe segment and structure.

For discharges to tidally influenced areas, the tailwater elevation shall be the mean high tide which is 4.64 feet using current City of Tacoma datum.

#### **9.3.3.1 Full Backwater Analysis Design Criteria**

- Conveyance systems shall be modeled as if no onsite detention is provided upstream.
- Conveyance systems shall be analyzed for fully developed conditions. The fully developed conditions shall be derived from the following percentages of impervious area:
  - In commercial areas, the percent impervious shall be 85%.
  - In industrial areas, the percent impervious shall be 70%.
  - In residential areas, the percent impervious shall be 60%.

The fully developed conditions shall apply to both the offsite and onsite basins.

- Projects proposed in areas subject to tidal influence shall be analyzed at the mean high tide, which is +4.64 feet using current City datum.

#### **9.3.3.2 Pipe System Design Events**

All new conveyance systems shall be designed using the Full Backwater Analysis. The design events for pipe systems are as follows.

- For privately maintained systems, for the 10-year, 24-hour design storm, assuming a Type 1A rainfall distribution (3.0-inches), there shall be a minimum of 0.5 feet of freeboard between the water surface and the top of any manhole or catch basin.
- For publicly maintained systems, for the 25-year, 24-hour design storm, assuming a Type 1A rainfall distribution (3.5-inches), there shall be a minimum of 0.5 feet of freeboard between the water surface and the top of any manhole or catch basin.

- For privately and publicly maintained systems, for the 100-year, 24-hour design storm, assuming a Type 1A rainfall distribution (4.1-inches) overtopping of the pipe conveyance system may occur, however, the additional flow shall not extend beyond half the lane width of the outside lane of the traveled way and shall not exceed 4 inches in depth at its deepest point.
- For privately maintained systems, for the 100-year, 24-hour design storm assuming a Type 1A rainfall distribution (4.1-inches), off-channel storage on private property is allowed with recording of the proper easements. When this occurs, the additional flow over the ground surface is analyzed using the methods for open channels described in Section 9.3.3.4. Environmental Services will evaluate and determine the acceptability of this type of localized flooding.

The starting tailwater elevation to be used in the backwater analysis for pipe systems is the water surface elevation of the next downstream pipe at an assumed depth of 90% full.

For discharges to tidally influenced areas, the tailwater elevation shall be the mean high tide which is 4.64 feet using current City of Tacoma datum.

For the 100-year, 24-hour design storm assuming a Type 1A rainfall distribution (4.1-inches), if overtopping of the system occurs, the applicant shall show the extent of the impacts on neighboring properties and the right-of-way. The full extent of flooding shall be shown. The applicant may be required to provide mitigation for localized flooding. Environmental Services will make the determination of final mitigation requirements.

### **9.3.3.3 Culvert Design Events**

All new conveyance systems shall be designed using the backwater analysis. The design events for culverts systems are as follows.

- Culverts shall convey the 25-year, 24-hour peak flow rate, assuming a Type 1A rainfall distribution (3.5-inches), without submerging the culvert inlet.
- For culverts 18-inch diameter or less, the maximum allowable headwater elevation for the 100-year, 24-hour design storm, assuming a Type 1A rainfall distribution (4.1-inches), (measured from the inlet invert) shall not exceed 2 times the pipe diameter or arch-culvert-rise.
- For culverts larger than 18-inch diameter, the maximum allowable headwater elevation for the 100-year, 24-hour design storm, assuming a Type 1A rainfall distribution (4.1-inches), (measured from the inlet invert) shall not exceed 1.5 times the pipe diameter or arch-culvert-rise.
- The maximum headwater elevation at the 100-year, 24-hour design flow, assuming a Type 1A rainfall distribution (4.1-inches), shall be below any road or parking lot subgrade except as allowed per Chapter 8.

The starting tailwater elevation to be used in the backwater analysis for culverts systems is the water surface elevation of the next downstream culvert at an assumed depth of 100% full.

For discharges to tidally influenced areas, the tailwater elevation shall be the mean high tide which is 4.64 feet using current City of Tacoma datum.

### **9.3.3.4 Open Channel Design Events**

All new conveyance systems shall be designed using the backwater analysis. The design event for open channels is as follows:

- Constructed and natural channels shall contain the 100-year, 24-hour storm event, assuming a Type 1A rainfall distribution (4.1-inches).



- A minimum of 6 inches of freeboard is required for all open channels.

The Direct Step Backwater Method can be used to compute backwater profiles on prismatic channel reaches (i.e. reaches having uniform cross section and slope) where a backwater condition or restriction to normal flow is known to exist. The method can be applied to a series of prismatic channel reaches in succession beginning at the downstream end of the channel and computing the profile upstream.

Calculating the coordinates of the water surface profile using the method is an iterative process achieved by choosing a range of flow depths, beginning at the downstream end, and proceeding incrementally up to the point of interest or to the point of normal flow depth. This is best accomplished by the use of a table or computer programs. Provide documentation of the equations and assumptions used in the analysis.

The Standard Step Backwater Method is a variation of the Direct Step Backwater Method and can be used to compute backwater profiles on both prismatic and non-prismatic channels. In this method, stations are established along the channel where cross section data is known or has been determined through field survey. The computation is carried out in steps from station to station rather than throughout a given channel reach as is done in the Direct Step method. As a result, the analysis involves significantly more trial-and-error calculation in order to determine the flow depth at each station.

### 9.3.4 Rational Method

The rational method is only allowed to be used to determine peak flows for input in the Uniform Flow Analysis which can only be used for preliminary design, see Volume 3, Section 9.1

The Rational Method is a simple, conservative method for analyzing and sizing conveyance elements serving small drainage sub-basins, subject to the following specific limitations:

- Only for use in predicting peak flow rates for preliminary sizing of conveyance elements **(not for use in sizing flow control or treatment facilities)**
- Drainage sub-basin area,  $A$ , cannot exceed 10 acres for a single peak flow calculation
- The time of concentration,  $T_c$ , must be computed using the method described below and cannot exceed 100 minutes. A minimum  $T_c$  of 6.3 minutes shall be used.
- Unlike other methods of computing times of concentration, the 6.3 minutes is not an initial collection time to be added to the total computed time of concentration.

#### 9.3.4.1 Rational Method Equation

The following is the traditional Rational Method equation:

$$Q_R = C I_R A \quad \text{equation 1}$$

Where :

$Q_R$  = peak flow (cfs) for a storm of return frequency  $R$

$C$  = estimated runoff coefficient (ratio of rainfall that becomes runoff)

$I_R$  = peak rainfall intensity (inches/hour) for a storm of return frequency  $R$

$A$  = drainage sub-basin area (acres)

When the composite runoff coefficient,  $C_c$  (see equation 2) of a drainage basin exceeds 0.60, the  $T_c$  and peak flow rate from the impervious area should be computed separately. The computed

peak rate of flow for the impervious surface alone may exceed that for the entire drainage basin using the value at  $T_c$  for the total drainage basin. The higher of the two peak flow rates shall then be used to size the conveyance element.

**“C” Values**

The allowable runoff coefficients to be used in this method are shown in Table 3 - 12 by type of land cover. These values were selected following a review of the values previously accepted by Tacoma for use in the Rational Method and as described in several engineering handbooks. The value for single family residential areas were computed as composite values (as illustrated in the following equation) based on the estimated percentage of coverage by roads, roofs, yards, and unimproved areas for each density. For drainage basins containing several land cover types, the following formula may be used to compute a composite runoff coefficient,  $C_c$ :

$$C_c = (C_1A_1 + C_2A_2 + \dots + C_nA_n) / A_t \quad \text{equation 2}$$

Where:

$A_t$  = total area (acres)

$A_{1,2,\dots,n}$  = areas of land cover types (acres)

$C_{1,2,\dots,n}$  = runoff coefficients for each area land cover type

**Table 3 - 12: Runoff Coefficients - “C” Values for the Rational Method**

GENERAL LAND COVERS			
Land Cover	C	Land Cover	C
Dense forest	0.10	Gravel areas	0.80
Light forest	0.15	Pavement and roofs	0.90
Pasture	0.20	Open water (pond, lakes, wetlands)	1.00
Lawns	0.25		
SINGLE FAMILY RESIDENTIAL AREAS <i>[Density is in dwelling units per gross acreage (DU/GA)]</i>			
Land Cover Density	C	Land Cover Density	C
0.20 DU/GA (1 unit per 5 ac.)	0.17	3.00 DU/GA	0.42
0.40 DU/GA (1 unit per 2.5 ac.)	0.20	3.50 DU/GA	0.45
0.80 DU/GA (1 unit per 1.25 ac.)	0.27	4.00 DU/GA	0.48
1.00 DU/GA	0.30	4.50 DU/GA	0.51
1.50 DU/GA	0.33	5.00 DU/GA	0.54
2.00 DU/GA	0.36	5.50 DU/GA	0.57
2.50 DU/GA	0.39	6.00 DU/GA	0.60

**“ $I_R$ ” Peak Rainfall Intensity**

The peak rainfall intensity,  $I_R$ , for the specified design storm of return frequency  $R$  is determined using a unit peak rainfall intensity factor,  $i_R$ , in the following equation:

$$I_R = (P_R)(i_R) \quad \text{equation 3}$$

Where:

$P_R$  = the total precipitation at the project site for the 24-hour duration storm event for the given return frequency. Refer to Table 3 - 13 for  $P_R$  values. Total precipitation can also be found in Chapter 1 of Volume 3.

$i_R$  = the unit peak rainfall intensity factor

The unit peak rainfall intensity factor,  $i_R$ , is determined by the following equation:

$$i_R = (a_R)(T_c)^{-b_R} \quad \text{equation 4}$$

Where:

$T_c$  = time of concentration (minutes), calculated using the method described below and subject to equation limitations ( $6.3 < T_c < 100$ )

$a_R, b_R$  = coefficients from Table 3 - 13 used to adjust the equation for the design storm return frequency  $R$

Table 3 - 14 includes a table of rainfall intensity as a function of time of concentration, calculated using the coefficients from Table 3 - 13.

**Table 3 - 13: Coefficients for the Rational Method**

Design Storm Frequency	$P_R$ (inches)	$a_R$	$b_R$
2 years	2.0	1.58	0.58
5 years	2.5	2.33	0.63
10 years	3.0	2.44	0.64
25 years	3.5	2.66	0.65
50 years	3.5	2.75	0.65
100 years	4.1	2.61	0.63

**Table 3 - 14: Rainfall Intensities ( $I_R$ ) (inches per hour) for the City of Tacoma**

Time of Concentration (min)	Design Storm Recurrence Interval (Probability)					
	2-year (50%)	5-year (20%)	10-year (10%)	25-year (4%)	50-year (2%)	100-year (1%)
6.3	1.09	1.83	2.25	2.81	2.91	3.36
7	1.02	1.71	2.11	2.63	2.72	3.14
8	0.95	1.57	1.93	2.41	2.49	2.89
9	0.88	1.46	1.79	2.23	2.31	2.68
10	0.83	1.37	1.68	2.08	2.15	2.51
11	0.79	1.29	1.58	1.96	2.03	2.36
12	0.75	1.22	1.49	1.85	1.91	2.24
13	0.71	1.16	1.42	1.76	1.82	2.13
14	0.68	1.10	1.35	1.67	1.73	2.03
15	0.66	1.06	1.29	1.60	1.66	1.94
16	0.63	1.02	1.24	1.54	1.59	1.87
17	0.61	0.98	1.19	1.48	1.53	1.80
18	0.59	0.94	1.15	1.42	1.47	1.73
19	0.57	0.91	1.11	1.37	1.42	1.67
20	0.56	0.88	1.08	1.33	1.37	1.62
25	0.49	0.77	0.93	1.15	1.19	1.41
30	0.44	0.68	0.83	1.02	1.06	1.26
35	0.40	0.62	0.75	0.92	0.95	1.14
40	0.37	0.57	0.69	0.85	0.88	1.05
45	0.35	0.53	0.64	0.78	0.81	0.97
50	0.33	0.50	0.60	0.73	0.76	0.91
55	0.31	0.47	0.56	0.69	0.71	0.86
60	0.29	0.44	0.53	0.65	0.67	0.81
70	0.27	0.40	0.48	0.59	0.61	0.74
80	0.25	0.37	0.44	0.54	0.56	0.68
90	0.23	0.34	0.41	0.50	0.52	0.63
100	0.22	0.32	0.38	0.47	0.48	0.59

**“ $T_c$ ” Time of Concentration**

The time of concentration is defined as the time it takes runoff to travel overland (from the onset of precipitation) from the most hydraulically distant location in the drainage basin to the point of discharge.

Due to the mathematical limits of the equation coefficients, values of  $T_c$  less than 6.3 minutes or greater than 100 minutes cannot be used. Therefore, real values of  $T_c$  less than 6.3 minutes must be assumed to be equal to 6.3 minutes, and values greater than 100 minutes must be assumed to be equal to 100 minutes.

$T_c$  is computed by summation of the travel times  $T_t$  of overland flow across separate flowpath segments. The equation for time of concentration is:

$$T_c = T_1 + T_2 + \dots + T_n \quad \text{equation 5}$$

Where

$T_{1,2,\dots,n}$  = travel time for consecutive flowpath segments with different categories or flowpath slope

Travel time for each segment,  $t$ , is computed using the following equation:

$$T_t = L/60V \quad \text{equation 6}$$

Where

$T_t$  = travel time (minutes)

$T_t$  through an open water body (such as a pond) shall be assumed to be zero with this method.

$T_t$  = Travel time for each segment (ft)

$L$  = the distance of flow across a given segment (feet)

$V$  = average velocity (ft/s) across the land cover

$$V = (K_R)(\sqrt{S_0})$$

Where

$k_R$  = time of concentration velocity factor; see Table 3 - 15.

$s_0$  = slope of flowpath (feet/feet)

**Table 3 - 15: "n" and "k" Values Used in Time Calculations for Hydrographs**

<b>"n<sub>s</sub>" Sheet Flow Equation Manning's Values (for the initial 300 ft. of travel)</b>	
<b>Manning values for sheet flow only, from Overton and Meadows 1976<sup>a</sup></b>	<b>n<sub>s</sub></b>
Smooth surfaces (concrete, asphalt, gravel, or bare hand packed soil)	0.011
Fallow fields or loose soil surface (no residue)	0.05
Cultivated soil with residue cover ≤20%	0.06
Cultivated soil with residue cover >20%	0.17
Short prairie grass and lawns	0.15
Dense grasses	0.24
Bermuda grass	0.41
Range (natural)	0.13
Woods or forest with light underbrush	0.40
Woods or forest with dense underbrush	0.80
<b>"k" Values Used in Travel Time/Time of Concentration Calculations<sup>b</sup></b>	
<b>Sheet Flow</b>	<b>k<sub>R</sub></b>
Forest with heavy ground litter and meadow	2.5
Fallow or minimum tillage cultivation	4.7
Short grass pasture and lawns	7.0
Nearly bare ground	10.1
Grasses waterway	15.0
Paved area (sheet flow) and shallow gutter flow	20.0
<b>Shallow Concentrated Flow (After the initial 300 ft. of sheet flow, R = 0.1)</b>	<b>k<sub>s</sub></b>
1. Forest with heavy ground litter and meadows (n = 0.10)	3
2. Brushy ground with some trees (n= 0.060)	5
3. Fallow or minimum tillage cultivation (n = 0.040)	8
4. High grass (n = 0.035)	9
5. Short grass, pasture and lawns (n = 0.030)	11
6. Nearly bare ground (n = 0.025)	13
7. Paved and gravel areas (n = 0.012)	27
<b>Channel Flow (intermittent) (At the beginning of visible channels R = 0.2)</b>	<b>k<sub>c</sub></b>
1. Forested swale with heavy ground litter (n = 0.10)	5
2. Forested drainage course/ravine with defined channel bed (n = 0.050)	10
3. Rock-lined waterway (n = 0.035)	15
4. Grassed waterway (n = 0.030)	17
5. Earth-lined waterway (n = 0.025)	20
6. CMP pipe, uniform flow (n = 0.024)	21
7. Concrete pipe, uniform flow (0.012)	42
8. Other waterways and pipe	0.508/n
<b>Channel Flow (Continuous stream, R = 0.4)</b>	<b>k<sub>c</sub></b>
9. Meandering stream with some pools (n = 0.040)	20
10. Rock-lined stream (n = 0.035)	23
11. Grass-lined stream (n = 0.030)	27
12. Other streams, man-made channels and pipe	0.807/n

a. See TR-55, 1986

b. 210-VI-TR55-Second Edition, June 1986

### 9.3.5 Uniform Flow Analysis Design Events

Uniform flow analysis assumes:

- Flow is uniform in each pipe
- Friction head loss in the pipe barrel alone controls capacity. Other head losses and any backwater effects are not addressed.

The applicant can use published nomographs or Manning's equation to determine pipe size. Document all assumptions and include any tables or charts used in the analysis.

The following design assumptions shall be made:

- Conveyance systems shall be modeled as if no onsite detention is provided upstream.
- Conveyance systems shall be analyzed for fully developed conditions. The fully developed conditions shall be derived from the following percentages of impervious area:
  - In commercial areas, the percent impervious shall be 85%.
  - In industrial areas, the percent impervious shall be 70%.
  - In residential areas, the percent impervious shall be 60%.

The fully developed conditions shall apply to both the offsite and onsite basins.

#### **Pipe Systems**

The design events for pipe systems using the uniform flow analysis shall be:

- All public pipe systems shall be designed to convey the 25-year, 24-hour peak flow rates assuming a Type 1A rainfall distribution (3.5-inches) at 90% full.
- All private pipe systems less than 24 inches in diameter shall be designed to convey the 10-year, 24-hour peak flow rates assuming a Type 1A rainfall distribution (3.0-inches) at 90% full except as allowed per Chapter 8.
- All private pipe systems greater than or equal to 24 inches in diameter shall be designed to convey the 25-year, 24-hour peak flow rates assuming a Type 1A rainfall distribution (3.5-inches) at 90% full except as allowed per Chapter 8.
- For projects in areas subject to tidal influence, the 100-year, 24-hour storm event assuming a Type 1A rainfall distribution (4.1-inches) shall be analyzed and if flooding occurs, the flooding must be mapped. Flooding on private property may be allowed with recording of proper easements. Environmental Services will evaluate and determine the acceptability of this type of localized flooding.

#### **Culverts**

The design events for culverts using the uniform flow analysis shall be:

- Culverts shall convey the 25-year, 24-hour peak flow rate assuming a Type 1A rainfall distribution (3.5-inches) without submerging the culvert inlet.
- For culverts 18-inch diameter or less, the maximum allowable headwater elevation for the 100-year, 24-hour design storm (measured from the inlet invert) assuming a Type 1A rainfall distribution (4.1-inches) shall not exceed 2 times the pipe diameter or arch-culvert-rise.
- For culverts larger than 18-inch diameter, the maximum allowable headwater elevation for the 100-year, 24-hour design storm (measured from the inlet invert) assuming a Type

1A rainfall distribution (4.1-inches) shall not exceed 1.5 times the pipe diameter or arch-culvert-rise.

- The maximum headwater elevation at the 100-year, 24-hour design storm assuming a Type 1A rainfall distribution (4.1-inches) shall be below any road or parking lot subgrade except as allowed per Chapter 8.

### Open Channels

The design event for open channels using the uniform flow analysis shall be:

- Constructed and natural channels shall contain the 100-year, 24-hour storm event.
- A minimum of 6 inches of freeboard is required for all open channels at the 100-year, 24-hour storm event.

## 9.4 Inlet Grate Capacity

This section has been divided into three areas: inlets on a continuous grade, side flow interception and sag analysis. Properties of typical grate are summarized in Table 3 - 16 and further discussed below.

**Table 3 - 16: Properties of Grate Inlets**

WSDOT Standard Plan	Description	Continuous Grade <sup>a</sup>		Sump Condition <sup>b</sup> Perimeter Flows as Weir	
		Grate Width	Grate Length	Width	Length
B-30.50 <sup>c</sup>	Rectangular herringbone grate	1.67 ft (0.50 m)	2.0 ft (0.61 m)	0.69 ft (0.21 m)	0.78 ft (0.24 m)
B-30.30 or 30.40 <sup>d</sup>	Vaned grate for catch basin and inlet	1.67 ft (0.50 m)	2.0 ft (0.61 m)	1.31 ft (0.40 m)	1.25 ft (0.38 m)
B-25.20 <sup>b</sup>	Combination inlet	1.67 ft (0.50 m)	2.0 ft (0.61 m)	1.31 ft (0.40 m)	1.25 ft (0.38 m)
B-40.20	Grate Inlet Type 1 (Grate A or B <sup>e</sup> )	2.01 ft (0.62 m)	3.89 ft (0.62 m)	1.67 ft (0.50 m)	3.52 ft (1.07 m)
		3.89 ft <sup>f</sup> (1.20 m)	2.01 ft <sup>f</sup> (1.20 m)	3.52 ft (1.07 m)	1.67 ft (0.50 m)
B-30.80	Circular Grate <sup>g</sup>	1.52 ft (0.47 m)		2.55 ft <sup>h</sup> (0.79 m)	
B-40.40	Frame and Vaned Grates for Grate Inlet Type 2	1.75 ft <sup>i</sup> (0.52 m)	3.52 ft <sup>l</sup> (1.05 m)	1.29 ft (0.40 m)	2.58 ft (0.50 m)
		3.52 ft <sup>j</sup>	1.75 ft <sup>l</sup>	2.58 ft <sup>l</sup>	1.29 ft <sup>l</sup>
		(1.05 m)	(0.52 m)	(0.80 m)	(0.26 m)

a. Inlet widths on a continuous grade shown without reduction for bar area or for debris accumulation.

b. The perimeters and areas in this portion of the table have already been reduced for bar area. These values should be cut in half when used in a sag location as described in Section 9.4.4., except for the Combination Inlet B-25-20.

c. Shown for information purposes only. See Section 9.4.1.1.

d. For sag conditions, combination inlets should use a Bi-Directional Vaned grate as shown in WSDOT Standard Plan B-30.40.

e. Type B grate shall not be used in areas of pedestrian or vehicular traffic. See Section 9.4.1.4.

f. Rotated installation. See WSDOT Standard Plans.



- g. Circular grates are only allowed on private property and as approved by Environmental Services.
- h. Only the perimeter value has been provided for use with weir equations.
- i. Normal installation. See WSDOT Standard Plans.
- j. Rotated installation. See WSDOT Standard Plans.

## 9.4.1 Inlet Types

The characteristics of the most commonly used inlets are summarized below. For inlet additional specifications including dimensions see the inlet specific WSDOT Standard Plan.

### 9.4.1.1 Herringbone Pattern (WSDOT Standard Plan B-30.50)

Herringbone grates are not approved for installation within the City Right of Way. Herringbone pattern grate information is included for analyzing existing conditions and new construction on private property.

### 9.4.1.2 Vaned Grate (WSDOT Standard Plan B-30.30 or 30.40)

Catch basin grate installation within the City ROW shall use vaned type grates. The vaned grate is bicycle safe, and as described further in this section is hydraulically superior under most conditions. Installation of the vaned grate is critical as the grate is directional. If installed backwards the interception capacity is severely limited. At low velocities the vaned grate and herringbone grate are equally efficient. At higher velocities, greater than 5 ft/s (1.5 m/s), a portion of the flow tends to skip over the herringbone whereas the vaned grate will capture a greater portion of this flow. The vaned grate also has a higher capacity for passing debris and should be used for high debris areas. Where existing catch basins are modified, grates may be required to be replaced with vaned grates. Environmental Services will make the final determination based on the condition of the existing grate.

### 9.4.1.3 Combination Inlets (WSDOT Standard Plan B-25.20)

The combination inlet is a vaned grate on a catch basin with a hooded curb cut area. Its vaned grate is very debris efficient, and if the grate does become clogged, the overflow goes into the hooded opening. These inlets are extremely useful for sag condition installations, although they can also be effective on continuous grades. The interception capacity of a combination inlet is only slightly greater than with a grate alone. Therefore the capacity is computed neglecting the curb opening and designers should follow the same analysis as for a vaned grate alone for typical design events. Combination inlets may be useful for providing additional inlet capacity during more intense peak events. See Section 9.4.4 for design guidance in a sag condition.

### 9.4.1.4 Grate Inlets Type 1 or 2 (WSDOT Standard Plans B-35.20, B-35.40, and B-40.20)

Both Type 1 or 2 grate inlets have large openings that can compensate for debris problems, however, there are limitations in their usage. A Type 1 grate inlet is a non-reinforced, cast-in-place concrete inlet, which cannot support traffic loads. Type 2 grate inlets are pre-cast and can withstand traffic loading. These inlets are installed with a Grate A or Grate B (see WSDOT Standard Plan B-40.20-00) or a frame and vaned grate (see the next paragraph and WSDOT Standard Plan B-40.40-01 for more information on frame and vaned grates). Due to structural failure of both Grates A or B, neither of these grates can be installed in heavy traffic areas where wheel loads will pass directly over. Grate B has very large openings and is useful in ditches or non-paved median locations, in areas where there is no pedestrian or bicycle traffic. Grate A can be used anywhere Grate B is used as well as at the curb line of a wide interstate shoulder. Grate A may occasionally be hit by low-speed traffic or parked on but it cannot withstand repeated interstate loading or turning vehicles.

### 9.4.1.5 Frame and Vaned Grates (WSDOT Standard Plan B-40.40)

WSDOT Standard Plan B-40.40 has been tested in H-25 loading and was determined compatible with heavy traffic installations. This frame and double vaned grate should be installed in a Unit H on top of a grate inlet Type 2. The frame and vaned grates may be used in either new construction or retrofit situations. When used in areas of highway speeds, lock down grates should be specified.

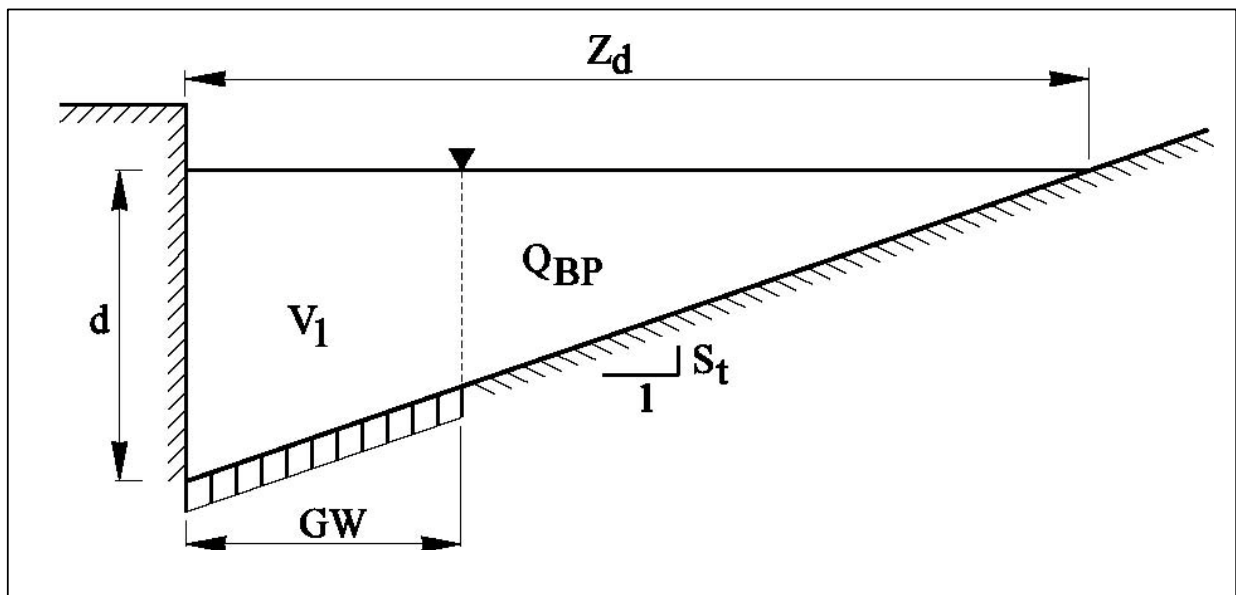
### 9.4.1.6 Circular Grates

See WSDOT Standard Plans B-20.20 and WSDOT B-20.60 for details. Install with circular frames (rings) as detailed in WSDOT Standard Plan B-30.70. Circular grates are only allowed for use on private property and as approved by Environmental Services.

## 9.4.2 Capacity of Inlets on a Continuous Grade

The interception capacity of an inlet on a continuous grade depends on the amount of water flowing over the grate, the size and configuration of the grate, the velocity of the flow in the gutter, and the longitudinal slope of the roadway.

- For longitudinal slopes between 2 to 3 percent and for velocities in the range of 3 to 5 ft/s the interception capacity of an inlet is based mainly on frontal flow. Frontal flow is water that travels through the gutter and enters through the front side (width) of the inlet.
- For longitudinal slopes less than 2 percent and velocities less than 3 ft/s side flow interception shall also be considered as described in Section 9.4.3. An inlet will intercept essentially all frontal flow passing over the width of the inlet as long as the velocity is less than 5 ft/s.
- When velocities exceed 5 ft/s water will “splash-over” the inlets reducing the portion of the flow that will be intercepted and increase the bypass flow. When this occurs, consult with Environmental Services to determine a design appropriate for the location. Additional guidance can be found in the FHWA HEC No. 22, Section 4-3 at: [www.fhwa.dot.gov/engineering/hydraulics/library\\_arc.cfm?pub\\_number=22&id=47](http://www.fhwa.dot.gov/engineering/hydraulics/library_arc.cfm?pub_number=22&id=47).



**Figure 3 - 31. Section at Inlet**

The flow that is not intercepted by the first grate inlet is considered bypass flow and should be added to the flow traveling toward the next grate located downstream. This carry-over process continues to the bottom of the grade or the end of the inlet system.

The last inlet on the system is allowed to bypass 0.28 cfs during the 25-year, 24-hour storm event as calculated using the SBUH method of a single event model. If discharges exceed 0.28 cfs, additional catch basins or structures will be required to handle the flow.

The amount of flow bypassing the inlet on a continuous grade is computed as follows:

$$Q_{BP} = Q \left[ \frac{(Z_d) - (GW)}{(Z_d)} \right]^{8/3} \quad \text{equation 7}$$

Where:

- $Q_{BP}$  = portion of flow outside the width of the grate, cfs
- $Q$  = total flow of gutter approaching the inlet, cfs
- $Z_d$  = top width of the flow prism, feet
- $GW$  = width of the grate inlet perpendicular to the direction of flow in feet, assuming that grates areas are 80% free of debris and vaned grates are 95% free of debris.

The flow that is intercepted by the inlet is calculated as follows:

$$Q_i = \Delta Q - Q_{BP} \quad \text{equation 8}$$

The velocity of flow directly over the inlet is calculated as follows:

$$V_{\text{continuous}} = \frac{Q - Q_{BP}}{(GW)[d - 0.5(GW)(S_t)]} \quad \text{equation 9}$$

Where:

- $V_{\text{continuous}}$  = velocity over the inlet in ft/s (m/s)
- $S_t$  = transverse slope or superelevation in ft/ft (m/m)
- $d$  = depth of flow at the face of the curb in ft (m)

#### 9.4.2.1 Inlet Analysis Spreadsheet

A Microsoft Excel spreadsheet has been developed by the Washington State Department of Transportation that follows the procedure to calculate roadway runoff and inlet interception for a roadway on a longitudinal slope. When velocities are less than 3 ft/s and the longitudinal slope is less than 2 percent, the spreadsheet will automatically consider side flow in the analysis. Also, when velocities exceed 5 ft/s or the bypass flow at the last inlet exceeds 0.28 cfs, the

spreadsheet will warn the designer. The spreadsheet is located at [www.wsdot.wa.gov/Design/Hydraulics/Programdownloads.htm](http://www.wsdot.wa.gov/Design/Hydraulics/Programdownloads.htm). The 25-year, 24-hour storm event as predicted from a single event model shall be used in this analysis.

### 9.4.3 Side Flow Interception

For longitudinal slopes less than 2 percent and when equation 9 yields velocities less than 3 ft/s, side flow interception begins to make an appreciable contribution to the inlet capacity analysis and should be considered.

The velocity of flow entering the side of an inlet is shown in equation 10.

$$V_{\text{side}} = \left(\frac{1.11}{n}\right)(S_L^{0.5} S_t^{0.67} Z_d^{0.67}) \quad \text{equation 10}$$

Where:

$V_{\text{side}}$  = velocity in triangular channel in ft/s

$n$  = 0.015 (Manning's value for concrete pavement)

$S_L$  = longitudinal slope in ft/ft

$S_t$  = transverse slope or superelevation in ft/ft (m/m)

$Z_d$  = top width of the flow prism, ft

The ratio of frontal flow to total gutter flow is shown in equation 11.

equation 11

$$E_o = 1 - \left(1 - \frac{GW}{Z_d}\right)^{2.67}$$

Where:

$GW$  = width of depressed grate in ft

$Z_d$  = top width of the flow prism in ft

The ratio of side flow intercepted to total side flow is shown in equation 12.

$$R_S = \frac{1}{\left(1 + \frac{0.15V_{\text{side}}^{1.8}}{S_t GL^{2.3}}\right)} \quad \text{equation 12}$$

Where:

$GL$  = grate length

The efficiency of the grate is expressed in equation 13.

$$E = R_f E_o + R_s (1 - E_o) \quad \text{equation 13}$$

Where:

$R_f$  = Ratio of front flow intercepted to total frontal flow

The amount of flow intercepted by an inlet when side flow is considered is expressed in equation 14.

$$Q_i = Q(R_f E_o + R_s (1 - E_o)) \quad \text{equation 14}$$

#### 9.4.3.1 Inlet Analysis Spreadsheet

A Microsoft Excel spreadsheet has been developed by the Washington State Department of Transportation that follows the procedure to calculate roadway runoff and inlet interception for a roadway on a longitudinal slope. When velocities are less than 3 ft/s and the longitudinal slope is less than 2 percent, the spreadsheet will automatically consider side flow in the analysis. Also, when velocities exceed 5 ft/s or the bypass flow at the last inlet exceeds 0.28 cfs, the spreadsheet will warn the designer. The spreadsheet is located at [www.wsdot.wa.gov/Design/Hydraulics/Programdownloads.htm](http://www.wsdot.wa.gov/Design/Hydraulics/Programdownloads.htm). The 25-year, 24-hour storm event as predicted from a single event model shall be used in this analysis.

#### 9.4.4 Capacity of Inlets in Sag Locations

By definition, a sag is any portion of the roadway where the profile changes from a negative grade to a positive grade. Inlets at sag locations perform differently than inlets on a continuous grade and therefore require a different design criterion. Theoretically, inlets at sag locations may operate in one of two ways: (1) at low ponding depths, the inlet will operate as a weir; and (2) high ponding depths (5" depth above the grated inlet and 1.4 times the grate opening height for combination inlets), the inlet will operate as an orifice. It is very rare that ponding on a roadway will become deep enough to force the inlet to operate as an orifice. As a result, this section will focus on inlets operating as a weir with flow spilling in from the three sides of the inlet that are exposed to the ponding.

Inlets at sag locations can easily become plugged with debris and therefore, it is good engineering practice to provide some type of relief. This relief can be accomplished by locating flanking inlets, on either side of the sag inlet, so they will operate before water exceeds the allowable spread into the travel lane at the sag. This manual recommends flanking inlets be located so the depth of water at the flanking inlet ponds to half the allowable depth at the sag ( $\frac{1}{2}d_B$ ). With that said, flanking inlets are only required when the sag is located in a depressed area and water has no outlet except through the system. However, if runoff is capable of overtopping the curb and flowing away from the roadway before exceeding the allowable limits noted in Table 3 - 17, flanking inlets are not required. With this situation there is a low potential for danger to drivers if the inlets do not function as designed. Before flanking inlets are removed in this situation, designers should consider the potential damage of water going over the curb.

Designers should use the guidelines provided in this section for locating flanking inlets. If a designer suspects flanking inlets are unnecessary, consult Environmental Services early in the design for approval.

Any section of roadway located in a sag should be designed according to the criteria described below. To aid the designer in sag analysis, a copy of the sag worksheet is located on the WSDOT Hydraulic web page at <http://www.wsdot.wa.gov/publications/fulltext/Hydraulics/Programs/SagWorksheetud.xls>. The 25-year, 24-hour storm event as predicted from a single event model shall be used in the analysis.

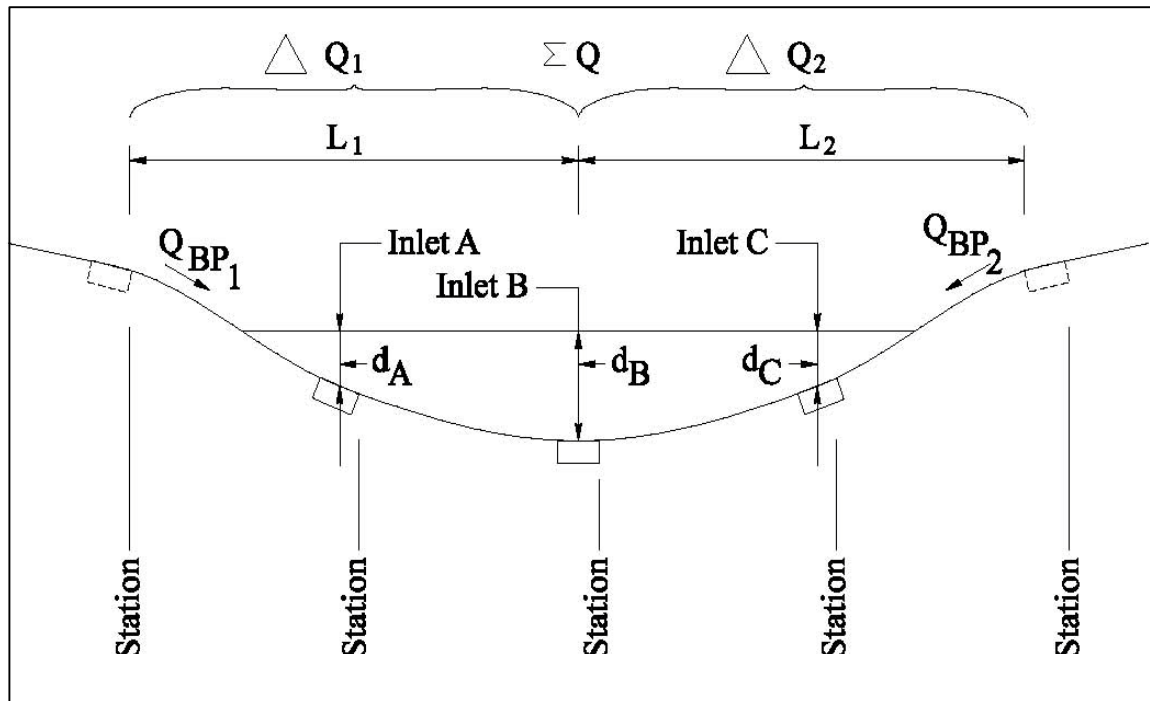


Figure 3 - 32. Sag Analysis

Once an inlet has been placed in a sag location, the total actual flow to the inlet can be determined as shown below.  $Q_{Total}$  must be less than  $Q_{allowable}$  as described in equation 15.

$$Q_{Total} = Q_{BP1} + Q_{BP2} + \Delta Q_1 + \Delta Q_2 \quad \text{equation 15}$$

Where:

$Q_{BP1\&2}$  = bypass flow from the last inlet on either side of a continuous grade calculated using equation 7.

$\Delta Q_{1\&2}$  = runoff that is generated from the last inlet on either side of the continuous grades, see WSDOT Standard Plan B-25.20-00.

The effective perimeter of the flanking and sag inlets can be determined using the length and widths for various grates given in Figure 3 - 31. This would be the sum of the three sides of the inlet where flow spills in and where ponding would occur. The grates shall be assumed to be 50 percent plugged, the vaned grates should be assumed to be 75% free, and the Combination Inlet B-25.20, which should be considered 100 percent free. This adjustment is in addition to reducing the perimeter to account for the obstruction caused by the bars in the grate. Figure 3 - 31 lists perimeters for various grates with reductions already made for bars.

$$P_n = 0.5[L + 2W] \quad \text{equation 16}$$



Where:

P = effective perimeter of the flanking and sag inlet

L = length of the inlet from Table 3 - 16.

W = width of inlet from Table 3 - 16.

The allowable capacity of an inlet operating as a weir, that is the maximum  $Q_{\text{allowable}}$ , can be found depending on the inlet layout as described below:

When there is only a single inlet at the sag (no flanking inlets) the following equation should be used:

$$Q_{\text{allowable}} = C_w \times P \times d_{\text{B allowable}}^{1.8} \quad \text{equation 17}$$

Where:

$C_w$  = weir coefficient; 3.0 for English Units, 1.66 for Metric Units

P = effective perimeter of the grate in feet

$d_{\text{B allowable}}$  = maximum depth of water at the sag inlet in feet

As noted previously it is recommended that flanking inlets be located laterally from the sag inlet at a distance equal to  $0.5d_{\text{B allowable}}$ . When this recommendation is followed,  $Q_{\text{allowable}}$  can be simplified as shown below. If the inlets are not all the same size, the following equation will need to be modified to account for different perimeters:

$$\Sigma Q = C_w \times P \times [2(0.5d_B)^{1.5} + (d_B)^{1.5}] \quad \text{equation 18}$$

Where  $d_B$  = depth of water at the sag inlet (ft)

In some applications, locating inlets so water ponds to  $0.5d_{\text{B allowable}}$  is too far (generally in cases with long flat slopes). Designers should instead ensure that the spread of stormwater does not exceed those noted in Table 3 - 17 and use equation 19.

$$Q_{\text{allowable}} = C_w P [d_A^{1.5} + d_B^{1.5} + d_C^{1.5}] \quad \text{equation 19}$$

Where:

$d_N$  = depth of water at the flanking inlets and the sag (ft)

The actual depth of water over the sag inlet can be found with equation 20 below and must be less than  $d_{B \text{ allowable}}$ . If however, the inlets are or are not located at  $0.5d_{B \text{ allowable}}$ , equation 19 will need to be modified to reflect this.

$$d_B = \left[ \frac{Q_{\text{total}}}{(C_{WA}P_A 0.3536 + C_{WB}P_B + C_{WC}P_C 0.3536)} \right]^{\frac{2}{3}} \quad \text{equation 20}$$

Where:

$Q_{\text{total}}$  = actual flow into the inlet in cfs (cms)

$C_W$  = weir coefficient, 3.0 (1.66 for metric)

$P_N$  = effective grate perimeter, in feet (m), see Figure 3 - 31

$d_B$  = actual depth of ponded water at the inlet in feet (m)

Verify the allowable depth and flow have not been exceeded. That is verify  $Q_{\text{allowable}} > Q_{\text{Total}}$  and  $d_{B \text{ allowable}} > d_B$ . If the allowable flow and depth are greater than the actual, the maximum allowable spread will not be exceeded and the design is acceptable. If the actual depth or flow is greater than the allowable, then the runoff will spread beyond the maximum limits and the design is not acceptable. In this case, the designer should add flanking inlets or replace the three original inlets with inlets that have larger openings. If additional flanking inlets are used they should be placed close to the sag inlet to increase the flow interception and reduce the flow into the sag.

### 9.5 Gutter Capacity Analysis

When stormwater is collected and carried along the roadside in a gutter, the allowable top width of the flow prism (Zd) is dependent on the Road Classification as noted in Table 3 - 17.

**Table 3 - 17: Design Frequency and Spread**

Road Classification		Design Frequency <sup>a</sup>	Design Spread (Zd)
Arterial	< 45 mph (70 km/hr)	25-year	6.25 ft <sup>b</sup>
	≥ 45 mph (70 km/hr)	25-year	
	Sag Pt.	50-year	
Collector and Local Streets	< 45 mph (70 km/hr)	25-year	6.25 ft <sup>c</sup>
	≥ 45 mph (70 km/hr)	25-year	
	Sag Pt.	50-year	

a. The 24-hour storm event as calculated using the SBUH method of a single event.

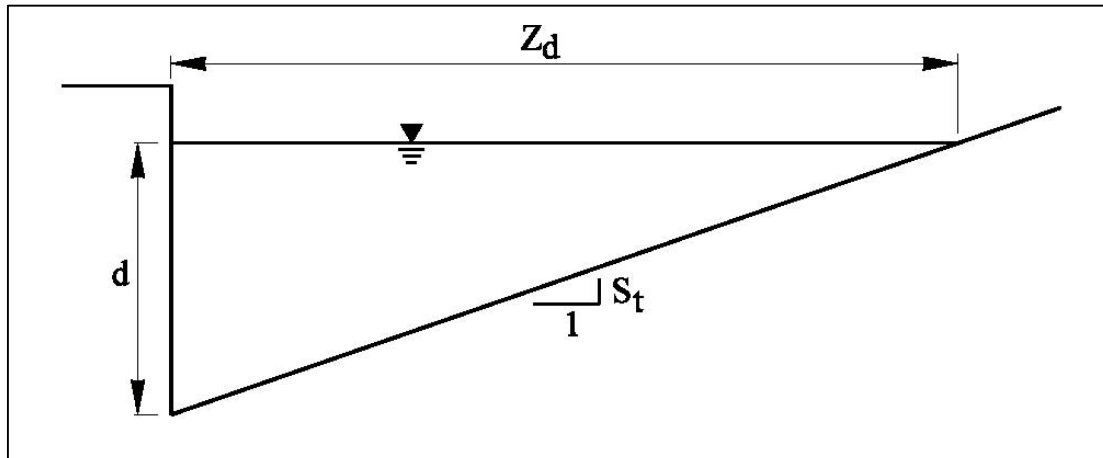
b. The travel way shall have at least 10 feet that is free of water.

c. In addition to the design spread requirement, the depth of flow shall not exceed 0.13 feet at the edge of the shoulder.

In addition to the requirements above, areas where a superelevation transition causes a crossover of gutter flow, the amount of flow calculated at the point of zero superelevation shall be limited to 0.28 cfs. The designer will find, by the time the roadway approaches the zero point, the

$Z_d$  will become very wide. The flow width criteria will be exceeded at the crossover point even when the flow is less than 0.28 cfs.

The equation for calculating the gutter flow capacity is a modified version of Manning's Equation. It is based on a roughness coefficient of 0.015, which assumes a rough, concrete or asphalt pavement gutter. (equation 21) and (equation 22) assume a uniform gutter section as shown in Figure 3 - 33. If the gutter section is different, designers should consult the *Hydraulic Engineering Circular No. 22*, Chapter 4, for further guidance found at: [www.fhwa.dot.gov/bridge/hydpub.htm](http://www.fhwa.dot.gov/bridge/hydpub.htm).



**Figure 3 - 33. Typical Gutter Section**

$$d = \left[ \frac{\Delta O S_t}{37(S_L)^{0.5}} \right]^{3/8} \quad (\text{equation 21})$$

(equation 22)

$$Z_d = \frac{d}{S_t}$$

Where:

$d$  = depth of flow at the face of curb (ft)

$\Delta O$  = gutter discharge (cfs); this is the design event per Table 3 - 17

$S_L$  = longitudinal slope of the gutter (ft/ft); assume minimum 0.4% for cement curb and gutter and 1% for asphalt unless survey of the gutter line is conducted.

$S_t$  = transverse slope or superelevation (ft/ft); assume 2% unless survey of the slope is conducted

$Z_d$  = top width of the flow prism (ft)

## **9.6 Basis of Design**

Applicants may be required to submit a basis for pipe and culvert design which includes pipe type selection, suitability for depth of bury and loading, deflection calculations for above-ground pipes, anchoring, armoring, analysis for above ground pipes or outfalls, etc. Environmental Services will make the final determination as to when the basis of design is required.

**This page intentionally left blank**

## Chapter 10 Material Specifications

### 10.1 Pipe Specifications

Pipe systems are networks of storm drain pipes, catch basins, manholes, inlets, and outfalls, designed and constructed to convey stormwater.

#### 10.1.1 Pipe Materials

All pipe material, joints, and protective treatments shall be in accordance with the latest version of the WSDOT/APWA Standard Specifications and AASHTO and ASTM treatment standards as amended and as provided in the City of Tacoma Design Manual, this manual, or City of Tacoma Master Specifications as applicable.

##### 10.1.1.1 Pipes Within Right-of-Way

All storm drainage pipe to be installed in public right-of-way, that will be publicly maintained, or privately owned but located within the right-of-way shall conform to Table 3 - 18. The maximum deflection allowed is 5%.

**Table 3 - 18: Acceptable Pipe Material in the City Right-of-Way**

Pipe Material	Minimum SDR/Class	Reference	Specification Reference	Applicability
Solid Wall Polyvinyl Chloride (PVC) 15" diameter or less	SDR 35	ASTM D 3034	WSDOT 9-05.12(1)	Standard Use
Solid Wall Polyvinyl Chloride (PVC) 18" diameter or greater	115 psi SDR 26	ASTM F 679	WSDOT 9-05.12(1)	Standard Use
Vitrified Clay	Extra Strength	ASTM C700	WSDOT 9-05.8	Standard Use
Solid Wall PVC 12" diameter or less	SDR 18	AWWA C905	WSDOT 9-30.1(5)A	Shallow or Deep Cover, Non-Standard Separation from Water Main
Solid Wall PVC 12" diameter or greater	SDR 18	AWWA C905	WSDOT 9-30.1(5)A	Shallow or Deep Cover, Non-Standard Separation from Water Main

**Table 3 - 18: Acceptable Pipe Material in the City Right-of-Way**

Pipe Material	Minimum SDR/Class	Reference	Specification Reference	Applicability
Lined Ductile Iron	Special Thickness Class: 50 Minimum Pressure Class: 350 (If joined using bolted flanged joints - Special Thickness Class 53 required)	ANSI A21.51 or AWWA C151	WSDOT 9-015.13	Shallow or Deep Cover, Non-Standard Separation from Water Main
Plain Concrete 12" diameter or less	Class 2	AASHTO M86	WSDOT 9-05.7(1)	Standard Use
Reinforced Concrete 12" diameter or greater	Per Pipe Design	AASHTO M170	WSDOT 9-05.7(2)	Standard Use; Large Diameter
Solid Wall High Density Polyethylene (HDPE) Pipe, Heat Welded, Butt Fused	SDR 17	ASTM D 3350	WSDOT 9-05.23	Pipe Bursting or Steep Slope Installation
Profile Wall HDPE, Integral Bell Joints (Spiralite or Environmental Services approved equal)	Per Pipe Design, minimum class 100	ASTM F894 ASTM F477 ASTM D3350	Requires prior approval from Environmental Services. Additional design requirements may apply.	Large Diameter

Galvanized, aluminized, and/or corrugated iron or steel pipes are not allowed within the public right-of-way or as a connection to the Municipal system.

#### **10.1.1.2 Private Pipes Outside the Right-of-Way**

In addition to the pipe materials listed in Section 10.1.1.2, privately owned pipe located outside the right-of-way may also be one of the following:

- Corrugated aluminum pipe (12-gauge or thicker)
- Aluminum spiral rib pipe (12-gauge or thicker)
- Aluminized Type 2 corrugated steel (meeting AASHTO treatment M274 and M 56, 12-gauge or thicker)
- Corrugated high density polyethylene pipe (CPEP) - single wall, fully corrugated meeting AASHTO standard M-252 (permitted only outside public right-of-way and for use in temporary storm sewer systems and as downspout/footing/yard drain collectors on private property)
- Polyvinyl chloride (PVC) sewer pipe (SDR 35, meeting requirements of ASTM D3034).
- Polypropylene pipe (PP) conforming to the following requirements:

- Pipe diameter 12"-30" shall be dual wall pipe conforming to ASTM F2736
- Pipe diameter 30"-60" shall be triple wall pipe conforming to ASTM F2764.
- Fittings shall be factory welded, injection molded or PVC.
- Single wall pipe (12"-30" in diameter) conforming to ASTM F2736 may be used for slotted or perforated pipe installations.

### 10.1.2 Pipe Sizes

- Pipe sizes for pipe systems to be maintained by the City of Tacoma shall be 12-inch, 15-inch, 18-inch, 21-inch, 24-inch, and 30-inch. For pipes larger than 30-inch increasing increments of 6-inch intervals shall be used (36-inch, 42-inch, 48-inch, etc.).
- Pipes smaller than 12-inch may only be used for privately maintained systems, or to match the diameter of existing downstream mains, or as approved in writing by Environmental Services.
- Catch basin leads shall be a minimum of 12-inch.
- Roof drains may use pipe as small as 3-inch, and small driveway drains may use pipe as small as 6-inch. Pipes under 10-inch may require capacity analysis if requested by Environmental Services.

### 10.1.3 Changes in Pipe Sizes

- Pipe direction changes or size increases or decreases are only allowed at manholes and catch basins.
- Where a minimal fall is necessary between inlet and outlet pipes in a structure, pipes must be aligned vertically by one of the following in order of preference:
  - a. Match pipe crowns
  - b. Match 80% diameters of pipes
  - c. Match pipe inverts or use City approved drop inlet connection

### 10.1.4 Pipe Alignment and Depth

- Pipes must be laid true to line and grade with no curves, bends, or deflections in any direction.

**Exception:** *Vertical deflections in HDPE and ductile iron pipe with flanged restrained mechanical joint bends (not greater than 30%) on steep slopes are allowed provided the pipe adequately drains with a minimum velocity of 2 feet per second (fps).*
- A break in grade or alignment or changes in pipe material shall occur only at catch basins or manholes.
- For the standard main alignment refer to the City of Tacoma Design Manual.
- The standard depth for new mains measures six (6) feet from the center of the pipe to the main street surface.
- The project engineer shall consult with the City for the potential of a future extension of the storm system. In this case, the City may require modifications to the depth or alignment.



- Connections to the storm system shall be made at a structure. Tributary connections shall be made at 90° to the main. Slight variations may be allowed.
- Pipes shall be allowed to cross under retaining walls as specifically approved in writing by Environmental Services when no other reasonable alternatives exist.

### **10.1.5 Pipe Slopes and Velocities**

- A minimum slope for all pipes shall be 0.5%. Slopes less than 0.5% may be allowed on a case-by-case basis provided calculations are provided to demonstrate that a minimum velocity of 2 feet per second can be maintained at full flow.
- Maximum slopes, velocities, and anchor spacings are shown in Table 3 - 19. If velocities exceed 15 feet per second for the conveyance system design event described in Chapter 9, provide anchors and/or restrained joints at bends and junctions.

### **10.1.6 Pipes on Steep Slopes**

**NOTE:** This section does not apply to catch basin leads that utilize a single pipe section. Typically, below-ground installations do not require anchors. Consult with Environmental Services for steep below-ground installations.

- A basis of design shall be required for all mains installed at a slope greater than 20%.
- Slopes 20% or greater shall require all drainage to be piped from the top to the bottom of the slope in High Density Polyethylene (HDPE) pipe (butt-fused) or ductile iron pipe welded or mechanically restrained. Additional anchoring design is required for these pipes.
- Above-ground installation is required on slopes greater than 40% to minimize disturbance to steep slopes, unless otherwise approved in writing by Environmental Services.
- HDPE pipe systems longer than 100 feet must be anchored at the upstream end if the slope exceeds 20% or as required by Environmental Services.
- Above ground installations of HDPE shall address the high thermal expansion/contraction coefficient of the pipe material. An analysis shall be completed to demonstrate that the system as designed will tolerate the thermal expansion of the pipe material.

**Table 3 - 19: Maximum Pipe Slopes, Velocities and Anchor Requirements**

Pipe Materials	Pipe Slope Above Which Pipe Anchors Required and Minimum Anchor Spacing	Max Slope Allowed	Max.Velocity Full Flow
Spiral Rib <sup>(1)</sup> , PVC <sup>(1)</sup> , CPEP-singlewall	20% (1 anchor per 100 L.F. of pipe)	30% <sup>(3)</sup>	30 fps
Concrete <sup>(1)</sup> or CPEP-smooth interior <sup>(1)</sup>	10% (1 anchor per 50 L.F. of pipe)	20% <sup>(3)</sup>	30 fps
Ductile Iron <sup>(4)</sup>	40% (1 anchor per pipe section)	None	None
HDPE <sup>(2)</sup>	50% (1 anchor per 100 L.F. of pipe – cross slope installations may be allowed with additional anchoring and analysis)	None	None
Concrete	10% 1 anchor per 50 L.F. of pipe	20%	30 fps
Notes:			
(1) Not allowed in landslide hazard areas.			
(2) Butt-fused pipe joints required. Above-ground installation is required on slopes greater than 40% to minimize disturbance to steep slopes.			
(3) Maximum slope of 200% allowed for these pipe materials with no joints (one section) if structures are provided at each end and the pipes are properly grouted or otherwise restrained to the structures.			
(4) Restrained joints required on slopes greater than 25%. Above-ground installation is required on slopes greater than 40% to minimize disturbance to steep slopes.			
Key:			
PVC = Polyvinyl chloride pipe			
CPEP = Corrugated high density polyethylene pipe			
HDPE = High density polyethylene pipe			

## 10.1.7 Pipe Clearances

### 10.1.7.1 10.1.7.1 Horizontal Clearance

It is the applicant's responsibility to contact individual utilities to determine additional separation requirements. The most stringent separation requirement shall apply.

#### *Pipes within the Right-of-Way*

- A minimum of 5 feet horizontal separation shall be maintained between the stormwater main and all wastewater mains, other stormwater mains, and laterals that run parallel to mains.
- Separation requirements from water mains shall comply with Tacoma Water requirements.
- Separation must also comply with proper bedding requirements.

### ***Pipes on Private Property***

- Horizontal separation on private property shall comply with applicable building codes, plumbing codes, and Tacoma Water requirements.
- Horizontal separation from wastewater laterals shall comply with the City of Tacoma Side Sewer and Sanitary Sewer Availability Manual.
- Separation must also comply with proper bedding requirements.

#### **10.1.7.2 Vertical Clearance**

### ***Pipes within the Right-of-Way***

- Where crossing an existing or proposed utility, the alignment of the storm system shall be such that the two systems cross as close to perpendicular as possible.
- Where crossing a stormwater main, provide a minimum of 18 inches of vertical separation.
- Separation requirements from water mains shall comply with Tacoma Water requirements.
- The minimum vertical separation for a stormwater main crossing any other utility shall be 6 inches.
- Where vertical separation of two parallel systems exceeds the horizontal separation, additional horizontal separation may be required to provide future access to the deeper system.
- Separation must also comply with proper bedding requirements.

### ***Pipes on Private Property***

- The minimum vertical separation for stormwater lines crossing any other utility shall be 6 inches.
- Horizontal separation from wastewater laterals shall comply with the City of Tacoma Side Sewer and Sanitary Sewer Availability Manual.
- Separation must also comply with proper bedding requirements.

#### **10.1.8 Pipe Cover**

- Suitable pipe cover over storm pipes in road rights-of-way shall be calculated for H-20 loading by the Project Engineer. Pipe cover is measured from the finished grade elevation down to the top of the outside surface of the pipe. Pipe manufacturer's recommendations are acceptable if verified by the Project Engineer.
- Minimum cover for all pipe types shall be three feet in areas subject to vehicular traffic unless manufacturer's recommendations or calculations are provided from the Professional Engineer to demonstrate that the pipe can withstand less cover. Cover shall be measured from the top edge of the pipe to the final grade.
- Pipe cover in areas not subject to vehicular loads, such as landscape planters and yards, may be reduced to a 1-foot minimum.

## **10.2 Culvert Specifications**

Culverts are relatively short segments of pipe of circular, elliptical, rectangular, or arch cross section and typically convey flow under road embankments or driveways. Culverts installed in

stream and natural drainages shall meet the City's Critical Areas Preservation Ordinance and any fish passage requirements of the Washington State Department of Fish and Wildlife.

### 10.2.1 Inlets and Outlets

All inlets and outlets in or near roadway embankments must be flush with and conforming to the slope of the embankments.

- For culverts 18-inch diameter and larger, the embankment around the culvert inlet shall be protected from erosion by **rock lining or riprap** as specified in Table 3 - 21, except the length shall extend at least 5 feet upstream of the culvert, and the height shall be at or above the design headwater elevation.
- **Inlet structures**, such as concrete headwalls, may provide a more economical design by allowing the use of smaller entrance coefficients and, hence, smaller diameter culverts. When properly designed, they will also protect the embankment from erosion and eliminate the need for rock lining.
- In order to maintain the stability of roadway embankments, concrete headwalls, wingwalls, or tapered inlets and outlets may be required if **right-of-way or easement constraints** prohibit the culvert from extending to the toe of the embankment slopes. All inlet structures or headwalls installed in or near roadway embankments must be flush with and conforming to the slope of the embankment.
- **Debris barriers (trash racks)** are required on the inlets of all culverts that are over 60 feet in length and are 12 to 36 inches in diameter. This requirement also applies to the inlets of pipe systems. See Figure 3 - 34 for a debris barrier detail. Exceptions are culverts on Type 1 or 2 streams.
- For culverts 18-inch diameter and larger, the receiving channel of the outlet shall be protected from erosion by **rock lining** specified in Table 3 - 21, except the height shall be one foot above maximum tailwater elevation or one foot above the crown per Figure 3 - 37, whichever is higher.
- Closed depressions are required to have two outlets in the event one outlet clogs. This could be a second outlet pipe or an emergency spillway.

## 10.3 Open Channel Specifications

### 10.3.1 Natural Channels

*Natural channels* are defined as those that have occurred naturally due to the flow of surface waters, or those that, although originally constructed by human activity, have taken on the appearance of a natural channel including a stable route and biological community. They may vary hydraulically along each channel reach and should be left in their natural condition, wherever feasible or required, in order to maintain natural hydrologic functions and wildlife habitat benefits from established vegetation.

### 10.3.2 Constructed Channels

*Constructed channels* are those constructed or maintained by human activity and include bank stabilization of natural channels. Constructed channels shall be either vegetation-lined, rock lined, or lined with appropriately bioengineered vegetation.

- **Vegetation-lined channels** are the most desirable of the constructed channels when properly designed and constructed. The vegetation stabilizes the slopes of the channel, controls erosion of the channel surface, and removes pollutants. The channel storage,

low velocities, water quality benefits, and greenbelt multiple-use benefits create significant advantages over other constructed channels. The presence of vegetation in channels creates turbulence, which results in loss of energy and increased flow retardation; therefore, the design engineer must consider sediment deposition and scour, as well as flow capacity, when designing the channel.

- **Rock-lined channels** are necessary where a vegetative lining will not provide adequate protection from erosive velocities. They may be constructed with riprap, gabions, or slope mattress linings. The rock lining increases the turbulence, resulting in a loss of energy and increased flow retardation. Rock lining also permits a higher design velocity and therefore a steeper design slope than in grass-lined channels. Rock linings are also used for erosion control at culvert and storm drain outlets, sharp channel bends, channel confluences, and locally steepened channel sections.
- **Bioengineered vegetation lining** is a desirable alternative to the conventional methods of rock armoring. *Soil bioengineering* is a highly specialized science that uses living plants and plant parts to stabilize eroded or damaged land. Properly designed bioengineering systems are capable of providing a measure of immediate soil protection and mechanical reinforcement. As the plants grow they produce vegetative protective cover and a root reinforcing matrix in the soil mantle. This root reinforcement serves several purposes:
  - a. The developed anchor roots provide both shear and tensile strength to the soil, thereby providing protection from the frictional shear and tensile velocity components to the soil mantle during the time when flows are receding and pore pressure is high in the saturated bank.
  - b. The root mat provides a living filter in the soil mantle that allows for the natural release of water after the high flows have receded.
  - c. The combined root system exhibits active friction transfer along the length of the living roots. This consolidates soil particles in the bank and serves to protect the soil structure from collapsing and the stabilization measures from failing.

### 10.3.3 Open Channel Design Criteria

- **Open channels** shall be designed to provide required conveyance capacity while minimizing erosion and allowing for aesthetics, habitat preservation, and enhancement. See Section 9.3 for open channel sizing criteria.
- **An access easement for maintenance** is required along all constructed channels located on private property. Required easement widths and building setback lines vary with channel top width.
- **Channel cross-section geometry** shall be trapezoidal, triangular, parabolic, or segmental as shown in Figure 3 - 38 through Figure 3 - 40. Side slopes shall be no steeper than 3:1 for vegetation-lined channels and 2:1 for rock-lined channels.
- **Vegetation-lined channels** shall have bottom slope gradients of 6% or less and a maximum velocity at design flow of 5 fps (see Table 3 - 20).
- **Rock-lined channels or bank stabilization of natural channels** shall be used when design flow velocities exceed 5 feet per second. Rock stabilization shall be in accordance with Table 3 - 20 or stabilized with bioengineering methods as described above in "Constructed Channels."

## 10.4 Structures

All structures to be maintained by the City of Tacoma shall meet the requirements of the City of Tacoma Design Manual. All other structures must meet WSDOT standards.

The following criteria shall be used when designing a conveyance system that utilizes catch basins or manholes:

- Connections to the storm system shall be made at a structure. Tributary connections shall be made at 90° to the main. Slight variations may be allowed.
- The maximum surface run between catch basins shall not exceed 350 feet. Catch basin locations shall be based upon the quantitative downstream analysis when required (see Minimum Requirement #10)
- The maximum distance between manholes is 350 linear feet. If the minimum pipe slope requirements of 0.5% cannot be met, the maximum distance between manholes shall be 200 linear feet.
- Catch basin (or manhole) size shall be determined by pipe diameter and orientation at the structure. A plan view of the junction structure, drawn to scale, will be required when more than four pipes enter the structure on the same plane, or if angles of approach and clearance between pipes is of concern. The plan view (and sections if necessary) must demonstrate that the minimum distance requirements between knockouts per the Standard Plans can be maintained.
- Catch basins shall be Type 1, Type 1L, or Type 2 catch basins conforming to WSDOT Standard Plans B.5.2-01, B.5.4-01, or B.10.20-01
- Type 1 & Type 1L basin heights shall not exceed eight (8) feet.
- Type 2 (48-inch minimum diameter) catch basins or manholes shall be used at the following locations or for the following situations:
  - When overall structure height exceeds 8 feet.
  - When all pipes tying into the structure exceed the limits set for Type 1 structures.
  - All Type 2 catch basins shall be specifically approved by Environmental Services.
- In sag conditions, a combination inlet per WSDOT Standard Plan B-25.20-01 is required.
- Catch basin grates shall be vaned grates per WSDOT Standard Plans B-30.30-01 or WSDOT Standard Plan B-30.40.01.
- Where existing catch basins are modified, grates may be required to be replaced with vaned grates. Environmental Services will make the final determination based on the condition of the existing grate.
- To accommodate maintenance, do not place quarry spalls around catch basin inlet.
- The maximum slope of ground surface for a radius of 5 feet around a catch basin grate shall be 3:1. The preferred slope is 5:1 to facilitate maintenance access.
- All manholes shall either be Type 1 or 2 concrete manholes with concentric cones as shown on the City of Tacoma Standard Plans No. SU-17 and No. SU-18. The use of Type 3 concrete manholes requires prior approval from Environmental Services. The use of non-concrete manholes requires prior approval from Environmental Services.
- The base of all manholes shall be channeled in accordance with City of Tacoma Standard Plans No. SU-17, No. SU-18, and No. SU-19. City of Tacoma manholes do not have sumps unless they are a specialized manhole such as flow control manholes.

- All manhole frames and covers that will be publicly maintained shall be as shown on City of Tacoma Standard Plan No. SU-22.
- All manholes located in sidewalk sections shall have a solid locking cover. The sidewalk section shall be a minimum of six (6) inches thick in the vicinity of the manhole.
- Environmental Services may require additional manholes to have locking lids on a case-by-case basis. Examples of additional locations that may require locking lids includes gulches, undeveloped right-of-way, and low drainage areas.
- Catch basins and manholes shall be designed for H-20 loading. Environmental Services may require structural design calculations be submitted for review and approval.
- Catch basins leads shall be no longer than 50 feet unless specifically approved by Environmental Services.
- Catch basins shall be located:
  - Such that the inlet is placed next to the face of the curb and at an elevation to collect stormwater runoff (the structure offset shown on the plans shall be to center of grate, not center of structure to ensure grate location is appropriate);
  - At the low point of any sag vertical curve or grade break where the grade of roadway transitions from a negative to a positive grade;
  - Prior to any intersection such that a minimal amount of water flows across the intersection, through a curb ramp, or around a street return;
  - Prior to transitions from a typical crown to a full warp through a downhill grade;
  - Upstream of curb ramps outside of the wing of the curb ramp.
- Catch basins shall not be located:
  - In areas of expected pedestrian traffic;
  - In crosswalks;
  - In the wheel path of vehicles;
  - In driveways;
  - In graveled areas or high sediment generating areas unless pretreatment per Volume 5 is provided;
  - Where they will conflict with other utilities.
- Where the City of Tacoma Curb Ramp Installation Matrix or other department review or requirements require a new curb ramp, a replacement of a curb ramp, or an upgrade to a curb ramp, drainage shall be provided to ensure water does not flow across the curb ramp. This may require the installation of new catch basins or manholes, the removal and replacement of existing catch basins or manholes or revisions to the storm system as necessary to ensure appropriate stormwater mitigation.
- Manholes shall be located:
  - At the intersection of any stormwater system.
  - At the dead end of a conveyance system.
  - At any alignment and grade changes.
  - At catch basin lead connections.

- As otherwise required by Environmental Services.
- All catch basins, inlets, etc. shall be marked. Environmental Services has curb markers available for both public and private projects. Contact Environmental Services at 253.591.5588 to obtain curb markers for the project.
- Changes in pipe direction, or increases or decreases in size, shall only be allowed at structures.
- For Type 1 and 1L, catch basin to catch basin connections shall not be allowed.
- Bubble up systems shall not be allowed.



## 10.5 System Connections

- Connections to a pipe system shall be made only at catch basins or manholes. No wyes or tees are allowed except on private roof/footing/yard drain systems on pipes 8 inches in diameter, or less. Where wyes and tees are utilized, clean-outs shall be required upstream of each wye and tee. Where multiple pipes are present in a manhole or catch basin, the applicant shall submit a detail showing that the minimum distances between openings can be met.
- Extensions of catch basin leads shall connect to the same pipe type, or replacement of the lead or addition of a structure is required.
- A flexible pipe-to-manhole connector shall be utilized in all connections of rigid and flexible pipes to new precast concrete manholes to provide a watertight joint between the pipe and manhole. The connector shall be “Kor-N-Seal” with “Wedge Korband” or Engineer-approved equivalent.
- Connections to catch basins shall use sand collars.
- Connections to existing brick manholes may be allowed on a case by case basis. Manhole replacement may be required by Environmental Services based upon the condition of the existing manhole.
- Connections to structures and mains shall be at 90°. Slight variations may be allowed.
- Fall through manhole structures shall be 0.1 foot. Pipes of different diameters shall be aligned vertically in manholes by one of the following methods, listed in order of preference:
  - a. Match pipe crowns
  - b. Match 80% diameters of pipes.
  - c. Match pipe inverts or use City approved drop inlet connection.
- Where inlet pipes are significantly higher than outlet pipes special design features may be required.
- Drop connections shall be allowed for catch basin leads only. Catch basin leads shall connect below the cone of the manhole.
- Private connections to the City storm system shall be at a drainage structure (i.e. catch basin or manhole) and only if capacity exists at the design storm event. Tee connections into the side of a pipe shall not be permitted.
- Roof downspouts may be infiltrated or dispersed in accordance with the provisions of Chapter 2. Infiltration and dispersion shall be evaluated first. If infiltration and dispersion are not feasible, roof drains may be discharged through the curb per Section 2.6 into the roadway gutter or connected into a drainage structure. Roof downspouts may **not** be connected directly into the side of a storm drainage pipe.
- Roof drainage shall not be connected to, or allowed to infiltrate into the footing drain system. Footing drains may connect to the roof drain system provided the following are met:
  - the connection of roof and footing drain discharge lines be a minimum of five feet horizontally from the building,
  - the footing drain invert elevation be a minimum of 6 inches above the roof invert elevation at the connection point, and

- a yard drain, cleanout or other structure to allow for access and maintenance be installed at the connection points.

### 10.6 Debris Barriers

Trash racks on City-owned pipes are only required for culverts, pond outlet pipes or as otherwise directed by Environmental Services. Debris barriers (trash racks) are required on all pipes entering a pipe system. See Figure 3 - 34 for required debris barriers on pipe ends outside of roadways and for requirements on pipe ends (culverts) projecting from driveways or roadway side slopes.

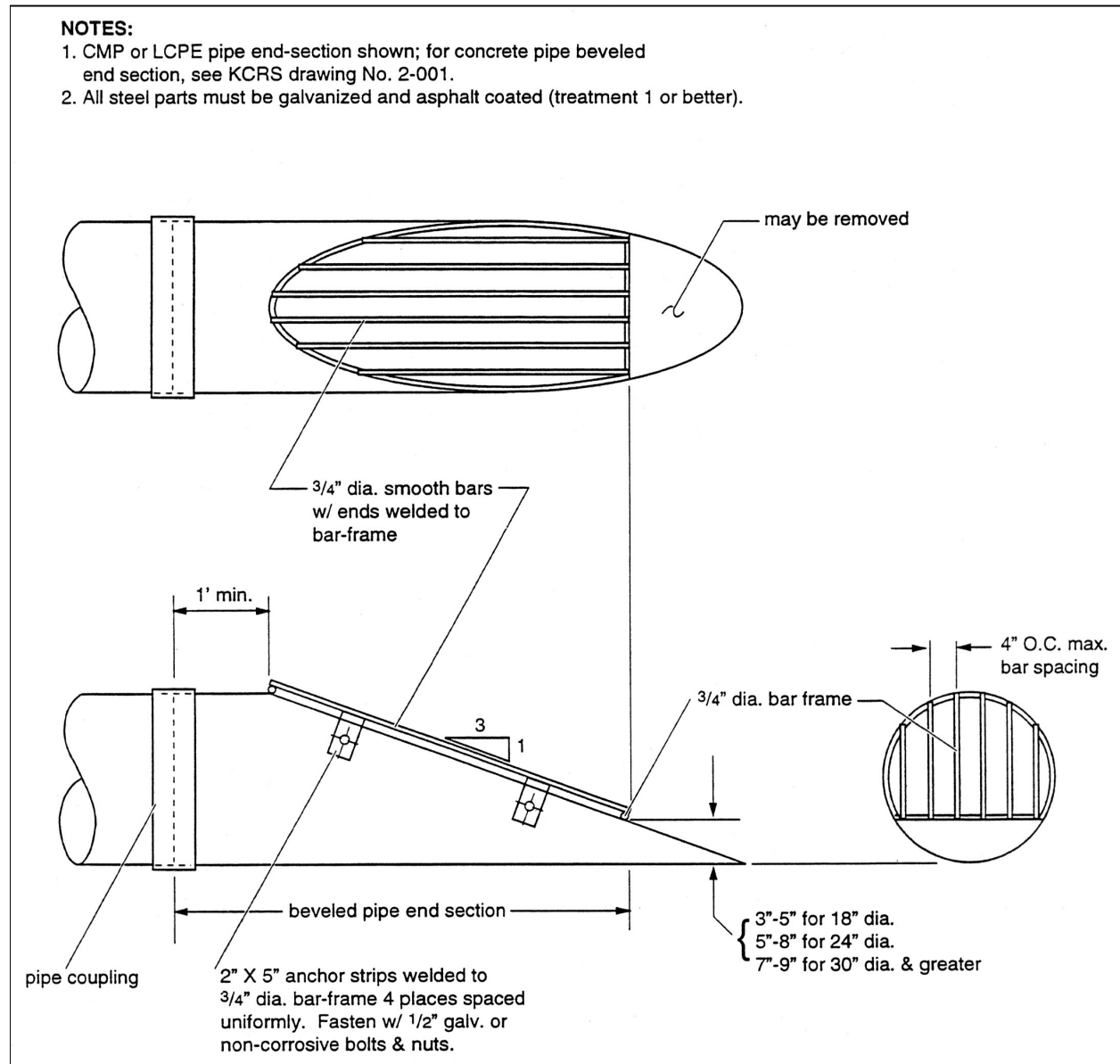


Figure 3 - 34. Debris Barrier

**Table 3 - 20: Channel Protection**

Velocity at Design Flow (fps)		Required Protection		
Greater than	Less than or equal to	Type of Protection	Thickness	Min. Height Above Design Water Surface
0	5	Grass lining or bioengineered lining	N/A	0.5 foot
5	8	Rock lining <sup>(1)</sup> or bioengineered lining	1 foot	1 foot
8	12	Riprap <sup>(2)</sup>	2 feet	2 feet
12	20	Slope mattress gabion, etc.	Varies	2 feet
<p>(1) Rock Lining shall be reasonable well graded as follows:  Maximum stone size: 12 inches  Median stone size: 8 inches  Minimum stone size: 2 inches</p> <p>(2) Riprap shall be reasonably well graded as follows:  Maximum stone size: 24 inches  Median stone size: 16 inches  Minimum stone size: 4 inches</p> <p><b>Note:</b> Riprap sizing is governed by side slopes on channel, assumed to be approximately 3:1.</p>				

## 10.7 Riprap Design<sup>1</sup>

Proper riprap design requires the determination of the median size of stone, the thickness of the riprap layer, the gradation of stone sizes, and the selection of angular stones, which will interlock when placed. Research by the U.S. Army Corps of Engineers has provided criteria for selecting the **median stone weight,  $W_{50}$**  (Figure 3 - 35). If the riprap is to be used in a highly turbulent zone (such as at a culvert outfall, downstream of a stilling basin, at sharp changes in channel geometry, etc.), the median stone  $W_{50}$  should be increased from 200% to 600% depending on the severity of the locally high turbulence. The thickness of the riprap layer should generally be twice the **median stone diameter ( $D_{50}$ )** or at least equivalent to the diameter of the maximum stone. The riprap should have a reasonably well-graded assortment of stone sizes within the following gradation:

$$1.25 \leq D_{max}/D_{50} \leq 1.50$$

$$D_{15}/D_{50} = 0.50$$

$$D_{min}/D_{50} = 0.25$$

1. From a paper prepared by M. Schaefer, Dam Safety Section, Washington State Department of Ecology.

### **Riprap Filter Design**

Riprap should be underlain by a sand and gravel filter (or filter fabric) to keep the fine materials in the underlying channel bed from being washed through the voids in the riprap. Likewise, the filter material must be selected so that it is not washed through the voids in the riprap. Adequate filters can usually be provided by a reasonably well graded sand and gravel material where:

$$D_{15} < 5d_{85}$$

The variable  $d_{85}$  refers to the sieve opening through which 85% of the material being protected will pass, and  $D_{15}$  has the same interpretation for the filter material. A filter material with a  $D_{50}$  of 0.5 mm will protect any finer material including clay. Where very large riprap is used, it is sometimes necessary to use two filter layers between the material being protected and the riprap.

#### **Example:**

What embedded riprap design should be used to protect a streambank at a level culvert outfall where the outfall velocities in the vicinity of the downstream toe are expected to be about 8 fps.

From Figure 3 - 35,  $W_{50} = 6.5$  lbs, but since the downstream area below the outfall will be subjected to severe turbulence, increase  $W_{50}$  by 400% so that:

$$W_{50} = 26 \text{ lbs, } D_{50} = 8.0 \text{ inches}$$

The gradation of the riprap is shown in Figure 3 - 36, and the minimum thickness would be 1 foot (from Table 3 - 20); however, 16 inches to 24 inches of riprap thickness would provide some additional insurance that the riprap will function properly in this highly turbulent area.

Table 3 - 36 shows that the gradation curve for ASTM C33, size number 57 coarse aggregate (used in concrete mixes), would meet the filter criteria. Applying the filter criteria to the coarse aggregate demonstrates that any underlying material whose gradation was coarser than that of concrete sand would be protected.

For additional information and procedures for specifying filters for riprap, refer to *the Army Corps of Engineers Manual EM 1110-2-1601, Hydraulic Design of Flood Control Channels*, Paragraph 14, "Riprap Protection."

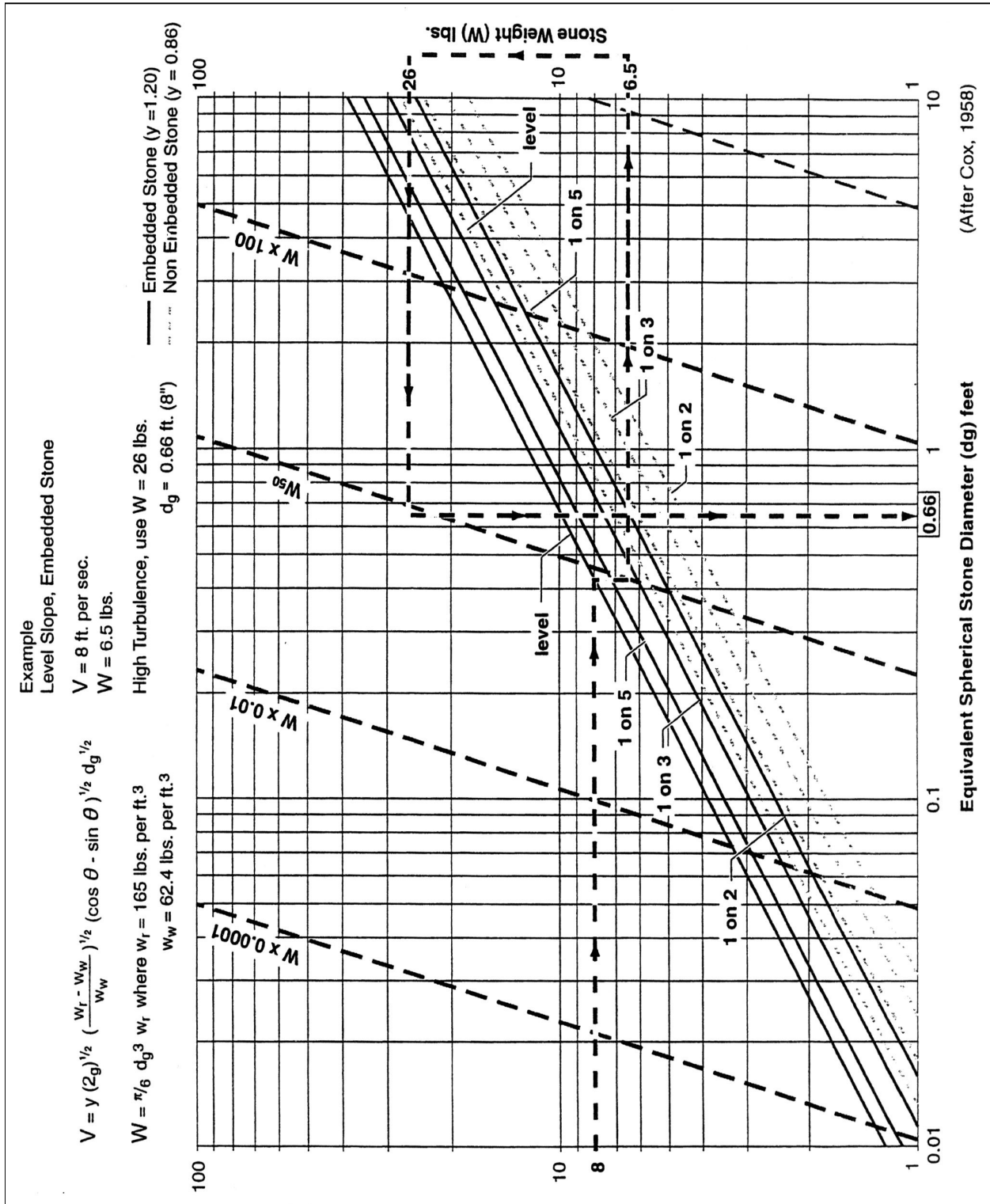


Figure 3 - 35. Mean Channel Velocity vs Medium Stone Weight (W50) and Equivalent Stone Diameter

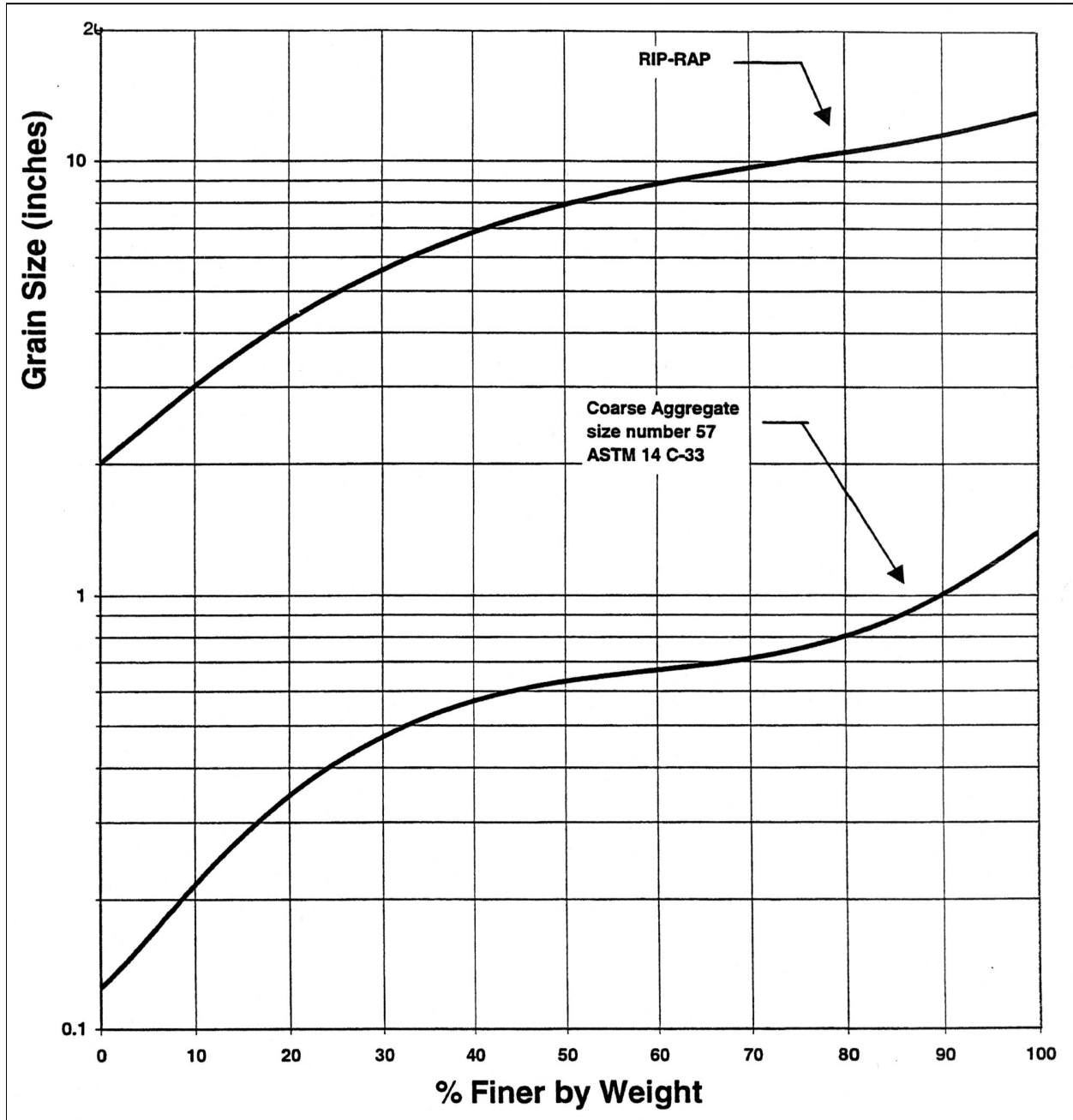


Figure 3 - 36. Riprap Gradation Curve

## Chapter 11 Outfall Systems

This section presents the methods, criteria and details for analysis and design of outfall systems. Properly designed outfalls are critical to reducing the chance of adverse impacts as the result of concentrated discharges from pipe systems and culverts, both onsite and downstream. Outfall systems include piping, rock splash pads, flow dispersal trenches, gabion or other energy dissipaters.

### 11.1 Outfall Design Criteria

All outfalls must be provided with an appropriate outlet / energy dissipation structure such as a dispersal trench, gabion outfall, or rock splash pad (see Figure 3 - 37) as specified below and in Table 3 - 21.

No erosion or flooding of downstream properties shall result from discharge from an outfall.

**Table 3 - 21: Rock Protection at Outfalls**

Discharge Velocity at Design Flow in Feet per Second (fps)	Required Protection (Minimum Dimensions)				
	Type	Thickness	Width	Length	Height
0 – 5	Rock lining <sup>(1)</sup>	1 foot	Diameter + 6 feet	8 feet or 4 x diameter, whichever is greater	Crown + 1 foot
>5 - 10	Riprap <sup>(2)</sup>	2 feet	Diameter + 6 feet or 3 x diameter, whichever is greater	12 feet or 4 x diameter, whichever is greater	Crown + 1 foot
>10 - 20	Gabion outfall	As required	As required	As required	Crown + 1 foot
>20	Engineered energy dissipater required				

**NOTES:**

<sup>(1)</sup> **Rock lining** shall be quarry spalls with gradation as follows:

- Passing 8-inch square sieve: 100%
- Passing 3-inch square sieve: 40 to 60% maximum
- Passing 3/4-inch square sieve: 0 to 10% maximum

<sup>(2)</sup> **Riprap** shall be reasonably well graded with gradation as follows:

- Maximum stone size: 24 inches (nominal diameter)
- Median stone size: 16 inches
- Minimum stone size: 4 inches

Riprap sizing is based on outlet channel side slopes of approximately 3:1.



### 11.1.1 Energy dissipation

- For freshwater outfalls with a design velocity greater than 10 fps, a gabion dissipater or engineered energy dissipater may be required. The gabion outfall detail shown in Figure 3 - 40 is illustrative only. A design engineered to specific site conditions must be developed.
- In marine waters, rock splash pads and gabion structures are not recommended due to corrosion and destruction of the structure, particularly in high energy environments. Diffuser Tee structures, such as that depicted in Figure 3 - 41, are also not generally recommended in or above the intertidal zone. They may be acceptable in low bank or rock shoreline locations. Generally, tightlines trenched to extreme low water or dissipation of the discharge energy above the ordinary high water line are preferred. Outfalls below extreme low water may still need an energy dissipation device (e.g., a tee structure) to prevent erosion in the immediate vicinity of the discharge.
- Engineered energy dissipaters, including stilling basins, drop pools, hydraulic jump basins, baffled aprons, and bucket aprons, are required for outfalls with design velocity greater than 20 fps. These should be designed using published or commonly known techniques found in such references as Hydraulic Design of Energy Dissipaters for Culverts and Channels, published by the Federal Highway Administration of the United States Department of Transportation; Open Channel Flow, by V.T. Chow; Hydraulic Design of Stilling Basins and Energy Dissipaters, EM 25, Bureau of Reclamation (1978); and other publications, such as those prepared by the Soil Conservation Service (now Natural Resource Conservation Service).
- Alternate mechanisms may be allowed with written approval of Environmental Services. Alternate mechanisms shall be designed using sound hydraulic principles with consideration of ease of construction and maintenance.
- Mechanisms that reduce velocity prior to discharge from an outfall are encouraged. Some of these are drop manholes and rapid expansion into pipes of much larger size. Other discharge end features may be used to dissipate the discharge energy. An example of an end feature is the use of a Diffuser Tee with holes in the front half, as shown in Figure 3 - 41.

Stormwater outfalls submerged in a marine environment can be subject to plugging due to biological growth and shifting debris and sediments. Regular maintenance is needed to ensure the outfall continues to function as designed.

The in-stream sample gabion mattress energy dissipater may not be acceptable within the ordinary high water mark of fish-bearing waters or where gabions will be subject to abrasion from upstream channel sediments. A gabion basket located outside the ordinary high water mark should be considered for these applications.

### 11.1.2 Flow dispersion

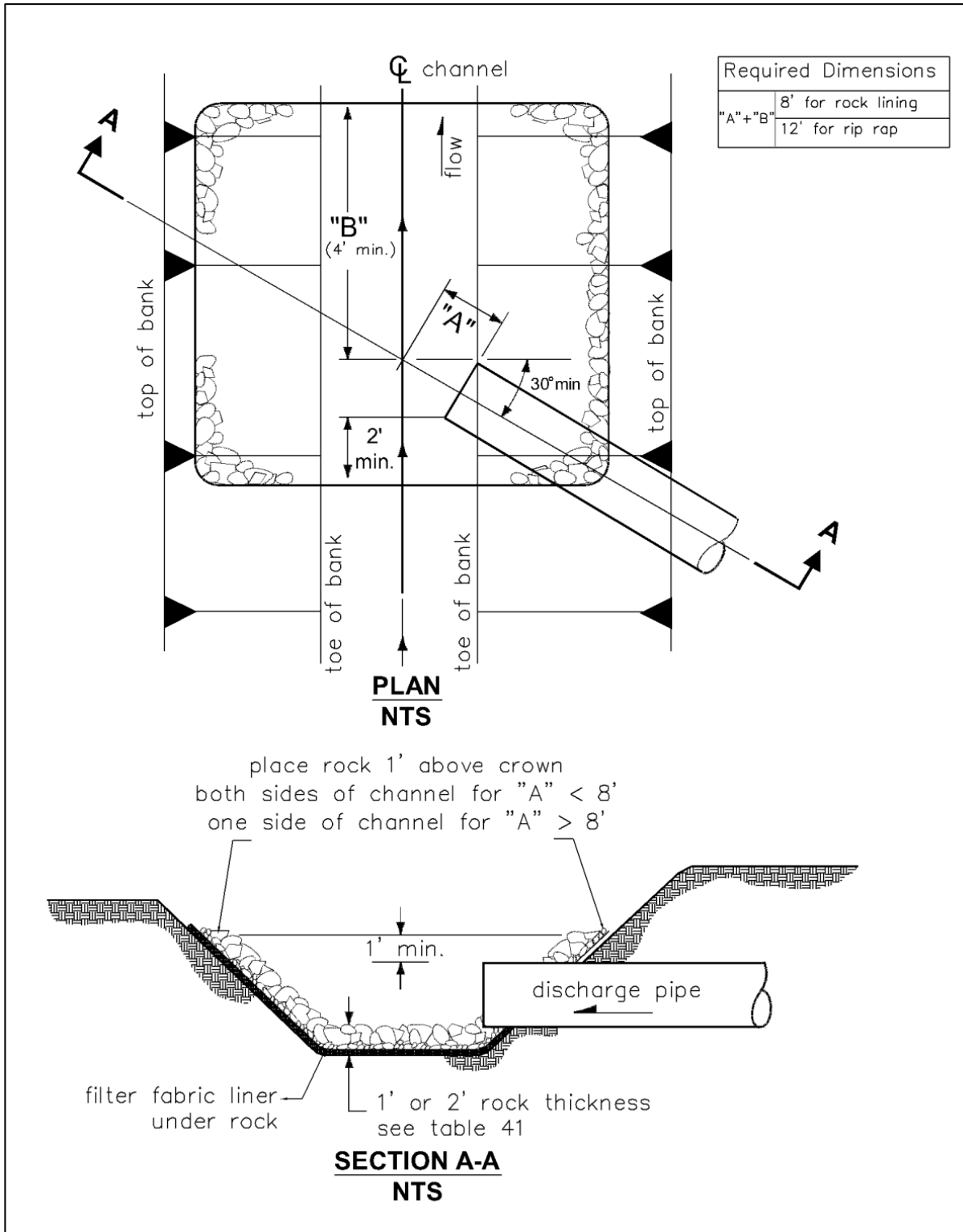
- The flow dispersal trenches shown in Figure 3 - 38 and Figure 3 - 39 shall not be used unless both criteria below are met:
  - An outfall is necessary to disperse concentrated flows across uplands where no conveyance system exists and the natural (existing) discharge is unconcentrated; and
  - The 100-year peak discharge rate is less than or equal to 0.5 cfs.
- Flow dispersion may be allowed for discharges greater than 0.5 cfs, providing that adequate design details and calculations for the dispersal trench to demonstrate that discharge will be sheet flow are submitted and approved by Environmental Services. For

dispersion trenches discharging more than 0.5 cfs, additional vegetated flowpath may be required.

- For the dispersion trenches shown in Figure 3 - 38 and Figure 3 - 39, a vegetated flowpath of at least 25 feet in length must be maintained between the outlet of the trench and any property line, structure, stream, wetland, or impervious surface. A vegetated flowpath of at least 50 feet in length must be maintained between the outlet of the trench and any steep slope. Sensitive area buffers may count towards flowpath lengths.
- All dispersion systems shall be at least 10 feet from any structure or property line. If necessary, setbacks shall be increased from the minimum 10 feet in order to maintain a 1H:1V side slope for future excavation and maintenance.
- Dispersion systems shall be setback from sensitive areas, steep slopes, slopes 20% or greater, landslide hazard areas, and erosion hazard areas as governed by the Tacoma Municipal Code or as outlined in this manual, whichever is more restrictive.
- For sites with multiple dispersion trenches, a minimum separation of 10 feet is required between flowpaths. Environmental Services may require a larger separation based upon site conditions such as slope, soil type and total contributing area.
- Runoff discharged towards landslide hazard areas must be evaluated by a geotechnical engineer or a licensed geologist, hydrogeologist, or engineering geologist. The discharge point shall not be placed on or above slopes 20% (5H:1V) or greater or above erosion hazard areas without evaluation by a geotechnical engineer or qualified geologist and City approval.

Please refer to the Tacoma Municipal Code for additional requirements. TMC 13.11 Critical Areas Protection Ordinance may contain additional requirements depending upon the project proposal. A Hydraulic Project Approval (Chapter 77.55 RCW), an Army Corps of Engineers permit, and other state and federal approvals may be required for any work within or below the ordinary high water mark.

Other provisions of that RCW or the Hydraulics Code - Chapter 220-110 WAC may also apply.



**Figure 3 - 37. Pipe/Culvert Outfall Discharge Protection**

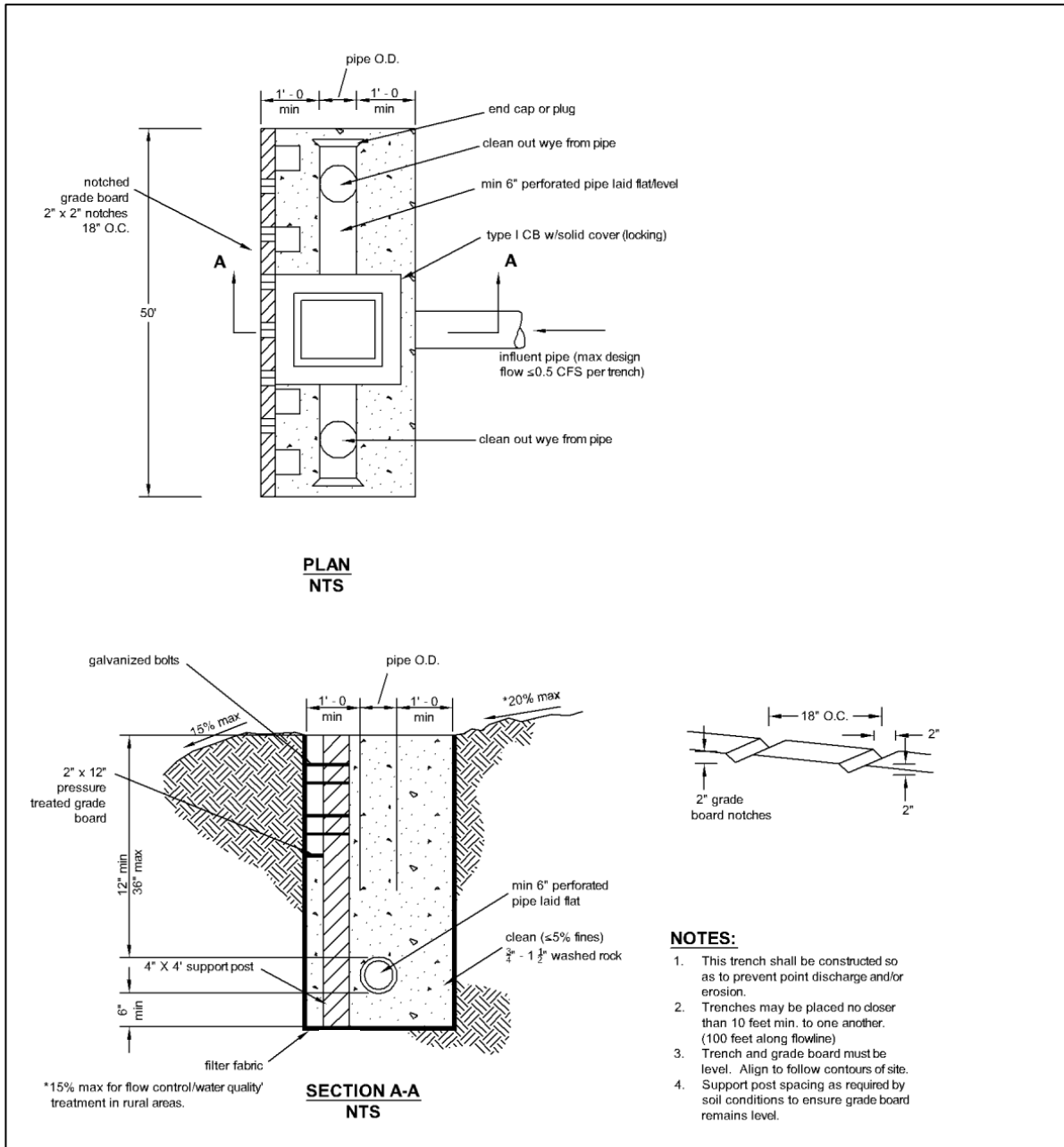
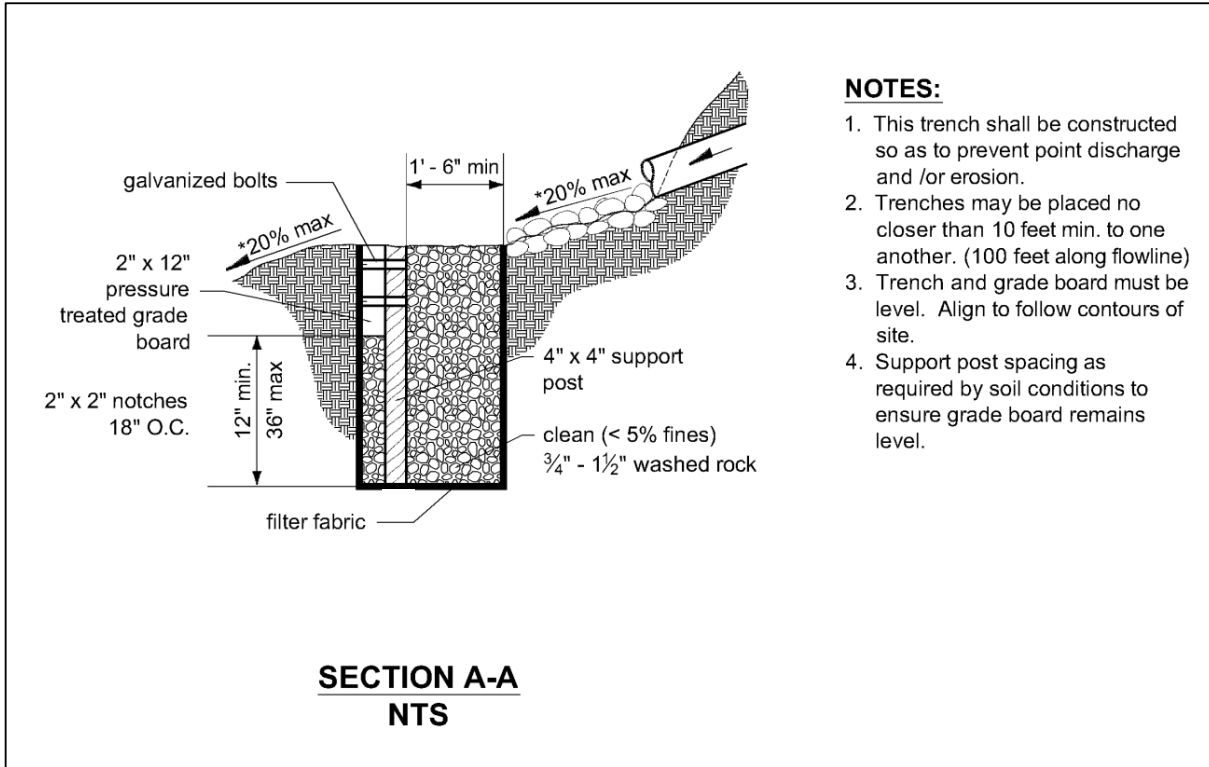


Figure 3 - 38. Flow Dispersal Trench



**NOTES:**

1. This trench shall be constructed so as to prevent point discharge and /or erosion.
2. Trenches may be placed no closer than 10 feet min. to one another. (100 feet along flowline)
3. Trench and grade board must be level. Align to follow contours of site.
4. Support post spacing as required by soil conditions to ensure grade board remains level.

**Figure 3 - 39. Alternative Flow Dispersal Trench**

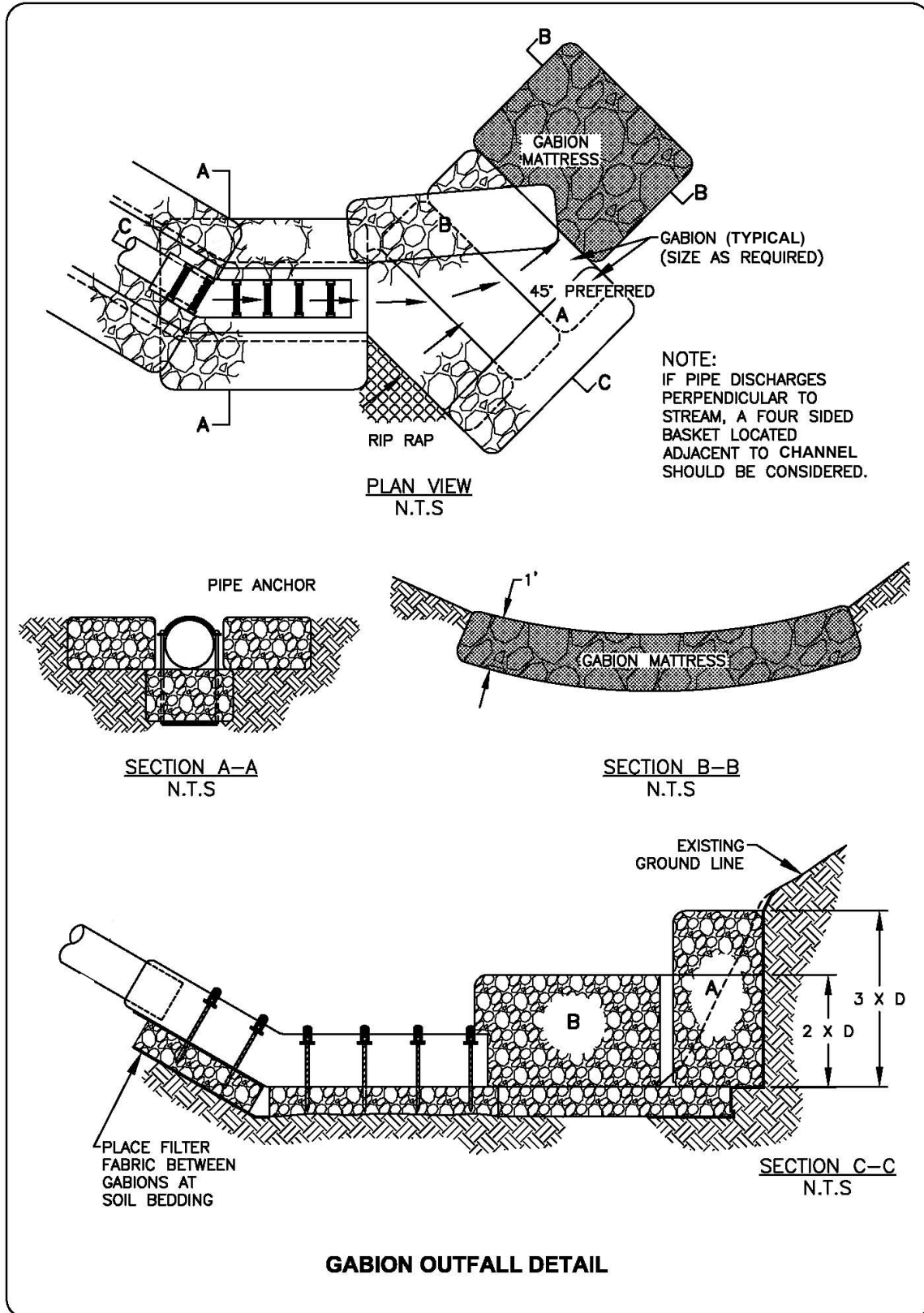


Figure 3 - 40. Gabion Outfall Detail

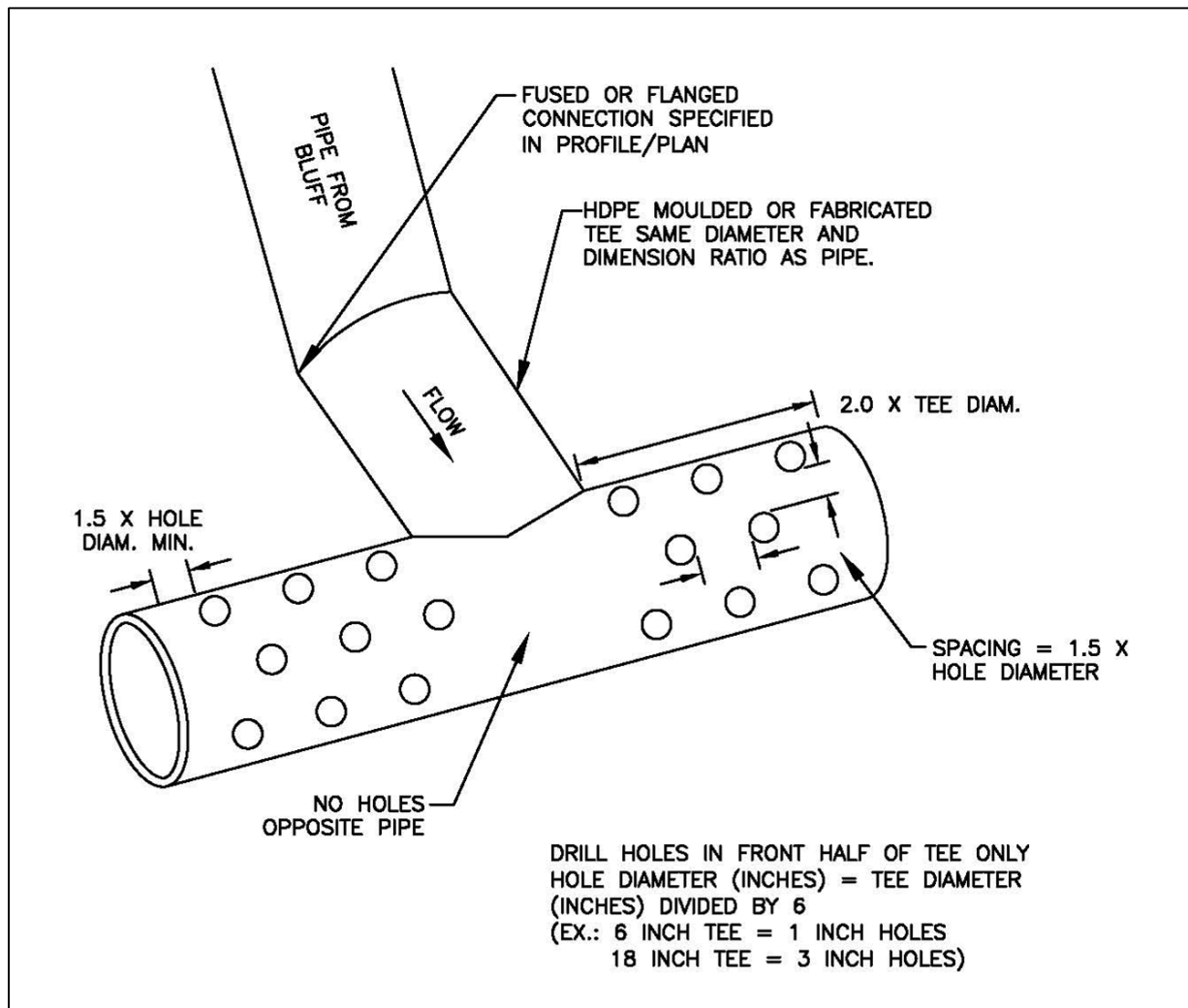


Figure 3 - 41. Diffuser TEE (an example of energy dissipating end feature)

## 11.2 Tightline Systems

- Outfall tightlines may be installed in trenches with standard bedding on slopes up to 20%. In order to minimize disturbance to slopes greater than 20%, it is recommended that tightlines be placed at grade with proper pipe anchorage and support.
- Except as indicated above, tightlines or conveyances that traverse the marine intertidal zone and connect to outfalls must be buried to a depth sufficient to avoid exposure of the line during storm events or future changes in beach elevation. If non-native material is used to bed the tightline, such material shall be covered with at least 3 feet of native bed material or equivalent.
- High density polyethylene pipe (HDPE) tightlines must be designed to address the material limitations, particularly thermal expansion and contraction and pressure design, as specified by the manufacturer.
- Due to the ability of HDPE tightlines to transmit flows of very high energy, special consideration for energy dissipation must be made. Details of a sample gabion mattress

energy dissipater have been provided as Figure 3 - 40. Flows of very high energy will require a specifically engineered energy dissipater structure.

- Tightline systems may be needed to prevent aggravation or creation of a downstream erosion problem.
- Tightline systems shall have appropriate anchoring designed, both along the slope and to provide anchoring for the entire system.

### **11.3 Habitat Considerations**

- New pipe outfalls can provide an opportunity for low-cost fish habitat improvements. For example, an alcove of low-velocity water can be created by constructing the pipe outfall and associated energy dissipater back from the stream edge and digging a channel, over widened to the upstream side, from the outfall to the stream. Overwintering juvenile and migrating adult salmonids may use the alcove as shelter during high flows. Potential habitat improvements should be discussed with the Washington Department of Fish and Wildlife biologist prior to inclusion in design.
- Bank stabilization, bioengineering and habitat features may be required for disturbed areas.
- Outfall structures should be located where they minimize impacts to fish, shellfish, and their habitats.
- The City's Critical Area Preservation Ordinance and other state and federal regulations may regulate activities in these areas.



**This Page Intentionally Left Blank**

## Chapter 12 Pump Systems

Pump systems are only allowed if it is determined that gravity systems are not feasible and as specifically approved in writing by Environmental Services. Feasibility of all other methods of gravity conveyance, infiltration and dispersion shall first be investigated and demonstrated to be infeasible in the following order of preference:

1. Infiltration of stormwater onsite.
2. Dispersion of stormwater on site.
3. Gravity connection to the City storm drainage system.
4. Pumping to a gravity system.

### 12.1 Design Criteria

The pump system must convey, at a minimum, the peak design flow for the 25-year 24-hour rainfall event. Pump capacity plus system storage or overflow, must convey or store the 100-year, 24-hour storm event.

### 12.2 Pump Requirements

Proposed pump systems must meet the following minimum requirements:

- The gravity-flow components of the drainage system to and from the pump system must be designed so that pump failure does not result in flooding of a building or emergency access or overflow to a location other than the natural discharge point for the project site.
- The pump system must have a dual pump (alternating) equipped with emergency back-up power OR a single pump may be provided without back-up power if the design provides the 100-year 24-hour storage volume.
- Pumps, wiring, and control systems shall be intrinsically safe per IBC requirements.
- All pump systems must be equipped with an external pump failure and high water alarm system.
- The pump system will serve only one lot or business owner.
- The pump system must be privately owned and maintained.
- The pump system shall not be used to circumvent any other City of Tacoma drainage requirements. Construction and operation of the pump system shall not violate any City of Tacoma requirements.
- All pump systems shall provide a transition from pressure line to gravity line prior to connection to the City system or curb. The transition shall be made at a cleanout or similar structure located on private property if possible.

### 12.3 Additional Requirements

Private pumped stormwater systems will require the following additional items:

- Operations and Maintenance Manual describing the system itself and all required maintenance and operating instructions, including procedures to follow in the event of a power outage. All the requirements of Volume 1 Section 4.1 shall be included in the Operations and Maintenance manual.

- The property owner must enter into a Covenant and Easement Agreement with the City. The Covenant and Easement Agreement must be recorded to the property title with Pierce County.

All fees associated with preparing and recording documents and placing the Notice to Title shall be the responsibility of the applicant.

### **12.3.1 Submittal Requirements**

The following information shall be provided for review:

- Plan view of proposed system
- Profile view of proposed system
- Detail of holding tank including pump on and off elevations
- Method of transition from pressure line to gravity line and location of transition from pressure line to gravity line
- Cut sheets and specifications for:
  - Pump (including pump performance curve)
  - Holding tank
  - Control panel
  - Audio visual alarm
- Engineering calculations, including:
  - System head loss calculations
  - Flow rate and volume as calculated from single event model using appropriate design event (see Section 12.1).
  - Appropriate flow rate and head characteristics plotted on the pump performance curve
  - Velocity calculations for the proposed diameter and type of pipe
  - Frequency and duration of pumping cycles
  - 100-year, 24-hour storage volume (if proposing a single pump)
- Operation and Maintenance Manual describing the system itself and all required maintenance and operating instructions, including procedures to follow in the event of a power outage. All requirements of Volume 1, Section 4.1 shall be included in the Operation and Maintenance Manual.

## 12.4 Sump Pumps

The above pump requirements do not apply to internal sump pumps. However, internal sump pumps **do require** a permit prior to connection to the City storm drainage system.

- Sump pumps shall be sized to properly remove water from basements and crawl spaces.
- Sump pumps shall NOT be connected to the sanitary sewer system.
- Consult the pump manufacturer or an engineer for appropriate sizing of a sump pump.
- Contaminated water shall not be discharged to the City stormwater system.
- All pump systems shall provide a gravity break prior to discharge to the City system or curb.

Environmental Services may review pump installations and may require cut sheets, proposed layout, proposed connection to the City system, and sizing calculations.

**This Page Intentionally Left Blank**

## Chapter 13 Easements, Access, and Dedicated Tracts

All publicly owned, manmade drainage facilities and conveyances and all natural channels on the project site used for conveyance of altered flows due to development (including swales, ditches, stream channels, lake shores, wetlands, potholes, estuaries, gullies, ravines, etc.) shall be located within easements or dedicated tracts as required by the City.

Easements shall contain the natural features and facilities and shall allow City access for purposes of inspection, maintenance, repair or replacement, flood control, water quality monitoring, and other activities permitted by law.

For easements dedicated to the City for the purpose of storm drainage, it will not be allowable to place, plant or construct any permanent structures in, upon or under the easement area unless specifically approved in writing by the City of Tacoma's Environmental Services Director, or designee. Such approval shall be drafted as an Addendum to the easement and recorded with the Pierce County Auditor's Office. Permanent structure shall mean any concrete foundation, concrete slab, wall, rockery, building, deck, overhanging structure, fill material, tree, recreational sport court, carport, portable or non-portable shed, private utilities, fence, or any other improvement that restricts or unreasonably interferes with the City's access to install, construct, operate, inspect, maintain, remove, repair, and replace the public utilities within the easement area. Permanent structures shall not mean flowers, ground cover and shrubs, (provided they are less than 3 feet in height), lawn, grass, asphalt paving, or gravel.

Preliminary project planning should account for the potential loss of buildable area or the need to purchase more property as a result of drainage facilities and their required easements/tracts.

### 13.1 Stormwater Facilities

#### 13.1.1 Public

When not located in the city right of way, all drainage facilities such as ponds, infiltration systems, and water quality treatment systems to be maintained by the City shall be located in separate tracts dedicated to the City. Tracts and easement must also maintain appropriate setbacks as required for each BMP.

#### 13.1.2 Private

Privately owned facilities shall be located outside of dedicated public right-of-way areas. A covenant and easement agreement is required for all proposed private stormwater facilities to ensure proper maintenance and access. The document shall be recorded on title. The City shall review and approve all covenant and easement agreements before they are signed and recorded.

### 13.2 Conveyance Systems

#### 13.2.1 Public

All publicly maintained conveyance systems shall be located in dedicated tracts, drainage easements, or public rights-of-way. **Public storm drainage easements shall be a minimum of 20 feet in width.** Consult Section 10.1.4 of this volume and the City of Tacoma Design Manual for pipe alignment requirements.

All pipes and channels must be centered within the easement. Easement widths may have to be adjusted for pipes greater than 5 feet in diameter and channels with top widths greater than 5 feet.

The depth or proximity of steep slopes to the public system may necessitate a larger easement requirement for future excavation and maintenance purposes. Consult with Table 3 - 22 for appropriate widths based on depth of pipe.

**Table 3 - 22: Storm Drain Easement Widths**

Channel Width	Easement Width
Channels ≤ 10' Wide	Channel Width + 15' on one side
Channels > 10' Wide	Channel Width + 15' on both sides
Pipe Invert Depth	Easement Width
< 10'	20'
10' - 15'	25'
15' - 20'	30'
> 20'	40'

Greater width may be required for large diameter pipe or unfavorable site conditions.  
 Pipe shall be installed in center of easement.  
 If two pipes are to be installed in an easement, add 10 feet to the easement widths listed above. Use the deeper of the two pipes in selecting the easement width from this table. Install pipes with 10 feet of horizontal clearance between them.

**13.2.2 Private**

All privately maintained conveyance systems serving multiple lots/owners shall be located in dedicated tracts, drainage easements, or private roadways with appropriate easements. Any new conveyance system located on private property designed to convey drainage from other private properties must be located in a private drainage easement granted to the contributors of stormwater to said systems. The easement shall permit access for maintenance or replacement in the case of failure.

Unless prohibited by topography or existing site conditions, new conveyance system alignments, on private property, must be located in drainage easements that are adjacent and parallel to property lines.

The depth or proximity of a private system to slopes 20% or greater may necessitate a larger easement for future excavation and maintenance purposes. Typically this requires a 1:1 slope from the bottom of the trench.

Private easement width shall be based upon pipe diameter, depth of pipe and maintenance access. Table 3 - 22 can be used as guidance to determine appropriate easement width.

### **13.3 Maintenance Access**

A minimum 15-foot wide access easement shall be provided to drainage facilities from a public street or right-of-way. Access easements shall be surfaced with a minimum 12-foot width of crushed rock, or other approved surface to allow year-round equipment access to the facility.

Maintenance access must be provided for all manholes, catch basins, vaults, or other underground drainage facilities operated by the City. Maintenance shall be through an access easement or dedicated tract. These must include a constructed access road per the requirements of Section 7.1.2 of this volume.

Privately maintained facilities must be readily accessible. Provide documentation as to how these facilities will be accessed.



**This Page Intentionally Left Blank**

## Appendix A Tacoma Design Storm

**Table 3 - 23: Design Storm Precipitation Values**

Return Frequency 24-Hour Storm Event (Years)	Precipitation (Inches)
0.5	1.44
2	2.0
5	2.5
10	3.0
25	3.5
50	3.5
100	4.1

The depth of a 7-day, 100-year storm can be determined in one of three ways:

- Use 12 inches for the lowland areas between sea level and 650 MSL.
- Use the U.S. Department of Commerce Technical Paper No. 49, "Two- to Ten-Day Precipitation for Return Periods of 2 to 100 Years in the Contiguous United States."
- Use the U.S. Department of Commerce NOAA Atlas 2, "Precipitation Frequency Atlas of the Western United States," Volume IX – Washington, 24-hour, 100-year Isopluvials and add 6.0 inches to the appropriate isopluvial for the project area.

**This Page Intentionally Left Blank**

## Appendix B Soils Reports

This Appendix describes when a site-specific soils report is required and the requirements of that soils report.

### B.1 All Projects

- A site specific soils report is required for the design of all infiltration facilities. See the sections below for specific soils report requirements.
- If infiltration is being utilized to meet Minimum Requirement #6, Minimum Requirement #7 or Minimum Requirement #8, a site specific soils report is required. See Section B.8 for soils report requirements.
- A site-specific soils report is required to obtain flow credits for Best Management Practices that manage stormwater by infiltration and that allow flow credits. Refer to each individual BMP for flow credit evaluation. To obtain flow credits, the best management practices shall be designed per the SWMM requirements.

### B.2 BMP L602: Downspout Full Infiltration Systems

A soils report per Section B.2.1 is required to design a downspout infiltration trench or downspout dry well per BMP L602 – Full Downspout Infiltration. Downspout full infiltration facilities shall be designed per Volume 3, Section 2.3.3.

A soils report per Section B.2.1 is required to complete the determination of infeasibility or to design the system if the minimum infiltration trench length or a minimum drywell size will fit on the project site. If the setback and site constraint criteria per Volume 3, Section 2.3.3.2 or the design standards per BMP L602a – Infiltration Trenches (Volume 3, Section 2.3.3.4) or BMP L602b – Dry Wells (Volume 3, Section 2.3.3.5) can be met assuming the minimum trench length per Table 3-2 or the minimum dry well size per Table 3-3 a soils report is required to determine if an infiltration facility is infeasible,.

#### B.2.1 Soils Report Requirements for Downspout Full Infiltration

The soils report must, at a minimum:

- Be prepared by one of the following\*: professional soils scientist certified by the Soil Science Society of America (or an equivalent national program), a Washington State licensed onsite sewage designer, other suitably-trained professional engineer, geologist, hydrogeologist, or engineering geologist registered in the State of Washington, or persons working under the supervision of one of the soils professionals listed above;
- Contain at least one soils log a minimum of 4 feet deep (from proposed grade) and at least one foot below expected bottom elevation of the facility taken at the location of the proposed infiltration system (if it is unknown where the infiltration system will likely be sited, it may be necessary to take several soils logs to ensure appropriate site coverage);
- Identify the USDA textural class of the soil horizon through the depth of the log;
- Note any evidence of high groundwater level, such as mottling; and
- Note the depth to seasonal high groundwater table or other impermeable layer.

\*Each professional should know the limits of their professional licensing. Contact your state or local licensing board for additional information.

### **B.3 BMP L604: Perforated Stubouts**

A soils report per section B.3.1 is required to design a perforated stub-out connection. Perforated stubouts shall be designed per Volume 3, Section 2.5.3

A soils report per section B.3.1 is required if citing that a perforated stubout connection is not feasible due to depth to the seasonal high groundwater table.

#### **B.3.1 Soils Report Requirements for Perforated Stubouts**

The soils report must, at a minimum

- Be prepared by one of the following\*: professional soils scientist certified by the Soil Science Society of America (or an equivalent national program), a Washington State licensed onsite sewage designer, other suitably-trained professional engineer, geologist, hydrogeologist, or engineering geologist registered in the State of Washington, or persons working under the supervision of one of the soils professionals listed above;
- Contain at least one soils log a minimum of 4 feet deep (from proposed grade) and at least one foot below expected bottom elevation of the facility taken at the location of the proposed infiltration system (if it is unknown where the infiltration system will likely be sited, it may be necessary to take several soils logs to ensure appropriate site coverage);
- Identify the USDA textural class of the soil horizon through the depth of the log;
- Note any evidence of high groundwater level, such as mottling; and
- Note the depth to seasonal high groundwater table or other impermeable layer.

\*Each professional should know the limits of their professional licensing. Contact your state or local licensing board for additional information.

### **B.4 BMP L601: Rain Gardens**

A soils report per section B.4.1 is required to design a rain garden. Rain gardens shall be designed per Volume 6, Section 2.2.2.1.

A soils report per Section B.5.1 is required if citing that a rain garden is not feasible because of infiltration capability of native soil or distance to seasonal high groundwater table or other impermeable layer.

#### **B.4.1 Soils Report Requirements for Rain Gardens**

The soils report must, at a minimum:

- Be prepared by one of the following\*: professional soils scientist certified by the Soil Science Society of America (or an equivalent national program), a Washington state licensed onsite sewage designer, other suitably-trained professional engineer, geologist, hydrogeologist, or engineering geologist registered in the State of Washington, or persons working under the supervision of one of the soils professionals listed above;
- Contain at least one soils log a minimum of 4 feet deep (from proposed grade) and at least one foot below expected bottom elevation of the facility taken at the location of the proposed infiltration system (if it is unknown where the infiltration system will likely be sited, it may be necessary to take several soils logs to ensure appropriate site coverage);
- Identify the USDA textural class of the soil horizon through the depth of the log;
- Note any evidence of high groundwater level, such as mottling; and

- Note the depth to seasonal high groundwater table or other impermeable layer; and
- Identify the infiltration rate of the unsaturated vadose zone using methods outlined in Volume 3, Section 6.5 and Volume 5, Section 7.5. If the Soil Grain Size Analysis Method is proposed, the soils report must justify why the site soils are unconsolidated by glacial advance.

\*Each professional should know the limits of their professional licensing. Contact your state or local licensing board for additional information.

## **B.5 BMP L633: Permeable Pavement**

A soils report is required to design permeable pavement. A soils report per Section B.8 is required if permeable pavement is being used to meet Minimum Requirement #6, #7, or #8 or if citing that permeable pavement is not feasible for meeting the intent of Minimum Requirement #5 – List #2 (Volume 1, Section 3.4.5.6) because of infiltration capability of native soil or distance to seasonal high groundwater table or other impermeable table.

A soils report per Section B.5.1 can be used for the design of permeable pavement surfaces for single family/duplex projects and sidewalks installations (except those used to meet Minimum Requirement #6, #7, or #8). A soils report per Section B.8 is required for permeable pavement roads and permeable pavement surfaces on commercial/industrial sites.

### **B.5.1 Soils Report Requirements for Permeable Pavement Infeasibility for MR #5 – List #1**

The soils report must, at a minimum:

- Be prepared by one of the following\*: professional soils scientist certified by the Soil Science Society of America (or an equivalent national program), a Washington state licensed onsite sewage designer, other suitably-trained professional engineer, geologist, hydrogeologist, or engineering geologist registered in the State of Washington, or persons working under the supervision of one of the soils professionals listed above;
- Contain at least one soils log a minimum of 4 feet deep (from proposed grade) and at least one foot below expected bottom elevation of the facility taken at the location of the proposed infiltration system (if it is unknown where the infiltration system will likely be sited, it may be necessary to take several soils logs to ensure appropriate site coverage);
- Identify the USDA textural class of the soil horizon through the depth of the log;
- Note any evidence of high groundwater level, such as mottling; and
- Note the depth to seasonal high groundwater table or other impermeable layer; and
- Identify the infiltration rate of the unsaturated vadose zone using methods outlined in Volume 3, Section 6.5 and Volume 5, Section 7.5. If the Soil Grain Size Analysis Method is proposed, the soils report must justify why the site soils are not unconsolidated by glacial advance.

\*Each professional should know the limits of their professional licensing. Contact your state or local licensing board for additional information.

## **B.6 Bioretention**

A soils report per Section B.8 below is required for all bioretention facilities.

## **B.7 Soils Report Requirements for Infiltration Facilities for Stormwater Flow Control or Treatment and Infeasibility for Permeable Pavement to Meet Minimum Requirement #5 – List #2**

Any stormwater best management practice that uses infiltration to meet Minimum Requirements #6, #7 or #8 shall complete a site-specific soils report. Best Management Practices to meet Minimum Requirements #6, #7, and #8 can include facilities such as infiltration trenches, drywells, infiltration basins, bioretention, and permeable pavement.

The soils report shall be prepared by a Washington State licensed Professional Engineer or Professional Geologist with expertise.

The soils report, at a minimum, must:

- Meet the test hole and/or boring requirements of:
  - Volume 3, Section 6.4.2 or Volume 5, Section 7.4.2;
  - Volume 6, Section 2.2.2.2.5.1 (for bioretention facilities)
  - Volume 6, Section 2.2.2.5.7 (for permeable pavement)
- Characterize each soil unit (soils of the same texture, color, density, compaction, consolidation, or permeability) encountered and include:
  - Percent clay content (include type of clay, if known)
  - Color/Mottling
  - Variations and nature of stratification; and
- Note the depth to seasonal high groundwater table or other impermeable layer; and
- Note any evidence of high groundwater level, such as mottling; and
- For infiltration facilities that will be used for stormwater treatment:
  - Include physical and chemical testing per Volume 5, Section 7.6.6 or Volume 6, Section 2.2.2.5.5 (for permeable pavement).
- Identify the infiltration rate of the unsaturated vadose zone using methods outlined in Volume 3, Section 6.5 and Volume 5, Section 7.5. If the Soil Grain Size Analysis Method is proposed, the soils report must justify why the site soils are not unconsolidated by glacial advance.

In addition, as required by Environmental Services, groundwater monitoring and /or a mounding analysis may be required per Volume 3, Section 6.4.4.

# Volume 4 - Source Control BMPs

## Table of Contents

Purpose of this Volume . . . . .	4-1
Content and Organization of this Volume . . . . .	4-1
<b>Chapter 1 Frequently Asked Questions . . . . .</b>	<b>4-3</b>
1.1 Applicability . . . . .	4-3
1.2 Pollutants of Concern . . . . .	4-3
1.2.1 pH . . . . .	4-3
1.2.2 Total Suspended Solids . . . . .	4-3
1.2.3 Oils and Greases . . . . .	4-3
1.2.4 Oxygen-demanding Substances . . . . .	4-3
1.2.5 Metals . . . . .	4-4
1.2.6 Bacteria and Viruses . . . . .	4-4
1.2.7 Nutrients . . . . .	4-4
1.2.8 Toxic Organic Compounds . . . . .	4-4
1.2.9 Other Chemicals and Substances . . . . .	4-4
1.3 Types of Source Control BMPs . . . . .	4-5
1.3.1 Operational BMPs . . . . .	4-5
1.3.2 Structural BMPs . . . . .	4-5
<b>Chapter 2 Worksheet for Commercial and Industrial Activities . . . . .</b>	<b>4-7</b>
<b>Chapter 3 BMPs for Homeowners . . . . .</b>	<b>4-11</b>
3.1 Automobile Washing (for Single-Family Residences) . . . . .	4-11
3.1.1 Required BMPs . . . . .	4-11
3.1.2 Suggested BMPs . . . . .	4-11
3.1.2.1 At Home: . . . . .	4-11
3.1.2.2 Away from Home: . . . . .	4-12
3.2 Automobile Maintenance . . . . .	4-12
3.2.1 Required BMPs . . . . .	4-12
3.2.2 Suggested BMPs . . . . .	4-12
3.3 Storage of Solid Wastes and Food Wastes . . . . .	4-13
3.3.1 Required BMPs . . . . .	4-13
3.3.2 Suggested BMPs . . . . .	4-13
3.4 Composting . . . . .	4-13
3.4.1 Required BMPs . . . . .	4-13
3.4.2 Suggested BMPs . . . . .	4-14
3.5 Yard Maintenance and Gardening . . . . .	4-14
3.5.1 Required BMPs . . . . .	4-14
3.5.2 Suggested BMPs . . . . .	4-14
3.6 Swimming Pool and Spa Cleaning and Maintenance . . . . .	4-15
3.6.1 Required BMPs . . . . .	4-15
3.6.2 Suggested BMPs . . . . .	4-16
3.7 Household Hazardous Material Use, Storage, and Disposal . . . . .	4-16



- 3.7.1 Required BMPs . . . . . 4-16
- 3.7.2 Suggested BMPs . . . . . 4-16
- 3.8 General Home Maintenance . . . . . 4-17
  - 3.8.1 Required BMPs . . . . . 4-17
  - 3.8.2 Suggested BMPs . . . . . 4-17
- 3.9 Pet Waste . . . . . 4-18
  - 3.9.1 Required BMPs . . . . . 4-18
- Chapter 4 BMPs for Commercial and Industrial Activities . . . . . 4-19**
  - 4.1 BMPs for All Activities . . . . . 4-19
    - 4.1.1 Mandatory Operational BMPs . . . . . 4-19
    - 4.1.2 Mandatory Good Housekeeping BMPs . . . . . 4-20
    - 4.1.3 Mandatory Preventive Maintenance BMPs: . . . . . 4-20
    - 4.1.4 Additional Recommended BMPs: . . . . . 4-20
  - 4.2 BMP W100: Washing Best Management Practices . . . . . 4-21
    - 4.2.1 Cleaning or Washing of Tools, Equipment, and Machinery . . . . . 4-23
    - 4.2.2 Cleaning or Washing of Cooking Equipment . . . . . 4-23
    - 4.2.3 Building Structures and Related Equipment . . . . . 4-24
    - 4.2.4 Interior Washing Operations . . . . . 4-25
    - 4.2.5 Washing, Pressure Washing and Steam Cleaning of Vehicles . . . . . 4-26
  - 4.3 Transfer of Liquid or Solid Materials . . . . . 4-28
    - 4.3.1 BMP A201: Loading and Unloading Areas for Liquid or Solid Material . . . . . 4-28
      - 4.3.1.1 Description of Pollutant Sources . . . . . 4-28
      - 4.3.1.2 Required BMPs . . . . . 4-28
      - 4.3.1.3 Recommended BMPs: . . . . . 4-30
    - 4.3.2 BMP A202: Fueling at Dedicated Stations . . . . . 4-32
      - 4.3.2.1 Description of Pollutant Sources . . . . . 4-32
      - 4.3.2.2 Required BMPs . . . . . 4-32
    - 4.3.3 BMP A203: Vehicle Maintenance Activities . . . . . 4-32
      - 4.3.3.1 Description of Pollutant Sources . . . . . 4-32
      - 4.3.3.2 Required BMPs . . . . . 4-33
      - 4.3.3.3 Recommended BMPs . . . . . 4-33
    - 4.3.4 BMP A204: Mobile Fueling of Vehicles and Heavy Equipment . . . . . 4-34
      - 4.3.4.1 Description of Pollutant Sources . . . . . 4-34
      - 4.3.4.2 Required BMPs . . . . . 4-34
  - 4.4 Production and Application Activities . . . . . 4-37
    - 4.4.1 BMP A301: Concrete and Asphalt Mixing and Production at Stationary Sites . . . . . 4-37
      - 4.4.1.1 Description of Pollutant Sources . . . . . 4-37
      - 4.4.1.2 Required BMPs . . . . . 4-37
      - 4.4.1.3 Recommended BMPs . . . . . 4-38
    - 4.4.2 BMP A302: Concrete Pouring, Concrete Cutting, and Asphalt Application at Temporary Sites  
4-38
      - 4.4.2.1 Description of Pollutant Sources . . . . . 4-38
      - 4.4.2.2 Required BMPs . . . . . 4-38
      - 4.4.2.3 Recommended BMPs . . . . . 4-39
    - 4.4.3 BMP A303: Manufacturing and Post-Processing of Metal Products . . . . . 4-39
      - 4.4.3.1 Description of Pollutant Sources . . . . . 4-39
      - 4.4.3.2 Required BMPs . . . . . 4-39
      - 4.4.3.3 Recommended BMPs . . . . . 4-40
    - 4.4.4 BMP A304: Wood Treatment Areas . . . . . 4-40

4.4.4.1	Description of Pollutant Sources	4-40
4.4.4.2	Required BMPs	4-40
4.4.5	BMP A305: Commercial Composting	4-40
4.4.5.1	Description of Pollutant Sources	4-40
4.4.5.2	Required BMPs for Commercial Composting	4-41
4.4.5.3	Recommended BMPs for Commercial Composting	4-41
4.4.6	BMP A306: Landscaping and Lawn/Vegetation Management	4-41
4.4.6.1	Description of Pollutant Sources	4-41
4.4.6.2	Required BMPs for Landscaping	4-41
4.4.6.3	Recommended BMPs for Landscaping	4-42
4.4.6.4	Required BMPs for the Use of Pesticides	4-42
4.4.6.5	Recommended BMPs for the use of Pesticides	4-43
4.4.6.6	Required BMPs for Vegetation Management	4-44
4.4.6.7	Required BMPs for the Use of Fertilizers	4-45
4.4.7	BMP A307: Painting, Finishing and Coating of Vehicles, Boats, Buildings and Equipment	4-45
4.4.7.1	Description of Pollutant Sources	4-45
4.4.7.2	Required BMPs	4-45
4.4.7.3	Recommended BMPs	4-46
4.4.8	BMP A308: Commercial Printing Operations	4-46
4.4.8.1	Description of Pollutant Sources	4-46
4.4.8.2	Required BMPs	4-46
4.4.8.3	Recommended BMPs	4-47
4.4.9	BMP A309: Manufacturing Operations – Outside	4-47
4.4.9.1	Description of Pollutant Sources	4-47
4.4.9.2	Required BMPs	4-47
4.5	Storage and Stockpiling Activities	4-49
4.5.1	BMP A401: Storage or Transfer (Outside) of Solid Raw Materials, By-Products or Finished Products	4-49
4.5.1.1	Description of Pollutant Sources	4-49
4.5.1.2	Required BMPs	4-49
4.5.1.3	Recommended BMPs	4-50
4.5.2	BMP A402: Storage and Treatment of Contaminated Soils	4-50
4.5.2.1	Description of Pollutant Sources	4-50
4.5.2.2	Required BMPs	4-50
4.5.2.3	Recommended BMPs	4-51
4.5.3	BMP A403: Temporary Storage or Processing of Fruits or Vegetables	4-51
4.5.3.1	Description of Pollutant Sources	4-51
4.5.3.2	Required BMPs	4-51
4.5.4	BMP A404: Storage of Solid Wastes and Food Wastes	4-52
4.5.4.1	Description of Pollutant Sources	4-52
4.5.4.2	Required BMPs	4-52
4.5.4.3	Recommended BMPs	4-53
4.5.5	BMP A405: Farmer’s Markets	4-53
4.5.5.1	Description of Pollutant Sources	4-53
4.5.5.2	Required BMPs	4-53
4.5.6	BMP A406: Recyclers and Scrap Yards	4-54
4.5.6.1	Description of Pollutant Sources	4-54
4.5.6.2	Required BMPs	4-54
4.5.7	BMP A407: Treatment, Storage or Disposal of Dangerous Wastes	4-54
4.5.8	BMP A408: Storage of Liquid, Food Waste or Dangerous Waste Containers	4-55

- 4.5.8.1 Description of Pollutant Sources . . . . . 4-55
- 4.5.8.2 Required BMPs . . . . . 4-55
- 4.5.9 BMP A409: Storage of Liquids in Above-Ground Tanks . . . . . 4-57
  - 4.5.9.1 Description of Pollutant Sources . . . . . 4-57
  - 4.5.9.2 Required BMPs for All Tanks . . . . . 4-57
  - 4.5.9.3 Required BMPs for Single-walled Tanks . . . . . 4-58
  - 4.5.9.4 Required BMPs for Double-walled Tanks . . . . . 4-59
- 4.5.10 BMP A410: Parking and Storage for Vehicles and Equipment . . . . . 4-61
  - 4.5.10.1 Description of Pollutant Sources . . . . . 4-61
  - 4.5.10.2 Required BMPs . . . . . 4-61
- 4.6 Construction and Demolition Activities . . . . . 4-62
  - 4.6.1 BMP A501: Clearing, Grading and Preparation of Construction Sites . . . . . 4-62
  - 4.6.2 BMP A502: Demolition of Buildings . . . . . 4-62
    - 4.6.2.1 Description of Pollutant Sources . . . . . 4-62
    - 4.6.2.2 Required BMPs . . . . . 4-62
    - 4.6.2.3 Recommended BMPs . . . . . 4-63
  - 4.6.3 BMP A503: Building, Repair, Remodeling and Construction . . . . . 4-63
    - 4.6.3.1 Description of Pollutant Sources . . . . . 4-63
    - 4.6.3.2 Required BMPs . . . . . 4-63
    - 4.6.3.3 Recommended BMPs . . . . . 4-64
- 4.7 Dust Control, and Soil and Sediment Control . . . . . 4-65
  - 4.7.1 BMP A601: Dust Control at Disturbed Land Areas and Unpaved Roadways and Parking Lots  
4-65
    - 4.7.1.1 Description of Pollutant Sources . . . . . 4-65
    - 4.7.1.2 Required BMPs . . . . . 4-65
    - 4.7.1.3 Recommended BMPs for Roadways and Other Trafficked Areas . . . . . 4-65
    - 4.7.1.4 Recommended BMPs for Dust Generating Areas . . . . . 4-66
  - 4.7.2 BMP A602: Dust Control at Manufacturing Sites . . . . . 4-66
    - 4.7.2.1 Description of Pollutant Sources . . . . . 4-66
    - 4.7.2.2 Required BMPs . . . . . 4-66
    - 4.7.2.3 Recommended BMPs . . . . . 4-66
  - 4.7.3 BMP A603: Soil Erosion and Sediment Control at Industrial Sites . . . . . 4-67
    - 4.7.3.1 Description of Pollutant Sources . . . . . 4-67
    - 4.7.3.2 Required BMPs . . . . . 4-67
- 4.8 Other Activities . . . . . 4-68
  - 4.8.1 BMP A701: Commercial Animal Handling Areas . . . . . 4-68
    - 4.8.1.1 Description of Pollutant Sources . . . . . 4-68
    - 4.8.1.2 Required BMPs . . . . . 4-68
  - 4.8.2 BMP A702: Log Sorting and Handling . . . . . 4-68
    - 4.8.2.1 Description of Pollutant Sources . . . . . 4-68
    - 4.8.2.2 Ecology’s Baseline General Permit Requirements: . . . . . 4-69
  - 4.8.3 BMP A703: Boat Building, Mooring, Maintenance and Repair . . . . . 4-69
    - 4.8.3.1 Description of Pollutant Sources . . . . . 4-69
    - 4.8.3.2 Required BMPs . . . . . 4-70
    - 4.8.3.3 Recommended BMPs . . . . . 4-71
  - 4.8.4 BMP A704: Logging . . . . . 4-71
    - 4.8.4.1 Description of Pollutant Sources . . . . . 4-71
    - 4.8.4.2 Required BMPs . . . . . 4-72
    - 4.8.4.3 Recommended BMPs . . . . . 4-72
  - 4.8.5 BMP A705: Mining and Quarrying of Sand, Gravel, Rock, Peat, Clay and Other Materials . .  
4-72

4.8.5.1 Description of Pollutant Sources . . . . .	4-72
4.8.5.2 Required BMPs . . . . .	4-73
4.8.5.3 Recommended BMPs . . . . .	4-73
4.8.6 BMP A706: Swimming Pool and Spa Cleaning and Maintenance . . . . .	4-73
4.8.6.1 Description of Pollutant Sources . . . . .	4-73
4.8.6.2 Required BMPs . . . . .	4-73
4.8.6.3 Recommended BMP . . . . .	4-74
4.8.7 BMP A707: De-Icing and Anti-Icing Operations for Streets & Highways . . . . .	4-74
4.8.7.1 Description of Pollutant Sources . . . . .	4-74
4.8.7.2 Required BMPs . . . . .	4-74
4.8.7.3 Recommended BMPs . . . . .	4-74
4.8.8 BMP A708: Roof and Building Drains at Manufacturing and Commercial Buildings . . . . .	4-74
4.8.8.1 Description of Pollutant Sources . . . . .	4-74
4.8.8.2 Required BMPs . . . . .	4-75
4.8.9 BMP A709: Urban Streets . . . . .	4-75
4.8.9.1 Description of Pollutant Sources . . . . .	4-75
4.8.9.2 Required BMPs . . . . .	4-75
4.8.9.3 Recommended BMPs . . . . .	4-75
4.8.10 BMP A710: Railroad Yards . . . . .	4-76
4.8.10.1 Description of Pollutant Sources . . . . .	4-76
4.8.10.2 Required BMPs . . . . .	4-76
4.8.11 BMP A711: Maintenance of Utility Vaults . . . . .	4-77
4.8.11.1 Description of Pollutant Sources . . . . .	4-77
4.8.11.2 Required BMPs . . . . .	4-77
4.8.12 BMP A712: Maintenance of Roadside Ditches and Culverts . . . . .	4-77
4.8.12.1 Description of Pollutant Sources . . . . .	4-77
4.8.12.2 Required BMPs . . . . .	4-77
4.8.12.3 Recommended BMPs . . . . .	4-79
4.8.13 BMP A713: Spills of Oil and Hazardous Substances . . . . .	4-79
4.8.13.1 Description of Pollutant Sources . . . . .	4-79
4.8.13.2 Required BMPs . . . . .	4-79
4.8.13.3 Recommended BMPs . . . . .	4-80
4.8.13.4 Additional Links . . . . .	4-80
4.8.14 BMP A714: Water Reservoir, Transmission Mainline, Wellhead, and Hydrant Flushing Activities . . . . .	4-81
4.8.14.1 Description of Pollutant Sources . . . . .	4-81
4.8.14.2 Required BMPs . . . . .	4-81
4.8.14.3 Recommended BMPs . . . . .	4-81
4.8.15 BMP S101: Eliminate Illicit Storm Drainage System Connections . . . . .	4-81
4.8.16 BMP S102: Dispose of Contaminated Stormwater and Waste Materials Properly . . . . .	4-82
4.8.17 BMP S103: Discharge Process Wastewater to a Sanitary Sewer, Holding Tank, or Water Treatment System . . . . .	4-83
4.9 Cover and Surround Activities . . . . .	4-84
4.9.1 BMP S104: Cover the Activity with a Roof or Awning . . . . .	4-84
4.9.2 BMP S105: Cover the Activity with an Anchored Tarp or Plastic Sheet . . . . .	4-84
4.9.3 BMP S106: Pave the Activity Area and Slope to a Sump, Holding Tank, or Oil/Water Separator . . . . .	4-85
4.9.4 BMP S107: Surround the Activity Area with a Curb, Dike, or Berm or Elevate the Activity . . . . .	4-86
4.10 BMP S108: Implement Integrated Pest Management Measures . . . . .	4-88
4.11 BMP S109: Cleaning Catch Basins . . . . .	4-89

**Appendix A Quick Reference Phone Numbers . . . . .4-91**  
**Appendix B Recycling/Disposal of Vehicle Fluids and Other Wastes . . . . .4-93**  
**Appendix C Example of an Integrated Pest Management Program . . . . .4-95**  
**Appendix D Management of Street Wastes. . . . .4-99**  
    D.1 Street Waste Liquids . . . . .4-99  
    D.2 Street Waste Solids . . . . .4-100



# Source Control BMPs

## Purpose of this Volume

This volume was designed to help businesses, homeowners and public agencies in Tacoma implement source control best management practices (BMPs) to prevent pollutants from contaminating stormwater runoff and entering our rivers, lakes, and streams.

## Content and Organization of this Volume

Volume 4 contains five chapters and four appendices.

- Chapter 1 provides an overview of who should use this volume and the type of pollutants being targeted.
- Chapter 2 provides a worksheet for commercial and industrial activity.
- Chapter 3 provides BMPs for single-family residences.
- Chapter 4 provides BMPs for commercial and industrial activities.
- Appendix A provides a list of phone numbers for related agencies.
- Appendix B lists recommended management procedures for the handling of hazardous wastes.
- Appendix C provides an example of an Integrated Pest Management program.
- Appendix D provides recommendations for the management of street wastes.

**This Page Intentionally Left Blank**

# Chapter 1 Frequently Asked Questions

## 1.1 Applicability

The implementation of BMPs applies to all businesses, residences and public agencies in Tacoma.

## 1.2 Pollutants of Concern

The City is required to show progress in eliminating virtually all non-stormwater discharges to the storm drainage system. Only uncontaminated stormwater may be discharged to the City of Tacoma storm drainage system. Illicit discharges, intentional or unintentional, are not allowed and polluters may be subject to state and federal penalties. It is the property owner's responsibility to keep pollutants from leaving a property and entering the City storm drainage system.

Pollutants can be placed into several broad categories, as listed below.

### 1.2.1 pH

The pH value of a substance is a relative measure of whether it is acidic or basic. Most aquatic species can only survive in neutral conditions. Sources that can contribute to a change in pH of stormwater and waterbodies include cement in concrete pouring, paving, and recycling operations; solutions from metal plating; chemicals from printing businesses and other industrial processes; and household cleaners such as bleaches and deck washes.

### 1.2.2 Total Suspended Solids

This represents particulate solids such as eroded soil, heavy metal precipitates, and biological solids which can cause sedimentation in streams and turbidity in receiving surface waters. Sediments can destroy the desired habitat for fish and can impact drinking water supplies. Sediment may be carried to streams, lakes, or Puget Sound where they may be toxic to aquatic life and destroy habitat.

### 1.2.3 Oils and Greases

Oils and greases can be either petroleum-based or food-related sources. Petroleum-based compounds can be immediately toxic to fish and wildlife, and can destroy our drinking water aquifers. Food-based oils and greases can coat fish gills and insects, suffocating them. Oils and greases can clog conveyance systems, which may cause flooding.

### 1.2.4 Oxygen-demanding Substances

Degradable organic matter, such as yard, food, and pet wastes, and some chemical wastes, can have a drastic effect on water quality. These substances, when broken down by bacteria, consume the oxygen in the water. This stresses and can eventually kill fish and other creatures in the water.



### **1.2.5 Metals**

Metals are utilized in many products important to our daily lives. Certain metals, known as heavy metals, wear off of our car brakes and tires, and come from the paint and moss-killing roof strips and herbicides we use at our homes. These metals can cause severe health and reproductive problems in fish and animals that live in water. Metals can be transported on sediments to waterbodies.

### **1.2.6 Bacteria and Viruses**

Bacteria and viruses from pet wastes, failing septic systems and agricultural areas can contaminate drinking water and close down swimming and shellfish areas. A group of bacteria called fecal coliform bacteria are typically used as the indicators for all bacteria and viruses, so large amounts of fecal coliform may indicate serious problems.

### **1.2.7 Nutrients**

In the context of water quality, nutrients are mainly compounds of nitrogen and phosphorus. When nutrients are allowed to enter waterbodies, undesirable effects such as algae overgrowth, oxygen depletion, channel clogging due to overgrowth of vegetation, and fish and animal death can occur. Sources of nutrients can include fertilizers, failing septic systems, and yard and animal wastes.

### **1.2.8 Toxic Organic Compounds**

A number of organic chemicals are just plain toxic when they get into the aquatic environment. Pesticides, herbicides, rodenticides, and fungicides are deadly to aquatic life. Compounds such as antifreeze, wood preservatives, cleansers, and a host of other, more exotic organics derived from industries or past practices (such as polychlorinated biphenyls (PCBs), DDT, and chlordane) can also have detrimental effects on the environment.

### **1.2.9 Other Chemicals and Substances**

There are a host of other chemicals that can cause problems if allowed to enter the aquatic environment. Common household bleach can be deadly to fish and other critters if drained directly to waterbodies. Diatomaceous earth backwash from swimming pool filters can clog gills and suffocate fish. Arsenic has been used in rat and mole killing compounds. Even those compounds classified as biodegradable or environmentally friendly can have immediate devastating effects on aquatic life.

## **1.3 Types of Source Control BMPs**

As the name implies, source control BMPs prevent contamination from entering stormwater runoff by controlling them at the source. There are two categories of source control BMPs:

- Operational BMPs
- Structural BMPs

### **1.3.1 Operational BMPs**

Operational source control BMPs are considered to be the most cost effective pollutant minimization practices. Operational source control BMPs are non-structural practices that prevent or reduce pollutants from entering stormwater. They can also include process changes such as raw material/product changes and recycling wastes.

Examples include:

- Formation of a pollution prevention team
- Good housekeeping practices
- Preventive maintenance procedures
- Spill prevention and cleanup
- Employee training
- Inspections of pollutant sources
- Record keeping

### **1.3.2 Structural BMPs**

Structural source control BMPs are physical, structural or mechanical devices or facilities that are intended to prevent pollutants from entering stormwater.

Examples of structural source control BMPs typically include:

- Enclosing and/or covering the pollutant source, i.e., within a building or other enclosure, a roof over storage and working areas, a temporary tarp
- Physically segregating the pollutant source to prevent run-on of uncontaminated stormwater
- Devices that direct only contaminated stormwater to appropriate treatment BMPs, i.e. discharge to a sanitary sewer if allowed by the local sewer utility.

**This Page Intentionally Left Blank**

## Chapter 2 Worksheet for Commercial and Industrial Activities

This worksheet is designed for use by business and industry operators. Complete the entire worksheet by checking the appropriate boxes for all activities that take place at the work site. If any of the activities as being performed outdoors, use the activity code on the worksheet to find the recommended BMPs contained in Chapter 4 .

Activity Code (BMP)	Type of Activity	Are you involved in this? If so, check if it occurs:	
		Indoors <sup>a</sup>	Outdoors <sup>b</sup>
<b>BMP W100 - CLEANING AND WASHING ACTIVITIES</b>			
W100	Covers cleaning and washing of tools, engine parts, cooking equipment, fleet vehicles yards, car dealerships, carpet cleaners, etc.		
<b>SECTION A2 - TRANSFERS OF LIQUID OR SOLID MATERIALS</b>			
A201	Loading and Unloading Areas for Liquid or Solid Material – for loading and unloading of materials at industrial and commercial facilities.		
A202	Fueling at Dedicated Stations – includes gas stations, pumps at fleet vehicle yards or shops, and other privately owned pumps.		
A203	Vehicle Maintenance Activities – covers oil changes and other engine fluids.		
A204	Mobile Fueling of Vehicles and Heavy Equipment – includes fleet fueling, wet fueling, and wet hosing.		
<b>SECTION A3 - PRODUCTION AND APPLICATION ACTIVITIES</b>			
A301	Concrete and Asphalt Mixing and Production at Stationary Sites – applies to mixing of raw materials on-site to produce concrete or asphalt.		
A302	Concrete Pouring, Concrete Cutting, and Asphalt Application at Temporary Sites – includes construction sites, and driveway and parking lot resurfacing.		
A303	Manufacturing and Post-processing of Metal Products – includes machining, grinding, soldering, cutting, welding, quenching, rinsing, etc.		
A304	Wood Treatment Areas – includes wood treatment using pressure processes or by dipping or spraying.		
A305	Commercial Composting – includes commercial composting facilities operating outside.		
A306	Landscaping and Lawn/Vegetation Maintenance, Including Vegetation Removal, Herbicide and Insecticide Application, Fertilizer Application, Irrigation, Watering, Gardening, and Lawn Care – includes businesses involved in landscaping, applying pesticides and managing vegetation.		
A307	Painting, Finishing, and Coating of Vehicles, Boats, Buildings, and Equipment – includes surface preparation and the applications of paints, finishes, and/or coatings.		
A308	Commercial Printing Operations – includes materials used in the printing process.		

Activity Code (BMP)	Type of Activity	Are you involved in this? If so, check if it occurs:	
		Indoors <sup>a</sup>	Outdoors <sup>b</sup>
A309	Manufacturing Activities (Outside) - includes outdoor manufacturing areas.		
<b>SECTION A4 - STORAGE ACTIVITIES</b>			
A401	Storage or Transfer (Outside) of Solid Raw Materials, By-products, or Finished Products.		
A402	Storage and Treatment of Contaminated Soils – applies to contaminated soils that are excavated and left on-site.		
A403	Temporary Storage or Processing of Fruits or Vegetables – includes processing activities at wineries, fresh and frozen juice makers, and other food and beverage processing operations.		
A404	Storage of Solid Wastes and Food Wastes – includes regular garbage and all other discarded non-liquid items.		
A405	Farmer’s Markets		
A406	Recyclers and Scrap Yards – includes scrapped equipment, vehicles, empty metal drums, and assorted recyclables.		
A407	Treatment, Storage, or Disposal of Dangerous Wastes – Refer to Ecology and the Tacoma-Pierce County Health Department for more information.		
A408	Storage of Liquid, Food Waste, or Dangerous Waste Containers – includes containers located outside a building and used for temporary storage.		
A409	Storage of Liquids in Permanent Above-ground Tanks – includes all liquids in above-ground tanks.		
A410	Parking and Storage for Vehicles and Equipment – includes public and commercial parking lots.		
<b>SECTION A5 - CONSTRUCTION ACTIVITIES</b>			
A501	Clearing, Grading, and Preparation of Construction Sites – applies to land developing activities and to residential yard clearing and grading projects.		
A502	Demolition of Buildings – applies to removal of existing buildings and subsequent clearing of the rubble.		
A503	Building Repair, Remodeling, and Construction – applies to construction of buildings, general exterior building repair work and remodeling of buildings.		
<b>SECTION A6 - DUST CONTROL AND SOIL AND SEDIMENT CONTROL</b>			
A601	Dust Control at Disturbed Land Areas and Unpaved Roadways and Parking Lots.		
A602	Dust Control at Manufacturing Sites – includes grain dust, sawdust, coal, gravel, crushed rock, cement, and boiler fly ash.		
A603	Soil Erosion and Sediment Control at Industrial Sites – includes industrial activities that take place on soil.		
<b>SECTION A7 - OTHER ACTIVITIES</b>			
A701	Commercial Animal Handling Areas – includes kennels, fenced pens, veterinarians, and businesses that board animals.		

Activity Code (BMP)	Type of Activity	Are you involved in this? If so, check if it occurs:	
		Indoors <sup>a</sup>	Outdoors <sup>b</sup>
A702	Log Sorting and Handling – applies to log yards typically located at sawmills, ports, and pulp mills.		
A703	Boat building, Mooring, Maintenance, and Repair – includes all types of maintenance, repair, and building operations.		
A704	Logging – applies to logging activities that fall under Class IV general forest practices.		
A705	Mining and Quarrying of Sand, Gravel, Minerals, Peat, Clay, Rock, and Other Materials – does not include excavation at construction sites.		
A706	Swimming Pool and Spa Cleaning and Maintenance – includes every swimming pool and spa not at a single family residence. Commercial pool cleaners are included here for all pools.		
A707	Deicing and Anti-icing Operations for Airports and Streets - includes aircraft, runways/taxiways, streets and highways.		
A708	Roof and Building Drains at Manufacturing and Commercial Buildings – These sites will be referred to the Puget Sound Clean Air Agency.		
A709	Urban Streets – includes recommended BMPs.		
A710	Railroad Yards		
A711	Maintenance of Utility Vaults – includes public and private utility maintenance activities.		
A712	Maintenance of Roadside Ditches and Culverts		
A713	Spills of Oil and Hazardous Substances		
A714	Water Reservoir, Transmission Mainline, Wellhead, and Hydrant Flushing Activities		
<b>SECTION S1 - SOURCE CONTROL BMPs</b>			
S101	Eliminate Illicit Sewer to Storm Drainage System Connections		
S102	Dispose of Contaminated Stormwater and Waste Materials Properly		
S103	Discharge Process Wastewater to a Sanitary Sewer, Holding Tank, or Water Treatment System		
S104	Cover the Activity with a Roof or Awning		
S105	Cover the Activity with an Anchored Tarp or Plastic Sheet		
S106	Pave the Activity Area and Slope to a Sump or Holding Tank, or Oil/Water Separator		
S107	Surround the Activity Area with a Curb, Dike, or Berm or Elevate the Activity		
S108	Implement Integrated Pest Management Measures		
S109	Cleaning Catch Basins		

a. If any of these activities occur indoors, then BMPs are not required, provided no indoor drains or processes can ultimately contact stormwater or be transported to surface waters such as rivers, lakes and streams. Ensure that liquids, powders, dusts and fine granular materials stay confined indoors. Otherwise BMPs will be required.

b. If any of these activities occur outdoors, then use the activity code to find the appropriate BMPs described in Chapter 4.

**This Page Intentionally Left Blank**

## Chapter 3 BMPs for Homeowners

Actions taken each day in and around homes have a profound effect on surface water quality and fish habitat in this region. Stormwater goes directly to lakes, streams and to Puget Sound. Stormwater does not go to the wastewater treatment plant. Any pollutants that get into the stormwater go directly to surface water. Small amounts of pollution from many different sources can significantly affect our waterways. Yard maintenance, waste storage, car washing and maintenance, and pool cleaning are some of the activities that can adversely impact water quality. The best management practices (BMPs) discussed in this section are practical ways to keep stormwater from becoming polluted in the first place. It is recommended that all residents in Tacoma use these BMPs. Please note that some of these procedures are required by various state, or city laws, and are noted as required BMPs.

A general list of best management practices (BMPs) for homeowners is described in this chapter. Some of the BMPs described in Chapter 4 may also be applicable to homeowners.

- Section 3.1 – Automobile Washing
- Section 3.2 – Automobile Maintenance
- Section 3.3 – Storage of Solid Wastes and Food Wastes
- Section 3.4 – Composting
- Section 3.5 – Yard Maintenance and Gardening
- Section 3.6 – Swimming Pool and Spa Cleaning and Maintenance
- Section 3.7 – Household Hazardous Material Use, Storage, and Disposal
- Section 3.8 – General Home Maintenance

### 3.1 Automobile Washing (for Single-Family Residences)

Car washing at home will cause washwater to enter the storm system and flow untreated into surface waters. Soaps and detergents, even the biodegradable ones, can have immediate and long-term effects. Washwater from car washing could be considered an illicit discharge and is prohibited from entering the stormwater system per Tacoma Municipal Code and state requirements.

#### 3.1.1 Required BMPs

Engine degreasing or washing of internal engine components is not permitted at home. Take car to a commercial car wash that allows engine washing.

#### 3.1.2 Suggested BMPs

The best option is to take cars to a commercial car wash that has a recycle system and discharges wastewater to the sanitary system for treatment. If this option is not feasible, use the suggested BMPs below.

##### 3.1.2.1 At Home:

- Wash cars directly over lawn areas or make sure the wash water drains to a vegetated area.
- Ideally, no soaps or detergents should be used, but if one is used, select one without phosphates.



- Consider using commercial products that allow cleaning a vehicle without water.
- Use a hose nozzle with a shut-off valve to save water.
- Do not wash cars if rain is expected.
- Pour the bucket of soapy, dirty washwater down your sink.

### **3.1.2.2 Away from Home:**

- Go to fundraising car washes where sponsors use Tacoma's Clean Bay Car Wash loaner kits. Look for the Clean Bay Car Wash logo. Use a Clean Bay Car Wash loaner kit. If your group is planning a car wash in Tacoma, call 253-502-2220 or refer to the City of Tacoma website to reserve a Clean Bay Car Wash loaner kit.

## **3.2 Automobile Maintenance**

### **3.2.1 Required BMPs**

- Recycle all oils, antifreeze, solvents, and batteries. Many local car parts dealers and gas stations accept used oil. The Household Hazardous Waste facility at the Tacoma Landfill accepts oil, oil filters, antifreeze, and solvents. Old batteries can actually be worth money. Recycle old batteries at battery shops or the Tacoma Landfill.
- Never dump new or used automotive fluids or solvents on the ground, in a storm drain or street gutter, or in a waterbody.
- Do not mix wastes. Always keep your wastes in separate containers which are properly labeled and store them under cover.
- Household Hazardous Waste cannot be disposed of with regular garbage. Contact the City of Tacoma Household Hazardous Waste Facility at 253.591.5418 or go to [www.cityoftacoma.org/solidwaste](http://www.cityoftacoma.org/solidwaste) for additional information.

### **3.2.2 Suggested BMPs**

- Fix all leaks to ensure materials stay off the streets and out of the stormwater system and local waterways.
- To dispose of oil filters:
  - Punch a hole in the top and let drain into a plastic container for at least 24 hours.
  - Once the filter is drained, wrap the filter in 2 layers of plastic and dispose of it in your regular garbage. The used motor oil may not be disposed of with household garbage.OR
  - Recycle the used oil filter by taking it to the Tacoma Landfill, Household Hazardous Waste facility.

**NOTE:** The used oil shall be recycled at an approved facility and cannot be disposed of with your regular garbage.
- Use care in draining and collecting antifreeze to prevent accidental spills. Spilled antifreeze can be deadly to cats and dogs that ingest it.
- A tarp, ground cloth, sheet of cardboard, drip pans, or other materials to contain drips must be used beneath the vehicle or equipment to capture all spills and drips. Keep a bag of kitty litter on hand to absorb any spills. Sprinkle a layer on the spill, let it absorb and

sweep it up. Dispose of the contaminated litter in the regular garbage in a tied plastic bag. Do not leave kitty litter out in the rain.

- If body work is performed outside, be sure to use a tarp to catch material resulting from grinding, sanding, and painting. Dispose of this waste by double bagging in plastic and placing in garbage.

### **3.3 Storage of Solid Wastes and Food Wastes**

Improper storage of food and solid waste at residences can lead not only to water pollution problems, but problems with neighborhood pets and vermin as well.

#### **3.3.1 Required BMPs**

- City of Tacoma residents shall use the City of Tacoma Solid Waste Management waste containers. These containers should have lids. If the lid is damaged, please call Tacoma Solid Waste Management at 253-591-5543 to get the lid repaired or replaced.
- Leaking waste containers should be replaced. If the container is damaged, please call Tacoma Solid Waste Management at 253-591-5543.

#### **3.3.2 Suggested BMPs**

- Store waste containers under cover if possible, or on grassy areas.
- Use the Tacoma Call-2-Haul program to pick up bulky materials and excess waste material. Call 253-573-2468 for more information and details, or to set up an appointment for waste pickup.
- Inspect the storage area regularly to pick up loose scraps of material and dispose of them properly.
- Recycle as much as you can. Tacoma offers curbside recycling. Also, look under "Recycling" in the phone book for firms which take other recyclables.
- Purchase products which have the least amount of packaging materials.
- Compost biodegradable materials such as grass clippings and vegetable scraps instead of throwing them away. Call Tacoma Solid Waste Utility Recycling and Composting at 253-565-5955 for more information on composting. See the section on Composting for BMPs relating to that activity.
- An alternative to traditional composting is worm composting. For more information on getting started with worm composting, call the number listed above.

### **3.4 Composting**

Composting is an earth-friendly activity as long as the rules outlined below are followed. The following BMPs are applicable to composting.

#### **3.4.1 Required BMPs**

- Locate compost piles on an unpaved area that is not subject to stormwater runoff or runoff; that is not prone to water ponding during storms; and well away from wetlands, streams, lakes and other drainage ways.

### **3.4.2 Suggested BMPs**

- Compost piles must be maintained and turned over regularly to work properly. Large piles of unattended compost may create odor and vermin problems.
- Do not put hazardous or non-decomposable waste in the pile.
- Cover the compost pile for two reasons:
  - To keep stormwater from washing nutrients into waterways.
  - To keep excess water from cooling down the pile, which will slow down the rate of decomposition.
- Build bins of wood, chicken wire, or fencing material to contain compost so it can't be washed away. Call Tacoma Solid Waste Utility Recycling and Composting at 253-565-5955 to get free composter designs and materials lists.
- Building a small earthen dike around a compost pile is an effective means of preventing nutrient-rich compost drainage from reaching stormwater paths.

## **3.5 Yard Maintenance and Gardening**

This section deals with the normal yard maintenance activities typically performed at residences. Overwatering, overfertilizing, improper herbicide application, and improper disposal of trimmings and clippings can all contribute to serious water pollution problems. Following the BMPs listed below will help alleviate pollutant runoff.

### **3.5.1 Required BMPs**

- Follow the manufacturer's directions exactly for mixing and applying herbicides, fungicides, and pesticides, and use them sparingly. Never apply when it is windy or when rain is expected. Never apply over water, within 100 feet of a well-head, or adjacent to streams, wetlands, or other waterbodies. Triple-rinse empty containers, using the rinsate for mixing your next batch of spray, and then double-bag and dispose of the empty container in your regular garbage.
- Never dispose of grass clippings or other vegetation in or near storm drains, streams, lakes, or Puget Sound.
- Make sure all fertilizers and pesticides are stored in a covered location.

### **3.5.2 Suggested BMPs**

- Use natural, organic soil amendments like Tacoma's TAGRO Mix. TAGRO Mix is a 100% recycled blend of de-watered, Class A, "Exceptional Quality" biosolids, mixed with sawdust and sand.
- Use an integrated pest management program (IPM), which is a natural, long-term, ecologically based approach to controlling pest populations. See Section 4.4.6 and Appendix C – Example of an Integrated Best Management Program.
- Save water and prevent pollution problems by watering lawns sensibly. Lawns and gardens typically need the equivalent of 1-inch of rainfall per week. Put a wide mouth jar out where watering is occurring, and measure the water with a small plastic ruler. Overwatering to the point of runoff can carry polluting nutrients to the nearest waterbody.
- Consider planting a vegetated buffer zone adjacent to streams or other water bodies. Call the Pierce County Conservation District at 253-845-2973 for advice and assistance in developing a planting plan.

- Reduce the need for pesticides and fertilizers on lawns by improving the health of the soil. Aerating, thatching, and topdressing with compost will improve soil health and help wanted grasses compete with weeds and moss.
- Use a mulching mower and mow higher to improve soil/grass health and reduce or eliminate pesticide use.
- Compost all yard clippings, or use them as mulch to save water and keep down weeds in your garden. See Section 3.4 for more information.
- Practice organic gardening and virtually eliminate the need to use pesticides and fertilizers. Contact Pierce County Cooperative Extension at 253-591-7180 or the Ask-A-Master Gardener program at 253-591-7170 for information and classes on earth-friendly gardening.
- Pull weeds instead of spraying. If you must spray, use the least toxic formulations that will get the job done. The Master Gardener program listed above can help advise you on which spray to use.
- Work fertilizers into the soil instead of letting them lie on the ground surface exposed to the next rain storm.
- Plant vegetation suited to Northwest conditions because they require less water and fewer to no fertilizers and pesticides.
- Tacoma has a curbside yard waste recycling program. Call 253-565-5955 for more information.
- Plant growing trees. For more information on growing trees visit [www.cityoftacoma.org/urbanforestry](http://www.cityoftacoma.org/urbanforestry). Properly prune all trees.

### **3.6 Swimming Pool and Spa Cleaning and Maintenance**

The water from pools and spas is far from chemically clean. Nutrients, pH, and chlorine can adversely affect fish and wildlife in waterbodies. Following these BMPs will ensure the cleanliness of your pool and the environment.

#### **3.6.1 Required BMPs**

- Pool and spa water must be dechlorinated if it is to be emptied into a ditch, on the ground or a lawn, or to the storm drainage system. The discharges shall be dechlorinated to a concentration of 0.1 ppm or less, pH-adjusted and reoxygenated if necessary, and volumetrically and velocity controlled to prevent resuspension of sediments in the stormwater system. Contact a pool chemical supplier to obtain the neutralizing chemicals needed. The rate of flow into the ditch or drainage system must be regulated so that it does not cause problems such as erosion, surcharging, or flooding. Water discharged to the ground or a lawn must not cross property lines and must not produce runoff.
- Swimming pool cleaning wastewater and filter backwash shall not be discharged to the MS4.
- If pool and spa water cannot be dechlorinated, it must be discharged to the sanitary sewer. Prior to draining a pool or spa, notify the local wastewater treatment plant to ensure they are aware of the volume of discharge and the potential effects of chlorine levels. A pool service company can help determine the frequency of cleaning and backwash of filters.

- Diatomaceous earth used in pool filters cannot be disposed of in surface waters, on the ground, or into storm drainage systems or septic systems. Dry it out as much as possible, bag it in plastic, and dispose of at the landfill.

### **3.6.2 Suggested BMPs**

- Hire a professional pool service company to collect all pool water for proper disposal. Make sure to ask where the water will be disposed of and ensure the proper permits have been obtained.

## **3.7 Household Hazardous Material Use, Storage, and Disposal**

Oil-based paints and stains, paint thinner, gasoline, charcoal starter fluid, cleaners, waxes, pesticides, fingernail polish remover, and wood preservatives are just a few hazardous materials typically used in a residential setting.

When hazardous materials are dumped on the ground or in a storm drain, they can be washed directly to receiving waters where fish and wildlife can be harmed. Hazardous materials can also infiltrate into the ground and contaminate drinking water supplies.

With such a diversity of hazardous products present in all homes in Tacoma, a large potential for serious environmental harm exists if improper methods of storage, usage, and disposal are employed. Using the following BMPs will help keep these materials out of soils, sediments, and waters.

### **3.7.1 Required BMPs**

- Hazardous materials must be stored out of the reach of children.
- Dispose of hazardous materials and their containers properly. Never dump products labeled as poisonous, corrosive, caustic, flammable, inflammable, volatile, explosive danger, warning, caution, or dangerous outdoors, in a storm drain, or into sinks, toilets, drains or septic systems. Call the Household Hazardous Waste Facility at 253-591-5418 or the Hazardous Waste Line at 1-800-287-6429 for information on disposal methods, collection events, and alternative products. Household hazardous wastes from City of Tacoma residents are accepted at the Tacoma Landfill.
- Store hazardous materials containers under cover and off the ground. Keep them out of the weather to avoid rusting, freezing, cracking, labels being washed off, etc.

### **3.7.2 Suggested BMPs**

- Check hazardous material containers frequently for signs of leakage. If a container is rusty and has the potential of leaking soon, place it in a secondary container before the leak occurs and prevent a clean-up problem.
- Keep appropriate spill cleanup materials on hand. Kitty litter is good for many oil-based spills.
- Ground cloths and drip pans must be used under any work outdoors which involves hazardous materials such as oil-based paints, stains, rust removers, masonry cleaners, and others bearing label warnings as outlined above.
- Latex paints are not a hazardous waste, but are not accepted in liquid form at the landfill. To dispose, leave uncovered in a protected place until dry, then place in the garbage. If you wish to dry waste paint quickly, just pour kitty litter in the can to absorb the paint.

Once paint is dry, leave the lid off when you place it in the garbage so the garbage collector can see that it is no longer liquid.

- Use less toxic products whenever possible. The Hazardous Waste Line at 1-800-287-6429 and the Washington Toxics Coalition at 206-632-1545 have information detailing alternatives to toxic products.
- If an activity involving the use of a hazardous material can be moved indoors out of the weather, then do so. Make sure proper ventilation is provided.
- Follow manufacturers' directions in the use of all materials. Over-application of yard chemicals, for instance, can result in the washing of these compounds into receiving waterbodies. Never apply pesticides when rain is expected.
- When hazardous materials are in use, place the container inside a tub or bucket to minimize spills.
- Purchase only the amount of product that's needed.

### **3.8 General Home Maintenance**

This section deals with the normal maintenance activities typically performed in residential settings. Following the BMPs listed below will help alleviate pollutant runoff.

#### **3.8.1 Required BMPs**

- Pressure washing of building facades, rooftops, pavement, and other large objects must be conducted in such a way that all of the runoff is collected for proper disposal. No runoff shall leave the site. Temporary curbs, dikes, or berms may be used to direct the water away from storm drains. Water should be directed to the sanitary system or directed to an area where it can evaporate. Debris generated from pressure washing must be swept and disposed as solid waste.

#### **3.8.2 Suggested BMPs**

- Carpet cleaning wash water must be disposed of to the sanitary sewer. It is preferred that the dirty wash water be discharged into a toilet or mop sink at the place where it was generated.
- Clean brushes and tools coated with non-water-based paints, finishes, or other materials in a manner that allow collection of used solvents (e.g. paint thinner, turpentine, xylol, etc.) for proper disposal at a Household Hazardous Waste Facility. Call the Household Hazardous Waste Facility at 253-591-5418 or the Hazardous Waste Line at 1-800-287-6429 for information on disposal methods, collection events, and alternative products. Household hazardous wastes from City of Tacoma residents are accepted at the Tacoma Landfill.

## 3.9 Pet Waste

Pets can generate pollutants from pet waste, animal washing, and cage or kennel cleaning. Pollutants include bacteria which can pollute water ways and make people sick. To prevent pet waste pollutants from entering the storm drains, follow the BMPs listed below.

### 3.9.1 Required BMPs

- Regularly scoop, sweep and clean up pet waste deposited on walks and at home. Dispose of pet waste in the garbage or flush it down the toilet. Kitty litter shall not be flushed down a toilet. Dispose of it with garbage.
- When cleaning out cages and kennels, wash directly over lawn areas or make sure the wash water drains to a vegetated area. Alternately, dispose of the wash water down the toilet or a mop sink.
- Do not dispose of unused pet pharmaceuticals in a storm drain, flush down a toilet, or wash down a sink. Visit [www.takebackyourmeds.com](http://www.takebackyourmeds.com) for a list of locations that take back unused pharmaceuticals.
- Refer to BMP A701: Commercial Animal Handling Areas for kennels, boarding areas, veterinarians, etc.

## Chapter 4 BMPs for Commercial and Industrial Activities

This chapter coordinates with the worksheet completed in Chapter 2. That worksheet and the BMPs are organized by the different activities that businesses perform. If the listed activity is performed indoors and all discharges from the activity are controlled (e.g., process water, wash water, lubricants, solvents, fugitive dust, granular material, blowdown waste, etc.) such that no exposure to stormwater occurs, then no new BMPs for that activity are required. However, if the column for activities performed outdoors was checked, match the number from the worksheet to the activities listed in this section to find the BMPs suggested.

Contact the City of Tacoma Source Control Unit at 253-591-5588 for more information or technical assistance. Assistance can be provided over the phone or at on-site consultations.

**Every person/business in Tacoma is required to use BMPs as outlined in this manual.** Utilizing additional BMPs to further protect water quality is encouraged.

Some businesses are or will be required to obtain a National Pollutant Discharge Elimination System (NPDES) permit for stormwater discharges. These permits are issued and regulated by the Washington State Department of Ecology.

There are several BMPs contained in this chapter that may also apply to residences and other non-commercial or non-industrial sites.

### 4.1 BMPs for All Activities

#### 4.1.1 Mandatory Operational BMPs

The following operational BMPs are required at:

- Commercial properties
- Industrial properties
- Multifamily properties
- Boatyards
- Sand and gravel mining operations

Many of the following practices may also be included in the activity specific individual BMPs.

- Assign one or more individuals to be responsible for stormwater pollution control. Hold regular meetings to review the overall operation of the BMPs. Establish responsibilities for inspections, operation, maintenance, and for emergencies. Train all team members in the operation, maintenance, and inspections of BMPs, and reporting procedures.
- Promptly contain and clean up solid and liquid pollutant leaks and spills. Use solid absorbents for cleanup of liquid spills, where practicable. Do not flush or otherwise direct absorbent materials or other spill cleanup materials to a storm drain. Collect the contaminated absorbent material as a solid and place in appropriate disposal containers.
- Sweep all appropriate surfaces with vacuum sweepers quarterly or more frequently as needed for the collection and disposal of dust and debris that could contaminate stormwater.
- Do not hose down pollutants from any area to the ground, storm drains, conveyance ditches, or receiving water unless necessary for dust control purposes to meet air quality regulations.



- Clean oils, debris, sludge, etc. from all stormwater facilities regularly to prevent the contamination of stormwater. Refer to Appendix B for references to assist in handling potentially dangerous waste.
- Promptly repair/replace/reseal all substantially cracked or otherwise damaged paved secondary containment, high-intensity parking areas, and any other drainage areas that may be subjected to pollutant material leaks or spills.
- Promptly repair or replace all leaking connections, pipes, hoses, valves, etc., which can contaminate stormwater.
- Do not connect floor drains in potential pollutant source areas to storm drains, surface water, or to the ground. Floor drains shall be connected to the wastewater system.

#### **4.1.2 Mandatory Good Housekeeping BMPs**

- Recycle materials, such as oils, solvents, and wood waste, to the maximum extent practicable.
- Do not pave over contaminated soil unless it has been determined that groundwater has not been and will not be contaminated by the soil.
- Construct impervious areas that are compatible with the materials handled.
- Use drip pans to collect leaks and spills from industrial/ commercial equipment. Empty drip pans immediately after a spill or leak is collected in an uncovered area.
- Where exposed to stormwater, use containers, piping, tubing, pumps, fittings, and valves that are appropriate for their intended use and for the contained liquid

#### **4.1.3 Mandatory Preventive Maintenance BMPs:**

- Minimize use of toxic cleaning solvents, such as chlorinated solvents, and other toxic chemicals.
- Use environmentally safe raw materials, products, additives, etc. such as substitutes for zinc used in rubber production.
- Stop, contain, and cleanup all spills immediately upon discovery.

#### **4.1.4 Additional Recommended BMPs:**

- Maintain records of all related pollutant control and pollutant generating activities such as training, materials purchased, material use and disposal, maintenance performed, etc.

## 4.2 BMP W100: Washing Best Management Practices

**Applicability:** These BMPs encompass washing practices related to various commercial washing activities. Typically, all washwater must be discharged to the sanitary sewer system, collected for off-site disposal, or recycled. Some washing practices may discharge their washwater into nearby landscaped areas or into the stormwater system with proper pretreatment. Table 4 - 1 shows the allowable discharge location for various washing activities. Following the table are required and recommended BMPs for specific washing activities. Below are the required and recommended BMPs that apply to all washing practices.

BMPs for homeowners can be found in Chapter 3.

### Required BMPs for all washing activities:

- Follow Table 4 - 1 to determine the required discharge location based upon washing activity.
- Illicit connections to the storm drainage system must be eliminated. See BMP S101 for detailed information.
- Employees must be educated to control washing operations to prevent stormwater contamination.
- Follow the Environmental Services Source Control Oil Water Separator Policy for Discharges to Sanitary Sewer as appropriate. The policy is available at [www.cityoftacoma.org/stormwater](http://www.cityoftacoma.org/stormwater).
- For facilities with a dedicated wash pad, at a minimum the pad must be equipped with a catch basin/sediment trap that discharges through a tee outlet to the sanitary sewer. Discharges to the sanitary sewer system must meet the discharge limits of TMC 12.08 before discharge is allowed. Sampling, testing, and pretreatment of the wastewater may be required to meet limits.
- If any washing of vehicle or equipment that contains oils is to be conducted on the wash pad an oil/water separator will be required. See the Environmental Services Oil Water Separator Policy for Discharges to the Sanitary Sewer at [www.cityoftacoma.org/stormwater](http://www.cityoftacoma.org/stormwater) for additional guidance.
- Contact City of Tacoma Source Control at 253-591-5588 for assistance.

### Recommended BMPs for all washing activities:

- Limit the amount of water used in washing activities.
- Recycle washwater when possible for subsequent washings.
- If soaps and detergents are used, use the least toxic cleaner capable of doing the job. Select non-phosphate detergents when possible.
- Cover and/or contain the cleaning activity inside a building to separate uncontaminated stormwater from the pollutant sources.

**Table 4 - 1: Discharge Options for Businesses<sup>a</sup>**

Item to be Washed	Sanitary Sewer <sup>b</sup>	Collect/Closed-Loop Recycle/Haul	Landscape/Soil <sup>c</sup> No Soaps or Chemicals	Storm Drain No Soaps or Chemicals
<b>Tools, Rental &amp; Construction Equipment, &amp; Machinery</b>	OK	OK	Not Allowed	Not Allowed
Backhoes	OK	OK	Note 2	Not Allowed
Lawn mowers	OK	OK	Note 2	Not Allowed
Cooling towers	OK	OK	Not Allowed	Not Allowed
<b>Cooking Equipment</b>				
Mats	OK	OK	Not Allowed	Not Allowed
Floors				
Exhaust fans & hoods				
<b>Buildings &amp; Structures</b>				
Exteriors/roofs				
Windows	OK	OK	Notes 2 & 3	Notes 2 & 3
HVAC systems				
Sidewalks				
Parking	OK	OK	Not Allowed	Not Allowed
<b>Interiors</b>				
Floor stripping	OK	OK	Not Allowed	Not Allowed
Carpets				
Windows				
<b>Vehicles<sup>d</sup></b>				
New/Used car lots	OK	OK	Notes 1 & 2	Note 2
Golf carts	OK	OK	Notes 1 & 2	Not Allowed
Import/Export equipment	OK	OK	Not Allowed	Not Allowed
Charity car washes	OK	OK	Notes 1 & 2	Not Allowed
RV, truck, auto detailing & engine washing	OK	OK	Not Allowed	Not Allowed
Mobile truck-fleet washers	OK	OK	Not Allowed	Not Allowed
Boats	OK	OK	Not Allowed	Not Allowed

a. These are guidelines only and not meant to be all-inclusive. The City of Tacoma reserves the right to diverge from this, depending upon site-specific conditions.

b. Discharge may require pretreatment per TMC Chapter 12.08.

c. Discharges to the ground may require permission from the Tacoma/Pierce County Health Department if the site is located within the South Tacoma Groundwater Protection District.

d. Specific Guidelines are available for automatic wand and mobile fleet washers. Contact City of Tacoma Source Control at 253-591-5588.

**Note 1:** Meet requirements of WDOE publication WQR 95-56 *Vehicle and Equipment Washwater Discharges*. Solids must be collected and no visible sheen is allowed.

**Note 2:** Cold water only. No detergents or other cleaners may be used.

**Note 3:** No pollutants after pretreatment. Work area must be pre-scraped and/or pre-swept. Please refer to Volume 2, Section 3.2, [Standards and Specifications for Best Management Practices \(BMPs\)](#) for pretreatment BMPs.

#### **4.2.1 Cleaning or Washing of Tools, Equipment, and Machinery**

**Applicability:** This activity applies to businesses and public agencies that clean manufacturing equipment such as saws, grinders, screens, and other processing devices outside of buildings, and to businesses engaged in pressure washing of engines, equipment, and portable objects.

Pollutant sources include toxic hydrocarbons, organic compounds, oils and greases, nutrients, heavy metals, pH, suspended solids, biochemical oxygen demand (BOD), and chemical oxygen demand (COD).

**Required BMPs** for cleaning or washing of tools, machinery, equipment, and portable objects:

- All washwater shall either:
  - Be discharged to the sanitary sewer,
  - Be temporarily stored before proper disposal, or
  - Be recycled.

See BMP S103: Discharge Process Wastewater to a Sanitary Sewer, Holding Tank, or Water Treatment System for additional information.

- Pressure washing must be conducted in a designated area (such as a permanent or temporary wash pad) provided with some means of capturing the washwater, and stormwater run-on prevention. Permanent wash pads must drain to the sanitary sewer system through an approved pretreatment device. See BMP S106 and S107 for information on sumps (or holding tanks) and run-on prevention

#### **4.2.2 Cleaning or Washing of Cooking Equipment**

**Applicability:** This activity applies to businesses that clean cooking equipment such as grills, vent filters, exhaust hoods, grease traps, floors and floor mats. Washing the outside of buildings, sidewalks, and paved areas is covered in the Building Structures and Related Equipment section below.

Pollutants of concern consist of pH, oil and grease, nutrients, suspended solids, and biochemical oxygen demand (BOD).

**Required BMPs** for cleaning or washing of cooking equipment:

- Cleaning and washing of cooking equipment shall take place indoors with drainage to the sanitary sewer system, holding tank, or process treatment system or captured using a tub or similar device to contain all the washwater. The washwater shall be recycled or disposed into the sanitary sewer system, holding tank, or process treatment system. Provisions must be in place to neutralize the washwater rinsate prior to discharge to the sanitary sewer system.
- If washing cannot be accomplished indoors, the washing must take place on a pad or be isolated in a way that all washwater drains to the sanitary sewer, holding tank, or process treatment system.
- Washwater shall not be discharged to the storm drainage system.

- Washwater from cleaning roof-top equipment, such as exhaust fans, shall be captured and disposed to the sanitary sewer. Use of wet/dry vacuums, temporary berms or containers, such as plastic pools, are possible ways to capture this water.
- Paved washing areas must be swept daily to collect loose solid materials for proper disposal.
- Greasy buildup on cooking equipment must be removed and properly disposed prior to washing to reduce the amount of material that can potentially contaminate the washwater. Washing must either take place on a wash pad connected to the sanitary sewer, or the wastewater must be collected and disposed in the sanitary sewer.
- See BMP S103 for detailed drainage requirements and BMP S107 for methods of run-on prevention. If connecting a wash area to the sanitary sewer, permits must be obtained from the City of Tacoma by calling the Permit Counter at 253-591-5030.
- If a holding tank is used for storage of washwater, the contents must be pumped out before it is full and disposed properly in an approved manner.

**Recommended BMPs** for cleaning or washing of cooking equipment:

- Discharge greasy washwater to the building's grease interceptor if one is available.
- Install grease protection if none is available.
- If washing must take place outdoors, provide a cover over the designated wash area to keep rain from falling on dirty equipment and producing contaminated runoff.

### 4.2.3 Building Structures and Related Equipment

**Applicability:** This activity applies to the washing of buildings, roofs, cooling towers, structures, sidewalks, and parking lots with low or high pressure water. This also includes removing graffiti.

Pollutants generated include heavy metals, pH, suspended solids, grit, paint chips, and biochemical oxygen demand (BOD).

**Required BMPs** for washing building structures and related equipment:

**General:**

- Pressure washing of building facades, rooftops, pavement, and other large objects must be conducted in such a way that all of the runoff is collected for proper disposal.
- Washwater shall be discharged to the sanitary sewer system with appropriate pretreatment to remove solids. Sediment removal BMPs include those as described in Volume 2 and include measures such as check dams, sorbent booms, and catch basin inserts. Temporary curbs, dikes, or berms may be needed to direct the washwater to a single collection point. Wet/dry vacuums, run-dry sump pumps, or educators may be used to collect the water for proper disposal to the sanitary sewer system. Discharges to the sanitary sewer system may require obtaining a Special Approved Discharge (SAD) Permit. Contact City of Tacoma Source Control at 253-591-5588 for additional information on SAD permits.
- If runoff does not contain pollutants, following appropriate pretreatment, such as filtration or sedimentation, washwater may be allowed to be discharged to landscaping or the storm drainage system. This may require obtaining a Special Approved Discharge Permit. Contact the City of Tacoma Source Unit at 253-591-5588 for review and approval before commencing washing activities.

**Buildings:**

- Washwater from building washing shall be discharged to the sanitary sewer system with appropriate pretreatment to remove solids. Some ways of capturing the water can be by using tarps with berms, made by wrapping the tarp over pieces of lumber.
- If only cold water is used to remove dirt from a concrete or brick-sided building, this water may be allowed to fall onto a planted area or diverted to landscaping.

**Rooftop Equipment:**

- Washwater from cleaning rooftop equipment, such as exhaust fans and HVAC systems, shall be captured and disposed to the sanitary sewer. Wet/dry vacuums, temporary berms or containers may be used to capture this water.

**Parking Lots:**

- Wastewater generated from washing parking lots shall discharge to the sanitary sewer system. This water must have 50 mg/L or less of total petroleum hydrocarbons before it can be discharged to the sanitary sewer. This may require pretreatment.
- Alternatively, the water can be captured and hauled to a treatment, storage, and disposal facility for proper treatment and disposal.

**Sidewalks:**

- Sweep, shovel, or scrape up large debris and trash before washing.
- If soaps or other cleaning agents are used, the wastewater shall be captured and routed to the sanitary sewer if it meets the discharge requirements of Tacoma Municipal Code Chapter 12.08.
- If using only cold water, the water may be directed to landscaping or to the stormwater system with proper pretreatment. A sediment removal device shall be placed in the gutter line and the receiving catch basin before discharge. See Volume 2 for sediment removal BMPs.

**Graffiti:**

- Wastewater generated from graffiti removal shall be captured and discharged to the sanitary sewer system. Tarps and berms or wet/dry vacuums can be used to capture the washwater. This water must meet City of Tacoma limits per TMC 12.08 before discharge to the sanitary sewer.
- If removing graffiti with a cleaner only, apply sufficient cleaner to do the job. Small areas shall be wiped clean instead of using water for removal.

**4.2.4 Interior Washing Operations**

**Applicability:** This activity applies to businesses that wash floors, carpets, and other interior items on a mobile site-to-site basis. The washing process includes removing wax from floors and may use machines that spray a wash solution onto the carpet or upholstery and suck the dirty solution up into a portable tank with limited capacity.

Pollutants of concern consist of pH, nutrients, suspended solids, organic compounds (such as pesticides and chemicals used for flea and odor control), and biochemical oxygen demand (BOD).

**Required BMPs** for doing mobile interior wash activities:

- Wastewater shall be discharged to a sanitary sewer system at the site of collection. If sanitary sewer disposal is not available or not allowed where the wastewater was generated, the collected wastewater must be returned to the business site for proper treatment and disposal. Contact the local sewer authority for disposal regulations if the place of business is not located within the City of Tacoma.
- Absolutely no wastewater from mobile interior wash activities shall be disposed outdoors, or to a drain connected to the storm drainage system. This point must be made clear to all employees.
- Wastewater from mobile washing operations may be permitted for sanitary sewer disposal if it does not contain high concentrations of toxic materials. Some of the chemicals used for flea and odor control are listed by EPA as toxics. Contact City of Tacoma Source Control at 253-591-5588 if you intend to use and discharge these types of chemicals in your wastewater.
- Carpet cleaning washwater must be disposed to the sanitary sewer, preferably into a toilet or sink at the place where it was generated. Screen the wastewater to protect the customer's drain from plugging. Do not discharge this wastewater to a septic system.

**Recommended BMPs** for doing mobile interior wash activities:

- Limit the amount of water used in interior washing operations. This will save time, money, and effort for proper disposal.

#### **4.2.5 Washing, Pressure Washing and Steam Cleaning of Vehicles**

**Applicability:** This activity includes the washing of vehicles, aircraft, vessels/boats and grocery carts, by low or high pressure water or steam and includes hand washing, scrubbing, sanding, etc. This also includes "charity" car washes at gas stations, religious organizations, and commercial parking lots.

Pollutants of concern from cleaning activities include oil and grease, suspended solids, heavy metals, pH, soluble organics, soaps, and detergents.

**Required BMPs** for washing, pressure washing and steam cleaning vehicles:

**General:**

- Washwater shall be discharged to the sanitary sewer unless otherwise noted below.
- If heavy accumulations of solids are to be removed during washing, then appropriate pretreatment to capture those solids must be provided. Volume 2 contains temporary sediment removal BMPs that can be utilized to capture solids before discharging wastewater to the sanitary sewer system.
- Two-step (acid – alkaline) washing may be allowed at all facilities discharging to the sanitary sewer. Provisions must be in place to neutralize the washwater rinsate prior to discharge to the sanitary sewer system.
- See the City of Tacoma Source Control Policy on Discharges from Vehicle and other Washing Activities for additional information.
- Contact City of Tacoma Source Control at 253-591-5588 for more information.

***New and Used Car Dealer Lots:***

- If washing previously cleaned vehicles is accomplished using **only** cold water (no soaps or detergents used) and consists of washing only the outside of the motor vehicles, discharge to the stormwater system will be allowed and discharge to the sanitary system is prohibited.

- If soaps or detergents are to be used, washing must occur on a dedicated wash pad. Only washing of the outside of the vehicles is permitted unless additional pretreatment is provided

**Other Washing Events:**

- Identify types of washing events and their locations (such as the Tacoma Dome RV show, etc.) and evaluate options on a case-by-case basis according to the discharge criteria stated above.
- Charity car washes shall wash only the exterior of vehicles. If soap is used, the washwater must be captured and directed to the sanitary sewer. For information concerning the use of charity car wash kits, contact the City of Tacoma Community Relations EnviroChallenger staff at 253- 502-2220.

**Automatic and Manual Car Wash:**

- See the City of Tacoma Source Control Policy on Discharges from Vehicle and Other Washing Activities and Policy for Discharges to Sanitary Sewer for additional information.

**RV, Truck, Auto Detailing, and Engine Washing Facilities:**

- Wash on a dedicated pad. See the City of Tacoma Source Control Policy on Discharges from Vehicle and Other Washing Activities and Policy for Discharges to Sanitary Sewer for additional information.

**Boat Washing Facilities:**

- Wash on a dedicated pad. See the City of Tacoma Source Control Policy on Discharges from Vehicle and Other Washing Activities and Policy for Discharges to Sanitary Sewer for additional information.
- For cleaning activities while boats are in the water refer to the Washington State Department of Ecology publication 98-11, *Resource Manual for Pollution Prevention in Marinas*, available at: <http://www.ecy.wa.gov/biblio/9811.html>

**Mobile Vehicle Washers:** This section applies to mobile vehicle and grocery cart washers doing work in the City of Tacoma. Detailed requirements and procedures may be found in The City of Tacoma Source Control Interim Policy for Mobile Vehicle Washers.

- Mobile vehicle washers shall capture all the washwater generated and discharge it to the sanitary sewer system through an on-site cleanout if available. The use of temporary wash pads, catch basin inserts, and vacuum systems are some possible means to capture the washwater. Other requirements may apply depending upon the items to be washed. Only wastewater generated within the City of Tacoma may be discharged into its municipal sewer system.



## 4.3 Transfer of Liquid or Solid Materials

### 4.3.1 BMP A201: Loading and Unloading Areas for Liquid or Solid Material

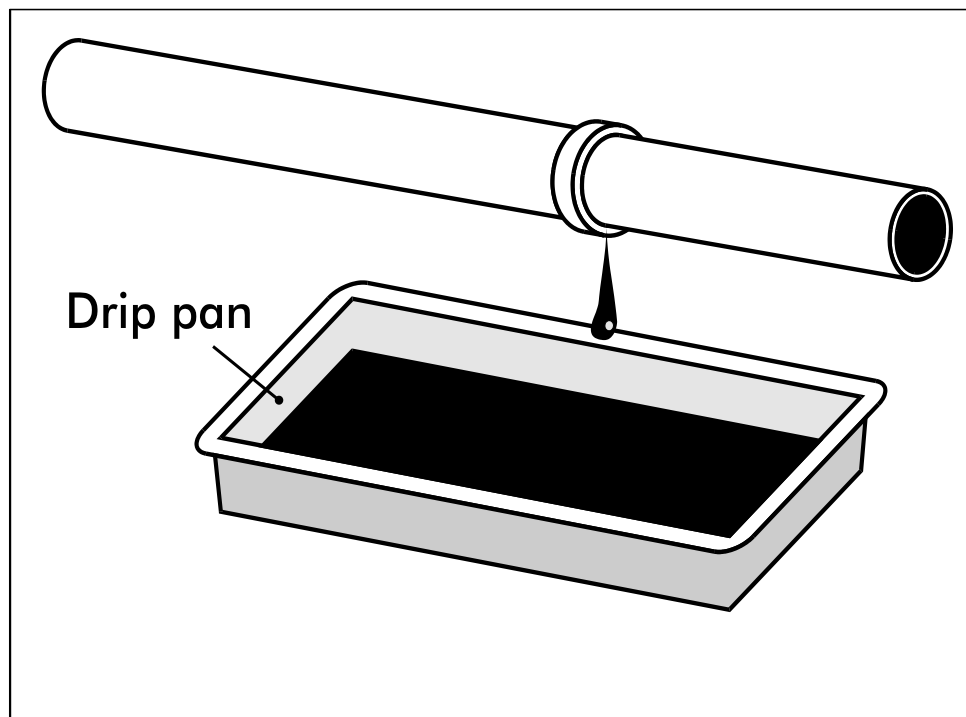
#### 4.3.1.1 Description of Pollutant Sources

Loading/unloading of liquid and solid materials at industrial and commercial facilities is typically conducted at shipping and receiving, outside storage, fueling areas, etc. Materials transferred can include products, raw materials, intermediate products, waste materials, fuels, scrap metals, etc. Leaks and spills of fuels, oils, powders, organics, heavy metals, salts, acids, alkalis, etc. during transfer are potential causes of stormwater contamination. Spills from hydraulic line breaks are a common problem at loading docks.

#### 4.3.1.2 Required BMPs

##### *At All Loading/ Unloading Areas:*

- Sweep loading/unloading areas frequently to remove accumulated material. Vacuum sweeping is also an acceptable method of removing accumulated material.
- Place drip pans or other appropriate temporary containment devices at locations where leaks or spills may occur such as hose connections, hose reels, and filler nozzles. Drip pans shall always be used when making and breaking connections (see Figure 4 - 1). Check loading/unloading equipment such as valves, pumps, flanges, and connections regularly for leaks and repair as needed. Frequent monitoring of drip pans is required to ensure captured materials are not displaced by wind or rainwater.



*Figure 4 - 1. Drip Pan*

- Washing loading/unloading areas must be conducted in such a way that all the runoff is collected for proper disposal. Refer to Volume 4, Section 4.2.
- Conduct unloading or loading of solids and liquids in a manufacturing building or under a roof, lean-to, or other appropriate cover, consistent with Uniform Fire Code requirements and to the extent practicable.
- Berm, dike, and/or slope the loading/unloading area to prevent run-on of stormwater and to prevent the runoff or loss of any spilled material from the area.
- Place curbs along the edge, or slope the edge such that the stormwater can flow to an internal storm drain system that leads to an approved treatment BMP. Large loading areas frequently are not curbed along the shoreline. As a result, stormwater passes directly off the paved surface into surface water.
- Pave and slope loading/unloading areas to prevent the pooling of water. The use of catch basins and drain lines within the interior of the paved area must be minimized as they will frequently be covered by material, or they shall be placed in designated "alleyways" that are not covered by material, containers, or equipment.

***At Tanker Truck and Rail Transfer Areas to Above/Below-ground Storage Tanks:***

- Prepare an "Operations Plan" that describes procedures for loading/unloading to minimize the risk of accidental spillage. Train the employees in its execution and post it or otherwise have it readily available to employees.
- Report spills of reportable quantities to Ecology Southwest Regional Office (refer to Chapter 1 for telephone number).
- Prepare and implement an Emergency Spill Cleanup Plan for the facility (BMP A714 Spills of Oil and Hazardous Substances) which includes the following BMPs:
  - Ensure the clean up of liquid/solid spills in the loading/unloading area immediately if a significant spill occurs, upon completion of the loading/unloading activity, or at the end of the working day.
  - Retain and maintain an appropriate oil spill cleanup kit on-site for rapid cleanup of material spills (see BMP A714 Spills of Oil and Hazardous Substances).
  - Ensure that an employee trained in spill containment and cleanup is present during loading/unloading.

***At Rail Transfer Areas to Above/Below-ground Storage Tanks:***

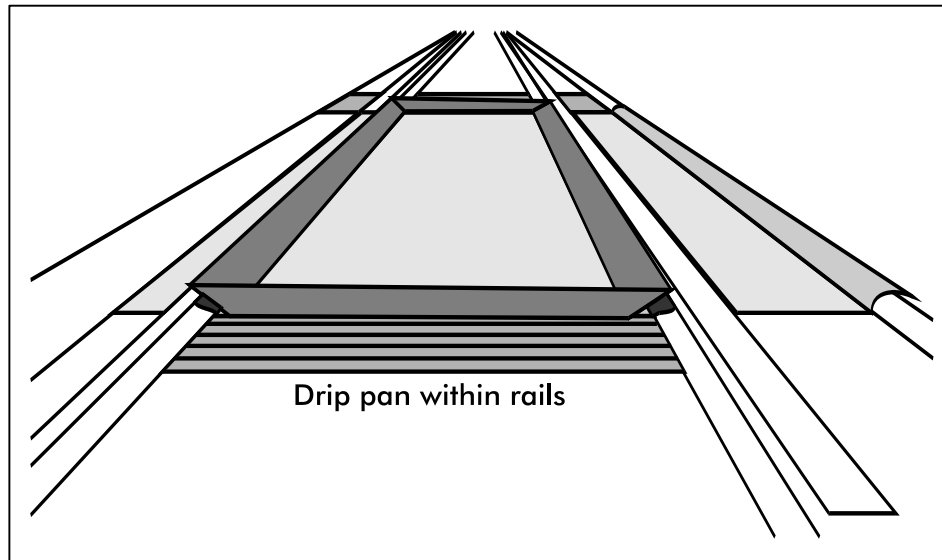
Install a drip pan system as illustrated (see Figure 4 - 2) within the rails to collect spills/leaks from tank cars and hose connections, hose reels, and filler nozzles.

***Loading/Unloading from/to Marine Vessels:***

Facilities and procedures for the loading or unloading of petroleum products must comply with Coast Guard requirements.

***Transfer of Small Quantities from Tanks and Containers:***

Refer to BMPs A408 Storage of Liquids in Permanent Above-Ground Tanks and A407 Storage of Liquid, Food Waste, or Dangerous Waste Containers for requirements on the transfer of small quantities from tanks and containers, respectively.



*Figure 4 - 2. Drip Pan Within Rails*

#### **4.3.1.3 Recommended BMPs:**

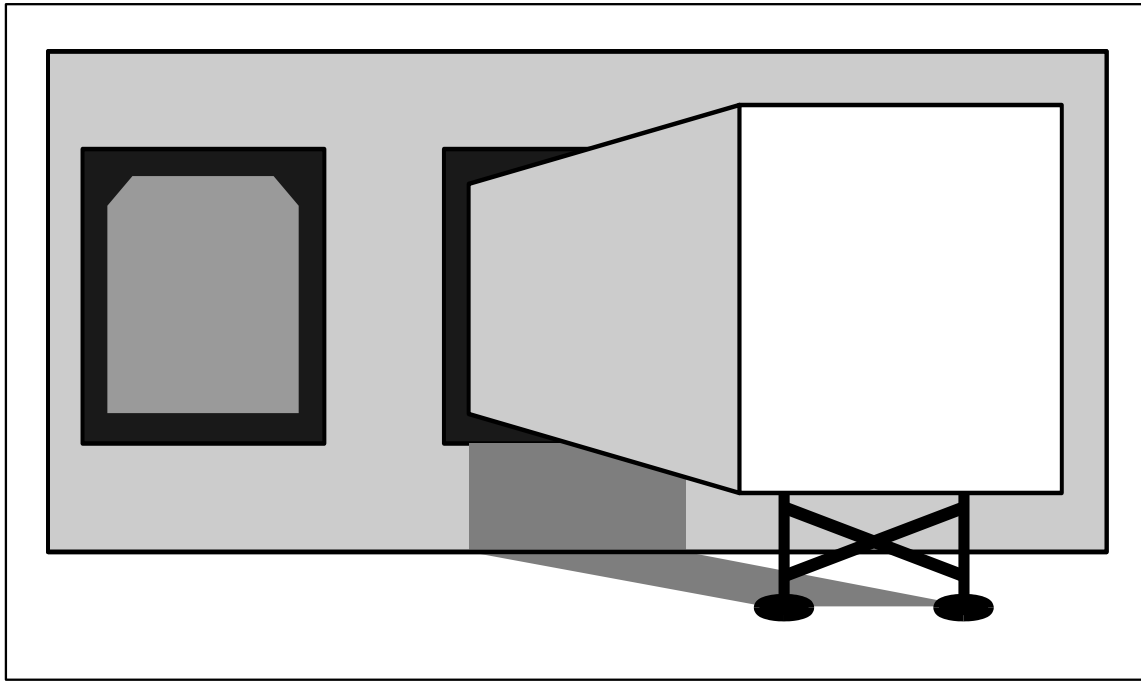
- Install an automatic shutoff system in the product transfer lines or other location that will minimize the release of product in the event of unanticipated off-loading interruption (e.g. coupling break, hose rupture, overfill, etc.).

#### ***At Loading and Unloading Docks:***

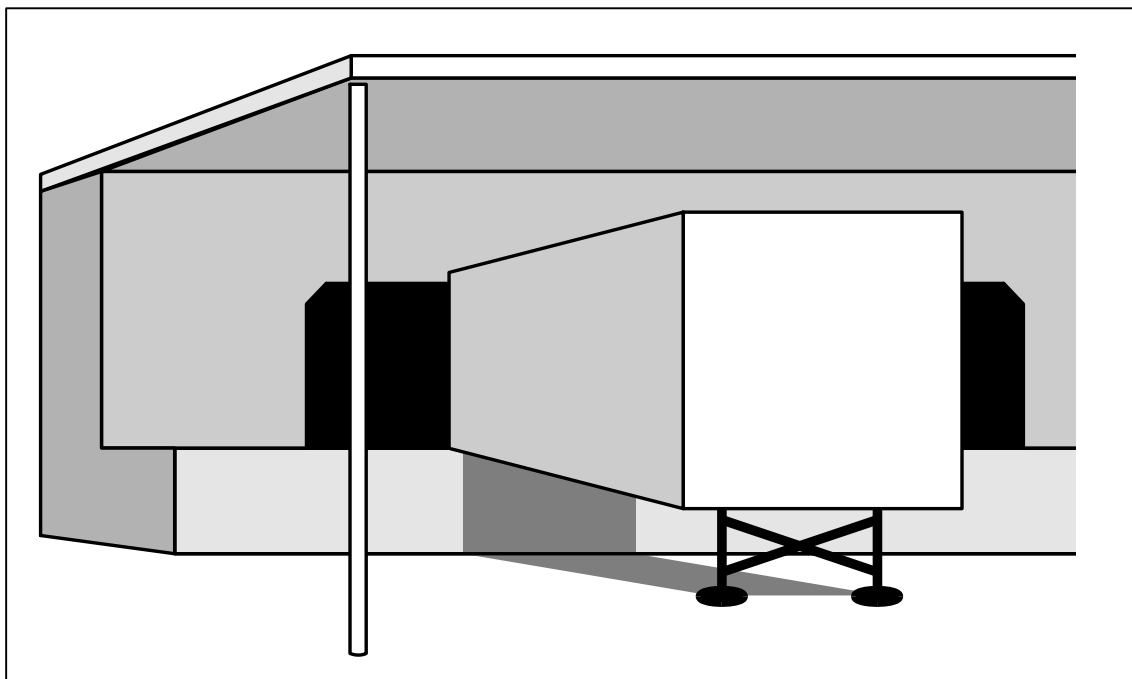
- Install/maintain overhangs or door skirts that enclose the trailer end (see Figure 4 - 3 and Figure 4 - 4) to prevent contact with rainwater.
- Design the loading/unloading area with berms, sloping, etc. to prevent the run-on of stormwater.
- Retain on-site the necessary materials for rapid cleanup of spills.

#### ***At Tanker Truck Transfer Areas to Above/Below-Ground Storage Tanks:***

- Pave the area on which the transfer takes place. If any transferred liquid, such as gasoline, is reactive with asphalt, pave the area with Portland cement concrete.
- Slope, berm, or dike the transfer area to a dead-end sump, spill containment sump, spill control (SC) oil/water separator, or other spill control device. The minimum spill retention time should be 15 minutes at the highest fuel dispenser nozzle through-put rate or the peak flow rate of the 6-month, 24-hour storm event over the surface of the containment pad, whichever is greater. The volume of the spill containment sump should be a minimum of 50 gallons with an adequate grit sedimentation volume.



**Figure 4 - 3. Loading Dock with Door Skirt**



**Figure 4 - 4. Loading Dock with Overhang**

### **4.3.2 BMP A202: Fueling at Dedicated Stations**

#### **4.3.2.1 Description of Pollutant Sources**

A fueling station is a facility dedicated to the transfer of fuels from a stationary pumping station to mobile vehicles or equipment. It includes above or underground fuel storage facilities. In addition to general service gas stations, fueling may also occur at 24-hour convenience stores, construction sites, warehouses, car washes, manufacturing establishments, port facilities, and businesses with fleet vehicles. Typically, stormwater contamination at fueling stations is caused by leaks/spills of fuels, lube oils, radiator coolants, and vehicle washwater.

#### **4.3.2.2 Required BMPs**

##### ***General Requirements***

- Fuel islands shall not drain into the storm drainage system.
- Fuel islands may provide blind sumps for spill containment, or they may drain into the sanitary sewer through a properly sized oil/water separator.
- Follow the City of Tacoma Source Control Oil Water Separator policy available at [www.cityoftacoma.org/stormwater](http://www.cityoftacoma.org/stormwater). The policy provides guidance for both covered and uncovered fuel islands.

### **4.3.3 BMP A203: Vehicle Maintenance Activities**

#### **4.3.3.1 Description of Pollutant Sources**

This activity applies to businesses and public agencies where fuel filters, engine oil, and other fluids such as battery acid, coolants, and transmission and brake fluids are removed and replaced in vehicles and equipment. It also applies to mobile vehicle maintenance operations, such as at construction sites. Related vehicle maintenance activities are covered under the following activity headings in this manual, and other BMPs provided in this manual:

BMP W100	Washing, Pressure Washing, and Steam Cleaning of Vehicles/Equipment/Building Structures
A201	Loading and Unloading Areas for Liquid or Solid Material
A202	Fueling at Dedicated Stations
A204	Mobile Fueling
A307	Painting, Finishing and Coating of Vehicles, Boats, Buildings, and Equipment
A401	Storage or Transfer (Outside) of Solid Raw Materials, By-Products, or Finished Products
A407	Storage of Liquid, Food Waste, or Dangerous Waste Containers
A409	Storage of Liquids in Permanent Above-ground Tanks
A410	Parking and Storage for Vehicles and Equipment
A713	Spills of Oil and Hazardous Substances

Pollutants of concern include toxic hydrocarbons, toxic organic compounds, oils and greases, pH, and heavy metals.

#### **4.3.3.2 Required BMPs**

The following BMPs or equivalent measures are required of all businesses and agencies engaged in engine and vehicle repair:

- Inspect all incoming vehicles, parts, and equipment stored temporarily outside, for leaks.
- Employees must be educated about the need for careful handling of automotive fluids. Employees at businesses or agencies who routinely change or handle these fluids must be trained in spill response and cleanup procedures. Inspect all incoming vehicles, parts, and equipment stored temporarily outside for leaks.
- Remove batteries and liquids from vehicles and equipment in designated areas designed to prevent stormwater contamination. Store cracked batteries in a covered non-leaking secondary containment system.
- Empty fuel and fuel filters before disposal.
- Spill cleanup materials, such as rags and absorbent materials, must always be kept close at hand when changing oil and other fluids. Soiled rags and other cleanup material must be properly disposed of or cleaned and reused.
- Floor drains inside buildings shall connect to sanitary sewer, be routed through an appropriately sized oil/water separator and shall be approved by the City.
- Do not hose down the maintenance/repair area. Instead, sweep the area weekly to collect dirt, and wipe up spills with rags and other absorbent materials.
- A bermed tarp, ground cloth, or drip pans must be used beneath the vehicle or equipment to capture all spills and drips. The collected drips and spills must be recycled or disposed of properly. See BMP S102 for disposal options.
- If this activity occurs at a stationary business location, the activity area must be moved indoors. An exception to this requirement would be equipment that is too large to fit under a roofed area. In this case, the outdoor area must be paved, provided with a sump drain, and provision made for stormwater runoff prevention. See BMP S106 and S107 for more on paving, sump drains and holding tanks, and runoff prevention. Contact the City of Tacoma Sanitary Source Control unit at 253-591-5588 for information on requirements for disposal to sewer. If the site utilizes a septic tank, sump contents will need to be pumped and disposed of by an oil recycler or hazardous waste company.
- Recycle oil, antifreeze, batteries, and air conditioning coolant.
- If engine washing is to be performed, then appropriate pretreatment will be required. Contact the City of Tacoma Source Control Unit at 253-591-5588 for their requirements.
- Convey contaminated stormwater runoff from vehicle staging and maintenance areas to the wastewater system if allowed by Environmental Services. Alternatively, if not allowed, convey contaminated stormwater to an oil water separator followed by a basic treatment BMP or other equivalent oil treatment BMP.

#### **4.3.3.3 Recommended BMPs**

The following BMPs are not required, but can provide additional pollution prevention.

- Drain all fluids from wrecked vehicles and car parts upon arrival. Recover air conditioning gases.

- Use reusable cloth rags to clean up drips and small spills instead of disposables: these can be professionally laundered and reused. Do not attempt to launder these at home or at a coin-op laundry.
- Use absorbent pillows or booms in or around storm drains and catch basins to absorb oil and fuel.
- Maintain vehicles under cover where possible.

#### **4.3.4 BMP A204: Mobile Fueling of Vehicles and Heavy Equipment**

##### **4.3.4.1 Description of Pollutant Sources**

Mobile fueling, also known as fleet fueling, wet fueling, or wet hosing, is the practice of filling fuel tanks of vehicles by tank trucks that are driven to the yards or sites where the vehicles to be fueled are located. Mobile fueling is only conducted using diesel fuel, as mobile fueling of gasoline is prohibited. Diesel fuel is considered a Class II Combustible Liquid, whereas gasoline is considered a Flammable Liquid.

Historically mobile fueling has been conducted for off-road vehicles that are operated for extended periods of time in remote areas. This includes construction sites, logging operations, and farms. Mobile fueling of on-road vehicles is also conducted commercially in the State of Washington.

##### **4.3.4.2 Required BMPs**

Organizations and individuals conducting mobile fueling operations must implement the following BMPs. The operating procedures for the driver/operator shall be simple, clear, effective and their implementation verified by the organization that will potentially be liable for environmental and third party damage.

- Ensure that all mobile fueling operations are approved and permitted by Tacoma Fire Prevention Bureau and comply with local and Washington State fire codes. Contact the Tacoma Fire Prevention Bureau at 253-591-5740 to obtain the annual permit.
- Fueling locations that are in close proximity to sensitive aquifers, designated wetlands, wetland buffers, or other waters of the State, require approval by the City of Tacoma to ensure compliance with additional local requirements. Ensure compliance with TMC 3.10.
- Ensure compliance with all 49 CFR 178 requirements for DOT 406 cargo tanker. Documentation from a Department of Transportation (DOT) Registered Inspector shall be proof of compliance.
- Ensure the presence and the constant observation/monitoring by the driver/operator at the fuel transfer location at all times during fuel transfer and ensure that the following procedures are implemented at the fuel transfer locations:
  - Locate the point of fueling:
    - At least 25 feet from the nearest storm drain, or
    - Inside an impervious containment area with a volumetric holding capacity equal to or greater than 110 percent of the receiving tank volume, or
    - Place an impervious cover over the storm drain to ensure no inflow of spilled or leaked fuel.

- Storm drains that convey the inflow to a spill control separator approved by the City of Tacoma, including the Tacoma Fire Department, need not be covered. Potential spill/leak conveyance surfaces must be impervious and in good repair
- Place a drip pan or an absorbent pad under each fueling location prior to and during all dispensing operations. The pan (must be liquid tight) and the absorbent pad must have a capacity of 3 gallons. Spills retained in the drip pan or the pad need not be reported.
  - Handle and operate fuel transfer hoses and nozzle, drip pan(s), and absorbent pads to prevent spills/leaks of fuel from reaching the ground, storm drains, and receiving waters.
  - Do not extend the fueling hoses across a traffic lane without fluorescent traffic cones, or equivalent devices.
  - Remove the fill nozzle and cease filling when the automatic shut-off valve engages. Do not allow automatic shutoff fueling nozzles to be locked in the open position.
  - Do not “top off” the equipment receiving fuel.
  - Provide the driver/operator of the fueling vehicle with:
    - Adequate headlamps, flashlights or other mobile lighting to view fill openings with poor accessibility. Consult with the Tacoma Fire Department for additional lighting requirements.
    - Two-way communication with home base.
  - Train the driver/operator annually in spill prevention, reporting and cleanup measures and emergency procedures. Make all employees aware of the significant liability associated with fuel spills.
  - The fueling operation procedures shall be properly signed and dated by the responsible manager, distributed to the operators, retained in the organization files, and made available in the event an authorized government agency requests a review.
  - Ensure that the Tacoma Fire Department (911) and the Ecology Southwest Regional Office are immediately notified in the event of any spill entering surface or groundwaters, including catch basins. Establish a 24-hour “call down list” to ensure the rapid and proper notification of management and government officials should any amount of product be spilled on-site. Keep the list in a protected but readily accessible location in the mobile fueling truck. The “call down list” shall also pre-identify spill response contractors available in the area to ensure the rapid removal of significant product spillage into the environment.
  - Maintain a minimum of the following spill clean-up materials in all fueling vehicles, that are readily available for use:
    - Non-water absorbents (pads, pillows, sump skimmers) capable of absorbing 15 gallons of diesel fuel;
    - A storm drain plug or cover kit;
    - A non-water absorbent containment boom of a minimum 10 feet in length with a 12-gallon absorbent capacity;
    - A non-metallic shovel; and
    - Two, five-gallon buckets with lids.



- Loose granular absorbent material capable of absorbing a minimum of 5 gallons of diesel. Use only non-water absorbing materials, such as peat moss, during wet weather conditions.
- Use automatic shutoff nozzles for dispensing the fuel. Replace automatic shut-off nozzles as recommended by the manufacturer.
- Maintain and replace equipment on fueling vehicles, particularly hoses and nozzles, at established intervals to prevent failures.
- Do not overfill tanks. Allow room for heat expansion of fuel during warm weather.
- Include the following fuel transfer site components:
  - Automatic fuel transfer shut-off nozzles; and
  - An adequate lighting system at the filling point.

## **4.4 Production and Application Activities**

### **4.4.1 BMP A301: Concrete and Asphalt Mixing and Production at Stationary Sites**

#### **4.4.1.1 Description of Pollutant Sources**

This activity applies to businesses and agencies that mix raw materials onsite to produce concrete or asphalt. It also applies to subsequent uses such as pouring concrete structures and making other concrete or asphalt products. Mobile concrete pouring and asphalt application are covered under BMP A302. Requirements for stockpiling of raw materials are covered under BMP A401 Storage or Transfer (Outside) of Solid Raw Materials, By-products or Finished Products.

Pollutants of concern include toxic hydrocarbons, toxic organic compounds, oils and greases, heavy metals, and pH.

#### **4.4.1.2 Required BMPs**

The following BMPs or equivalent measures are required of all businesses and public agencies active in concrete and asphalt mixing and production:

- Eliminate all illicit connections to the storm drainage system. See BMP S101 for a detailed discussion on identifying and eliminating these connections.
- All process water from production, pouring, and equipment cleaning must be discharged to a dead-end sump, a process water treatment system, connected to the sanitary sewer, or recycled. Never wash fresh concrete or concrete mixer washout into streets, storm drainage systems, streams, or other water bodies.
- A BMP maintenance schedule must be established, maintenance documented, and employees educated about the need to prevent stormwater contamination through the use and proper maintenance of BMPs.
- Production and pouring areas must be protected from stormwater run-on. See BMP S107 for methods of run-on protection.
- Cover the production area for prevention of stormwater run-on. See BMP S104 and S107 for information on covers and run-on prevention.
- Use absorbent materials or catch basin filters in and around storm drains and catch basins to filter out contaminants.
- Contact the Washington State Department of Ecology at 360-407-6400 to determine if an NPDES Sand and Gravel General Permit is required for your site.
- Sweep areas that show accumulation of materials. Vacuum sweeping is also an acceptable method of removing accumulated material.

#### **4.4.1.3 Recommended BMPs**

The following BMPs are not required, but can provide additional pollution protection:

- The production and pouring area should be swept at the end of each work day to collect loose chunks of aggregate and raw materials for recycling or proper disposal. See BMP S102 for disposal options.
- Asphalt plants should use an oil/water separator to treat stormwater runoff. See Volume 5, Water Quality Treatment BMPs, for more information.
- Pave the mixing, production, and pouring areas. A sump drain in these areas is probably not advisable due to potential clogging problems, but could be used in a curing area. Sweep these areas to remove loose aggregate and recycle or dispose of properly.

#### **4.4.2 BMP A302: Concrete Pouring, Concrete Cutting, and Asphalt Application at Temporary Sites**

##### **4.4.2.1 Description of Pollutant Sources**

This activity applies to businesses and public agencies that apply asphalt or pour or cut concrete for building construction and remodeling, road construction, utility projects, sidewalk, curb and gutter repairs and construction, sealing of driveways and roofs, and other applications. These activities are typically done on a temporary site-to-site basis where permanent BMP measures do not apply. Concrete pouring activities can not only severely alter the pH of receiving waters, but slurry from aggregate washing can harden in storm pipes, thus reducing capacity and creating flooding problems.

Pollutants of concern include toxic hydrocarbons, toxic organic compounds, oils and greases, heavy metals, suspended solids, and pH.

##### **4.4.2.2 Required BMPs**

The following BMPs or equivalent measures are required of all businesses and agencies doing concrete pouring and asphalt application at temporary sites:

- Employees must be educated on the pollution hazards of concrete and asphalt application and cutting.
- Loose aggregate chunks and dust must be swept or shoveled and collected (not hosed down a storm drain) for recycling or proper disposal at the end of each work day, especially at work sites such as streets, driveways, parking lots, sidewalks, curbs, and gutters where rain can readily pick up the loose material and carry it to the nearest stormwater conveyance system. Small amounts of excess concrete, grout, and mortar can be disposed of in the trash.
- Storm drain covers or similarly effective containment devices must be placed over all nearby drains at the beginning of each day. Shovel or vacuum slurry and remove from the site. All accumulated runoff and solids must be collected and properly disposed (see BMP S102 for disposal options) at the end of each work day, or more often if necessary.
- Exposed aggregate washing, where the top layer of unhardened concrete is hosed or scraped off to leave a rough finish, must be done with a mechanism for containment and collection of the discarded concrete slurry (such as the storm drain covers mentioned above).

- Cleaning of concrete application and mixing equipment or concrete vehicles on the work site must be done in a designated area where the rinse water is controlled. Follow BMP C151 and BMP C154 in Volume 2.
- Comply with the following BMPs in Volume 2 as applicable:
  - BMP C151: Concrete Handling
  - BMP C152: Sawcutting and Surface Pollution Prevention
  - BMP C154: Concrete Washout Area

The use of any treatment BMP must not result in the violation of groundwater, surface water, or drinking water quality standards.

#### **4.4.2.3 Recommended BMPs**

The following BMPs are not required but can provide additional pollution prevention:

- Avoid the activity when rain is occurring or expected.
- If possible, portable asphalt mixing equipment should be covered by an awning, a lean-to, or another simple structure to avoid contact with rain. See BMP S104 for further details on cover structures.
- Recycle broken concrete and asphalt. Look under Recycling Services in the Yellow pages of the phone book to find the nearest recycler.

### **4.4.3 BMP A303: Manufacturing and Post-Processing of Metal Products**

#### **4.4.3.1 Description of Pollutant Sources**

This activity applies to businesses such as mills, foundries, and fabricators that manufacture or post-process metal products. A variety of activities such as machining, grinding, soldering, cutting, welding, quenching, cooling, and rinsing may take place. These businesses may be required to obtain a National Pollutant Discharge Elimination System (NPDES) permit from the Department of Ecology or an Industrial Wastewater Discharge Permit from the City of Tacoma.

- Contact the Washington State Department of Ecology at 360-407-7541 for questions related to NPDES Industrial Stormwater Permitting.
- Contact the City of Tacoma Source Control at 253-591-5588 to determine if a City of Tacoma Industrial Wastewater Discharge Permit is necessary.

**NOTE:** Painting, finishing and coating of metal products is covered under BMP A307 Painting, Finishing, and Coating of Vehicles, Boats, Buildings, and Equipment.

Pollutants of concern include toxic organic compounds, heavy metals, oils and greases, pH, suspended solids, and biological oxygen demand (BOD).

#### **4.4.3.2 Required BMPs**

The following BMPs or equivalent measures are required of all businesses engaged in metals manufacturing or post-processing:

- Eliminate illicit connections to the storm drainage system. See BMP S101 for detailed information on identifying and eliminating illicit connections.
- Process wastewater (including contact cooling water, filter backwash, cooling tower blowdown, etc.), and stormwater runoff from activity areas, must discharge to a sanitary sewer, holding tank, or process treatment system before discharge to surface water or

storm drain. Contact the City of Tacoma Source Control at 253-591-5588 to obtain permits for discharge to the sewer. See BMP S103 for detailed requirements.

- Employees must be educated to control their work with metal products to minimize pollution.
- The activity area must be swept at the end of each work day to collect and dispose of metal fragments and product residues properly. See BMP S102 for disposal alternatives.

#### **4.4.3.3 Recommended BMPs**

The following BMPs are not required but can provide additional pollution protection:

- Limit the amount of water used in quenching and rinsing. Recycle used water where possible.
- Cover the activity area to prevent rain from contacting the process and reduce the amount of runoff that has to be detained or treated.
- Use a catch basin filter or screen basket insert to capture stray metal particles.
- Implement a program to track purchase and consumption of lubricants, solvents, and additives. Check with operating managers for an explanation if consumption increases. Recommend actions if significant equipment leaks or spills are identified.
- Utilize any additional BMPs which are applicable for materials storage and maintenance activities in your shop.

#### **4.4.4 BMP A304: Wood Treatment Areas**

##### **4.4.4.1 Description of Pollutant Sources**

Wood treatment includes both anti-staining and wood preserving using pressure processes or by dipping or spraying. Wood preservatives and anti-staining chemical additives can include petroleum products, pesticides and heavy metals.

Pollutant sources include drips of condensate or preservative after pressurized treatment, product washwater (in the treatment or storage areas), spills and leaks from process equipment and preservative tanks, fugitive emissions from vapors in the process, blowouts and emergency pressure releases, and kick-back from lumber (phenomenon where preservative leaks as it returns to normal pressure). Potential pollutants typically include the wood treating chemicals, BOD, suspended solids, oil and grease, benzene, toluene, ethylbenzene, phenol, chlorophenols, nitrophenols, heavy metals, and PAH, depending on the chemical additive used.

##### **4.4.4.2 Required BMPs**

All wood treating facilities in Washington State are required to be covered under an Individual NPDES Permit and may require an Industrial Wastewater Discharge Permit from the City of Tacoma. The individual NPDES Permit will describe the BMPs applicable to the site.

#### **4.4.5 BMP A305: Commercial Composting**

##### **4.4.5.1 Description of Pollutant Sources**

Commercial compost facilities operating outside without cover require large areas to decompose wastes and other feedstocks. These facilities should be designed to separate stormwater from leachate (i.e., industrial wastewater) to the greatest extent possible. When stormwater is allowed to contact any active composting areas, including waste receiving and processing areas, it

becomes leachate. Pollutants in leachate include nutrients, biochemical oxygen demand (BOD), organics, coliform bacteria, acidic pH, color, and suspended solids. Stormwater at a compost facility consists of runoff from areas at the facility that are not associated with active processing and curing, such as product storage areas, vehicle maintenance areas, and access roads.

#### **4.4.5.2 Required BMPs for Commercial Composting**

Commercial composting facilities are required to be covered under an Individual NPDES Permit and may require an Industrial Wastewater Discharge Permit from the City of Tacoma.

- Commercial composting facilities shall comply with WAC 173-350-220, Composting Facilities.
- Develop a plan of operations as outlined in the Composting Facility Standards (WAC 173-350-220) and in the Individual NPDES Permit.

#### **4.4.5.3 Recommended BMPs for Commercial Composting**

- Review the Washington State Department of Ecology (Ecology) publication which contains guidance for common practices that a facility can adopt to help run a successful program: Siting and Operating Composting Facilities in Washington State: Good Management Practices. This document is available at: <https://fortress.wa.gov/ecy/publications/summarypages/1107005.html>
- Review Ecology's Organic Materials Management Rules and Laws page for the information concerning composting facilities: <http://www.ecy.wa.gov/programs/swfa/organics/law.html>.

### **4.4.6 BMP A306: Landscaping and Lawn/Vegetation Management**

#### **4.4.6.1 Description of Pollutant Sources**

Landscaping can include grading, soil transfer, vegetation removal, pesticide and fertilizer application, and watering. Stormwater contaminants include toxic organic compounds, heavy metals, oils, total suspended solids, coliform bacteria, fertilizers, and pesticides.

Lawn and vegetation management can include control of objectionable weeds, insects, mold, bacteria, and other pests with chemical pesticides and is conducted commercially at commercial, industrial, and residential sites. Examples include weed control on golf course lawns, access roads, and utility corridors and during landscaping; sap stain and insect control on lumber and logs; rooftop moss removal; killing nuisance rodents; fungicide application to patio decks; and residential lawn/plant care. Toxic pesticides such as pentachlorophenol, carbamates, and organometallics can be released to the environment by leaching and dripping from treated parts, container leaks, product misuse, and outside storage of pesticide contaminated materials and equipment. Poor management of the vegetation, poor application of pesticides or fertilizers, and non-targeted irrigation water or overwatering can cause appreciable stormwater contamination.

#### **4.4.6.2 Required BMPs for Landscaping**

- Install engineered soil/landscape systems to improve the infiltration and regulation of stormwater in landscaped areas. Apply BMP L613 Post-Construction Soil Quality and Depth BMPs as required per Minimum Requirement #5.
- Do not dispose of collected vegetation into wetlands, waterways or storm drainage systems.

#### **4.4.6.3 Recommended BMPs for Landscaping**

- Conduct mulch-mowing whenever practicable.
- Dispose of grass clippings, leaves, sticks, or other collected vegetation by composting, if feasible.
- Collect all clippings, leaves, bark, and trimmings blown onto the sidewalk or street. Don't leave this material in the gutter or where it can be washed into the storm drainage system.
- Use mulch or other erosion control measures when soils are exposed for more than one week during the dry season or two days during the rainy season.
- If oil or other chemicals are handled, store and maintain appropriate oil and chemical spill cleanup materials in readily accessible locations. Ensure that employees are familiar with proper spill cleanup procedures.
- Test soil before applying fertilizer to determine need for fertilization and appropriate type of fertilizer. Select fertilizers that are derived from natural and organic materials instead of synthetic chemical fertilizers. Till fertilizers into the soil rather than dumping or broadcasting onto the surface. Determine the proper fertilizer application for the types of soil and vegetation encountered.
- Till a topsoil mix or composted organic material into the soil to create a well-mixed transition layer that encourages deeper root systems and drought-resistant plants.
- Use manual and/or mechanical methods of vegetation removal rather than applying herbicides, where practical.
- Target irrigation water on vegetated areas and limit irrigation time to reduce the potential of carrying fertilizers and pesticides off-site.
- Plant growing trees. For more information on growing trees visit [www.cityoftacoma.org/urbanforestry](http://www.cityoftacoma.org/urbanforestry). Properly prune all trees

#### **4.4.6.4 Required BMPs for the Use of Pesticides**

- Develop and implement an integrated pest management system (IPM) (See BMP S108) and use pesticides only as a last resort.
- Implement a pesticide-use plan and include at a minimum: a list of selected pesticides and their specific uses; brands, formulations, application methods, and quantities to be used; equipment use and maintenance procedures; safety, storage, and disposal methods; and monitoring, record keeping, and public notice procedures. All procedures shall conform to the requirements of Chapter 17.21 RCW and Chapter 16-228 WAC (Appendix 4 – D.R.7).
- Choose the least toxic pesticide available that is capable of reducing the infestation to acceptable levels. The pesticide should readily degrade in the environment and/or have properties that strongly bind it to the soil. Any pest control used should be conducted at the life stage when the pest is most vulnerable. Any method used should be site-specific and not used wholesale over a wide area.
- Apply the pesticide according to label directions. Under no conditions shall pesticides be applied in quantities that exceed manufacturer's instructions.
- Mix the pesticides and clean the application equipment in an area where accidental spills will not enter surface or groundwaters, and will not contaminate the soil.

- Store pesticides in enclosed areas or in covered impervious containment. Ensure that pesticide contaminated stormwater or spills/leaks of pesticides are not discharged to storm drains. Do not hose down paved areas to a storm drain or conveyance ditch. Store and maintain appropriate spill cleanup materials in a location known to all near the storage area.
- Clean up any spilled pesticides and ensure that the pesticide contaminated waste materials are kept in designated covered and contained areas.
- The pesticide application equipment must be capable of immediate shutoff in the event of an emergency.
- Do not spray pesticides within 100 feet of open waters including wetlands; ponds; and streams, sloughs, and any drainage ditch or channel that leads to open water, except when approved by Ecology or by the City of Tacoma. All sensitive areas including wells, creeks, and wetlands must be flagged prior to spraying.
- As required by the City of Tacoma or by Ecology, complete public posting of the area to be sprayed prior to the application.
- Spray applications should only be conducted during weather conditions as specified in the label direction and applicable local and state regulations. Do not apply during rain or immediately before expected rain.
- Pesticides shall not be applied to stormwater management facilities.

#### **4.4.6.5 Recommended BMPs for the use of Pesticides**

- Consider alternatives to the use of pesticides such as covering or harvesting weeds, substitute vegetative growth, and manual weed control/moss removal.
- Consider the use of soil amendments, such as compost, that are known to control some common diseases in plants, such as Pythium root rot, ashy stem blight, and parasitic nematodes. The following are three possible mechanisms for disease control by compost addition (USEPA Publication 530-F-9-044):
  - Successful competition for nutrients by antibiotic production;
  - Successful predation against pathogens by beneficial microorganism; and
  - Activation of disease-resistant genes in plants by composts.

Installing an amended soil/landscape system can preserve both the plant system and the soil system more effectively. This type of approach provides a soil/landscape system with adequate depth, permeability, and organic matter to sustain itself and continue working as an effective stormwater infiltration system and a sustainable nutrient cycle.

- Once a pesticide is applied, its effectiveness should be evaluated for possible improvement. Records should be kept showing the applicability and inapplicability of the pesticides considered.
- An annual evaluation procedure should be developed including a review of the effectiveness of pesticide applications, impact on buffers and sensitive areas (including potable wells), public concerns, and recent toxicological information on pesticides used/proposed for use. If individual or public potable wells are located in the proximity of commercial pesticide applications, contact the regional Ecology hydrologist to determine if additional pesticide application control measures are necessary.
- Rinsate from equipment cleaning and/or triple-rinsing of pesticide containers should be used as product or recycled into product.



For more information, contact the WSU Extension Home-Assist Program at 253-445-4500; Bio-Integral Resource Center (BIRC), P.O. Box 7414, Berkeley, CA 94707; or the Washington Department of Ecology to obtain “Hazardous Waste Pesticides” (Publication #89-41); contact EPA to obtain a publication entitled “Suspended, Canceled and Restricted Pesticides” which lists all restricted pesticides and the specific uses that are allowed. Valuable information from these sources may also be available on the internet.

#### **4.4.6.6 Required BMPs for Vegetation Management**

- Use at least an eight-inch topsoil layer with at least 8 percent organic matter to provide a sufficient vegetation-growing medium.
- Select the appropriate turf grass mixture for climate and soil type based on recommendations from a licensed landscape architect.
- Selection of desired plant species can be made by adjusting the soil properties of the subject site. For example, a constructed wetland can be designed to resist the invasion of reed canary grass by layering specific strata of organic matters (e.g., compost forest product residuals) and creating a mildly acidic pH and carbon-rich soil medium. Consult a soil restoration specialist for site-specific conditions.
- Aerate lawns regularly in areas of heavy use, where the soil tends to become compacted. Aeration shall be conducted while the grasses in the lawn are growing most vigorously. Remove layers of thatch greater than ¾-inch deep.
- Set the mowing height at the highest acceptable level and mow at times and intervals designed to minimize stress on the turf. Generally mowing only 1/3 of the grass blade height will prevent stressing the turf.

#### **4.4.6.7 Required BMPs for the Use of Fertilizers**

- Fertilization needs vary by site depending on plant, soil, and climatic conditions. Evaluation of soil nutrient levels through regular testing ensures the best possible efficiency and economy of fertilization. For details on soils testing, contact the Pierce Conservation District or Cooperative Extension Service.
- Fertilizers shall be applied in amounts appropriate for the target vegetation and at the time of year that minimizes losses to surface and groundwaters. Do not fertilize during a drought or when the soil is dry. Alternatively, do not apply fertilizers within three days prior to predicted rainfall. The longer the period between fertilizer application and either rainfall or irrigation, the less fertilizer runoff occurs.
- Use slow release fertilizers such as methylene urea, IDBU, or resin coated fertilizers when appropriate, generally in the spring. Use of slow release fertilizers is especially important in areas with sandy or gravelly soils.
- Time the fertilizer application to periods of maximum plant uptake. Generally fall and spring applications are recommended.
- Properly trained persons shall apply all fertilizers. Fertilizers shall not be applied to grass swales, filter strips, or buffer areas that drain to surface water bodies.
- Fertilizers shall not be applied to stormwater management facilities.

#### **4.4.7 BMP A307: Painting, Finishing and Coating of Vehicles, Boats, Buildings and Equipment**

##### **4.4.7.1 Description of Pollutant Sources**

Surface preparation and the application of paints, finishes, and/or coatings to vehicles, boats, buildings, and/or equipment outdoors can be sources of pollutants. Potential pollutants include organic compounds, oils and greases, heavy metals, and suspended solids.

##### **4.4.7.2 Required BMPs**

- Train employees in the careful application of paints, finishes, and coatings to reduce misuse and over spray. Use ground or drop cloths or temporary berms underneath outdoor painting, scraping, sandblasting work, and properly clean and temporarily store collected debris daily.
- Do not conduct spraying, blasting, or sanding activities over open water or where wind may blow paint into water.
- Wipe up spills with rags and other absorbent materials immediately. Do not hose down the area to a storm drain, receiving water, or conveyance ditch to receiving water.
- On marine dock areas, sweep or vacuum rather than hose down debris. Collect any hose water generated and convey to appropriate treatment and disposal.
- Use a storm drain cover, filter fabric, or similarly effective runoff control device if dust, grit, washwater, or other pollutants may escape the work area and enter a catch basin. The containment device(s) must be in place at the beginning of the workday. Collect contaminated runoff and solids and properly dispose of such wastes before removing the containment device(s) at the end of the workday.

- Use a ground cloth, pail, drum, drip pan, tarpaulin, or other protective device (e.g. plastic wading pool) for activities such as paint mixing and tool cleaning outside or where spills can contaminate stormwater.
- Properly dispose of all wastes and prevent all uncontrolled releases to the air, ground, or water.
- Clean brushes and tools covered with non-water-based paints, finishes, or other materials in a manner that allows collection of used solvents (e.g., paint thinner, turpentine, xylol, etc.) for recycling or proper disposal.
- Store toxic materials under cover (tarp, etc.) during precipitation events and when not in use to prevent contact with stormwater.
- Enclose and/or contain all work while using a spray gun or conducting sand blasting and in compliance with applicable air pollution control, OSHA, and WISHA requirements. Do not conduct outside spraying, grit blasting, or sanding activities during windy conditions which render containment ineffective.
- Clean paintbrushes and tools covered with water-based paints in sinks connected to sanitary sewers or in portable containers that can be dumped into a sanitary sewer drain.

#### **4.4.7.3 Recommended BMPs**

- Recycle paint, paint thinner, solvents, pressure washer water, and any other recyclable materials.
- Use efficient spray equipment such as electrostatic, air-atomized, high volume/low pressure, or gravity feed spray equipment.
- Purchase recycled paints, paint thinner, solvents, and other products if feasible.

### **4.4.8 BMP A308: Commercial Printing Operations**

#### **4.4.8.1 Description of Pollutant Sources**

Materials used in the printing process include inorganic and organic acids, resins, solvents, polyester film, developers, alcohol, vinyl lacquer, dyes, acetates, and polymers. Waste products may include waste inks and ink sludge, resins, photographic chemicals, solvents, acid and alkaline solutions, chlorides, chromium, zinc, lead, spent formaldehyde, silver, plasticizers, and used lubricating oils. As the printing operations are conducted indoors, the only likely points of potential contact with stormwater are the outside temporary waste material storage area and area where chemicals are offloaded at external unloading bays. Pollutants can include TSS, pH, heavy metals, oil and grease, and COD.

#### **4.4.8.2 Required BMPs**

- Discharge process wastewaters to a sanitary sewer (if approved by the City of Tacoma) or to an approved process wastewater treatment system. Contact the City of Tacoma Source Control Unit at 253-591-5588 for discharge requirements.
- Do not discharge process wastes or wastewaters into storm drains or surface water.
- Determine whether any of these wastes qualify for regulation as dangerous wastes and dispose of them accordingly.
- Store raw materials or waste materials that could contaminate stormwater in covered and contained areas.
- Train all employees in pollution prevention, spill response, spill reporting, and environmentally acceptable materials handling procedures.

- Store materials in proper, appropriately labeled containers. Identify and label all chemical substances.

#### **4.4.8.3 Recommended BMPs**

- Wash printing press without solvents if feasible. If solvent cleaning is required use a solvent with a low VOC content. Don't evaporate ink cleanup trays to the outside atmosphere.
- Place cleanup sludges into a properly labeled container with a tight lid, designate the sludge, and dispose properly. It is the responsibility of the generator to designate waste as hazardous waste and provide supporting information.

For additional information on pollution prevention the following Washington Department of Ecology publications are recommended: [A Guide for Screen Printers](#), Publication #94-137 and [A Guide for Lithographic Printers](#), Publication #94-139.

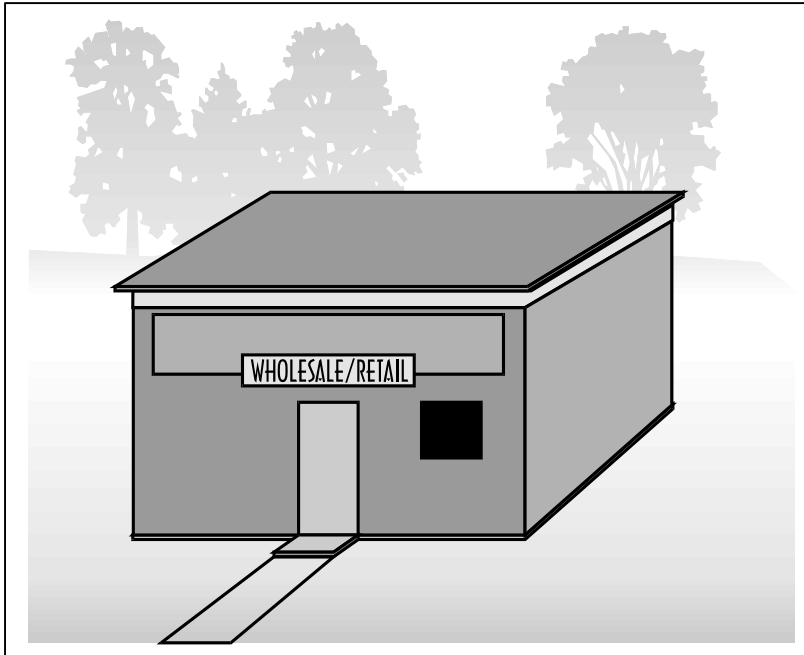
### **4.4.9 BMP A309: Manufacturing Operations – Outside**

#### **4.4.9.1 Description of Pollutant Sources**

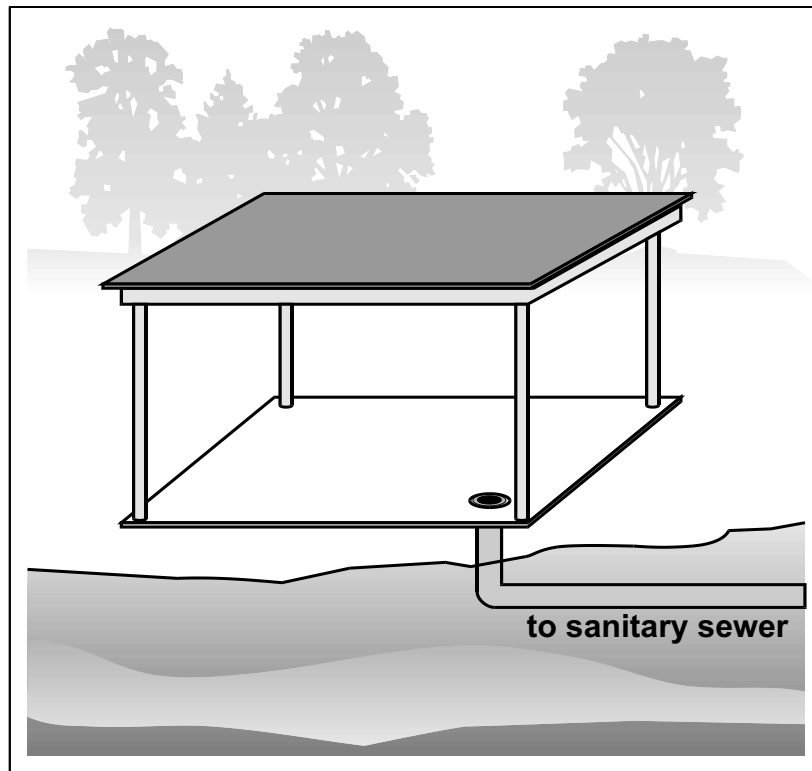
Manufacturing pollutant sources include outside process areas, stack emissions, and areas where manufacturing activity has taken place in the past and significant pollutant materials remain and are exposed to stormwater.

#### **4.4.9.2 Required BMPs**

- Sweep paved areas regularly, as needed, to prevent contamination of stormwater. Vacuum sweeping is preferred.
- Alter the activity by eliminating or minimizing the contamination of stormwater.
- Enclose the activity (see Figure 4 - 5). If possible, enclose the manufacturing activity in a building.
- Cover the activity and connect floor drains to a sanitary sewer, if approved by the City of Tacoma. Berm or slope the floor as needed to prevent drainage of pollutants to outside areas (see Figure 4 - 6).
- Isolate and segregate pollutants, as feasible. Convey the segregated pollutants to a sanitary sewer, process treatment, or dead-end sump, depending on available methods and applicable permit requirements.



**Figure 4 - 5. Enclose the Activity**



**Figure 4 - 6. Cover the Activity**

## 4.5 Storage and Stockpiling Activities

### 4.5.1 BMP A401: Storage or Transfer (Outside) of Solid Raw Materials, By-Products or Finished Products

#### 4.5.1.1 Description of Pollutant Sources

Solid raw materials, by-products, or products such as gravel, sand, salts, topsoil, compost, logs, sawdust, wood chips, lumber and other building materials, concrete, and metal products are typically stored outside in large piles, stacks, etc. at commercial or industrial establishments. Contact of outside bulk materials with stormwater can cause leachate and/or erosion of the stored materials. Contaminants may include TSS, BOD, organics, and dissolved salts (sodium, calcium, magnesium chloride, etc).

#### 4.5.1.2 Required BMPs

- Do not hose down the contained stockpile area to a storm drain or other conveyance leading to a storm drain or receiving water.
- Choose one or more of the source control BMP options listed below for stockpiles greater than 5 cubic yards of erodible or water soluble materials such as soil, road deicing salts, compost, unwashed sand and gravel, sawdust, etc. or for outside storage areas for solid materials such as logs, bark, lumber, metal products, etc.:

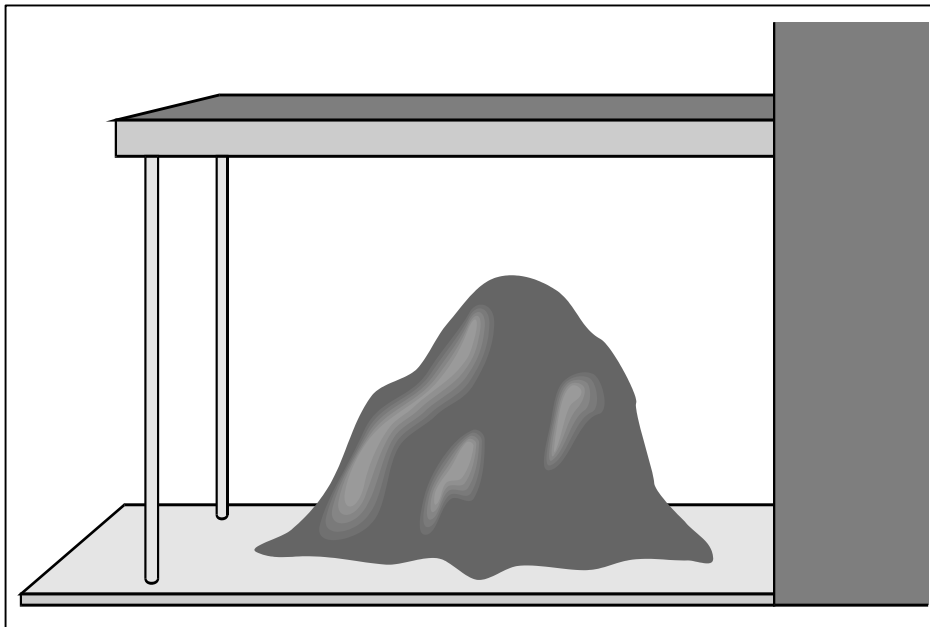
- Store in a building or paved and bermed covered area as shown in Figure 4 - 7.
- Place temporary plastic sheeting (polyethylene, polypropylene, hypalon, or equivalent) over the material.

OR

- Pave the area and install a stormwater drainage system. Place curbs or berms along the perimeter of the area to prevent the run-on of uncontaminated stormwater and to collect and convey runoff to treatment. Slope the paved area in a manner that minimizes contact between stormwater (e.g., pooling) and leachable materials in compost, logs, bark, wood chips, etc.
- For large stockpiles that cannot be covered, implement containment practices at the perimeter of the site and at any catch basins as needed to prevent erosion and discharge of the stockpiled material offsite or to a storm drain. Ensure that contaminated stormwater is not discharged directly to catch basins without being conveyed through a treatment BMP. For log yards see Ecology publication, "Industrial Stormwater General Permit Implementation Manual for Log Yards:", publication # 04-10-031.
- Convey contaminated stormwater from the stockpile area to a stormwater treatment device as required by this manual or other permit.
- Sweep areas that show accumulation of materials. Vacuum sweeping is also an acceptable method of removing accumulated material.

### 4.5.1.3 Recommended BMPs

- Maintain drainage areas in and around storage of solid materials with a minimum slope of 1.5 percent to prevent pooling and minimize leachate formation. Areas should be sloped to drain stormwater to the perimeter where it can be collected, or to internal drainage “alleyways” where material is not stockpiled.
- If and when feasible, collect and recycle water-soluble materials (leachates) to the stockpile.
- Stock cleanup materials such as brooms, dustpans, and vacuum sweepers near the storage area.



*Figure 4 - 7. Covered Storage Area for Bulk Solids (including berm if needed)*

## 4.5.2 BMP A402: Storage and Treatment of Contaminated Soils

### 4.5.2.1 Description of Pollutant Sources

This activity applies to businesses and agencies that store and treat soils contaminated with toxic organic compounds, petroleum products, or heavy metals. Stormwater runoff that comes in contact with contaminated soil can carry those contaminants along with loose dirt into receiving waters.

### 4.5.2.2 Required BMPs

Permits may be required by the Washington State Department of Ecology, Environmental Protection Agency, Tacoma/Pierce County Health Department, Puget Sound Clean Air Agency, and/or City of Tacoma Source Control depending on the nature of the project. The applicant is responsible for determining if permits are required from additional agencies. Contact each agency to determine their permitting requirements.

The BMPs included here are intended as a supplement to other regulations. The following BMPs or equivalent measures are required of all businesses engaged in storage and treatment of contaminated soils:

- The storage area for contaminated soils must be enclosed indoors, covered, or contained by a curb, dike, or berm constructed around the material storage area. If the contaminated soils are covered, stormwater run-on protection must also be provided. BMP S107 provides further details on containment and run-on prevention.
- Employees must be educated on methods to prevent contamination from leaving the site.
- Cleanup materials must be stocked near the storage area.
- Gutters, storm drains, catch basins, and other drainage system features on the site must be cleaned following the completion of site work, or at least once per year, whichever comes first. Sediments from such cleaning must be disposed of properly. See BMP S109 and S102 for details on catch basin cleaning and disposal options.

#### **4.5.2.3 Recommended BMPs**

The following BMPs are not required but can provide additional pollution protection:

- If feasible, the storage area should be swept weekly for collection of stray soil, which can be added back to the piles or properly disposed. See BMP S102 for information on disposal options.
- Implement an appropriate stormwater treatment BMP per Volume 5.

The use of any treatment BMP must not result in the violation of groundwater, surface water, wastewater, or drinking water quality standards.

### **4.5.3 BMP A403: Temporary Storage or Processing of Fruits or Vegetables**

#### **4.5.3.1 Description of Pollutant Sources**

This activity applies to businesses that temporarily store fruits and vegetables outdoors prior to processing or sale, or that crush, cut, or shred fruits or vegetables for wines, frozen juices, and other food and beverage products. These businesses may include farmers markets, fruit and vegetable stands, and fruit and vegetable processors. Nutrients and soil washing off of fruit and vegetables can have a detrimental effect on receiving waters.

Pollutants of concern include nutrients, suspended solids, biochemical oxygen demand (BOD), and color.

#### **4.5.3.2 Required BMPs**

Businesses that store or process fruits and vegetables are required to be covered under an Individual NPDES Permit and may require an Industrial Wastewater Discharge Permit from the City of Tacoma. Contact the Washington State Department of Ecology for information on BMPs related to fruit and vegetable processing and storing. Additional permitting may be required from the Tacoma/Pierce County Health Department.



## **4.5.4 BMP A404: Storage of Solid Wastes and Food Wastes**

### **4.5.4.1 Description of Pollutant Sources**

This activity applies to facilities such as hospitals, restaurants, meat and seafood markets, veterinarian clinics, schools, grocery stores, assisted living centers, and group assembly halls that store solid wastes and food wastes outdoors. This includes ordinary garbage. If improperly stored, these wastes can contribute a variety of pollutants to stormwater. For more information, call the Solid Waste Section at 253-541-5543.

Certain Food Service establishments are required to obtain a permit from the Tacoma/Pierce County Health Department, which may include inspection of the garbage facilities. Call the Pierce County Waste Management Section at 253-798-6047 for additional information.

**NOTE:** Dangerous solid wastes must be stored and handled under special guidelines. Businesses and agencies that store dangerous wastes must follow specific regulations outlined by the Department of Ecology and, in some cases, the Tacoma-Pierce County Health Department (TPCHD). Please contact the Department of Ecology at 360-407-6300 and the TPCHD at 253-798-6047 for the specific requirements and permitting information.

Pollutants of concern include toxic organic compounds, oils and greases, heavy metals, nutrients, suspended solids, chemical oxygen demand (COD), and biochemical oxygen demand (BOD).

### **4.5.4.2 Required BMPs**

The following BMPs are required of all businesses and public agencies engaged in storage of non-dangerous solid wastes or food wastes:

- All solid and food wastes must be stored in suitable containers. Piling of wastes without any cover is prohibited.
  - Waste storage areas and trash enclosures for food or liquid bearing wastes must be connected to the sanitary sewer and bermed or sloped to prevent stormwater run-on.
  - Trash compactors or dumpsters for food or liquid-bearing wastes shall drain to the sanitary sewer system and be designed as required by the City of Tacoma Source Control Department. Trash compactor hydraulic reservoirs or hoses shall be contained within the perimeter of the drainage pad.
  - Storage containers and compactors must be checked for leaks and broken seals and replaced if they are leaking, corroded, or otherwise deteriorating. If storage containers contain liquid wastes of any kind, then the container shall be located on a pad equipped with a drainage system connected to the City sanitary sewer.
  - A minimum of three feet of clearance must be maintained between a trash compactor or dumpster and any other storage containers kept in the storage area or trash enclosure. Alternatively, these storage containers can be kept in separate enclosures.
  - Storage containers must have leak-proof lids or be covered by some other means. Lids must be kept closed at all times. This is especially important for dumpsters, as birds can pick out garbage and drop it, promoting rodent, health, and stormwater problems.
- OR
- If lids cannot be provided for the waste containers, or they cannot otherwise be covered, a designated waste storage area must be provided with a containment berm, dike, or

curb, and the designated area must drain to a sanitary sewer or holding tank for further treatment. See BMP S107 and S103 for more information.

- Do not completely fill containers of waste fats, oil and grease. Leave a minimum of four inches of freeboard to prevent spills when the containers are moved or handled for recycling.
- Employees must be trained to frequently check storage containers for leaks and to ensure that the lids are on tightly.
- The waste storage area must be swept or otherwise cleaned frequently to collect all loose solids for proper disposal in a storage container. Do not hose the area to collect or clean solids. All solids must be swept and properly disposed of before hosing area.
- If containers are cleaned, all rinse water from cleaning must be disposed of in a sanitary sewer or septic system.
- Inspect regularly and clean out catch basins on the property that receive drainage from waste storage area. See BMP S109 for details on catch basin cleaning.
- Store containers such that wind will not be able to knock them over.

#### **4.5.4.3 Recommended BMPs**

The following BMPs are not required, but can provide additional pollution protection:

- Provide a backup storage container if the amount of waste accumulated appears to frequently exceed the capacity of the storage container.
- Locate drain to sanitary sewer at one end or side of the enclosure to ease cleaning the drain.
- In enclosures with drains to the sanitary sewer, provide an area for washing floor mats.
- Designate a storage area, pave the area, and slope the drainage to a holding tank or sanitary sewer drain. If a holding tank is used, the contents must be pumped out before the tank is full and properly disposed. See BMP S102 for more information on disposal options.
- Compost appropriate wastes. Contact City of Tacoma Solid Waste at 253-591-5543 for more information on composting.
- Recycle solid wastes. Contact City of Tacoma Solid Waste. at 253-591-5543 for more information.

### **4.5.5 BMP A405: Farmer's Markets**

#### **4.5.5.1 Description of Pollutant Sources**

Potential sources of pollutants include food waste, oil and grease, water that has come into contact with food, waste from equipment washing, and other typical garbage items. Examples of waste sources include: ice and water that has come into contact with food (either in produce washing or temperature regulation), cooking equipment washwater, and hand washing centers.

#### **4.5.5.2 Required BMPs**

- Dispose of wastewater into the sanitary sewer system. Wastewater shall not be disposed in the stormwater system. Either transport wastewater back to regular place of business for proper disposal, at the disposal site approved by the Tacoma/Pierce County Health Department as part of the food handling permit, or at the event's designated wastewater disposal sink.

- Fats, grease and oils shall not be disposed in the stormwater or sanitary system. Recycle cooking oils or secure for proper disposal.
- Clean flower water may be disposed into nearby grassy areas. Do not dispose of flower water directly into stormwater drains.
- Food carts and mobile food vendors must obtain and follow the requirements of a mobile food vendor permit as issued by the Tacoma/Pierce County Health Department.

#### **4.5.6 BMP A406: Recyclers and Scrap Yards**

##### **4.5.6.1 Description of Pollutant Sources**

Includes businesses that reclaim various materials for resale or for scrap, such as vehicles and vehicle/ equipment parts, construction materials, metals, computers, appliances, beverage containers, and papers.

Potential sources of pollutants include paper, plastic, metal scrap debris, engines, transmissions, radiators, batteries, and other materials that contain fluids or are contaminated with fluids. Other pollutant sources include leachate from metal components, contaminated soil, and the erosion of soil. Activities that can generate pollutants include the transfer, dismantling, and crushing of vehicles and scrap metal; the transfer and removal of fluids; maintenance and cleaning of vehicles, parts, and equipment; and storage of fluids, parts for resale, solid wastes, scrap parts, and materials, equipment and vehicles that contain fluids, generally in uncovered areas.

Potential pollutants typically found at vehicle recycle and scrap yards include oil and grease, ethylene and propylene glycol, total suspended solids, BOD, heavy metals, and acidic pH.

##### **4.5.6.2 Required BMPs**

For facilities subject to Ecology's Industrial Stormwater General Permit refer to BMP Guidance Document #94-146, "Vehicle Recyclers: A Guide to Implementing the Industrial Stormwater General National Pollutant Discharge Elimination System (NPDES) Permit Requirements", Washington Department of Ecology, January 2006 for selection of BMPs. The BMPs in that guidance document can also be applied to scrap material recycling facilities (depending on the pollutant sources existing at those facilities) and to non-permitted facilities.

Contact the City of Tacoma Source Control Unit at 253-591-5588 if contact stormwater or process wastewater is to be discharged from your site.

#### **4.5.7 BMP A407: Treatment, Storage or Disposal of Dangerous Wastes**

This activity applies to businesses and public agencies that are permitted by the Washington State Department of Ecology (DOE) to treat, store, or dispose of dangerous wastes. DOE regulates these facilities with specific requirements, which include the need for a National Pollutant Discharge Elimination System (NPDES) permit. Detailed BMPs are not included in this manual since site requirements for these facilities are well beyond the level of typical BMP applications.

Contact the City of Tacoma Source Control Unit at 253-591-5588 for their requirements. An Industrial Wastewater Discharge Permit is required before discharging contact stormwater or process wastewater to the City sanitary sewer system. The Tacoma-Pierce County Health Department also administers some aspects of dangerous waste treatment, storage, and disposal. Call 253-798-6047 for more information.

## **4.5.8 BMP A408: Storage of Liquid, Food Waste or Dangerous Waste Containers**

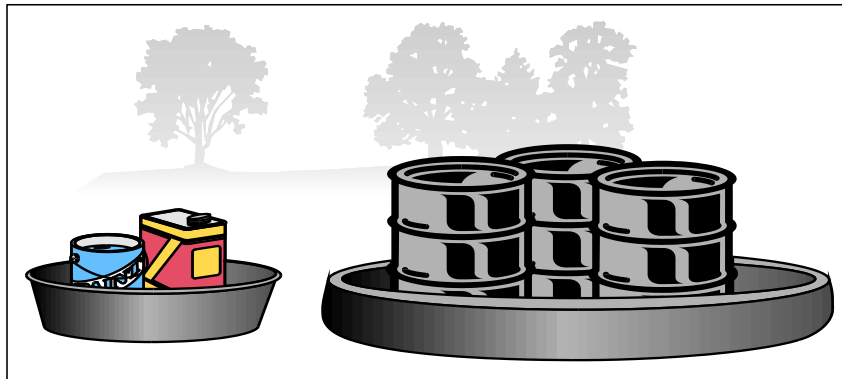
### **4.5.8.1 Description of Pollutant Sources**

Steel and plastic drums with volumetric capacities of 55 gallons or less are typically used at industrial facilities for storage of liquids and powders. The BMPs specified below apply to container(s) located outside a building used for temporary storage of accumulated food wastes, vegetable or animal grease, used oil, liquid feedstock cleaning chemicals, or Dangerous Wastes (liquid or solid), unless the business is permitted by Ecology to store the wastes. Leaks and spills of pollutant materials during handling and storage are the primary sources of pollutants. Oil and grease, acid/alkali pH, BOD, and metals are potential pollutant constituents.

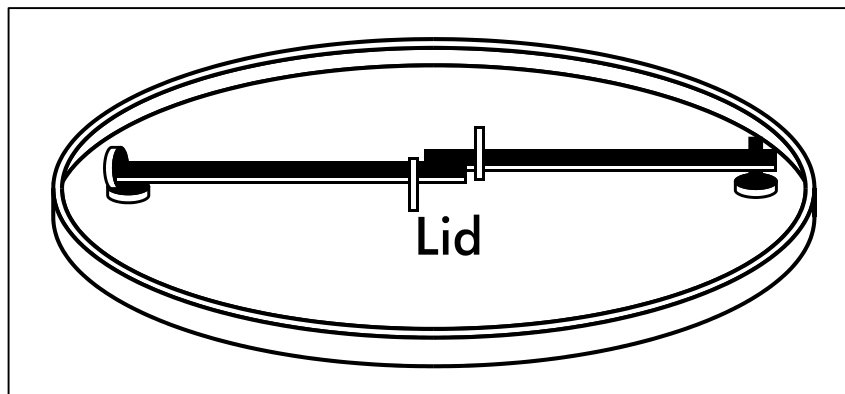
### **4.5.8.2 Required BMPs**

- Place tight-fitting lids on all containers. Provide adequate freeboard/headspace.
- Place drip pans beneath all mounted container taps and at all potential drip and spill locations during filling and unloading of containers.
- Inspect container storage areas regularly for corrosion, structural failure, spills, leaks, overfills, and failure of piping systems. Check containers daily for leaks/spills. Replace containers, secure lids, and replace and tighten bungs in drums, as needed.
- Drums stored in an area where unauthorized persons may gain access must be secured in a manner that prevents accidental spillage, pilferage, or any unauthorized use (see Figure 4 - 9).
- If the material is a Dangerous Waste, the business owner must comply with any additional TPCHD or Ecology requirements. Please contact the Department of Ecology at 360-407-6300 and the TPCHD at 253-798-6047 for specific requirements and permitting information
- Storage of reactive, ignitable, or flammable liquids must comply with the Uniform Fire Code.
- Cover dumpsters or keep them under cover, such as a lean-to, to prevent the entry of stormwater. Replace or repair leaking garbage dumpsters.
- Drain dumpsters and/or dumpster pads to sanitary sewer. Keep dumpster lids closed. Install waterproof liners.
- Keep containers with Dangerous Waste, food waste or other potential pollutant liquids inside a building unless this is impracticable due to site constraints or Uniform Fire Code requirements.
- Store containers in a designated area that is covered, bermed, or diked; paved; and impervious in order to contain leaks and spills (see Figure 4 - 10). The secondary containment shall be sloped to drain into a dead-end sump for the collection of leaks and small spills.
- For liquid wastes, surround the containers with a dike as illustrated in Figure 4 - 10. The dike must be of sufficient height to provide a volume of either 10 percent of the total enclosed container volume or 110 percent of the volume contained in the largest container, whichever is greater, or, if a single container, 110 percent of the volume of that container.

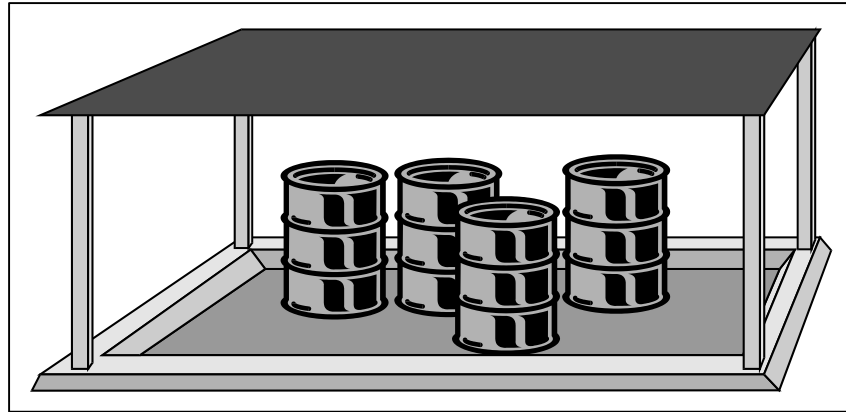
- Where material is temporarily stored in drums, a containment system can be used, as illustrated, in lieu of the above system (see Figure 4 - 8).
- Place containers mounted for direct removal of a liquid chemical for use by employees inside a containment area as described above. Use a drip pan during liquid transfer (see Figure 4 - 11).
- For stormwater in a containment area, the containment area shall contain a sumped outlet. The sump outlet must be a lockable steel line of a diameter sufficient to handle the contained water. Before the valve is opened, the stormwater must be evaluated to determine if it must go to treatment or can be discharged without treatment. If the stormwater is contaminated, direct the sump outlet of the containment area to a stormwater treatment system appropriate for the products contained, or to sanitary sewer system. Discharges must not be directed toward sensitive areas, foundations, sidewalks, traffic or the City right-of-way.
- Another option for discharge of contaminated stormwater is to provide a dead-end sump or catchment. Stormwater can then be pumped to a tank truck or other appropriate vehicle for off-site treatment and/or disposal.
- If a storage area is to be used on-site for less than 30 days, a portable temporary secondary system as shown in Figure 4 - 8 can be used.



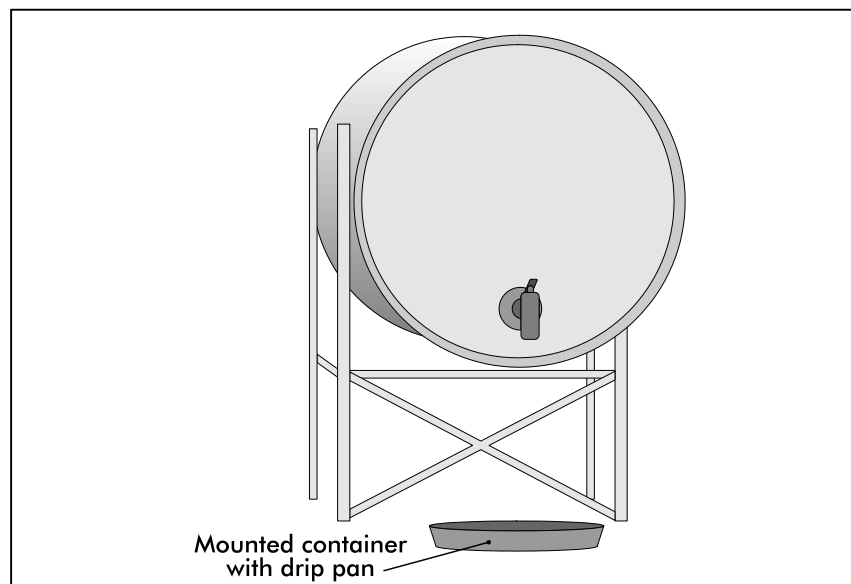
**Figure 4 - 8. Secondary Containment Vessel**



**Figure 4 - 9. Locking System for Drum Lid**



**Figure 4 - 10. Covered and Bermed Containment Area**



**Figure 4 - 11. Mounted Container**

## **4.5.9 BMP A409: Storage of Liquids in Above-Ground Tanks**

### **4.5.9.1 Description of Pollutant Sources**

Above-ground tanks containing liquids (excluding uncontaminated water) may be equipped with a valved drain, vent, pump, and bottom hose connection. These tanks are commonly associated with chemical and petroleum facilities and standby generators (see Figure 4 - 13 and Figure 4 - 14). These tanks may be heated with steam heat exchangers equipped with steam traps. Leaks and spills can occur at connections and during liquid transfer. Oil and grease, organics, acids, alkalis, and heavy metals in tank water and condensate drainage can also cause stormwater contamination at storage tanks.

### **4.5.9.2 Required BMPs for All Tanks**

- Install secondary containment or a double-walled tank.

- For stormwater in a containment area, the containment area shall contain a sumped outlet. The sump outlet must be a lockable steel line of a diameter sufficient to handle the contained water. Before the valve is opened, the stormwater must be evaluated to determine if it must go to treatment or can be discharged without treatment. If the stormwater is contaminated, direct the sump outlet of the containment area to a stormwater treatment system appropriate for the products contained, or to a sanitary sewer system. Discharges must not be directed toward sensitive areas, foundations, sidewalks, traffic, or the City right-of-way.
- Inspect the tank containment areas regularly to identify leaks/spills, cracks, corrosion, etc. in problem components such as fittings, pipe connections, and valves.
- Develop a spill plan as per the requirements of BMP A714: Spills of Oil and Hazardous Substances.
- Place adequately sized drip pans beneath all mounted taps and drip/spill locations during filling/unloading of tanks. Valved drain tubing may be needed in mounted drip pans.
- Sweep and clean the tank storage area regularly, if paved.
- Replace or repair tanks or other components that are leaking, corroded, or otherwise deteriorating.
- All installations shall comply with the International Fire Code and the National Electric Code.
- Locate permanent tanks in impervious (Portland cement concrete or equivalent) secondary containment surrounded by dikes as illustrated in Figure 4 - 12 and Figure 4 - 13, or use UL approved double-walled tanks.
- Tanks with exposure to traffic must be protected with bollards, jersey barriers, or walls. Bollards should be at least 4 feet high, at least 3 feet from the tank, and no more than 4 feet apart. It is recommended that bollards are painted yellow for ease of visibility.
- Include a tank overfill protection system to minimize the risk of spillage during loading.
- There must be at least 5 feet of space between the tanks and any enclosures.
- Tank water and condensate discharges are process wastewater that may need an NPDES Permit or approval from the City of Tacoma Source Control to discharge to the sanitary system.

#### **4.5.9.3 Required BMPs for Single-walled Tanks**

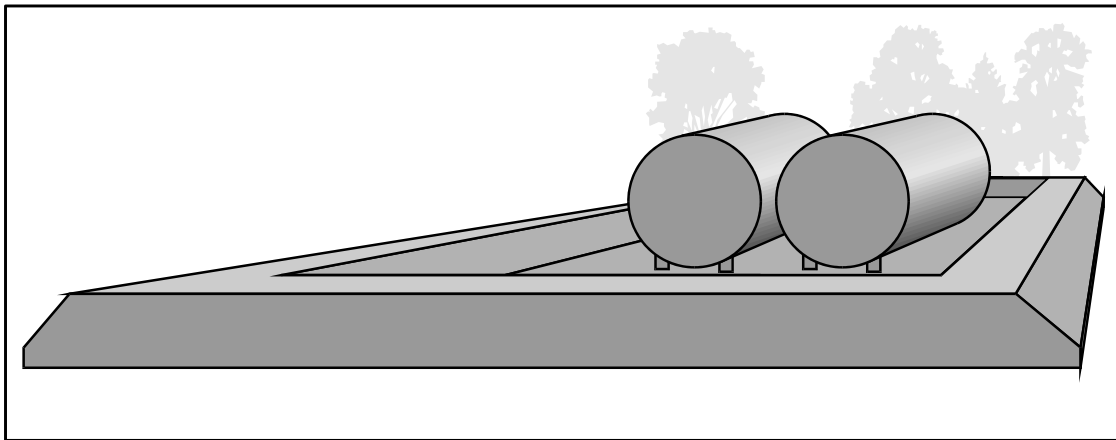
- The containment volume shall be 100% of the volume of the largest tank plus the volume of stormwater from rain events up to a 25-year, 24-hour storm within the containment area or 110% of the volume of the largest tank, whichever is greater.
- There must be at least 5 feet of space between the tanks and any enclosures.
- Slope the secondary containment to drain to a dead-end sump (optional), or equivalent, for the collection of small spills.
- If the tank containment area is uncovered, equip the outlet from the spill-containment sump with a shutoff valve, which is normally closed and locked. Valves for flammables containment shall be made of steel. Valves for corrosives containment shall be compatible with the material being stored.
- The external valve may be opened manually only to convey contaminated stormwater to an approved treatment or disposal facility, or to convey uncontaminated stormwater to a storm drain. Evidence of contamination can include the presence of visible sheen, color, or turbidity in the runoff, or existing or historical operational problems at the facility.

Simple pH measurements with litmus or pH paper can be used for areas subject to acid or alkaline contamination.

- At petroleum tank farms, convey stormwater contaminated with floating oil or debris in the contained area through an API or CP-type oil/water separator (Volume 5, Treatment BMPs) or other approved treatment facility prior to discharge to storm drain or surface water. Direct discharges may require additional permits from Department of Ecology or other agencies within jurisdictions.
- Loading racks and transfer areas associated with tank farms shall provide spill containment and treatment sized to encompass the largest vessel (trailer, railcar, intermodal tank) using the area.

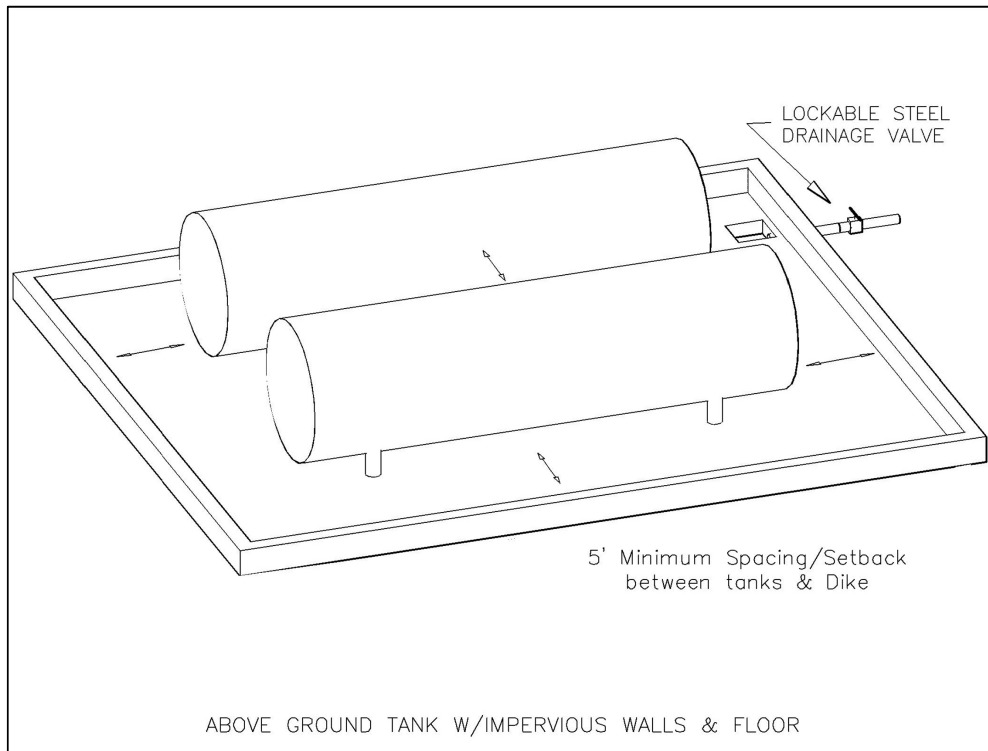
#### **4.5.9.4 Required BMPs for Double-walled Tanks**

- Tank pads and the fuel delivery area should be protected from stormwater run-on and sized and sloped to capture any leaks or spills from the tank or fueling process.
- Feed and return lines from the tanks shall be doubled walled or entirely contained within the utility corridor.
- Catch basins receiving drainage from the tank pad and fueling area should be oversized and have downturned elbows in their outlets or flow to an appropriately sized oil/water separator.
- This section does not apply to temporary job-site fuel tanks. See Volume 2 for BMPs concerning spill management at construction sites.

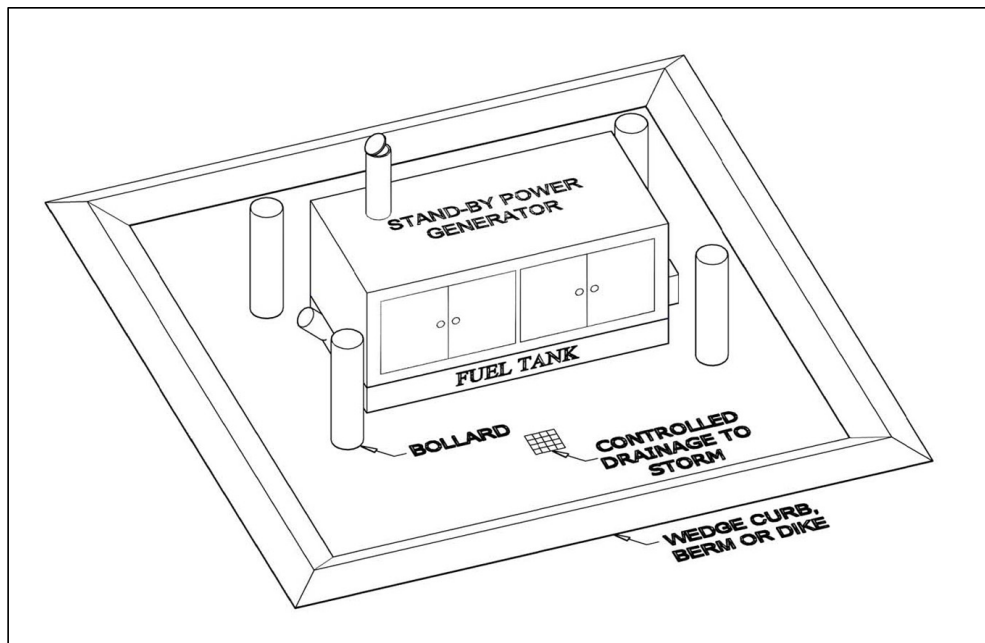


**Figure 4 - 12. Above-Ground Tank Storage**





**Figure 4 - 13. Above-Ground Tank with Impervious Walls and Floor**



**Figure 4 - 14. Standby Generator**

## **4.5.10 BMP A410: Parking and Storage for Vehicles and Equipment**

### **4.5.10.1 Description of Pollutant Sources**

Parked vehicles at public and commercial parking lots and garages, such as retail stores, fleet vehicle (including rent-a-car lots and car dealerships), equipment sale and rental parking lots, and parking lot driveways, can be sources of toxic hydrocarbons and other organic compounds, oils and greases, metals, and suspended solids.

### **4.5.10.2 Required BMPs**

- If washing of a parking lot is conducted, discharge the washwater to a sanitary sewer (if allowed by the City of Tacoma) or other approved wastewater treatment system, or collect it for off-site disposal.
- Do not hose down the area to a storm drain or receiving water. Sweep (vacuum sweeping is preferred) parking lots, storage areas, and driveways regularly to collect dirt, waste, and debris.
- An oil removal system such as an API or CP oil and water separator, catch basin filter, or equivalent BMP (see Volume 5), approved by the City of Tacoma, is applicable for parking lots meeting the threshold vehicle traffic intensity level of a high-use site. For more information on high-use sites, refer to Volume 5, Chapter 1.
- Covered floors of parking garages with drains must drain to the sanitary sewer through an approved oil/water separator. Uncovered floors must be routed to the storm drainage system through an approved treatment device.

## **4.6 Construction and Demolition Activities**

### **4.6.1 BMP A501: Clearing, Grading and Preparation of Construction Sites**

This activity applies to businesses and municipal agencies that develop lands for construction. It also applies to residences that undertake large yard clearing and grading projects. Stormwater runoff from bare ground can be loaded with dirt and other pollutants. This material can clog ditches and stream channels, thus reducing carrying capacity and increasing flooding, as well as smothering spawning beds for fish. Simply controlling runoff and not allowing it to leave the site will prevent these harmful effects. Clearing, grading, and preparation activities are covered in detail in Volume 2 of this manual, Construction Stormwater Pollution Prevention. Grading activities are also regulated in the City of Tacoma by the Grading and Excavation Code, Section 2.02.330 TMC.

Control of stormwater run-on and soil stabilization is critical. Limiting the area to be cleared and graded during wet weather seasons will make site stabilization and sediment control easier.

Coverage under Ecology's Construction Stormwater General Permit is required for construction sites that result in the disturbance of one acre or more of land. Compliance with the Construction Stormwater Pollution Prevention requirements in Ecology's manual is required, as applicable.

### **4.6.2 BMP A502: Demolition of Buildings**

#### **4.6.2.1 Description of Pollutant Sources**

This activity applies to removal of existing buildings by controlled explosions, wrecking balls, or manual methods, and subsequent clearing of the rubble. The loose debris can contaminate stormwater. Pollutants of concern include toxic organic compounds, heavy metals, asbestos, and suspended solids.

#### **4.6.2.2 Required BMPs**

The following BMPs or equivalent measures are required of all businesses and public agencies engaged in building demolition:

- Identify and properly abandon all utility connections such as sanitary sewer, gas, fuel lines and tanks.
- If directed to keep water out of the storm system during demolition activity, storm drain covers or a similarly effective containment device must be placed on all nearby drains to prevent dirty runoff and loose particles from entering the storm drainage system. If storm drains are not present, dikes, berms, or other methods must be used to protect overland discharge paths from runoff. See BMP S102 and S107 for more information on runoff control and disposal options.
- Utilize storm drain inlet protection per Volume 2, "BMP C220: Storm Drain Inlet Protection" on page 105.
- Street gutters, sidewalks, driveways, and other paved surfaces in the immediate area of the demolition must be swept at the end of each work day to collect and properly dispose of loose debris and garbage.
- Sweep areas that show accumulation of materials. Vacuum sweeping is also an acceptable method of removing accumulated material.

### **4.6.2.3 Recommended BMPs**

The following BMPs are not required, but can provide additional pollution protection:

- Use dust control methods as described in Volume 2, “BMP C140: Dust Control ” on page 65 and/or per this volume section 4.7.1 BMP A601: Dust Control at Disturbed Land Areas and Unpaved Roads and Parking Lots.
- If possible, a wall should be constructed to prevent stray building materials and dust from escaping the area during demolition.
- Schedule demolition to take place at a dry time of the year.

## **4.6.3 BMP A503: Building, Repair, Remodeling and Construction**

### **4.6.3.1 Description of Pollutant Sources**

This activity refers to activities associated with construction of buildings and other structures, remodeling of existing buildings and houses, and general exterior building repair work. Washing of buildings is covered under Volume 4, Section 4.2.3. Painting of buildings is covered under A307 Painting, Finishing, and Coating of Vehicles, Boats, Buildings, and Equipment. Concrete pouring is covered under A302 Concrete Pouring and Asphalt Application at Temporary Sites.

Pollutants of concern include toxic organics, suspended solids, heavy metals, asbestos, pH, oils, PCBs and greases.

### **4.6.3.2 Required BMPs**

The following BMPs or equivalent measures are required of all businesses engaged in building repair, remodeling, and construction:

- Employees must be educated about the need to control site activities to prevent stormwater pollution, and also must be trained in spill cleanup procedures.
- Spill cleanup materials, appropriate to the chemicals being used on site, must be available at the work site at all times.
- The work site must be cleaned up at the end of each work day, with materials such as solvents put away indoors or covered and secured so that vandals will not have access to them.
- The area must be swept daily to collect loose litter, paint chips, grit, and dirt.
- Absolutely no substance can be dumped on pavement, the ground, or in or toward storm drains, regardless of its content, unless it is only uncontaminated water.
- Bermed ground or drop cloths must be used underneath scraping and sandblasting work. Ground cloths, buckets, or tubs must also be used anywhere that work materials are laid down.
- Tools covered with non-water-based finishes or other materials must be cleaned in a manner that enables collection of used solvents for recycling or proper disposal. See BMP S102 for disposal options.
- Inlet protection as described in Volume 2, BMP C220: Storm Drain Inlet Protection must be used if dust, grit, washwater, or other pollutants may escape the work area. This is particularly necessary on rainy days. Provide inlet protection of the storm drain at the beginning of the work day. Don't perform outdoor work during wet weather if contaminants could be washed off-site by rainfall.

### **4.6.3.3 Recommended BMPs**

The following BMPs are not required, but can provide additional pollution protection:

- Recycle materials whenever possible.
- Use dust control methods as described in Volume 2, BMP C140: Dust Control and/or per this volume section 4.7.1 BMP A601: Dust Control at Disturbed Land Areas and Unpaved Roads and Parking Lots.
- Activities such as tool cleaning should occur over a ground cloth or within a containment device such as a tub.

## **4.7 Dust Control, and Soil and Sediment Control**

### **4.7.1 BMP A601: Dust Control at Disturbed Land Areas and Unpaved Roadways and Parking Lots**

#### **4.7.1.1 Description of Pollutant Sources**

Dust can cause air and water pollution problems particularly at demolition sites, disturbed land areas, and unpaved roadways and parking lots.

#### **4.7.1.2 Required BMPs**

- Sprinkle or wet down soil or dust with water as long as it does not result in runoff or a wastewater discharge. Minimize the amount of water to avoid washing pollutants into the storm drainage system. At active construction sites, street sweeping shall be performed prior to washing the street.
- Use only local and/or state government approved dust suppressant chemicals such as those listed in Ecology Publication #96-433, "Techniques for Dust Prevention and Suppression." See BMP C127, Polyacrylamide for Soil Erosion Protection, in Volume 2, Chapter 3 of this manual.
- Avoid excessive and repeated applications of dust suppressant chemicals. Time the application of dust suppressants to avoid or minimize their wash-off by rainfall or human activity such as irrigation.
- Use stormwater containment to prevent the conveyance of solids by stormwater into storm drains or receiving waters.
- The use of motor oil or other oils for dust control is prohibited. Care shall be taken when using lignin derivatives and other high BOD chemicals in excavations or areas easily accessible to surface water or groundwater.
- Consult with the Ecology Southwest Regional Office at 360-407-6300 on discharge permit requirements if the dust suppression process results in a wastewater discharge to the ground, groundwater, storm drain, or surface water.

#### **4.7.1.3 Recommended BMPs for Roadways and Other Trafficked Areas**

- Consider limiting use of off-road recreational vehicles on dust generating land.
- Consider paving unpaved permanent roads, approaches, exits, access lanes, and other trafficked areas at municipal, commercial, and industrial areas.
- Consider paving or stabilizing shoulders of paved roads with gravel, vegetation, or City of Tacoma approved chemicals.
- Encourage use of alternate paved routes, if available.
- Vacuum or wet sweep fine dirt and skid control materials from paved roads soon after winter weather ends or as needed.
- Consider using traction sand that is pre-washed to reduce dust emissions.

#### **4.7.1.4 Recommended BMPs for Dust Generating Areas**

- Prepare a dust control plan. Helpful references include Fugitive Dust Background Document and Technical Information Document for Best Available Control Measures (EPA-450/2-92-004).
- Limit exposure of soil (dust source) as much as feasible.
- Stabilize dust-generating soil by growing and maintaining vegetation, mulching, topsoiling, and/or applying stone, sand, or gravel.
- Apply windbreaks in the soil such as trees, board fences, tarp curtains, bales of hay, etc.
- Cover dust-generating piles with wind-impervious fabric, or equivalent material.

Additional information on dust control can be found in Volume 2 of this manual.

#### **4.7.2 BMP A602: Dust Control at Manufacturing Sites**

##### **4.7.2.1 Description of Pollutant Sources**

Industrial material handling activities can generate considerable amounts of dust that is typically removed using exhaust systems. This can generate air emissions that can contaminate stormwater. Dusts can be generated at cement and concrete product mixing facilities, foundries, and wherever powdered materials are handled. Particulate materials that are of concern to air pollution control agencies include grain dust, sawdust, coal, gravel, crushed rock, cement, and boiler fly ash. The objective of this BMP is to reduce the stormwater pollutants caused by dust generation and control.

##### **4.7.2.2 Required BMPs**

- Clean building roofs, powder material handling equipment, and vehicles that can be sources of stormwater pollutants as needed to remove accumulated dust and residue.
- Regularly sweep dust accumulation areas that can contaminate stormwater. Sweeping shall be conducted using vacuum filter equipment to minimize dust generation and to ensure optimal dust removal.
- Minimize the amount of water used for dust control to avoid washing pollutants into the storm drainage system.

##### **4.7.2.3 Recommended BMPs**

- In manufacturing operations, train employees to carefully handle powders to prevent generation of dust.
- Use dust filtration/collection systems such as bag house filters, cyclone separators, etc. to control vented dust emissions that could contaminate stormwater. It may be necessary to monitor rooftops for possible accumulations of materials and take appropriate measures to prevent this material from entering the storm drainage system. Control of dust at foundries, metal shredders, stone and tile cutting facilities, and material transfer and handling facilities are some examples.
- Use approved dust suppressants such as those listed in Ecology Publication "Techniques for Dust Prevention and Suppression," #96-433. (Ecology, 2003). Application of some products may not be appropriate in close proximity to receiving waters or conveyances close to receiving waters. For more information check with the Ecology Southwest Regional Office or the City of Tacoma.
- Use water quality treatment BMPs as necessary. Refer to Volume 5 for information regarding water quality treatment BMPs.

- Additional information on dust control can be found in Volume 2 of this manual.

### **4.7.3 BMP A603: Soil Erosion and Sediment Control at Industrial Sites**

#### **4.7.3.1 Description of Pollutant Sources**

Industrial activities on soil areas, exposed and disturbed soils, steep grades, etc. can be sources of sediments that can contaminate stormwater runoff.

#### **4.7.3.2 Required BMPs**

Permanently stabilize areas not being worked. Apply temporary cover to areas not immediately being worked. Refer to Volume 2 for additional information concerning temporary erosion protection measures.



## 4.8 Other Activities

### 4.8.1 BMP A701: Commercial Animal Handling Areas

#### 4.8.1.1 Description of Pollutant Sources

Racetracks, kennels, fenced pens, veterinarians, and businesses that provide boarding services for horses, dogs, cats, etc. can generate pollutants from activities such as manure deposits, animal washing, grazing, and any other animal handling activity that could contaminate stormwater. Pollutants can include coliform bacteria, nutrients, total suspended solids, and animal-related pharmaceuticals. Kennels shall be as defined in TMC 17.03.

#### 4.8.1.2 Required BMPs

- Regularly scoop, sweep and clean animal keeping areas to collect and properly dispose of droppings, uneaten food, and other potential stormwater contaminants.
- Do not hose down to storm drains or receiving waters those areas that contain potential stormwater contaminants.
- Contaminated water must go to the sanitary sewer. An animal fur/hair interceptor may be required.
- Do not allow any wash water to be discharged to storm drains or to receiving water. Wash water shall be conveyed to the sanitary sewer system.
- If animals are kept in unpaved and uncovered areas, the ground must either have vegetative cover or some other type of ground cover, such as mulch.
- If animals are not leashed or in cages, the area where animals are kept must be surrounded by a fence or other devices to prevent animals from moving away from the controlled area where BMPs are used.
- Uncovered outdoor runs shall not be connected to the sanitary sewer system unless approved by Environmental Services. No contaminated runoff may enter the storm drains.
- Unused pet pharmaceuticals shall not be discharged to the municipal sewer system. They shall be returned to the animal's owner or deposited to a drug take-back disposal facility. See <http://www.co.pierce.wa.us/?nid=1940> or <http://www.takebackyourmeds.org> for drop-off locations. See the City of Tacoma Medical Waste Sanitary Policy for additional information on medical waste disposal.

### 4.8.2 BMP A702: Log Sorting and Handling

#### 4.8.2.1 Description of Pollutant Sources

Log yards are paved or unpaved areas where logs are transferred, sorted, debarked, cut, and stored to prepare them for shipment or for the production of dimensional lumber, plywood, chips, poles, or other products. Log yards are generally maintained at sawmills, shipping ports, and pulp mills. Typical pollutants include oil and grease, BOD, settleable solids, total suspended solids (including soil), high and low pH, heavy metals, pesticides, wood-based debris, and leachate.

Truck traffic to and from these facilities can track sediment onto roadways. An aggressive sweeping program is recommended to ensure sediment does not reach the storm system.

The following are pollutant sources:

- Log storage, rollout, sorting, scaling, and cutting areas
- Log and liquid loading areas
- Log sprinkling
- Debarking, bark bin, and conveyor areas
- Bark, ash, sawdust and wood debris piles, and other solid wastes
- Metal salvage areas
- Truck, rail, ship, stacker, and loader access areas
- Log trucks, stackers, loaders, forklifts, and other heavy equipment
- Maintenance shops and parking areas
- Cleaning areas for vehicles, parts, and equipment
- Storage and handling areas for hydraulic oils, lubricants, fuels, paints, liquid wastes, and other liquid materials
- Pesticide usage for log preservation and surface protection
- Application of herbicides for weed control
- Contaminated soil resulting from leaks or spills of fluids

#### **4.8.2.2 Ecology's Baseline General Permit Requirements:**

Industries with log yards are required to obtain coverage under the baseline General Permit for Discharges of Stormwater Associated with Industrial Activities to Surface Water. The permit requires preparation and on-site retention of Stormwater Pollution Prevention Plans (SWPPP). The SWPPP must identify operational, source control, erosion and sediment control, and, if necessary, treatment BMPs. Required and recommended operational, source control, and treatment BMPs are presented in detail in Ecology's Guidance Document: Industrial Stormwater General Permit Implementation Manual for Log Yards, Publication # 04-10-031. It is recommended that all log yard facilities obtain a copy of this document.

### **4.8.3 BMP A703: Boat Building, Mooring, Maintenance and Repair**

#### **4.8.3.1 Description of Pollutant Sources**

Sources of pollutants at boat and ship building, repair, and maintenance facilities at boatyards, shipyards, ports, and marinas include pressure washing, surface preparation, paint removal, sanding, painting, engine maintenance and repairs, and material handling and storage, if conducted outdoors. Potential pollutants include spent abrasive grits, solvents, oils, ethylene glycol, washwater, paint over-spray, cleaners/detergents, paint chips, scrap metal, welding rods, resins, glass fibers, dust, and miscellaneous trash. Pollutant constituents include TSS, oil and grease, organics, copper, lead, tin, and zinc. Related activities are covered under the following activity headings in this manual, and other BMPs provided in this manual:

- |      |   |
|------|---|
| A103 | Washing, Pressure Washing, and Steam Cleaning of Vehicles/<br>Equipment/Building Structures |
| A202 | Fueling at Dedicated Stations   |

- A407 Storage of Liquid, Food Waste or Dangerous Waste Containers
- A714 Spills of Oil and Hazardous Substances

#### **4.8.3.2 Required BMPs**

The following BMPs or equivalent measures are required of all businesses, public agencies, and private boat owners engaged in boat building, mooring, maintenance and repair that are not covered by the NPDES permit for boatyards:

- Maintenance and repair activities that can be moved on-shore must be moved accordingly. This action reduces some of the potential for direct pollution impact on waterbodies.
- Blasting and spray painting activities must be sheltered by hanging tarps to block the wind and prevent dust and overspray from escaping. Move the activity indoors if possible. Contact the Puget Sound Clean Air Agency for details and limitations
- Bermed ground cloths must be used for collection of drips and spills in painting and finishing operations, and for paint chips and used blasting sand from sand blasting.
- Collect spent abrasives regularly and store under cover to await proper disposal.
- Dispose of greasy rags, oil filters, air filters, batteries, zinc anodes, spent coolant, and degreasers properly.
- Drain oil filters before disposal or recycling.
- Bilge water must be collected for proper disposal rather than discharged on land or water. See BMP S102 for detail on disposal options. Several companies are available for bilge pumpout services. Use oil-absorbent pads to capture the oil in the bilge water before or during pumping. If pads are used, they must be recycled or properly disposed.
- Ballast water that has an oily sheen on the surface must be collected for proper disposal rather than discharged on land or water. See BMP S102 for details on disposal options.
- Sewage from sanitary holding tanks on ships must be approved for discharge to the sanitary sewer. Contact the City of Tacoma Source Control Unit at 253-591-5588.
- Solid wastes from international vessels must be evaluated on a case-by-case basis. Contact the City of Tacoma Solid Waste Division at 253-591-5544 for assistance. Galley wastes may need to be taken to a United States Department of Agriculture Animal and Plant Health Inspection Service (APHIS) approved facility. For assistance, contact the local APHIS office during normal business hours at 206-553-2400 or 206-553-4406 after hours.
- Maintenance yard areas must be swept and cleaned, without hosing down the area, at least once per week or as needed. This prevents sandblasting materials, scrapings, paint chips, oils, and other loose debris from being carried away with stormwater. The collected materials must be disposed of properly. See BMP S102 for disposal options.
- Docks and boat ramps must be swept at least once per week or as needed, and the collected materials must be disposed of properly. Dry docks must be swept before flooding.
- Paint and solvent mixing, fuel mixing and similar handling of liquids shall be performed on shore, or such that no spillage can occur directly into surface waterbodies.
- Routine cleanup materials such as oil-absorbent pads, brooms, dustpans, shop vacuums, mops, buckets, and sponges must be stocked near docks.

- When washing a boat in the water, use no soaps or detergents. Brush the hull with water only.
- Comply with BMP A203 and A101 if engine repair and maintenance are conducted.
- In the event of an accidental discharge of oil or hazardous material into waters of the state or onto land with a potential for entry into state waters, immediately notify the yard, port, or marina owner or manager, the Department of Ecology, and the National Response Center at 1-800-424-8802 (24-hour). If the spill can reach or has reached marine waters, contact the U.S. Coast Guard at 206-217-6232.

#### **4.8.3.3 Recommended BMPs**

The following BMPs are not required but can provide additional pollution protection:

- Boat construction and structural repair activities should be covered.
- Materials such as paints, tools, and ground cloths should be stored indoors or in a covered area when not in use.
- Select the least toxic anti-fouling paint available.
- Boat interiors should be routinely cleaned, with proper disposal of collected materials, so that accumulations of water drained from the boat's interior are not contaminated.
- Use sanders that have dust containment bags or use vacuum sanders, and avoid sanding in windy conditions.
- All used oil should be recycled if feasible. Most marinas now offer used oil recycling services. To dispose of filters, let drain 24 hours, then double wrap in plastic and dispose in the regular garbage, or take them to the Tacoma Landfill Household Hazardous Waste facility for recycling. Pending state legislation may make disposal in the garbage illegal, so call the Hazardous Waste Line at 1-800-287-6429 for current information.
- Citizens for a Healthy Bay, a local environmental group, provides "Clean Bay Boating Kits." Call them at 253-383-2429 to obtain a free kit.
- Check with marinas for other BMPs they have developed.
- Use water quality treatment BMPs as necessary for the pollutants of concern. Refer to Volume 5 for information about water quality treatment BMPs.
- Check the Resource Manual for Pollution Prevention in Marinas, Publication # 98-11, May 1998 for additional information.
- Use clean, green boating practices. See <http://www.ecy.wa.gov/programs/wq/nonpoint/cleanboating/> for additional information.

#### **4.8.4 BMP A704: Logging**

##### **4.8.4.1 Description of Pollutant Sources**

This activity covers logging activities that fall under the Washington State Forest Practices Act category of Class IV general forest practices. These are situations where timber harvesting is done in the process of converting forest lands into other land uses, such as home and business construction. Stormwater runoff from bare ground can be loaded with dirt and other pollutants. This material can clog ditches and stream channels, thus reducing carrying capacity and increasing flooding, as well as smothering spawning beds for fish. Simply controlling runoff and not allowing it to leave the site will prevent these harmful effects. Clearing and grading activities are covered in detail in Volume 2 of this manual, Construction Stormwater Pollution Prevention.

Grading activities are also regulated in the City of Tacoma by the Grading and Excavation Code, Section 2.02.370 TMC.

Control of stormwater run-on and soil stabilization is critical. Limiting the area to be cleared and graded during wet weather seasons will make site stabilization and sediment control easier.

Coverage under Ecology's Construction Stormwater General Permit is required for construction sites that result in the disturbance of one acre or more of land. Compliance with the Construction Stormwater Pollution Prevention requirements in Ecology's manual is required, as applicable. Virtually all logging operations will require a permit from the Washington State Department of Natural Resources. Sensitive/critical areas and wetlands ordinances for Tacoma also contain requirements for logging activities in the vicinity of waterbodies.

Pollutants of concern include suspended solids, oils and greases, biochemical oxygen demand (BOD), nutrients, toxic organic compounds, and heavy metals.

#### **4.8.4.2 Required BMPs**

- Vegetation along stream corridors, and adjacent to other waterbodies and wetlands, must be preserved. Maintenance of a vegetated buffer enables filtration of most of the pollutants of concern for this activity. The above-mentioned ordinances contain specific requirements for buffer setbacks.
- Logging access roads must have a crushed rock or spall apron construction entrance where they join the pavement to prevent sediments from being tracked onto the pavement.
- On-site fueling and maintenance operations must follow the required BMPs as outlined in A204 Mobile Fueling; A203 Vehicle Maintenance; and A407 Storage of Liquid, Food Waste, or Dangerous Waste Containers.

#### **4.8.4.3 Recommended BMPs**

The following BMPs are not required, but can provide additional pollution protection:

- Erosion potential can be reduced by avoiding logging on steep slopes.
- If access roads are constructed for logging, they should be provided with drainage ditches that divert runoff into vegetated areas or stormwater treatment systems.
- Plant vegetated buffers in areas where they are already downslope of proposed logging areas, with sufficient lead time to allow for effective growth.

### **4.8.5 BMP A705: Mining and Quarrying of Sand, Gravel, Rock, Peat, Clay and Other Materials**

#### **4.8.5.1 Description of Pollutant Sources**

This activity applies to surface excavation and on-site storage of sand, gravel, and other materials that are mined. All mining operations that have stormwater runoff from the site are required to apply for a National Pollutant Discharge Elimination System (NPDES) permit with the Department of Ecology. Ecology has specific BMPs required by the permit. Some additional BMPs to help meet Ecology's discharge performance standards are listed below. Other permits from the Washington Department of Natural Resources and the City of Tacoma Planning and Development Services Division may be required.

Pollutants of concern are suspended solids, nutrients, pH, oils, and metals.

#### **4.8.5.2 Required BMPs**

- Measures to control track-out and dust shall be implemented. Wheel washes, sweeping, and paving high traffic areas are some common practices.

#### **4.8.5.3 Recommended BMPs**

- If the material is appropriate, use excavated spoil material to form compacted berms along downslope sides of the site to contain runoff. Berms should be seeded to promote growth of grass or other vegetation to limit erosion from the berms. Safety measures to prevent flooding due to berm failure shall be considered.
- Semi-permanent stockpiles should be protected from erosion.
- Use sediment ponds to promote settling of suspended solids. Refer to Volume 5 of this manual for more information.
- Use anchored tarps to cover stockpiles at small-scale mining operations if there is a potential for contaminated stormwater to leave the site.
- Provide containment and or cover for any on-site storage areas to prevent run-on and discharge of suspended solids and other pollutants.

### **4.8.6 BMP A706: Swimming Pool and Spa Cleaning and Maintenance**

#### **4.8.6.1 Description of Pollutant Sources**

This activity applies to all municipal and commercial swimming pools and spas, including Tacoma-Pierce County Health Department (TPCHD) regulated facilities. Pools and spas at hotels, motels, and apartment and condominium complexes are covered here. Pools at single-family residences are covered in Chapter 3 of this volume. Commercial pool and spa cleaning services must follow the required BMPs for all pools serviced.

Pollutants of concern include nutrients, suspended solids, chlorine, pH, and chemical oxygen demand (COD).

#### **4.8.6.2 Required BMPs**

- The preferred method of pool or spa water disposal is to the sanitary sewer. If a sanitary sewer is available, all regulated facilities are required to connect for draining and backwash. Contact the City of Tacoma Source Control Unit at 253-591-5588 for specific instructions on allowable flow rates and timing before starting to drain the pool. Never discharge pool water to a septic system, as it may cause the system to fail.
- If discharge to the sanitary sewer is not possible, pool and spa water may be discharged to a ditch or storm drainage system, provided that the water has been dechlorinated first. The proponent is required to contact the City of Tacoma Source Control Unit at 253-591-5588 prior to discharge for instructions on allowable flow rates for the system or ditch that is being discharged to. All discharges shall be de-chlorinated to a concentration of 0.1 parts per million (ppm or mg/L) or less, and pH adjusted 6.5 to 8.5 standard units, if necessary. Neutralizing chemicals are available for dechlorinating water and adjusting the pH. Turbidity shall not exceed 10 NTU. Letting the pool or spa "sit" may also reduce chlorine levels. Use a test kit to determine if the chlorine concentration has reached zero and the pH is within acceptable limits.
- State law allows discharges of pool water to the ground, not to a water body or storm drainage system, with a chlorine level of up to 3 parts per million. However, the water must not cross property lines or impact neighboring properties, and a satisfactory means for distributing the water to the ground must be used so there is no runoff.

- Backwash from pool filters cannot be discharged to surface waters, storm drainage systems, septic systems, or on the ground.
- Diatomaceous earth used in pool filters cannot be discharged to surface waters, storm drainage systems, septic systems, or on the ground.

#### **4.8.6.3 Recommended BMP**

- Hire a professional pool-draining service to collect all pool water for offsite disposal.

### **4.8.7 BMP A707: De-Icing and Anti-Icing Operations for Streets & Highways**

#### **4.8.7.1 Description of Pollutant Sources**

Deicing and/or anti-icing compounds are used on highways, streets, and sidewalks to control ice and snow. Typically ethylene glycol and propylene glycol are deicers used on aircraft. Deicers commonly used on highways, streets and sidewalks include calcium magnesium acetate (CMA), calcium chloride, magnesium chloride, sodium chloride, urea, and potassium acetate. The deicing and anti-icing compounds become pollutants when they are conveyed to storm drains or to surface water after application. Leaks and spills of these chemicals can also occur during their handling and storage.

#### **4.8.7.2 Required BMPs**

- Select de-icers and anti-icers that cause the least adverse environmental impact. Apply only as needed using minimum quantities.
- Where feasible and practicable, use roadway deicers, such as calcium magnesium acetate, potassium acetate, or similar materials that cause less adverse environmental impact than urea and sodium chloride.
- Store and transfer de/anti-icing materials on an impervious containment pad in accordance with BMP A401 Storage or Transfer (Outside) of Solid Raw Materials, By-Products, or Finished Products and A408 Storage of Liquids in Above-Ground Tanks.
- Sweep/clean up accumulated de/anti-icing materials and grit from roads as soon as possible after the road surface clears.

#### **4.8.7.3 Recommended BMPs**

- Intensify roadway cleaning in early spring to help remove particulates from road surfaces.
- Include limits on toxic metals in the specifications for de/anti-icers.
- Additional guidance can be found in the Regional Road Maintenance - Endangered Species Act (ESA) program guidelines.
- State guidelines contain additional information for de-icing activities at airports.

### **4.8.8 BMP A708: Roof and Building Drains at Manufacturing and Commercial Buildings**

#### **4.8.8.1 Description of Pollutant Sources**

Stormwater runoff from roofs and sides of manufacturing and commercial buildings can be sources of pollutants caused by leaching of roofing materials, building vents, and other air emission sources. Vapors and entrained liquid and solid droplets/particles have been identified as potential pollutants in roof/building runoff. Metals, solvents, acidic/alkaline pH, BOD, and organics are some of the pollutant constituents identified.

#### **4.8.8.2 Required BMPs**

- Bare galvanized metal shall not be used for materials that convey stormwater, such as roofs, canopies, siding, gutters, downspouts, roof drains, and pipes. Any galvanized materials shall have an inert, non-leachable finish, such as a baked enamel, fluorocarbon paint (such as Kynar® or Hylar®), factory-applied epoxy, pure aluminum, or asphalt coating. Acrylic paint, polyester paint, field-applied, and part zinc (such as Galvalume®) coatings are not acceptable. See Ecology Publication #08-10-025 for additional information concerning practices to reduce zinc concentrations.
- If leachates and/or emissions from buildings are suspected sources of stormwater pollutants, these surfaces are considered pollution-generating impervious surfaces and may require treatment per Volume 1, 3.4.6 Minimum Requirements #6.
- If a roof/building stormwater pollutant source is identified, implement appropriate source control measures such as air pollution control equipment, selection of materials, operational changes, material recycle, process changes, etc.
- Water quality treatment BMPs are found in Volume 5 of this manual.

#### **4.8.9 BMP A709: Urban Streets**

##### **4.8.9.1 Description of Pollutant Sources**

Streets can be sources of vegetative debris, paper, fine dust, vehicle liquids, tire wear residues, heavy metals (lead and zinc), phthalates, soil particles, ice control salts, domestic wastes, animal wastes, lawn chemicals, and vehicle combustion by-products. Street surface contaminants have been found to contain significant concentrations of particle sizes less than 250 microns (Sartor and Boyd, 1972).

##### **4.8.9.2 Required BMPs**

- Conduct efficient street sweeping where and when appropriate to minimize the contamination of stormwater. Do not wash street debris into storm drains.

##### **4.8.9.3 Recommended BMPs**

- For maximum stormwater pollutant reductions on curbed streets and high volume parking lots, use efficient vacuum sweepers.
- High-efficiency street sweepers utilize strong vacuums and the mechanical action of main and gutter brooms combined with an air filtration system that only returns clean air to the atmosphere (i.e., filters very fine particulates). They sweep dry and use no water since they do not emit any dust.
- For moderate stormwater pollutant reductions on curbed streets, use regenerative air sweepers or tandem sweeping operations.
- A tandem sweeping operation involves a single pass of a mechanical sweeper followed immediately by a single pass of a vacuum sweeper or regenerative air sweeper.
  - A regenerative air sweeper blows air down on the pavement to entrain particles and uses a return vacuum to transport the material to the hopper.
  - These operations usually use water to control dust. This reduces their ability to pick up fine particulates.
- For minimal stormwater pollutant reductions on curbed streets, use mechanical sweepers.



**NOTE:** Mechanical sweepers are referred to as broom sweepers and use the mechanical action of main and gutter brooms to throw material on a conveyor belt that transports it to the hopper. These sweepers usually use water to control dust, reducing their ability to pick up fine particulates.

- Conduct sweeping at optimal frequencies. Optimal frequencies are those scheduled sweeping intervals that produce the most cost-effective annual reduction of pollutants normally found in stormwater and can vary depending on land use, traffic volume, and rainfall patterns.
- Train operators in those factors that result in optimal pollutant removal. These factors include sweeper speed, brush adjustment and rotation rate, sweeping pattern, maneuvering around parked vehicles, and interim storage and disposal methods.
- Minimize the amount of water applied for dust control to avoid washing pollutants into the storm drainage system.
- Street sweeping shall be performed prior to washing the street.
- Consider the use of periodic parking restrictions and public notification in residential areas to ensure the sweeper's ability to sweep along the curb.
- Establish procedures for prompt sweeping, removal, and disposal of spill clean-up materials and debris from special events that will generate higher than normal loadings.
- Disposal of street sweeping solids must comply with state solid waste regulations. Additional guidance can be found in the Regional Road Maintenance – Endangered Species Act (ESA) program guidelines.
- Inform citizens about the importance of eliminating yard debris, oil, and other wastes in street gutters in order to reduce street pollutant sources.
- When encountering questionable sweeping waste contact the City of Tacoma Source Control Unit at 253-591-5588 for guidance.

## **4.8.10 BMP A710: Railroad Yards**

### **4.8.10.1 Description of Pollutant Sources**

Pollutant sources can include drips/leaks of vehicle fluids and cargo onto the railroad bed; human waste disposal; litter; locomotive/railcar/equipment cleaning; fueling; outside material storage; the erosion and loss of soil particles from the railroad bed; maintenance and repair activities at railroad terminals, switching yards, and maintenance yards; and herbicides used for vegetation management. Waste materials can include waste oil, solvents, degreasers, antifreeze solutions, radiator flush, acids, brake fluids, dust, soiled rags, oil filters, sulfuric acid and battery sludges, machine chips with residual machining oil, and toxic fluids/solids lost during transit. Potential pollutants include oil and grease, TSS, BOD, organics, pesticides, and metals.

### **4.8.10.2 Required BMPs**

- Implement the applicable BMPs in this chapter depending on the pollutant generating activities/sources at a railroad yard facility.
- Do not allow toilets to discharge to outside areas while a train is in transit or at the station. Pumpout facilities shall be used to service train toilets.
- Use drip and track pans at hose/pipe connections during liquid transfer and other leak-prone areas.

- During maintenance do not discard debris or waste liquids along the tracks or in railroad yards.
- Promptly clean up all spilled materials.

In areas subject to leaks/spills of oils or other chemicals, convey the contaminated stormwater to appropriate treatment such as a CP or API oil/water separator for floating oils, or other appropriate treatment BMP (as approved by the City of Tacoma). See Volume 5. Prior to disposal, certain areas may require discharge to sanitary sewer.

## **4.8.11 BMP A711: Maintenance of Utility Vaults**

### **4.8.11.1 Description of Pollutant Sources**

Utility vaults can be a source of debris, oils and grease, or other contaminants.

### **4.8.11.2 Required BMPs**

- When water or sediments are removed from utility vaults, determine whether contaminants might be present before disposing of the water and sediments. This includes inspecting for the presence of oil or sheen, and determining from records or testing if the transformers contain PCBs. If records or tests indicate that the sediment or water are contaminated above applicable levels, manage contaminants in accordance with applicable federal and state regulations, including the federal PCB rules (40 CFR 761) and the state MTCA cleanup regulations (Chapter 173-340 WAC). Water removed from the vaults can be discharged in accordance with the federal 40 CFR 761.79, and state regulations (Chapter 173-201A WAC and Chapter 173-200 WAC), or via the sanitary sewer if the requirements, including applicable permits, for such a discharge are met. (See also Volume 4, Section 4.8.15).
- Ensure any spills are immediately cleaned

## **4.8.12 BMP A712: Maintenance of Roadside Ditches and Culverts**

### **4.8.12.1 Description of Pollutant Sources**

Common road debris including litter, eroded soil, oils, vegetative particles, and heavy metals can be sources of stormwater pollutants.

### **4.8.12.2 Required BMPs**

- Inspect roadside ditches and culverts regularly, as needed, to identify sediment accumulations and localized erosion.
- Clean ditches and culverts on a regular basis, as needed. Ditches shall be kept free of rubbish and debris.
- Vegetation in ditches often prevents erosion and cleanses runoff waters. Remove vegetation only when flow is blocked or excess sediments have accumulated. Conduct ditch maintenance (seeding and harvesting) in late spring and/or early fall, where possible. Consider leaving segments of undisturbed vegetation to provide natural filtration.
- In the area between the edge of the pavement and the bottom of the ditch, commonly known as the "bare earth zone," use grass vegetation, wherever possible. Vegetation shall be established from the edge of the pavement if possible, or at least from the top of the slope of the ditch.

- Diversion ditches on top of cut slopes that are constructed to prevent slope erosion by intercepting surface drainage must be maintained to retain their diversion shape and capability.
- Do not leave ditch cleanings on the roadway surfaces. Promptly sweep dirt and debris remaining on the pavement as needed and at the completion of ditch cleaning operations.
- Roadside ditch cleanings not contaminated by spills or other releases and not associated with a stormwater treatment system such as a bioswale may be screened to remove litter and separated into soil and vegetative matter (leaves, grass, needles, branches, etc.). The soil fraction may be handled as 'clean soils' and the vegetative matter can be composted or disposed of in a municipal waste landfill.
- Roadside ditch cleanings contaminated by spills or other releases known or suspected to contain dangerous waste must be handled following the Dangerous Waste Regulations (Chapter 173-303 WAC) unless testing determines it is not dangerous waste. Specific cleanup standards are set forth in the Model Toxics Control Act (Chapter 70.105D RCW) and Regulations (Chapter 173-340 WAC).
- Inspect culverts on a regular basis for scour or sedimentation at the inlet and outlet, and repair as necessary. Give priority to those culverts conveying perennial and/or salmon-bearing streams and culverts near streams in areas of high sediment load, such as those near subdivisions during construction.
- Street waste shall be disposed of in accordance with Volume 4, Appendix D.

### **4.8.12.3 Recommended BMPs**

- Install biofiltration swales and filter strips to treat roadside runoff wherever practicable and use engineered topsoils wherever necessary to maintain adequate vegetation. These systems can improve infiltration and stormwater pollutant control upstream of roadside ditches. Refer to Volume 5 of this manual for additional information about biofiltration swales and filter strips.
- Additional guidance can be found in the Regional Road Maintenance - Endangered Species Act (ESA) program guidelines.

## **4.8.13 BMP A713: Spills of Oil and Hazardous Substances**

### **4.8.13.1 Description of Pollutant Sources**

Owners or operators of facilities engaged in drilling, producing, handling, gathering, storing, processing, transferring, distributing, refining or consuming oil and/or oil products are required by Federal Law to have a Spill Prevention and Control Plan. The federal definition of oil is oil of any kind or any form, including, but not limited to, petroleum, fuel oil, sludge, oil refuse, and oil mixed with wastes other than dredged spoil. Specific regulations can be found in 40 CFR Part 112. These regulations are administered by the Environmental Protection Agency and the United States Coast Guard. Large petroleum handling facilities and vessels are also subject to regulations contained in Chapter 90.56 RCW and Chapter 173-180A WAC.

Owners of businesses that produce Dangerous Wastes are also required by State Law, Chapter 70.105 RCW and Chapter 173-303 WAC, to have a spill control plan. The City of Tacoma may also require a spill plan to protect the municipal sewer system and groundwater resources. Plans required by the above listed regulations may suffice.

### **4.8.13.2 Required BMPs**

- Prepare an Emergency Spill Control Plan (SCP), which includes:
  - A description of the facility including the owner's name and address.
  - The nature of the activity at the facility.
  - The general types of chemicals used or stored at the facility.
  - A site plan showing the location of storage areas for chemicals, the locations of storm and sanitary drains, the areas draining to them, the ultimate point of discharge, and the location and description of any devices to stop spills from leaving the site such as positive control valves;
  - Cleanup procedures and supplies.
  - Notification procedures to be used in the event of a spill, such as notifying key personnel. Agencies such as Ecology, Tacoma Fire Department, Washington State Patrol, City of Tacoma, U.S. Coast Guard, and the U.S. Environmental Protection Agency shall be notified.
  - The name and 24-hour contact telephone number of the designated person, and their alternate with overall spill cleanup and notification responsibility.
  - Identify contractors that can be contacted to provide spill clean-up and disposal services. A service agreement is encouraged.

- Train key personnel in the implementation of the Emergency SCP. Prepare a summary of the plan and post it at appropriate points in the building, identifying the spill cleanup coordinators, location of cleanup kits, and 24-hour phone numbers of regulatory agencies to be contacted in the event of a spill.
- Update the SCP regularly.
- Immediately notify Ecology and the City of Tacoma if a spill may reach sanitary or storm sewers, groundwater, or surface water, in accordance with federal and Ecology spill reporting requirements.
- Immediately clean up spills using appropriate personal protection equipment and following the facility safety standards. Do not use emulsifiers for cleanup unless an appropriate disposal method for the resulting oily wastewater is implemented. Absorbent material shall not be washed down a floor drain or storm sewer.
- Locate emergency spill containment and cleanup kit(s) in high potential spill areas. The contents of the kit shall be appropriate for the type and quantities of chemical liquids stored at the facility.

#### **4.8.13.3 Recommended BMPs**

- Spill kits should include appropriately lined drums, absorbent pads, and granular or powdered materials for neutralizing acids or alkaline liquids where applicable. In fueling areas: absorbent should be packaged in small bags for easy use and small drums should be available for storage of absorbent and/or used absorbent. Spill kits should be deployed in a manner that allows rapid access and use by employees.
- Example spill plans may be obtained from the Washington State Department of Transportation, the Environmental Protection Agency, and the City of Tacoma Source Control Unit.

#### **4.8.13.4 Additional Links**

- Washington State Department of Ecology, FOCUS: Small Spill Cleanup Guide  
<http://www.ecy.wa.gov/biblio/0308005.html>
- Washington State Department of Ecology, Hazmat Spill Contractor List:  
[http://www.ecy.wa.gov/programs/spills/spills\\_happen/main.html](http://www.ecy.wa.gov/programs/spills/spills_happen/main.html)
- Washington State Department of Ecology, Spill Reporting, 24/7 Numbers:  
<http://www.ecy.wa.gov/programs/spills/other/reportaspill.htm>
- Washington State Department of Ecology, Incident Command System and National Incident Management System  
<http://www.ecy.wa.gov/programs/spills/preparedness/Drills/ics.html>
- Washington State Department of Transportation, Spill Prevention Control and Countermeasures (SPCC)  
<http://www.wsdot.wa.gov/Environment/HazMat/SpillPrevention.htm>
- Environmental Protection Agency, Spill Prevention, Control and Countermeasure (SPCC)  
<http://www.epa.gov/oem/content/spcc/index.htm>
- Washington State Legislature, WAC 173-303-145 Spills and Discharges into the Environment  
<http://apps.leg.wa.gov/WAC/default.aspx?cite=173-303-145>

#### **4.8.14 BMP A714: Water Reservoir, Transmission Mainline, Wellhead, and Hydrant Flushing Activities**

##### **4.8.14.1 Description of Pollutant Sources**

Construction and operation of drinking water infrastructure, as well as emergency response activities, can generate sediments, rust, turbidity and suspended solids, bacteria, and chlorinated water. Flushing of the water delivery system is necessary to maintain drinking water quality and ensure public health. Flushing activities can result in increased flows in downstream conveyances. These high flows may cause flooding and create erosion in downstream channels.

##### **4.8.14.2 Required BMPs**

- Discharges of untreated hyperchlorinated water must go to the sanitary sewer. Prior approval is required.
- Alternatively, non-emergency discharges of de-chlorinated potable water such as hydrant flushing may go to the storm drainage system at prior approved flow rates provided the following limits are met:
  - Chlorine residual 0.1 ppm
  - pH 6.5 – 8.5
  - Turbidity 10 NTU

Coordinate with the City of Tacoma Sewer Transmission section at 253-591-5585. The receiving storm pipe shall be monitored for the duration of the discharge.

- Evaluation of the receiving conveyance system for capacity and/or obstructions may be required.
- A Special Approved Discharge Authorization may be required for draining and flushing reservoirs, standpipes, wellheads, and transmission lines. Notification, monitoring, reporting, flow control measures, and other special conditions may apply. Contact the City of Tacoma Source Control Unit at 253-591-5588 for their requirements.
- Significant releases of water can have a detrimental effect on the storm and sanitary transmission system as well as receiving waters. Notification of these releases must be promptly made to Environmental Services by calling the 24-hour Operations Center at 253-591-5595.

##### **4.8.14.3 Recommended BMPs**

- During emergency repairs and activities, such as mainline breaks, erosion control measures shall be taken as practicable. Use of sandbags, check dams, plastic sheeting, pumps, and other erosion control measures should be employed to minimize erosion as much as possible.
- Excavation de-watering should be managed to minimize downstream environmental impacts. Use of vector trucks, diverting flow to grassy areas, filter bags, and retention ponds should be employed.

#### **4.8.15 BMP S101: Eliminate Illicit Storm Drainage System Connections**

A common problem found in the storm drain system for Tacoma is illegal hook-ups to the system. Conversely, discharging clean, uncontaminated water to the sanitary sewer system is also prohibited.

All businesses and residences in Tacoma shall examine their plumbing systems to determine if illicit connections exist. Any time it is found that toilets, sinks, appliances, showers and bathtubs, floor drains, industrial process waters, cooling towers, or other indoor activities are connected to the storm drainage system, the connections must be immediately rerouted to the sanitary or septic system, holding tanks, or process treatment system. Exceptions to this requirement would be those industries and businesses that have been issued an NPDES Permit by Ecology, and are allowed specific discharges under that permit. Contact Ecology to determine which permits might apply to your project site.

Dye testing with a non-toxic dye, smoke testing, electronic locators, and television inspection equipment can help to determine where a pipe or structure drains if it is not obvious by observations or on plans. Contact the City of Tacoma Source Control Unit at 253-591-5588 for assistance in locating City structures adjacent to a property.

Drains which are found to be connected to the wrong system must either be permanently plugged or disconnected and rerouted as soon as possible. Permits must be obtained from The City of Tacoma (253-591-5030) to reroute drains. If the discharge is anything other than domestic, then a holding tank or on-site treatment may be necessary. Contact the City of Tacoma Source Control Unit at 253-591-5588 for assistance.

#### **4.8.16 BMP S102: Dispose of Contaminated Stormwater and Waste Materials Properly**

Every business and residence in Tacoma must dispose of solid and liquid wastes and contaminated stormwater properly. There are generally four options for disposal depending on the type of materials. These options include:

- Sanitary sewer and septic systems
- Recycling facilities
- Municipal or private, permitted solid waste disposal facilities
- Permitted hazardous waste treatment, storage, and disposal facilities

Many liquid wastes and contaminated stormwater (depending on the pollutants and associated concentrations present) can be put into the sanitary sewer. Animal wastes can also be disposed of in a sanitary sewer. A City permit may be required for discharges to the sanitary sewer system. Please contact Planning and Development Services at 253-591-5030 and the Source Control Unit at 253-591-5588 for design and permit requirements. See Appendix D for Street Waste Management Requirements.

If wastes cannot be legally discharged to a sanitary sewer or septic system, one of the other three disposal options must be used. Recycling facilities are a recommended option for many commercial and household items, including used oils, used batteries, old equipment, glass, some plastics, metal scrap materials, solvents, paints, wood and land clearing wastes, and various other solid wastes.

Solid wastes that cannot be recycled and that are not hazardous must be disposed of at a licensed municipal solid waste disposal facility. Dangerous and hazardous wastes must be properly transported to an appropriate hazardous waste treatment, storage, and disposal facility. The City of Tacoma Solid Waste Section at 253-591-5543 can provide information on waste disposal options.

Maintain records for all materials that are recycled or disposed.

Appendix A of this volume has a list of telephone numbers to contact for assistance.

#### **4.8.17 BMP S103: Discharge Process Wastewater to a Sanitary Sewer, Holding Tank, or Water Treatment System**

This BMP is a minimum requirement for all industrial and commercial activities that generate contaminated process wastewater, such as washing activities, composting activities, and production and processing activities. The water used in these activities shall not drain to surface waters or groundwater untreated. Process water must drain to a sanitary sewer, holding tank, on-site treatment system, wastewater treatment system, or be recycled.

In order to connect to the sanitary sewer, contact Tacoma Planning and Development Services at 253-591-5030 for information on sanitary sewer connection permits. Call the City of Tacoma Source Control Unit at 253-591-5588 for pretreatment and permit information.

If a sanitary sewer is not available, the only remaining options are holding tanks or an on-site wastewater treatment facility.

The contents of the holding tank must be pumped out or drained before the tank is full and disposed of properly (see BMP S102).

If the on-site wastewater treatment facility option is taken, then it must be designed to receive and effectively treat all discharges of process water from the business. The Washington State Department of Ecology must be contacted for approval of such a facility.

If the activity is to remain uncovered, then define a designated area for the activity and provide a mechanism for prevention of stormwater run-on into the activity area. (e.g. a curb, dike, or berm). The designated area shall be paved and sloped to a central collection drain and be connected to the sanitary sewer, (with pretreatment if required), the on-site holding tank, or the on-site treatment facility, whichever method is selected.

Monitoring and maintaining all collection systems and keeping records of inspections and maintenance may be required.



## 4.9 Cover and Surround Activities

### 4.9.1 BMP S104: Cover the Activity with a Roof or Awning

In many cases, a simple roof or awning will protect the activity from coming into contact with stormwater, and usually at a lower cost than a complete building. These structures require building permits to construct. Contact the Tacoma Planning and Development Services at 253-591-5030 to obtain permits.

The area of the roof cover shall be sufficient to prevent any precipitation from reaching the covered materials. Provisions shall be made to prevent stormwater run-on into the covered area. The installation of sumps or sanitary sewer drains may also be necessary. Roof drains shall discharge outside and be directed away from the covered area. Examples of these types of structures are shown in Figure 4 - 15.

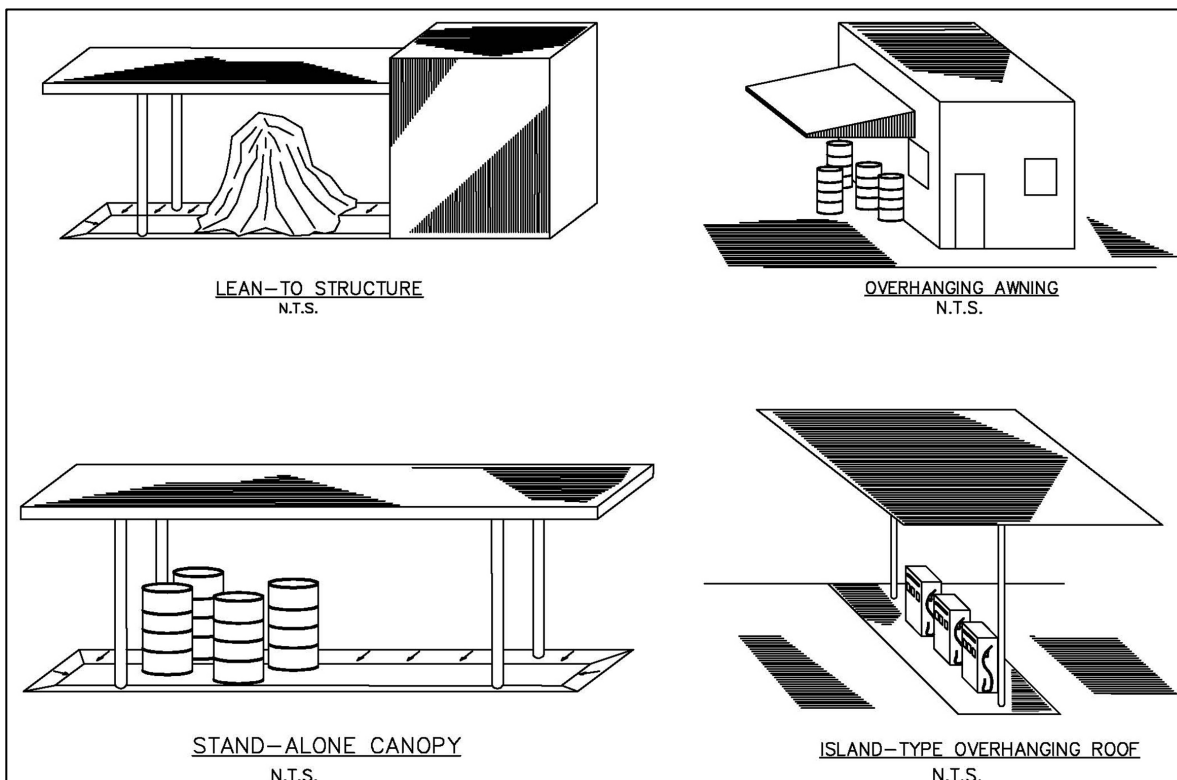


Figure 4 - 15. Examples of Covered Activities

### 4.9.2 BMP S105: Cover the Activity with an Anchored Tarp or Plastic Sheet

Some activities, such as stockpiling of raw materials, can be effectively covered with a sturdy tarp or heavy plastic sheet made of impermeable material. Weights such as bricks, tires, or sandbags should be used to anchor the cover in place. Run-on shall be prevented from reaching the activity or material. Stormwater run-off from the cover shall be directed away from the stockpile and work zone, and if uncontaminated, directed to the stormwater collection system.

The tarp must be inspected daily to ensure that no holes or gaps are present in the tarp coverage. An example of this type of cover is shown in Figure 4 - 16.

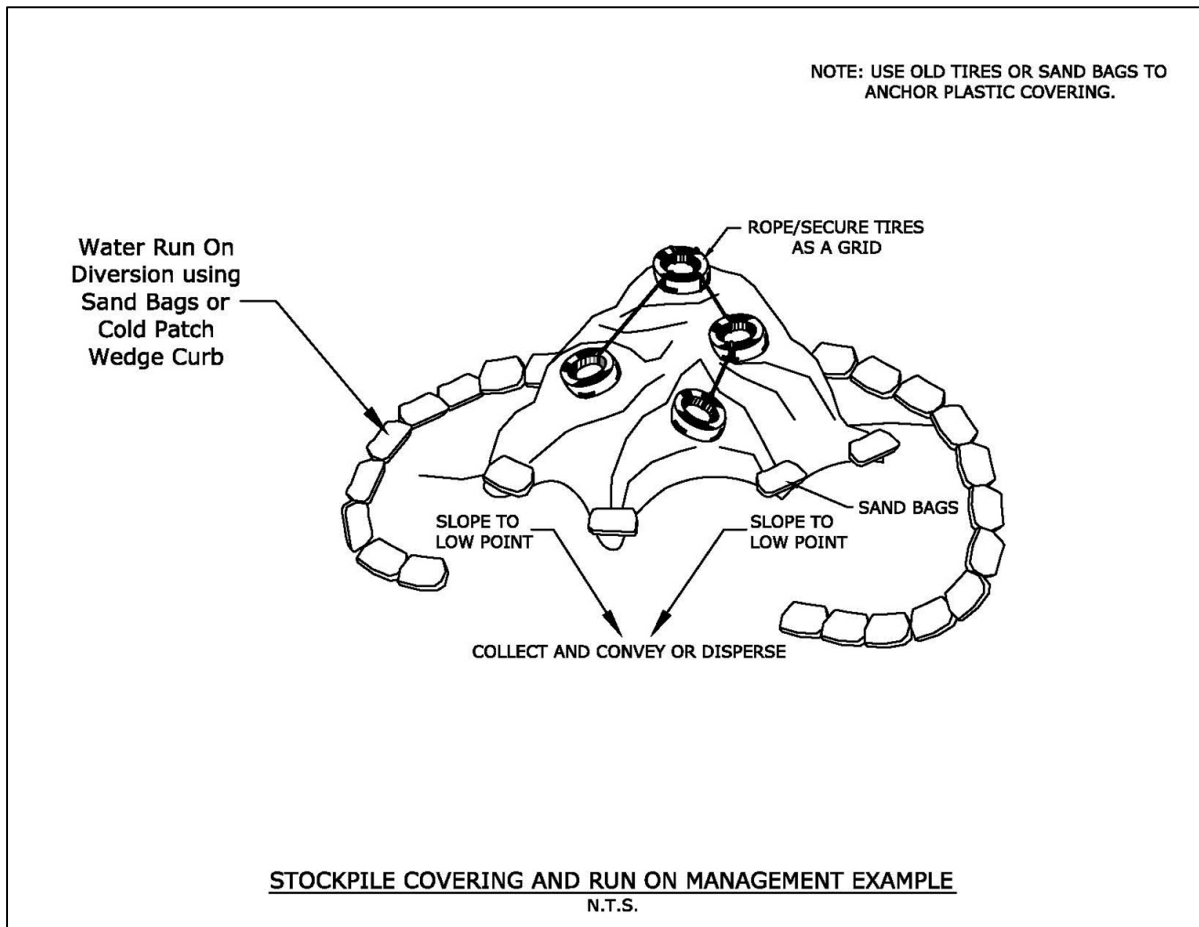
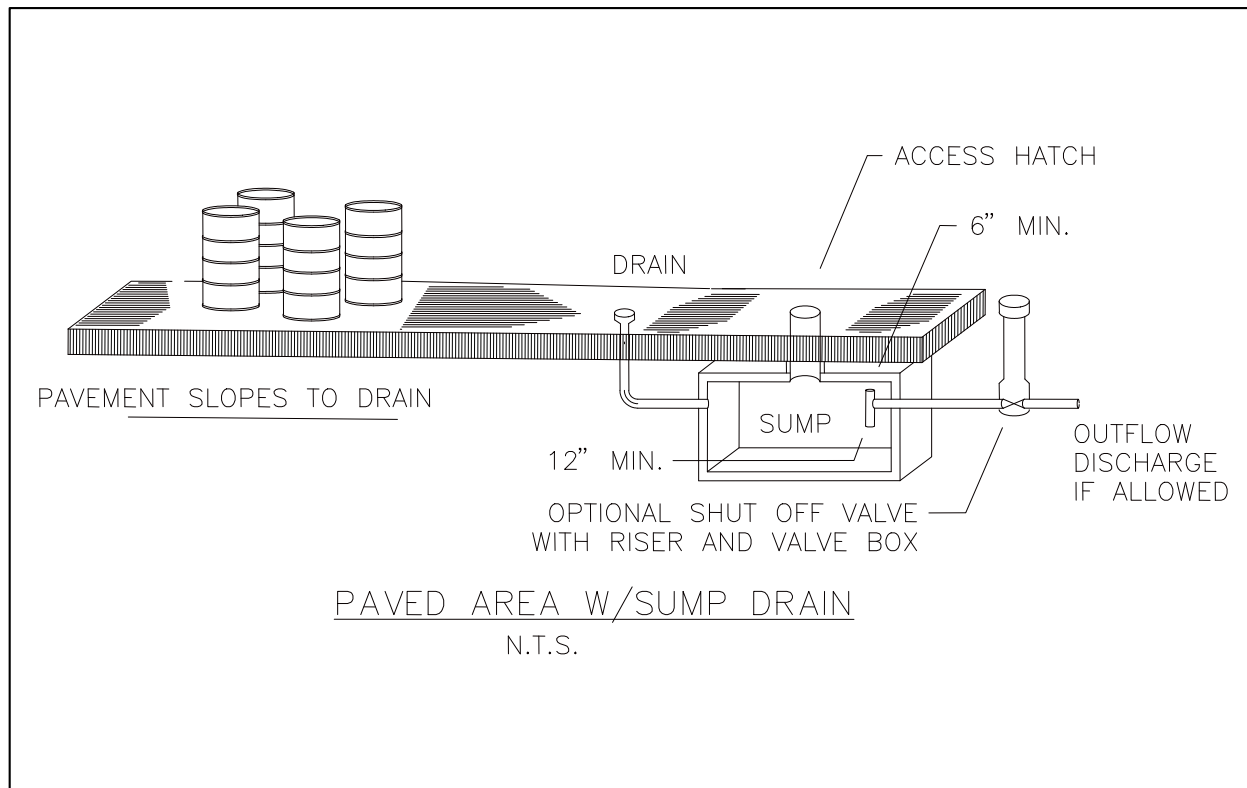


Figure 4 - 16. Tarp Covering

#### 4.9.3 BMP S106: Pave the Activity Area and Slope to a Sump, Holding Tank, or Oil/Water Separator

This BMP applies to several activities that cannot be covered effectively. It is particularly suited to activities with the potential for leaks and spills, but that otherwise do not generate excessive amounts of polluted runoff. The activity area shall be paved and sloped to a central collection point. A sump, holding tank, or oil/water separator (Figure 4 - 17) serves to provide spill containment until the liquids can be pumped out and properly disposed. The minimum volume for the sump shall be equivalent to the volume generated by the anticipated activity plus rain water. Sizing justification shall be included in design submittals.

To prevent run-on, the area should be enclosed with a berm, curb, or dike. Frequent inspections of the sump, holding tank, or oil/water separator are necessary. Inspections and maintenance shall be recorded in a log. Commercial services that pump sumps and holding tanks are listed in the Yellow Pages of the phone directory under Environmental and Ecological Services.



**Figure 4 - 17. Paved Area with Sump Drain**

#### **4.9.4 BMP S107: Surround the Activity Area with a Curb, Dike, or Berm or Elevate the Activity**

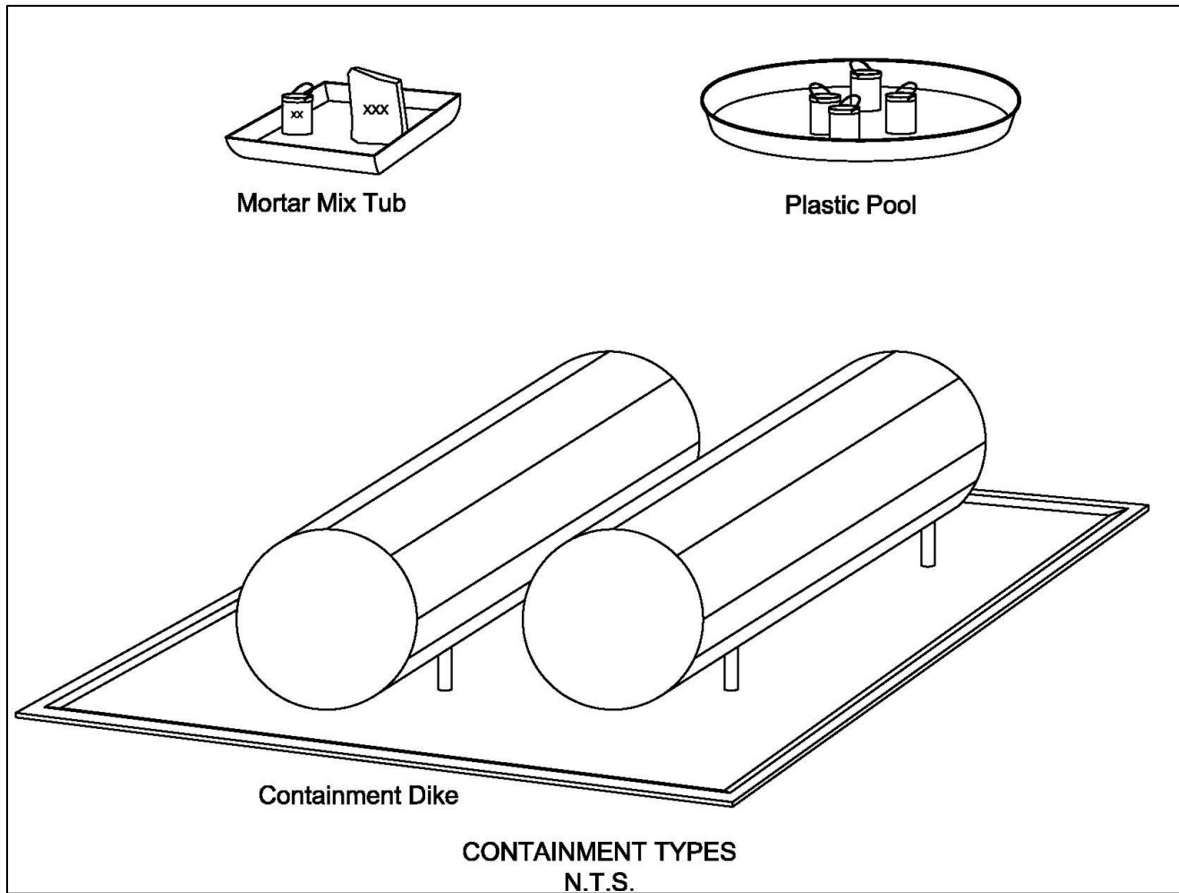
This set of BMP options can be an effective means for prevention of stormwater run-on to an activity area. In addition, a curb, berm, or dike can be used for containment of spills in the activity area, or for containment of contaminated activity runoff. Generally, a containment BMP is most applicable to spill control situations; that is, sites where runoff is relatively clean, but occasional spills may occur.

If a curb, berm, or dike is used for runoff containment, and other containment sizing regulations (such as fire codes, Environmental Protection Agency, Department of Ecology or Tacoma-Pierce County Health Department restrictions) do not apply, the containment volume shall be 100% of the volume of the largest tank plus the volume of stormwater runoff from rain events up to the 25-year, 24-hour storm within the containment area is contained or 110% of the volume of the largest tank, whichever is greater.

Impervious containment may consist of membrane lined soil enclosures, containment pallets, plastic pools, mortar mixing tubs, and water troughs.

Regular inspections of the containment area and proper management of any collected stormwater is required.

Development of a spill plan may be necessary for storage of liquids. See BMP A714. For permanent storage facilities see BMP A202, A401, A407, and A408.



**Figure 4 - 18. Containment Types**

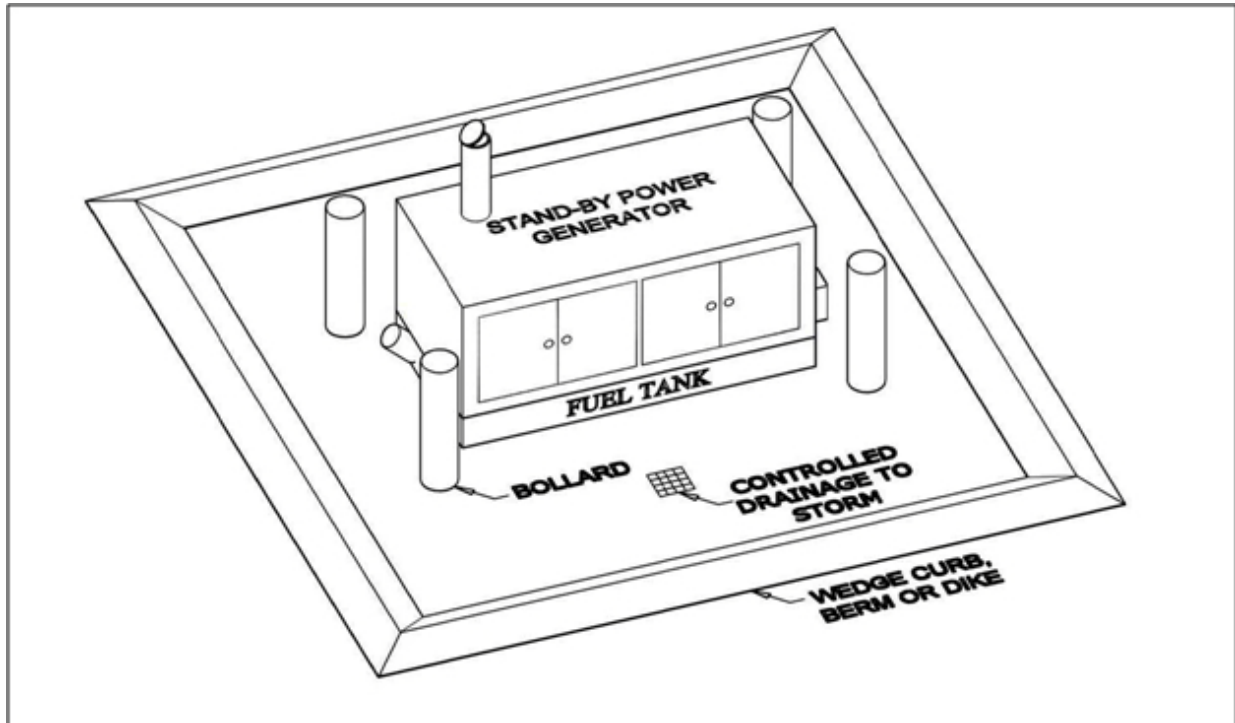


Figure 4 - 19. Standby Generator

#### 4.10 BMP S108: Implement Integrated Pest Management Measures

Use of herbicides, fungicides, and rodenticides should always be done with extreme caution, not only because of the potential harm to humans and pets, but also because of the potential harm to fish, wildlife, and our water resources. In light of the toxic nature of these compounds, special attention should be given to pesticide usage in all applications. The discussion below applies more to large-scale licensed pesticide users, but should be considered for backyard applications as well.

Commercial, agricultural, municipal, and other large scale pesticide users, such as golf courses and parks, should adhere to the principles of integrated pest management (IPM), a decision-making process for pest management that strives for intelligent, environmentally sound control of pests. It is a systems approach to pest management that combines agronomic, biological, chemical, and genetic information for educated decisions on the type of control to use, the timing and extent of chemical application, and whether non-chemical means can attain an acceptable level of pest control.

IPM is a preventive measure aimed at knowing the exact pests being targeted for control, the locations and times when pests will pose problems, the level of pest-induced damage that can be tolerated without taking action, the most vulnerable life stage, and control actions that are least damaging to the environment. The major components of IPM are as follows:

- Monitoring and inventory of pest populations

- Determination of pest-induced injury and action levels
- Identification of priority pest problems
- Selection and timing of least toxic management tools
- Site-specific treatment with minimized chemical use
- Evaluation and adjustment of pesticide applications

Monitoring of pest populations is a key to successful IPM implementation. Pest problems are universally easier to control if the problem can be discovered early. With IPM, pesticides are used only as a last resort. Maximization of natural controls, including biological controls and removal of pests by hand, is always the first choice.

Additional concerns are storage, equipment clean-up, spill protocols, and waste disposal.

More information on IPM is available from the Washington State Department of Agriculture and from the Washington State University Extension Service, or in Appendix C of this volume.

#### **4.11 BMP S109: Cleaning Catch Basins**

Cleaning catch basins regularly is one of the most important stormwater source control measures that a business can take. Catch basins are typically located at low spots in parking lots, along curbs and road edges, and where storm drain pipes combine flows. Catch basins collect surface runoff for storm drains that are typically located directly underneath them. Most catch basins have sumps. The sump is intended to trap sediments, debris, and other particles that can settle out of stormwater. All of the solids and stagnant water collected from catch basin sumps must be disposed of properly. The sump contents shall not be flushed into the catch basin outflow pipe.

For additional information on the maintenance of catch basins, refer to Volume 1, Appendix D. Perform regular inspections of the basins and their grates. Repair broken grates and catch basin structures. Remove trash and collected sediment when 60% of the sump depth has been filled or sediments are within 6 inches of the bottom of the outlet pipe, or if there is evidence of contaminants including oil and grease.

It should be apparent that the use of other BMPs, such as frequent sweeping of activity areas, covering activity areas, reducing activity occurrence, and containing run-off from activity areas will help reduce catch basin cleaning frequency, thus saving time and money. All businesses and agencies should set up maintenance schedules for all of their BMPs so coordinated BMP maintenance efforts results in reduced catch basin cleaning frequencies.

Use of catch basin inserts such as filter socks, absorbent pillows, and filter baskets require an increased inspection frequency to prevent plugging and flooding.

For a list of cleaning and sweeping services, go to [www.cityoftacoma.org/stormwater](http://www.cityoftacoma.org/stormwater).

Dispose of street waste in accordance with Appendix D of this volume.

**This Page Intentionally Left Blank**

## Appendix A Quick Reference Phone Numbers

Environmental Protection Agency (EPA) - Region X	800-424-4372
City of Tacoma	
Stormwater Source Control	253-591-5588
Sanitary Source Control	253-591-5588
Pretreatment Program	253-591-5588
Planning and Development Services (Permits)	253-591-5030
Fire Prevention Bureau	253-591-5740
Solid Waste Management Utility	253-591-5543
Household Hazardous Waste	253-591-5418
Recycling Services	253-591-5543
Tacoma-Pierce County Health Department	
On-Site Sewage and Underground Storage Tanks	253-798-4788
Hazardous Waste Section	253-798-6047
Solid Waste	253-798-6047
Pest Control Operators and Fumigators	253-798-6470
Washington State Department of Agriculture	360-902-2010 877-301-4555
Washington State Department of Ecology	360-407-6000
Southwest Regional Office	360-407-6300
Dangerous/Hazardous Waste	360-407-6300
NPDES Stormwater or Wastewater Permits	360-407-6400
Spill Reporting	800-424-8802
Recycling	800-732-9253
Groundwater Quality and Protection	360-407-6400
Underground and Above Ground Storage Tanks	360-407-7170
Washington State University/Pierce County Cooperative Extension	253-798-7180
Puyallup Tribe	253-597-6200
Puget Sound Clean Air Agency	800-552-3565



**This Page Intentionally Left Blank**

## Appendix B Recycling/Disposal of Vehicle Fluids and Other Wastes

The information in this appendix was obtained from Ecology's Hazardous Waste Program. For a copy of "Hazardous Waste Services Directory", Publication #91-12S, Revised December 1994, call Ecology's Hazardous Waste and Toxic Reduction Program at (360) 407-6721.

Material	Recommended Management
<b>Antifreeze</b>	Store separately for resale. Separate ethylene glycol from propylene glycol for off-site recycling. If not recyclable, send to Treatment, Storage, and Disposal Facility (TSDF) for disposal.
<b>Batteries</b>	INTACT: Accumulate under cover prior to sale, deliver to recycler or, return to manufacturer. BROKEN: Accumulate acid from broken batteries in resistant containers with secondary containment. Send to TSDF for disposal.
<b>Brake fluid</b>	Accumulate in separate, marked, closed container. Do not mix with waste oil. Recycle.
<b>Fuel</b>	Store gasoline, and diesel separately for use or resale. Mixtures of diesel, gasoline, oil, and other fluids may not be recyclable and may require expensive disposal.
<b>Fuel filters</b>	Drain fluids for use as product. With approval of local landfill operator, dispose to dumpster, if needed.
<b>Oil filters</b>	Puncture the filter dome and drain it for 24 hours. Put oil drained from filters into a "USED OIL ONLY" container. Keep drained filters in a separate container marked "USED OIL FILTERS ONLY." Locate a scrap metal dealer who will pick up and recycle filters. With approval of local landfill operator, dispose of drained filters to dumpster.
<b>Paint</b>	Accumulate oil-based and water-based paints separately for use or resale. If not recyclable, send accumulations to TSDF for disposal.
<b>Power steering fluid</b>	Same as for used oils
<b>Shop towels/oily rags</b>	Use cloth towels that can be laundered and reused. Accumulate used shop towels in a closed container. Sign up with an industrial laundry service that can recycle your towels.
<b>Solvents</b>	Consider using less hazardous solvents or switching to a spray cabinet that doesn't use solvent. Accumulate solvents separately. Consider purchasing a solvent still and recycling solvent on site. Do not mix with used oil. Do not evaporate as a means of disposal.
<b>Transmission oil, differential and rear end fluids</b>	Accumulate in your "USED OIL ONLY" container. Arrange for pickup for off-site recycling.
<b>Used oils; including, crankcase oil, transmission oil, power steering fluid and differential/rear end oil</b>	Keep used oil in a separate container marked "USED OIL ONLY." Do not mix with brake fluid, or used antifreeze. Do not mix with any other waste if material will be burned for heating. Arrange for pickup for off-site recycling.
<b>Windshield washer fluid</b>	Accumulate separately for use or resale. Discharge to on-site sewage disposal, or, if acceptable by the local sewer authority, discharge to sanitary sewer.

**This Page Intentionally Left Blank**

## **Appendix C Example of an Integrated Pest Management Program**

Integrated Pest Management (IPM) is a natural, long-term, ecologically based systems approach to controlling pest populations. This system uses techniques either to reduce pest populations or maintain them at levels below those causing economic injury, or to so manipulate the populations that they are prevented from causing injury. The goals of IPM are to encourage optimal selective pesticide use (away from prophylactic, broad spectrum use), and to maximize natural controls to minimize the environmental side effects.

A step-by-step comprehensive Integrated Pest Management (IPM) Program is provided below as a guide.

### **Introduction**

This section provides a sound cultural approach to managing lawns and landscapes and minimizing runoff. Many homeowners or property managers will be able to implement most or all of this approach. Others will wish to hire these services out. For the do-it yourselfer, an array of resources are available to assist in the effort. Landscaping businesses, agricultural extensions, local agencies, master gardener programs, local nurseries, and the library can all provide assistance. Landscaping professionals (businesses) are particularly encouraged to practice IPM.

### **Definition**

“Integrated pest management, or IPM, is an approach to pest control that uses regular monitoring to determine if and when treatments are needed, and employs physical, mechanical, cultural, and biological tactics to keep pest numbers low enough to prevent intolerable damage or annoyance. Least-toxic chemical controls are used as a last resort.”

True IPM is a powerful approach that anticipates and prevents most problems through proper cultural practices and careful observation. Knowledge of the life cycles of the host plants and both beneficial and pest organisms is also important. The IPM section of this example is adapted from “Least Toxic Pest Management for Lawns” by Sheila Daar. Following the IPM process yields the information needed to minimize damage by weeds, diseases, and pests and to treat those problems with the least toxic approaches.

### **The Integrated Pest Management Process**

#### **Step 1. Correctly identify problem pests and understand their life cycle.**

Learn more about the pest. Observe it and pay attention to any damage that may be occurring. Learn about the life cycle. Many pests are only a problem during certain seasons, or can only be treated effectively in certain phases of the life cycle.

#### **Step 2. Establish tolerance thresholds for pests.**

Every landscape has a population of some pest insects, weeds, and diseases. This is good because it supports a population of beneficial species that keep pest numbers in check. Beneficial organisms may compete with, eat, or parasitize disease or pest organisms. Decide on the level of infestation that must be exceeded before treatment needs to be considered. Pest populations under this threshold should be monitored but don't need treatment. For instance, European crane flies usually don't do serious damage to a lawn unless there are between 25-40 larvae per square foot feeding on the turf in February (in normal weather years). Also, most

people consider a lawn healthy and well maintained even with up to 20% weed cover, so treatment, other than continuing good maintenance practices, is generally unnecessary.

### **Step 3. Monitor to detect and prevent pest problems.**

Regular monitoring is a key practice to anticipate and prevent major pest outbreaks. It begins with a visual evaluation of the lawn or landscape's condition. Take a few minutes before mowing to walk around and look for problems. Keep a notebook, record when and where a problem occurs, then monitor for it at about the same time in future years. Specific monitoring techniques can be used in the appropriate season for some potential problem pests, such as European crane fly.

### **Step 4. Modify the maintenance program to promote healthy plants and discourage pests.**

A healthy landscape is resistant to most pest problems. Lawn aeration and overseeding along with proper mowing height, fertilization, and irrigation will help the grass out-compete weeds. Correcting drainage problems and letting soil dry out between waterings in the summer may reduce the number of crane-fly larvae that survive.

### **Step 5. If pests exceed the tolerance thresholds**

Use cultural, physical, mechanical, or biological controls first. If those prove insufficient, use the chemical controls described below that have the least non-target impact. When a pest outbreak strikes (or monitoring shows one is imminent), implement IPM then consider control options that are the least toxic, or have the least non-target impact. Here are two examples of an IPM approach:

- **Red thread disease** is most likely under low nitrogen fertility conditions and most severe during slow growth conditions. Mow and bag the clippings to remove diseased blades. Fertilize lightly to help the grass recover, then begin grasscycling and change to fall fertilization with a slow-release or natural-organic fertilizer to provide an even supply of nutrients. Chemical fungicides are not recommended because red thread cannot kill the lawn.
- **Crane fly damage** is most prevalent on lawns that stay wet in the winter and are irrigated in the summer. Correct the winter drainage and/or allow the soil to dry between irrigation cycles; larvae are susceptible to drying out, so these changes can reduce their numbers. It may also be possible to reduce crane fly larvae numbers by using a power de-thatcher on a cool, cloudy day when feeding is occurring close to the surface. Studies are being conducted using beneficial nematodes that parasitize the crane fly larvae; this type of treatment may eventually be a reasonable alternative.

Only after trying suitable non-chemical control methods, or determining that the pest outbreak is causing too much serious damage, should chemical controls be considered. Study to determine what products are available and choose a product that is the least toxic and has the least non-target impact. Refer to the Operational BMPs for the use of Pesticides below for guidelines on choosing, storing, and using lawn and garden chemicals.

**Step 6. Evaluate and record the effectiveness of the control, and modify maintenance practices to support lawn or landscape recovery and prevent recurrence.**

Keep records! Note when, where, and what symptoms occurred, or when monitoring revealed a potential pest problem. Note what controls were applied and when, and the effectiveness of the control. Monitor next year for the same problems. Review your landscape maintenance and cultural practices to see if they can be modified to prevent or reduce the problem.

A comprehensive IPM Program should also include the proper use of pesticides as a last resort, and vegetation/fertilizer management to eliminate or minimize the contamination of stormwater.

**This Page Intentionally Left Blank**

## Appendix D Management of Street Wastes

### D.1 Street Waste Liquids

Street waste collection should emphasize retention of solids over liquids. Street waste solids are the principal objective in street waste collection, and are easier to store and treat than liquids.

Street waste liquids require treatment before discharge. Street waste liquids usually contain high amounts of suspended, total solids and adsorbed metals. Treatment requirements depend on the discharge location.

Discharges to sanitary sewer and storm sewer systems must be approved by City of Tacoma Source Control.

The following order of preference for disposal of catch basin decant liquid and water removed from stormwater treatment facilities is required.

1. Discharge of catch basin liquids to the City of Tacoma municipal sanitary sewer system. Discharges may require a Special Approved Discharge (SAD) Permit from City of Tacoma Source Control. Call 253-591-5588 for additional information on SAD permits.
2. Discharge of catch basin decant liquids may be allowed into a basic or enhanced stormwater treatment BMP, only if option 1 is not feasible. Decant liquid may be discharged back into the storm system under the following conditions:
  - Discharge to the sanitary sewer is not feasible, and
  - Discharge is to a basic or enhanced stormwater treatment facility, and
  - The discharge is as near to the treatment facility as practical, and
  - The storm system owner has granted approval and has determined that the treatment facility will accommodate the increased loading.

Visible sheen is not permitted to be discharged. If decant water contains visible sheen, additional treatment is required.

Flocculants for the pretreatment of decant liquid must be non-toxic under the circumstances of use and must be approved in advance by the Washington State Department of Ecology.

3. Water removed from stormwater BMPs that are intended to impound water as part of their function may be returned to the stormwater system. The following conditions apply:
  - Clean water removed from a stormwater treatment structure may be discharged directly to a downgradient cell of a treatment facility, or into the storm sewer system.
  - Turbid water may be discharged back into the facility it was removed from if:
    - The removed water has been stored in a clean container, and
    - There will be no discharge from the treatment structure for at least 24 hours.
  - The discharge must be approved by the facility owner.



## **D.2 Street Waste Solids**

Street waste is a solid waste. Contact the City of Tacoma Solid Waste Section at 253-591-5543 for information on solid waste disposal. The following guidelines should be followed for handling solid street waste:

- Street waste that is suspected to be a hazardous or dangerous waste should not be collected with other street waste.
- Spills should be handled by trained professionals. Contact the City of Tacoma Source Control for additional information on spills at 253-591-5588.
- Street waste may require testing to determine its disposal requirements.

# Table of Contents

## Volume 5 - Water Quality Treatment BMPs

<b>Chapter 1 Treatment Facility Selection Process</b> .....	<b>5-3</b>
1.1 Step-by-Step Selection Process for Treatment Facilities .....	5-3
<b>Chapter 2 Treatment Facility Menus</b> .....	<b>5-7</b>
2.1 Oil Control Menu .....	5-7
2.1.1 Performance Goal .....	5-7
2.1.2 Options .....	5-7
2.1.3 Application on the Project Site .....	5-8
2.2 Phosphorus Treatment Menu .....	5-8
2.2.1 Performance Goal .....	5-8
2.2.2 Options .....	5-8
2.3 Enhanced Treatment Menu .....	5-9
2.3.1 Performance Goal .....	5-9
2.3.2 Options .....	5-9
2.4 Basic Treatment Menu .....	5-10
2.4.1 Performance Goal .....	5-10
2.4.2 Options .....	5-10
<b>Chapter 3 General Requirements for Stormwater Facilities</b> .....	<b>5-13</b>
3.1 Design Flow Volume and Flow Rate .....	5-13
3.1.1 Water Quality Design Flow Volume .....	5-13
3.1.2 Water Quality Design Flow Rate .....	5-13
3.1.3 Flows Requiring Treatment .....	5-14
3.1.4 Rounding .....	5-14
3.2 Sequence of Facilities .....	5-14
3.3 Setbacks .....	5-15
3.4 Easements, Access, and Dedicated Tracts .....	5-16
3.5 Materials .....	5-16
3.6 Maintenance of Stormwater Facilities .....	5-16
<b>Chapter 4 Facility Liners</b> .....	<b>5-17</b>
4.1 General Design Criteria .....	5-17
4.2 Design Criteria for Low Permeability Liner Options .....	5-19
4.2.1 Compacted Till Liners .....	5-19
4.2.2 Clay Liners .....	5-19
4.2.3 Geomembrane Liners .....	5-19
4.2.4 Concrete Liners .....	5-20
4.2.5 Treatment Liners .....	5-20
<b>Chapter 5 Hydraulic Structures</b> .....	<b>5-21</b>
5.1 Flow Splitter Designs .....	5-21
5.1.1 General Design Criteria .....	5-21
5.1.2 Materials .....	5-21
5.1.3 Maintenance .....	5-22

- 5.2 Flow Spreading Options . . . . . 5-24
  - 5.2.1 General Design Criteria . . . . . 5-25
  - 5.2.2 Maintenance . . . . . 5-29
- Chapter 6 Pretreatment . . . . . 5-31**
  - 6.1 Purpose. . . . . 5-31
  - 6.2 Application. . . . . 5-31
  - 6.3 Best Management Practices (BMPs) for Pretreatment . . . . . 5-31
    - 6.3.1 BMP T610 Presettling Basin . . . . . 5-31
- Chapter 7 Infiltration Treatment Facilities . . . . . 5-33**
  - 7.1 Purpose. . . . . 5-33
  - 7.2 Application. . . . . 5-33
  - 7.3 Design Methodology . . . . . 5-33
    - 7.3.1 Select a location . . . . . 5-33
    - 7.3.2 Estimate volume of stormwater, Vdesign . . . . . 5-33
    - 7.3.3 Develop trial infiltration facility geometry . . . . . 5-33
    - 7.3.4 Complete a more detailed site characterization study and consider site suitability criteria . . . . . 5-33
    - 7.3.5 Determine the infiltration rate . . . . . 5-34
    - 7.3.6 Size the facility. . . . . 5-34
    - 7.3.7 Construction Criteria . . . . . 5-35
    - 7.3.8 Maintenance Criteria . . . . . 5-35
    - 7.3.9 Verification Testing of the Completed Facility . . . . . 5-35
  - 7.4 Site Characterization Criteria . . . . . 5-35
    - 7.4.1 Surface Features Characterization . . . . . 5-36
    - 7.4.2 Subsurface Characterization . . . . . 5-36
    - 7.4.3 Infiltration Rate Determination . . . . . 5-36
    - 7.4.4 Soil Testing . . . . . 5-37
    - 7.4.5 Infiltration Receptor . . . . . 5-37
  - 7.5 Design Saturated Hydraulic Conductivity – Guidelines and Criteria . . . . . 5-38
    - 7.5.1 Large Scale Pilot Infiltration Test (PIT) . . . . . 5-38
    - 7.5.2 Small Scale Pilot Infiltration Test (PIT) . . . . . 5-39
    - 7.5.3 Soil Grain Size Analysis Method . . . . . 5-41
    - 7.5.4 Correction Factors . . . . . 5-42
  - 7.6 Site Suitability . . . . . 5-43
    - 7.6.1 Setback Criteria . . . . . 5-44
    - 7.6.2 Groundwater Protection Areas . . . . . 5-44
    - 7.6.3 High Vehicle Traffic Areas . . . . . 5-44
    - 7.6.4 Soil Infiltration Rate/Drawdown Time for Treatment . . . . . 5-45
    - 7.6.5 Depth to Bedrock, Water Table, or Impermeable Layer . . . . . 5-45
    - 7.6.6 Soil Physical and Chemical Suitability for Treatment . . . . . 5-45
    - 7.6.7 Seepage Analysis and Control . . . . . 5-46
    - 7.6.8 Cold Climate and Impact of Roadway Deicers . . . . . 5-46
  - 7.7 Best Management Practices (BMPs) for Infiltration Treatment. . . . . 5-47
    - 7.7.1 Design Criteria for Infiltration Facilities . . . . . 5-47
    - 7.7.2 BMP T710 Infiltration Basins . . . . . 5-48
    - 7.7.3 BMP T720 Infiltration Trenches . . . . . 5-49

**Chapter 8 Sand Filtration Treatment Facilities . . . . . 5-53**

    8.1 Purpose. . . . . 5-53

    8.2 Description . . . . . 5-53

    8.3 Applications and Limitations . . . . . 5-58

    8.4 Site Suitability . . . . . 5-58

    8.5 Design Criteria . . . . . 5-58

        8.5.1 Sand Filter Design Criteria and Sizing . . . . . 5-58

    8.6 Construction Criteria . . . . . 5-61

    8.7 Maintenance Criteria . . . . . 5-61

    8.8 BMP T808 Basic Sand Filter . . . . . 5-61

    8.9 BMP T809 Large Sand Filter . . . . . 5-61

        8.9.1 Additional Large Sand Filter Design Criteria . . . . . 5-61

    8.10 BMP T810 Sand Filter Vault . . . . . 5-62

        8.10.1 Description (Figure 5 - 13 and Figure 5 - 14) . . . . . 5-62

        8.10.2 Applications and Limitations . . . . . 5-62

        8.10.3 Additional Design Criteria for Vaults . . . . . 5-62

    8.11 BMP T820 Linear Sand Filter . . . . . 5-65

        8.11.1 Description. . . . . 5-65

        8.11.2 Application and Limitations . . . . . 5-65

        8.11.3 Additional Design Criteria for Linear Sand Filters . . . . . 5-65

**Chapter 9 Media Filter Drain (previously Ecology Embankment) – BMP T900 . . . . . 5-67**

**Chapter 10 Biofiltration Treatment Facilities . . . . . 5-69**

    10.1 Purpose. . . . . 5-69

    10.2 Applications. . . . . 5-69

    10.3 Site Suitability . . . . . 5-69

    10.4 Best Management Practices . . . . . 5-69

        10.4.1 BMP T1010 Basic Biofiltration Swale . . . . . 5-70

        10.4.2 BMP T1020 Wet Biofiltration Swale. . . . . 5-86

        10.4.3 BMP T1030 Continuous Inflow Biofiltration Swale . . . . . 5-88

        10.4.4 BMP T1040 Basic Filter Strip . . . . . 5-89

        10.4.5 BMP T1050: Compost-Amended Vegetated Filter Strip (CAVFS) . . . . . 5-93

**Chapter 11 Wetpool Facilities . . . . . 5-97**

    11.1 Purpose. . . . . 5-97

    11.2 Best Management Practices . . . . . 5-97

        11.2.1 BMP T1110 Wetponds - Basic and Large . . . . . 5-97

        11.2.2 BMP T1120 Wetvaults . . . . . 5-107

        11.2.3 BMP T1130 Stormwater Treatment Wetlands . . . . . 5-112

        11.2.4 BMP T1140 Combined Detention and Wetpool Facilities . . . . . 5-118

    11.3 Combined Detention and Wetvault . . . . . 5-121

    11.4 Combined Detention and Stormwater Wetland . . . . . 5-123

        11.4.1 Sizing Criteria . . . . . 5-123

        11.4.2 Design Criteria. . . . . 5-123

        11.4.3 Inlet and Outlet Criteria . . . . . 5-123

        11.4.4 Planting Requirements . . . . . 5-123

**Chapter 12 Oil Water Separators . . . . . 5-125**

12.1 Purpose . . . . .5-125

12.2 Description . . . . .5-125

12.3 Applications/Limitations. . . . .5-125

12.4 Site Suitability . . . . .5-128

12.5 Design Criteria . . . . .5-129

    12.5.1 General Considerations . . . . .5-129

    12.5.2 Criteria for Baffles . . . . .5-129

    12.5.3 Maintenance . . . . .5-129

12.6 Oil Water Separator BMPs . . . . .5-130

    12.6.1 BMP T1110 API (Baffle type) Separators . . . . .5-130

    12.6.2 BMP T1111 Coalescing Plate (CP) Separators . . . . .5-133

**Chapter 13 Emerging Technologies. . . . .5-135**

    13.1 Background. . . . .5-135

    13.2 Emerging Technology and the City of Tacoma . . . . .5-135

    13.3 Ecology Role in Evaluating Emerging Technologies. . . . .5-135

    13.4 Evaluation of Emerging Technologies. . . . .5-135

    13.5 Assessing Levels of Development of Emerging Technologies . . . . .5-136

    13.6 Examples of Emerging Technologies for Stormwater Treatment and Control . . . . .5-137

    13.7 Maintenance . . . . .5-137

**Appendix A Basic Treatment Receiving Waters . . . . .5-139**

**Appendix B Geotextile Specifications . . . . .5-141**

    B.1 Applications . . . . .5-142

**Appendix C Turbulence and Short-Circuiting Factor. . . . .5-143**

**Appendix D South Tacoma Groundwater Protection District Infiltration Policy . . . . .5-145**

**Appendix E Compost Specifications . . . . .5-151**



# Water Quality Treatment BMPs

## Purpose of this Volume

This volume focuses on treatment of runoff to remove pollutants at developed sites. Typical pollutants of concern include sand, silt, and other suspended solids; metals such as copper, lead, and zinc; nutrients (e.g., nitrogen and phosphorous); certain bacteria and viruses; and organics such as petroleum hydrocarbons and pesticides. Methods of pollutant removal include sedimentation/settling, filtration, infiltration, plant uptake, ion exchange, adsorption, and bacterial decomposition. Floatable pollutants such as oil, debris, and scum can be removed with separator structures. The purpose of this volume is to provide criteria for selection and design of permanent runoff treatment facilities.

Use this volume to select permanent water quality treatment BMPs. Include the BMPs and the design criteria used in your Stormwater Site Plan (see Volume 1). This volume should be used as an aid in designing and constructing water quality treatment BMPs.

## Content and Organization of this Volume

Volume 5 contains 10 chapters and 4 appendices:

- Chapter 1 outlines a step-by-step process for selecting treatment facilities for new development and redevelopment projects.
- Chapter 2 presents treatment facility “menus” that are used in applying the step-by-step process presented in Chapter 1. These menus cover different treatment needs that are associated with different sites.
- Chapter 3 discusses general requirements for treatment facilities.
- Chapters 4 - 12 provide guidance for the design of facilities.
- The appendices provide more detailed information on selected topics referenced in the preceding chapters.

**This Page Intentionally Left Blank**

# Chapter 1 Treatment Facility Selection Process

This chapter describes a step-by-step process for selecting the type of treatment facilities that will apply to individual projects.

## 1.1 Step-by-Step Selection Process for Treatment Facilities

Use the step-by-step process outlined below to determine the type of treatment facilities applicable to the project.

**Step 1. Determine the receiving waters and pollutants of concern**

**Step 2. Determine if oil treatment is required**

**Step 3. Determine if infiltration for pollutant removal is possible**

**Step 4. Determine if pretreatment is required**

**Step 5. Determine if control of phosphorus is required**

**Step 6. Determine if enhanced treatment is required**

**Step 7. Determine if basic treatment is required**

**Step 8. Consider other factors that may influence the selection of a treatment facility**

**Step 9. Select an appropriate treatment facility or treatment train for each type of treatment required**

### Step 1: Determine the Receiving Waters and Pollutants of Concern Based on Offsite Analysis

The project proponent must determine the natural receiving water for the stormwater drainage from the project site (groundwater, wetland, lake, stream, or salt water). This is necessary to determine the applicable treatment menu from which to select treatment facilities. If the discharge is to the City of Tacoma's municipal storm drainage system, the applicant must determine the final discharge point. Watershed specific requirements and/or specific protection areas are outlined in Chapter 2 of Volume 1.

The Puyallup River and Puget Sound are considered Basic Treatment Receiving Waters. If the thresholds for enhanced treatment are met for discharges to the Puyallup River or Puget Sound, enhanced treatment will not be required, but basic water quality treatment, oil treatment, and phosphorus treatment will be required if the thresholds are met. Discharges to sensitive areas as defined in Volume 1 may require enhanced treatment even if they are located in the Puyallup River or Puget Sound.

### Step 2: Determine if an Oil Control Facility/Device is Required

Oil control is required for projects that have **high-use sites**. **High-use sites** are those that typically generate high concentrations of oil due to high traffic turnover or the frequent transfer of oil. **High-use sites** include:

- An area of a commercial or industrial site subject to an expected average daily traffic (ADT) count equal to or greater than 100 vehicles per 1,000 square feet of gross building area;
- An area of a commercial or industrial site subject to petroleum storage and transfer in excess of 1,500 gallons per year, not including routinely delivered heating oil (includes gasoline service stations);



- An area of a commercial or industrial site subject to parking, storage or maintenance of 25 or more motorized vehicles that are over 10 tons gross weight (trucks, buses, trains, heavy equipment, etc.);
- A road intersection with a measured ADT count of 25,000 vehicles or more on the main roadway and 15,000 vehicles or more on any intersecting roadway, excluding projects proposing primarily pedestrian or bicycle use improvements.

The traffic count can be estimated using information from “Trip Generation” published by the Institute of Transportation Engineers, or from a traffic study prepared by a professional engineer or transportation specialist with experience in traffic estimation.

In general, all-day parking areas are not intended to be defined as **high-use sites**, and should not require oil control treatment outlined in Section 2.1.

**NOTE:** Some land use types require the use of a spill control (SC-type) oil/water separator. Those situations are described in Volume 4 and are separate from this oil treatment requirement.

If an oil control facility is required, select an appropriate oil control facility for the project. Proceed to Step 3.

### **Step 3: Determine if Infiltration for Pollutant Removal is Possible**

Use Volume 5, Chapter 7 as a guide to determine if the site contains soils that are conducive to infiltration and suitable for treatment.

Private infiltration facilities used in the South Tacoma Groundwater Protection District (STGPD) that receive stormwater from pollution-generating surfaces may be allowed on a case-by-case basis and are subject to additional treatment and monitoring.

The City of Tacoma Public Works Department and Tacoma-Pierce County Health Department developed a guidance document that provides the circumstances and requirements for approval of infiltration facilities for managing pollution-generating stormwater runoff in the STGPD. The document, “Implementation of Stormwater Infiltration for Pollution-Generating Surfaces in the South Tacoma Groundwater Protection District” is available in Volume 5, Appendix D and at [www.cityoftacoma.org/stormwater](http://www.cityoftacoma.org/stormwater).

Infiltration facilities that are used for treatment must be preceded by a pretreatment facility to reduce the occurrence of plugging. Any of the basic treatment facilities, and detention ponds designed to meet flow control requirements, can also be used for pretreatment. If an oil/water separator is necessary for oil control, it can also function as the pre-settling basin as long as the influent suspended solids concentrations are not high. However, frequent inspections are necessary to determine when accumulated solids exceed the 6-inch depth at which clean-out is recommended.

If infiltration is practicable, select and apply pretreatment and an infiltration facility. Apply oil treatment and phosphorus treatment as applicable.

### **Step 4: Determine if Pretreatment is Required**

- Pretreatment is required prior to sand filtration and water quality infiltration BMPs to protect them from excessive siltation and debris;
- Where the proposed treatment facility may be adversely affected by a pollutant load. Environmental Services will make the final determination if pretreatment is required.

If a pretreatment facility is required, select an appropriate pretreatment facility for the project. Proceed to Step 5.

### **Step 5: Determine if Phosphorus Treatment is Required**

Phosphorus control requirements are identified as a basin requirement in Volume 1, Chapter 2. Currently, direct and indirect discharges to Wapato Lake require phosphorus treatment when thresholds are met.

If phosphorus treatment is required, select an appropriate phosphorus treatment facility for the project. Proceed to Step 6. If phosphorus treatment is not required, proceed directly to Step 6.

### **Step 6: Determine if Enhanced Treatment is Required**

Except as specified under Step 7, enhanced treatment is required for the following land use types that meet the requirements for stormwater treatment and: 1) discharge stormwater directly or indirectly to fresh waters designated for aquatic life use or have an existing aquatic life use; or 2) use infiltration strictly for flow control – not treatment – and the discharge is within ¼ mile of a fresh water designated for aquatic life use or that has an existing aquatic life use:

- Industrial sites,
- Commercial sites,
- Multi-family sites, and
- High AADT roads as follows:
  - Fully controlled and partially controlled limited access highways with Annual Average Daily Traffic (AADT) counts of 15,000 or more
  - All other roads with an AADT of 7,500 or greater

The Puyallup River and Puget Sound are considered Basic Treatment Receiving Waters. If the thresholds for enhanced treatment are met for discharges to the Puyallup River or Puget Sound, enhanced treatment will not be required, but basic water quality treatment, oil treatment, and phosphorus treatment will be required if the thresholds are met. Discharges to sensitive areas as defined in Volume 1 may require enhanced treatment if they are located in the Puyallup River or Puget Sound.

If the project must apply Enhanced Treatment, select and apply an appropriate Enhanced Treatment facility. Please refer to the Enhanced Treatment Menu in Section 2.3. Select an option from the menu after reviewing the applicability and limitations, site suitability, and design criteria of each for compatibility with the site.

If enhanced treatment is not required proceed to step 7

### **Step 7: Select a Basic Treatment Facility**

Basic treatment is required for the following that meet the treatment thresholds of Minimum Requirement #6 and meet one or more of the circumstances:

- Projects not needing oil control, phosphorus treatment, or enhanced treatment.
- Projects that discharge to the ground unless:
  - Infiltration through soils meeting the site suitability for treatment is met and pretreatment is provided.

- Infiltration for flow control only is proposed and the discharge is within ¼ mile of a phosphorus-sensitive lake. In this instance phosphorus control is required but additional basic treatment will not be required.
- The project site is a land use type specified under enhanced treatment and is located within ¼ mile of a fresh water designated for aquatic life use or that has an existing aquatic life use. In this instance enhanced treatment is required but additional basic treatment will not be required.
- Project sites that discharge directly or indirectly to fresh water that is not designated for aquatic life use and does not have an existing aquatic life use.
- Landscaped areas of industrial, commercial, and multifamily project sites.
- Parking lots of industrial and commercial project sites, dedicated solely to parking of employee's private vehicles that do not involve any other pollution-generating sources (e.g. industrial activities, customer parking, storage of erodible or leachable material, wastes or chemicals).

Basic treatment may also be required based on basin specific requirements, see Volume 1, Chapter 2. For developments with a mix of land use types, the Basic Treatment requirement shall apply when the runoff from the areas subject to the Basic Treatment requirement comprises 50% or more of the total runoff within a threshold discharge area.

#### **Step 8: Consider Other Factors that May Influence the Selection of a Treatment Device**

Factors such as soil type, sediment load, native soil type, slope, depth to groundwater or other impermeable layer, setbacks, and depth of facility all must be considered when siting a stormwater treatment BMP. Each BMP contains specific requirements that must be adhered to.

#### **Step 9: Select an Appropriate Treatment Device**

Refer to the treatment facility menus in Volume 5, Chapter 2 for treatment facility options.

## Chapter 2 Treatment Facility Menus

This chapter identifies the treatment facility menus. The menus in this chapter are as follows:

- Oil Control Menu, Volume 5, Section 2.1
- Phosphorus Treatment Menu, Volume 5, Section 2.2
- Enhanced Treatment Menu, Volume 5, Section 2.3
- Basic Treatment Menu, Volume 5, Section 2.4

Performance goals apply to the water quality design storm volume or flowrate, whichever is applicable. The incremental portion of runoff in excess of water quality design flowrate can be routed around the facility (offline treatment facilities) or can be passed through the facility untreated (online treatment facilities) provided a net pollutant reduction is maintained. All performance goals apply to stormwater typically found in Pacific Northwest maritime climates, where long duration, low intensity storms predominate and stormwater contains mostly silt-sized particles.

### 2.1 Oil Control Menu

The facilities in this menu are required in addition to facilities required by other treatment menus.

#### 2.1.1 Performance Goal

The oil control menu facility options are intended to achieve the goals of no ongoing or recurring visible sheen, and to have a 24-hour average Total Petroleum Hydrocarbon (TPH) concentration no greater than 10 mg/l, and a maximum of 15 mg/l for a discrete sample (grab sample).

#### 2.1.2 Options

Oil control options include facilities that are small, treat runoff from a limited area, and require frequent maintenance as well as facilities that treat runoff from larger areas and generally require less frequent maintenance.

- **API-Type Oil/Water Separator** – See Volume 5, Chapter 12
- **Coalescing Plate Oil/Water Separator** – See Volume 5, Chapter 12
- **Linear Sand Filter** – See Volume 5, Chapter 8

The linear sand filter is used in the Basic, Enhanced, and Phosphorus Treatment menus also. If used to satisfy one of those treatment requirements, the same facility shall not also be used to satisfy the oil control requirement unless enhanced maintenance is assured. This is to prevent clogging of the filter by oil so that it will function for suspended solids and other pollutant removal as well. Quarterly cleaning is required when used as a combination facility.

- **Emerging Stormwater Treatment Technologies for Oil Treatment** – See Volume 5, Chapter 13

### 2.1.3 Application on the Project Site

Place oil control facilities upstream of other facilities, as close to the source of oil generation as practical. For high-use sites located within a larger commercial center, only the impervious surface associated with the high-use portion of the site is subject to oil treatment requirements. If common parking for multiple businesses is provided, treatment shall be applied to the number of parking stalls required for the high-use business only. If the treatment collection area also receives runoff from other areas, the treatment facility must be sized to treat all water passing through the facility.

High-use roadway intersections shall treat lanes where vehicles accumulate during the traffic signal cycle, including left and right turn lanes and through lanes, from the beginning of the left turn pocket. If no left turn pocket exists, the treatable area shall begin at a distance equal to three car lengths from the stop line. If runoff from the intersection drains to more than two collection areas that do not combine within the intersection, treatment may be limited to any two of the collection areas.

## 2.2 Phosphorus Treatment Menu

### 2.2.1 Performance Goal

The phosphorus menu facility choices are intended to achieve a goal of 50% total phosphorus removal for a range of influent concentrations between 0.1 – 0.5 mg/l. The phosphorus menu facility choices must achieve basic treatment goals in addition to phosphorus.

### 2.2.2 Options

Any one of the following options may be chosen to satisfy the phosphorus treatment requirement.

- **Infiltration with appropriate pretreatment** – See Volume 5, Chapter 7.
  - ***Infiltration Treatment*** - If infiltration is through soils meeting the minimum site suitability criteria for infiltration treatment (see Chapter 7), a presettling basin or a basic treatment facility can serve for pretreatment.
  - ***Infiltration Preceded by Basic Treatment*** - If infiltration is through soils that do not meet the soil suitability criteria for infiltration treatment, treatment must be provided by a basic treatment facility unless the soil and site fit the description in the next option below.
  - ***Infiltration Preceded by Phosphorus Treatment*** - If the soils do not meet the soil suitability criteria **and** the infiltration site is within ¼ mile of a phosphorus-sensitive receiving water, or a tributary to that water, treatment must be provided by one of the other treatment facility options listed below.
- **Large Sand Filter** – See Volume 5, Chapter 8
- **Large Wetpond** – See Volume 5, Chapter 11
- **Emerging Stormwater Treatment Technologies for Phosphorus Treatment** – See Volume 5, Chapter 13
- **Two-Facility Treatment Trains** – See Volume 5, Table 5 - 1
- **Media Filter Drain** - See Volume 5, Chapter 9

**Table 5 - 1: Treatment Trains for Phosphorus Removal**

First Basic Treatment Facility	Second Treatment Facility
Biofiltration Swale	Basic Sand Filter or Sand Filter Vault
Filter Strip	Linear Sand Filter (no presettling needed)
Linear Sand Filter	Filter Strip
Basic Wetpond	Basic Sand Filter or Sand Filter Vault
Wetvault	Basic Sand Filter or Sand Filter Vault
Stormwater Treatment Wetland	Basic Sand Filter or Sand Filter Vault
Basic Combined Detention and Wetpool	Basic Sand Filter or Sand Filter Vault

## 2.3 Enhanced Treatment Menu

### 2.3.1 Performance Goal

The enhanced treatment facility choices are intended to provide a higher rate of removal of dissolved metals than basic treatment facilities. A higher rate of removal is currently defined as greater than 30% dissolved copper removal and greater than 60% dissolved zinc removal. The performance goal assumes that the facility is treating stormwater with influent dissolved copper ranging from 0.005 to 0.02 mg/l, and dissolved zinc ranging from 0.02 to 0.3 mg/l. Enhanced treatment facilities must achieve basic treatment goals in addition to enhanced treatment goals.

### 2.3.2 Options

Any one of the following options may be chosen to satisfy the enhanced treatment requirement:

- **Infiltration with appropriate pretreatment** – See Volume 5, Chapter 7
  - ***Infiltration Treatment*** - If infiltration is through soils meeting the minimum site suitability criteria for infiltration treatment (see Chapter 7, a presettling basin or a basic treatment facility can serve for pretreatment.
  - ***Infiltration Preceded by Basic Treatment*** - If infiltration is through soils that do not meet the soil suitability criteria for infiltration treatment, treatment must be provided by a basic treatment facility unless the soil and site fit the description in the next option below.
  - ***Infiltration Preceded by Enhanced Treatment*** - If the soils do not meet the soil suitability criteria **and** the infiltration site is within ¼ mile of a fish-bearing stream, a tributary to a fish-bearing stream, or a lake, treatment must be provided by one of the other treatment facility options listed below.
- **Large Sand Filter** – See Volume 5, Chapter 8
- **Stormwater Treatment Wetland** – See Volume 5, Chapter 11
- **Two Facility Treatment Trains** – See Volume 5, Table 5 - 2
- **Compost-Amended Vegetated Filter Strip (CAVFS)** – See Volume 5, Chapter 10
- **Bioretention** – See Volume 5, Volume 6

- **Media Filter Drain** - See Volume 5, Chapter 9
- **Emerging Stormwater Treatment Technologies for Enhanced Treatment** – See Volume 5, Chapter 13

**Table 5 - 2: Treatment Trains for Enhanced Treatment**

First Basic Treatment Facility	Second Treatment Facility
Biofiltration Swale	Basic Sand Filter or Sand Filter Vault or Media Filter <sup>a</sup>
Filter Strip	Linear Sand Filter with no presettling cell needed
Linear Sand Filter	Filter Strip
Basic Wetpond	Basic Sand Filter or Sand Filter Vault or Media Filter <sup>a</sup>
Wetvault	Basic Sand Filter or Sand Filter Vault or Media Filter <sup>a</sup>
Basic Combined Detention/Wetpool	Basic Sand Filter or Sand Filter Vault or Media Filter <sup>a</sup>
Basic Sand Filter or Sand Filter Vault with a presettling cell if the filter isn't preceded by a detention facility	Media Filter <sup>a</sup>

a. The media filter must be of a type approved for basic or enhanced treatment by the Washington State Department of Ecology. Refer to Ecology's website: [www.ecy.wa.gov/programs/wq/stormwater/newtech](http://www.ecy.wa.gov/programs/wq/stormwater/newtech)

## 2.4 Basic Treatment Menu

### 2.4.1 Performance Goal

The basic treatment menu facility options are intended to achieve 80% removal of total suspended solids (TSS) for influent concentrations ranging from 100 to 200 mg/L. For influent concentrations greater than 200 mg/l, a higher treatment goal is appropriate. For influent concentrations less than 100 mg/l, the facilities should achieve an effluent goal of 20 mg/l total suspended solids.

### 2.4.2 Options

Any one of the following options may be chosen to satisfy the basic treatment requirement:

- **Infiltration** – See Volume 5, Chapter 7
- **Sand Filters** – See Volume 5, Chapter 8
- **Biofiltration Swales** – See Volume 5, Chapter 10
- **Vegetated Filter Strips** – See Volume 5, Chapter 10
- **Compost Amended Vegetated Filter Strips (CAVFS)** – See Volume 5, Chapter 10
- **Basic Wetpond** – See Volume 5, Chapter 11

- **Wetvault** – See Volume 5, Chapter 11

A wetvault may be used for commercial, industrial, or road projects if there are space limitations. The use of wetvaults is discouraged for residential projects. Combined detention/wetvaults are allowed.

- **Stormwater Treatment Wetland** – See Volume 5, Chapter 11
- **Combined Detention and Wetpool Facilities** – See Volume 5, Chapter 11
- **Bioretention** – See Volume 6
- **Emerging Stormwater Treatment Technologies for Basic Treatment** – See Volume 5, Chapter 13
- **Media Filter Drain** - See Volume 5, Chapter 9



**This Page is Intentionally Left Blank**

## Chapter 3 General Requirements for Stormwater Facilities

This chapter addresses general requirements for treatment facilities. Requirements discussed in this chapter include design volumes and flows, sequencing of facilities, liners, and hydraulic structures for splitting or dispersing flows.

### 3.1 Design Flow Volume and Flow Rate

#### 3.1.1 Water Quality Design Flow Volume

The volume of runoff predicted from a 24-hour storm with a 6-month return frequency (a.k.a., 6-month, 24-hour storm) obtained from an approved single event model. The 6-month, 24-hour design storm of 1.44 inches shall be used in the City of Tacoma.

Alternatively, the water quality design storm volume shall be equal to the simulated daily volume indicated by WWHM that represents the upper limit of the range of daily volumes that accounts for 91% of the entire runoff volume over a multi-decade period of record.

Treatment facility sizes are the same whether they precede, follow or are incorporated (i.e., combined detention and wetpool facilities) into the detention facility.

Treatment options that can be sized by this method include:

- Wetponds
- Wetvaults
- Stormwater Wetlands
- Combined Detention and Wetpool Facilities

#### 3.1.2 Water Quality Design Flow Rate

**A. Preceding Detention Facilities or when Detention Facilities are not required: The flowrate at or below which 91% of the runoff volume, as estimated by WWHM, will be treated.**

- All BMPs except wetpool type facilities (Chapter 11) shall use the 15-minute time series from WWHM (or other approved model). Design criteria for treatment facilities are assigned to achieve the applicable performance goal (e.g., 80 percent TSS removal) at the water quality design flow rate.
- **Offline facilities:** For treatment facilities not preceded by an equalization or storage basin, and when runoff flow rates exceed the water quality design flow rate, the treatment facility shall continue to receive and treat the water quality design flow rate to the applicable treatment performance goal. The incremental portion of runoff in excess of the water quality design flowrate can be routed around the facility.
- Treatment facilities preceded by an equalization or storage basin may identify a lower water quality design flow rate provided that at least 91 percent of the estimated runoff volume in the time series of WWHM is treated to the applicable performance goals.
- **Online facilities:** Runoff flow rates in excess of the water quality design flow rate can be routed through the facility provided a net pollutant reduction is maintained.

**B. Downstream of Detention Facilities: The full 2-year release rate from the detention facility.**

- WWHM shall identify the 2-year return frequency flow rate discharged by a detention facility that is designed to meet the flow duration standard.
- Treatment facilities downstream of detention can be designed online or offline. For offline facilities, the entire water quality design flow volume/rate must be treated. Only flows in excess of the design flow may be bypassed.

### 3.1.3 Flows Requiring Treatment

Runoff from pollution-generating hard or pervious surfaces exceeding the thresholds outlined in Minimum Requirement #6 (Volume 1, Chapter 2) must be treated using the water quality facilities in this volume. If runoff from non-pollution generating surfaces flows into a runoff treatment BMP, flows from those areas must be included in the sizing calculations for the facility. Once runoff from non-pollution generating areas is mixed with runoff from pollution-generating areas, it cannot be separated before treatment.

Stormwater treatment facilities installed to provide treatment of pollution generating surfaces for street sections within the right-of-way shall size those facilities for fully developed conditions to include existing onsite drainage which may connect to the City system if it not currently connected. The onsite fully developed condition assumed to reach the facility shall be derived from the following percentages of impervious area:

- In commercial areas, the percent impervious shall be 85%.
- In industrial areas, the percent impervious shall be 70%.
- In residential areas, the percent impervious shall be 60%.

If an applicant proposes to connect and convey onsite stormwater discharges to the City system the applicant shall ensure that any existing stormwater facilities are appropriately sized for the additional flow. If the facilities are not sized to handle additional stormwater discharges; modification to the facility or onsite treatment may be required to mitigate for the proposed impact.

### 3.1.4 Rounding

Values shall typically be rounded to the nearest 100th for stormwater facility design or when determining which minimum requirements apply to a project. Environmental Services will make the final determination for appropriate rounding.

## 3.2 Sequence of Facilities

Treatment facilities can be placed in a variety of configurations. Some are required to be upstream from detention facilities while others may perform better if located downstream. Detention facilities can act as settling basins and therefore can reduce the load going to a treatment facility. Additionally, treatment facilities can be sequenced together to provide a higher level of treatment that could be achieved by a single facility. For instance, the enhanced treatment and phosphorus removal menus, described in Chapter 2, include treatment options in which more than one type of treatment facility is used. For these treatment trains the sequencing is prescribed.

Table 5 - 3 summarizes placement considerations of treatment facilities in relation to detention facilities.

**Table 5 - 3: Treatment Facility Placement in Relation to Detention Facilities**

Water Quality Facility	Preceding Detention	Following Detention
Basic biofiltration swale (Chapter 10)	OK	OK. Prolonged flows may reduce grass survival. Consider wet biofiltration swale.
Wet biofiltration swale (Chapter 10)	OK	OK
Filter strip (Chapter 10)	OK	No—must be installed before flows concentrate.
Basic or large wetpond (Chapter 11)	OK	OK—less water level fluctuation in ponds downstream of detention may improve aesthetic qualities and performance.
Wetvault (Chapter 11)	OK	OK
Basic or large sand filter or sand filter vault (Chapter 8)	OK, but presettling and control of floatables needed	OK—sand filters downstream of detention facilities may require field adjustments if prolonged flows cause sand saturation and interfere with phosphorus removal.
Stormwater treatment wetland/pond (Chapter 11)	OK	OK—less water level fluctuation and better plant diversity are possible if the stormwater wetland is located downstream of the detention facility.

### 3.3 Setbacks

Setback requirements are generally required by the City of Tacoma Municipal Code, Uniform Building Code, the Tacoma Pierce County Health Department, or other state regulations. Where a conflict between setbacks occurs, the City shall require compliance with the most stringent of the setback requirements from the various codes/regulations. The following are the minimum setbacks required per this manual.

Additional setbacks may be required by other local, state, or federal agencies. See the individual BMPs for BMP specific setback criteria.

- At least 100 feet from drinking water wells, and springs used for public water supplies. Infiltration facilities, unlined wetponds, and detention ponds upgradient of drinking water wells and within 1, 5, and 10-year time of travel zones must comply with Health Department requirements (Washington Wellhead Protection Program, DOH, Publication #331-018).
- All systems shall be at least 10 feet from any building structure and at least 5 feet from any other structure or property line unless approved in writing by Environmental Services. If necessary, setbacks shall be increased from the minimum 10 feet in order to maintain a 1H:1V side slope for future excavation and maintenance. Vertical pond walls may necessitate an increase in setbacks.
- Facility discharge points and infiltration facilities shall be a minimum of 50 feet from the top of any steep (greater than 15%) slope. A geotechnical analysis must be prepared

addressing impacts to facilities proposed within 50 feet of a steep (greater than 15%) slope. More stringent setbacks may be required based upon other portions of Tacoma Municipal Code.

- At least 10 feet from septic tanks and septic drainfields. Shall not be located upstream of residential septic systems unless topography or a hydrologic analysis clearly indicates that subsurface flows will not impact the drainfield.
- Environmental Services may require additional setbacks or analysis for infiltration facilities and unlined wetponds proposed to be sited within the influence of known contaminated sites or abandoned landfills.

Additional setbacks for specific stormwater facilities will be noted in the appropriate section.

### **3.4 Easements, Access, and Dedicated Tracts**

See Volume 3, Chapter 13 for access and easement requirements.

### **3.5 Materials**

Acceptable materials for stormwater facilities include plastics, iron, aluminum, stainless steel and concrete. Zinc galvanized materials are prohibited. Galvanized metal pipes may only be used if they employ a protective asphalt coating.

### **3.6 Maintenance of Stormwater Facilities**

Per Minimum Requirement #9, an operation and maintenance plan shall be prepared for all stormwater management facilities. See Volume 1, Appendix C for specific maintenance requirements for various stormwater treatment facilities and structures that may be a part of the overall stormwater facility. If a device is not included in Volume 1, Appendix C, the requirements of Minimum Requirement #9 must still be met and a maintenance plan shall be developed independently for the device. Maintenance shall be a basic consideration in design and cost-determination of the stormwater management facility.

Any standing water removed during maintenance operation must be disposed of in a City approved manner. See the dewatering requirements in Volume 4, Appendix D of this manual. Pretreatment may be necessary. Solids must be disposed of in accordance with state and local waste regulations.

Facilities shall be designed and constructed such that the facility can be safely and easily inspected by one person and safely and easily maintained. This may require construction of additional inspection ports or access manholes to allow inspection access to be opened by one person.

## Chapter 4 Facility Liners

Liners are intended to reduce the likelihood that pollutants in stormwater will reach groundwater. Where necessary, a liner is incorporated into the base of the treatment facility as the facility is constructed. In addition to groundwater protection considerations, some facility types require permanent water for proper functioning. An example is the first cell of a wetpond.

### 4.1 General Design Criteria

- Check each BMP to determine if a liner is required or recommended.
  - Table 5 - 4 shows recommendations for the type of liner generally best suited for use with various runoff treatment facilities.
  - Liners shall be evenly placed over the bottom and/or sides of the treatment area of the facility as indicated in Table 5 - 4. Areas above the treatment volume that are required to pass flows greater than the water quality treatment flow (or volume) need not be lined. However, the lining must be extended to the top of the interior side slope and anchored if it cannot be permanently secured by other means. See Volume 5, Section 11.2.3.6 for liner requirements specific to wetpool facilities.
  - For low permeability liners, the following criteria apply:
    - Where the seasonal high groundwater elevation is likely to contact a low permeability liner, liner buoyancy may be a concern. A low permeability liner shall not be used in this situation unless evaluated and recommended by a geotechnical engineer.
    - Where grass must be planted over a low permeability liner per the facility design, a minimum of 6 inches of good topsoil or compost-amended native soil (2 inches compost tilled into 6 inches of native till soil) must be placed over the liner in the area to be planted. Twelve inches of cover is preferred. Compost shall:
      - Meet the definition for “composted material” per WAC 173-350-100 and comply with standards in WAC 173-350-220, except the feedstock may contain biosolids or manure feedstocks.
      - Have no visible water or dust during handling.
      - Have soil organic matter content of 40% to 65%.
      - Have a carbon to nitrogen ratio below 25:1. Carbon to nitrogen ratio may be as high as 35:1 for plantings composed entirely of plants native to the Puget Sound Lowlands region.
- Compost specifications can also be found in Volume 5, Appendix E.
- Check all liners for buoyancy stability and include calculations in project documentation. Provide anchors as needed.
  - If a treatment liner will be below the seasonal high water level, the pollutant removal performance of the liner must be evaluated by a geotechnical or groundwater specialist and found to be as protective as if the liner were above the level of the groundwater.

**Table 5 - 4: Lining Types Recommended for Runoff Treatment Facilities**

WQ Facility	Area to be Lined	Type of Liner Recommended
Presetting basin	Bottom and sides	Low permeability liner or Treatment liner (If the basin will intercept the seasonal high groundwater table, a treatment liner is recommended.)
Wetpond	First cell: bottom and sides to WQ design water surface	Low permeability liner or Treatment liner (If the wet pond will intercept the seasonal high groundwater table, a treatment liner is recommended.)
	Second cell: bottom and sides to WQ design water surface	Treatment liner
Combined detention/WQ facility	First cell: bottom and sides to WQ design water surface	Low permeability liner or treatment liner (If the facility will intercept the seasonal high groundwater table a treatment liner is recommended.)
	Second cell: bottom and sides to WQ design water surface	Treatment liner
Stormwater wetland	Bottom and sides, both cells	Low permeability liner (If the facility will intercept the seasonal high groundwater table, a treatment liner is recommended.)
Sand filtration basin	Basin sides only	Treatment liner
Sand filter vault	Not applicable	No liner needed
Linear sand filter	Not applicable if in vault Bottom and sides of presettling cell if not in vault	No liner needed Low permeability or treatment liner
Media filter (in vault)	Not applicable	No liner needed
Wet vault	Not applicable	No liner needed

## 4.2 Design Criteria for Low Permeability Liner Options

This section presents the design criteria for each of the following four low permeability liner options: compacted till liners, clay liners, geomembrane liners, and concrete liners.

### 4.2.1 Compacted Till Liners

- Liner thickness shall be 18 inches after compaction.
- Soil shall be compacted to 95% minimum dry density, modified proctor method (ASTM D-1557).
- Soil shall be placed in 6-inch lifts.
- Reference Table 5 - 5 for Acceptable Gradation for Compacted Till Liners.

**Table 5 - 5: Acceptable Gradation for Compacted Till Liners**

Sieve Size	Percent Passing
6-inch	100
4-inch	90
#4	70 - 100
#200	20

- Other combinations of thickness and density sufficient to retard the infiltration rate to  $2.4 \times 10^{-5}$  inches per minute may be used instead of the above criteria. Environmental Services will require a soils report or other documentation to verify that the proposed depth and compaction of the media is sufficient.

### 4.2.2 Clay Liners

- Liner thickness shall be 12 inches.
- Clay shall be compacted to 95% minimum dry density, modified proctor method (ASTM D-1557).
- Other combinations of thickness and density sufficient to retard the infiltration rate to  $2.4 \times 10^{-5}$  inches per minute may be used instead of the above criteria for compacted till liners. Environmental Services will require a soils report or other documentation to verify that the proposed depth and compaction of the media is sufficient.
- The slope of clay liners must be restricted to 3H: 1V for all areas requiring soil cover; otherwise, the soil layer must be stabilized by another method so that soil slippage into the facility does not occur. Any alternative soil stabilization method must take maintenance access into consideration.
- Where clay liners form the sides of ponds, the interior side slope shall not be steeper than 3H:1V, irrespective of fencing.

### 4.2.3 Geomembrane Liners

- Geomembrane liners shall be ultraviolet (UV) light resistant and have a minimum thickness of 30 mils. A thickness of 40 mils shall be used in areas of maintenance access or where heavy machinery must be operated over the membrane.
- Geomembranes shall be bedded according to the manufacturer's recommendations.



- Liners shall be installed so that they can be covered with 12 inches of top dressing forming the bottom and sides of the water quality facility, except for linear sand filters. Top dressing shall consist of 6 inches of crushed rock covered with 6 inches of native soil. The rock layer is to mark the location of the liner for future maintenance operations. As an alternative to crushed rock, 12 inches of native soil may be used if orange plastic “safety fencing” or another highly-visible, continuous marker is embedded 6 inches above the membrane.
- If possible, liners should be of a contrasting color so that maintenance workers are aware of any areas where a liner may have become exposed when maintaining the facility.
- Geomembrane liners shall not be used on slopes steeper than 5H:1V to prevent the top dressing material from slipping. Textured liners may be used on slopes up to 3H:1V upon recommendation by a geotechnical engineer that the top dressing will be stable for all site conditions, including maintenance.

#### **4.2.4 Concrete Liners**

- Portland cement liners are allowed irrespective of facility size, and shotcrete may be used on slopes. However, specifications must be developed by a professional engineer who certifies the liner against cracking or losing water retention ability under expected conditions of operation, including facility maintenance operations. Weight of maintenance equipment can be up to 80,000 pounds when fully loaded.
- Asphalt concrete may not be used for liners due to its permeability to many organic pollutants.
- If grass is to be grown over a concrete liner, slopes must be no steeper than 5H:1V to prevent the top dressing material from slipping.

#### **4.2.5 Treatment Liners**

The following criteria apply for treatment liners:

- Depth of liner shall be 2 feet.
- Organic content shall be a minimum of 1%. Organic content shall be measured on a dry weight basis using ASTM D2974.
- Cation exchange capacity shall be a minimum of 5 millequivalents/100 grams. Cation exchange shall be tested using EPA lab method 9081.
- The treatment liner shall have an infiltration of 2.4 inches per hour or less.
- If native soils are proposed to be used for the treatment liner, one sample per 1,000 square feet of facility area shall be tested. Each sample shall be a composite of subsamples taken throughout the depth of the soil log for the proposed treatment layer. Testing shall be performed by a professional geologist or similar professional licensed in Washington state.
- Certification by a soils testing laboratory that imported soil meets the organic content and CEC criteria is required.

## Chapter 5 Hydraulic Structures

### 5.1 Flow Splitter Designs

#### 5.1.1 General Design Criteria

- A flow splitter must be designed to deliver the WQ design flow rate specified in this volume to the WQ treatment facility.
- The top of the weir must be located at the water surface for the design flow. Remaining flows enter the bypass line. Flows modeled using a WWHM shall use 15-minute time steps.
- The maximum head must be minimized for flow in excess of the WQ design flow. Specifically, flow to the WQ facility at the 100-year water surface must not increase the design WQ flow by more than 10%.
- A backwater analysis of the existing or proposed conveyance system may be required by Environmental Services.
- Design as shown in Figure 5 - 1 or Figure 5 - 2 or provide an equivalent design.
- Only baffle wall type flow splitters may be used for oil treatment BMPs.
- As an alternative to using a solid top plate in Figure 5 - 2, a full tee section may be used with the top of the tee at the 100-year water surface. This alternative would route emergency overflows (if the overflow pipe were plugged) through the WQ facility rather than back up from the manhole.
- Special applications, such as roads, may require the use of a modified flow splitter. The baffle wall may be fitted with a notch and adjustable weir plate to proportion runoff volumes other than high flows.
- For ponding facilities, backwater effects must be considered in the design of the flow splitter.
- Ladder or step and handhold access must be provided. If the weir wall is higher than 36 inches, two ladders, one to either side of the wall, must be used.
- See Volume 3, Section 7.5 for orifice and weir design equations.
- City of Tacoma owned flow splitters shall have concentric cones when feasible. Access shall be provided to the entire flow splitter for maintenance.

#### 5.1.2 Materials

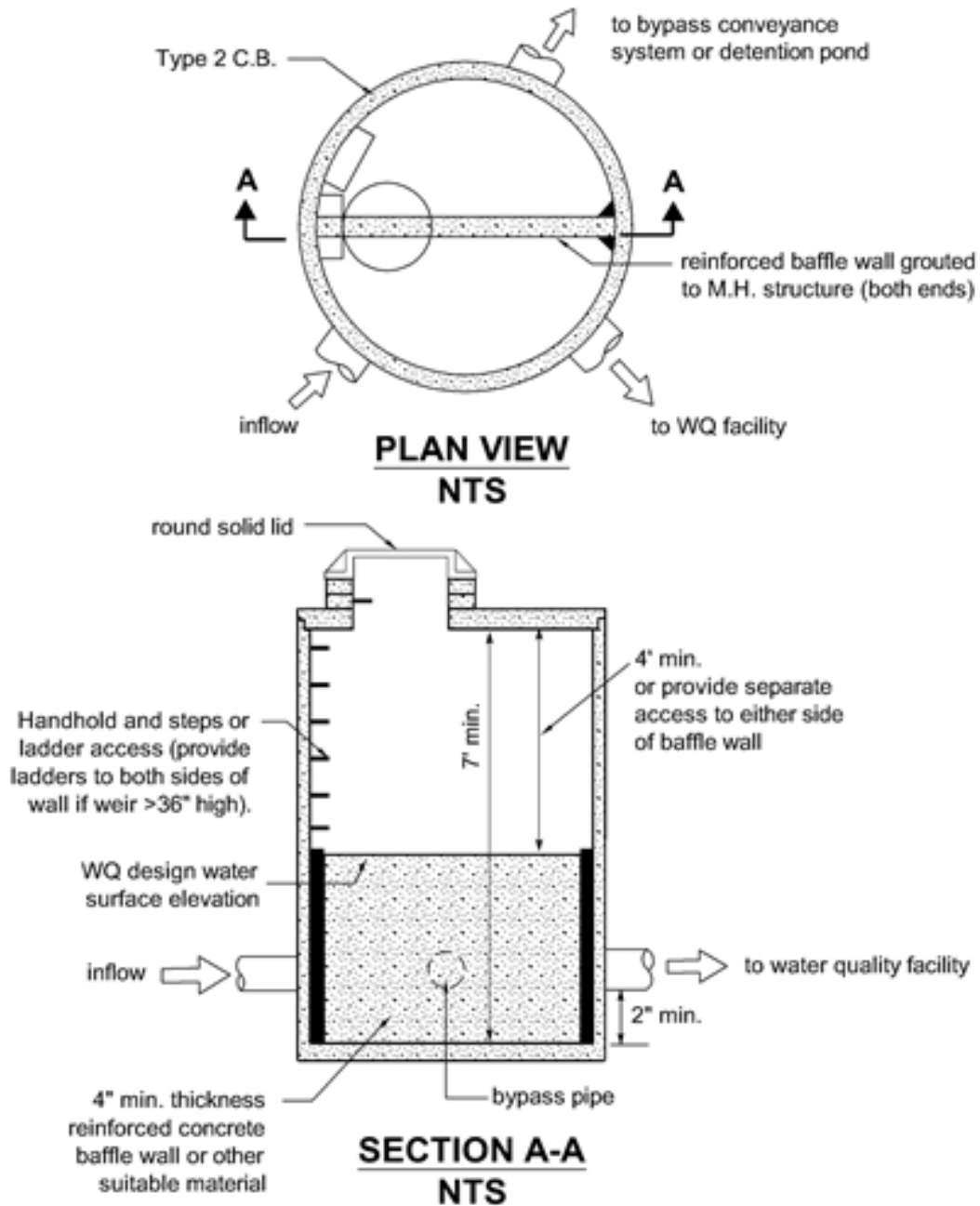
- The splitter baffle may be installed in a Type 2 manhole or vault.
- The baffle wall must be made of reinforced concrete or another suitable material resistant to corrosion, and have a minimum 4-inch thickness. The minimum clearance between the top of the baffle wall and the bottom of the manhole cover must be 4 feet; otherwise, dual access points shall be provided.
- All metal parts must be corrosion resistant. Examples of preferred materials include aluminum, stainless steel, and plastic. Zinc and galvanized materials are prohibited unless coated as approved by Environmental Services. Painted metal parts shall not be used because of poor longevity.

### **5.1.3 Maintenance**

Per Minimum Requirement #9, an operation and maintenance plan shall be prepared for all stormwater management facilities. See Volume 1, Appendix C, Maintenance Checklist #5 for specific maintenance requirements for control structures and flow restrictors. Maintenance shall be a basic consideration in design and cost-determination of the stormwater management facility.

Any standing water removed during maintenance operation must be disposed of in a City-approved manner. See the dewatering requirements in Volume 4 of this manual. Pretreatment may be necessary. Solids must be disposed in accordance with state and local regulations.

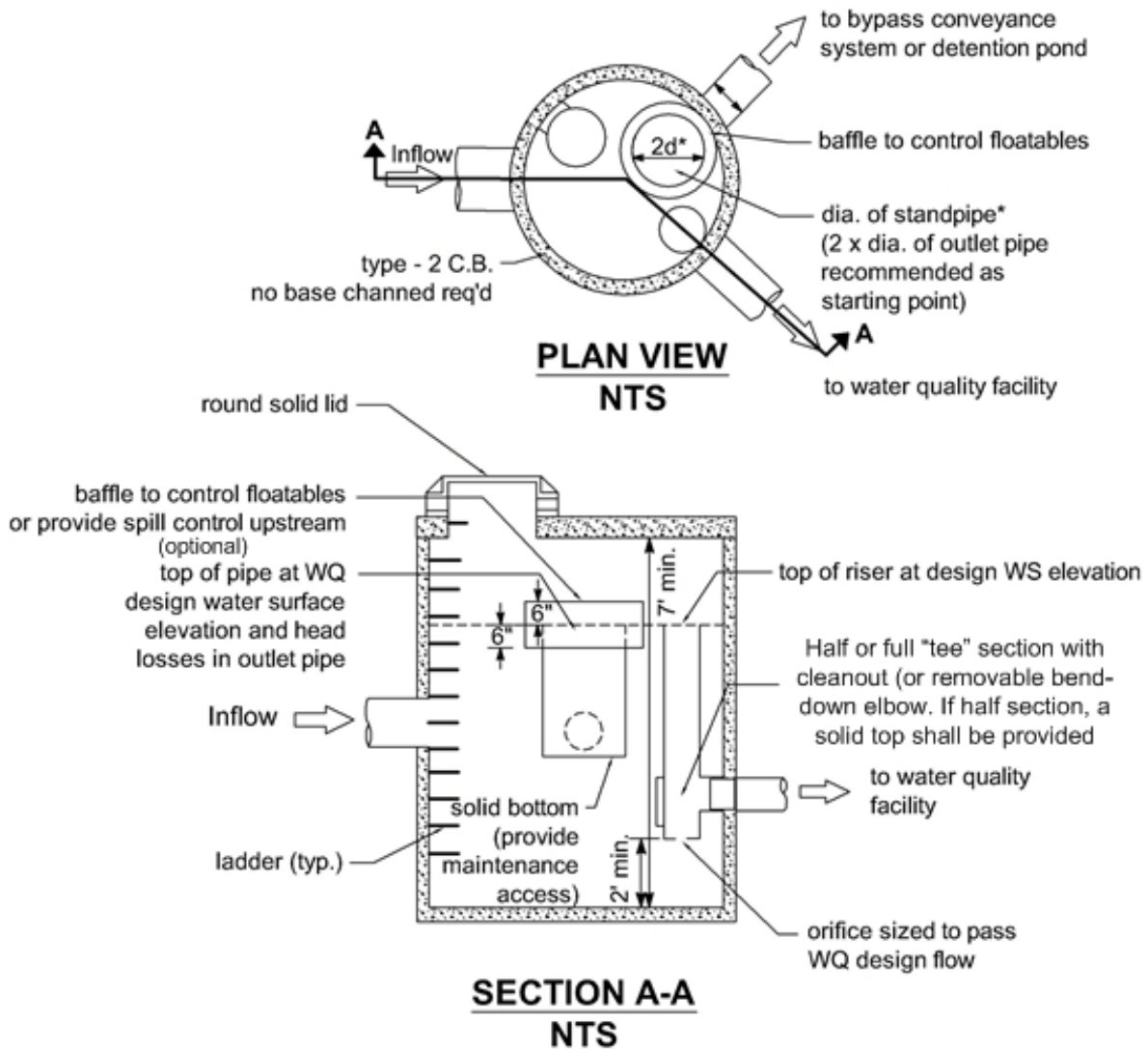
Facilities shall be designed and constructed such that the facility can be safely and easily inspected by one person and safely and easily maintained. This may require construction of additional inspection ports or access manholes to allow inspection access to be opened by one person.



**Note:** The water quality discharge pipe may require an orifice plate to be installed on the outlet to control the height of the design water surface (weir height). The design water surface should be set to provide a minimum headwater/diameter ratio of 2.0 on the outlet pipe.

**Note:** City owned flowsplitters shall have concentric cones if feasible. Access shall be provided to both sides of the baffle for maintenance.

**Figure 5 - 1. Flow Splitter, Option A**



**\*NOTE:** Diameter ( $d$ ) of standpipe should be large enough to minimize head above WQ design WS and to keep WQ design flows from increasing more than 10% during 100-year flows.

NOTE: City owned flow splitters shall have concentric cones if feasible.

*Figure 5 - 2. Flow Splitter, Option B*

## 5.2 Flow Spreading Options

Flow spreaders function to uniformly spread flows across the inflow portion of water quality facilities (e.g., sand filter, biofiltration swale, or filter strip). There are five flow spreader options presented in this section:

- Option A – Anchored plate (Figure 5 - 3)
- Option B – Concrete sump box (Figure 5 - 4)
- Option C – Notched curb spreader (Figure 5 - 5)

- Option D – Through-curb ports (Figure 5 - 6)
- Option E – Interrupted curb

Options A through C can be used for spreading flows that are concentrated. Any one of these options can be used when spreading is required by the facility design criteria. Options A through C can also be used for unconcentrated flows, and in some cases must be used, such as to correct for moderate grade changes along a filter strip.

Options D and E are only for flows that are already unconcentrated and enter a filter strip or continuous inflow biofiltration swale. Other flow spreader options may be allowed with written approval from Environmental Services.

### **5.2.1 General Design Criteria**

- Where flow enters the flow spreader through a pipe, it is recommended that the pipe be submerged to the extent practical to dissipate as much energy as possible.
- For higher inflows (greater than 5 cfs for the 100-yr storm), a Type 1 catch basin shall be positioned in the spreader and the inflow pipe shall enter the catch basin with flows exiting through the top grate. The top of the grate shall be lower than the level spreader plate, or if a notched spreader is used, lower than the bottom of the v-notches.

#### ***Option A -- Anchored Plate***

- An anchored plate flow spreader must be preceded by a sump having a minimum depth of 8 inches and minimum width of 24 inches. If not otherwise stabilized, the sump area must be lined to reduce erosion and to provide energy dissipation.
- The top surface of the flow spreader plate must be level, projecting a minimum of 2 inches above the ground surface of the water quality facility, or V-notched with notches 6 to 10 inches on center and 1 to 6 inches deep (use shallower notches with closer spacing). Alternative designs may also be used if approved by Environmental Services.
- A flow spreader plate must extend horizontally beyond the bottom width of the facility to prevent water from eroding the side slope. The horizontal extent shall be such that the bank is protected for all flows up to the 100-year flow or the maximum flow that will enter the Water Quality (WQ) facility.
- Flow spreader plates must be securely fixed in place.
- Flow spreader plates may be made of either wood, metal, fiberglass reinforced plastic, or other durable material. If wood, pressure treated 4 by 10-inch lumber or landscape timbers are acceptable.
- Anchor posts must be 4-inch square concrete, tubular stainless steel, or other material resistant to decay.

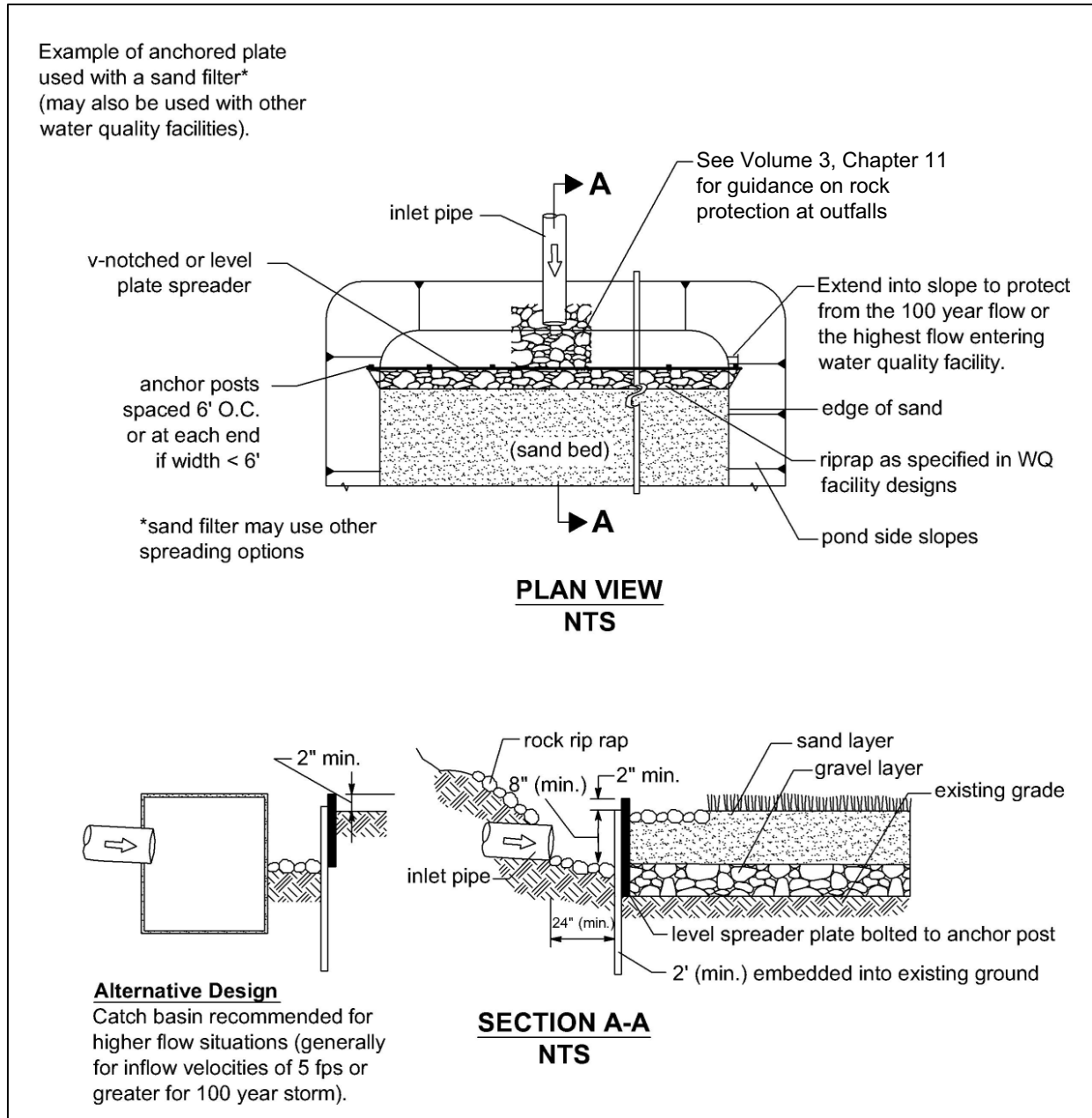
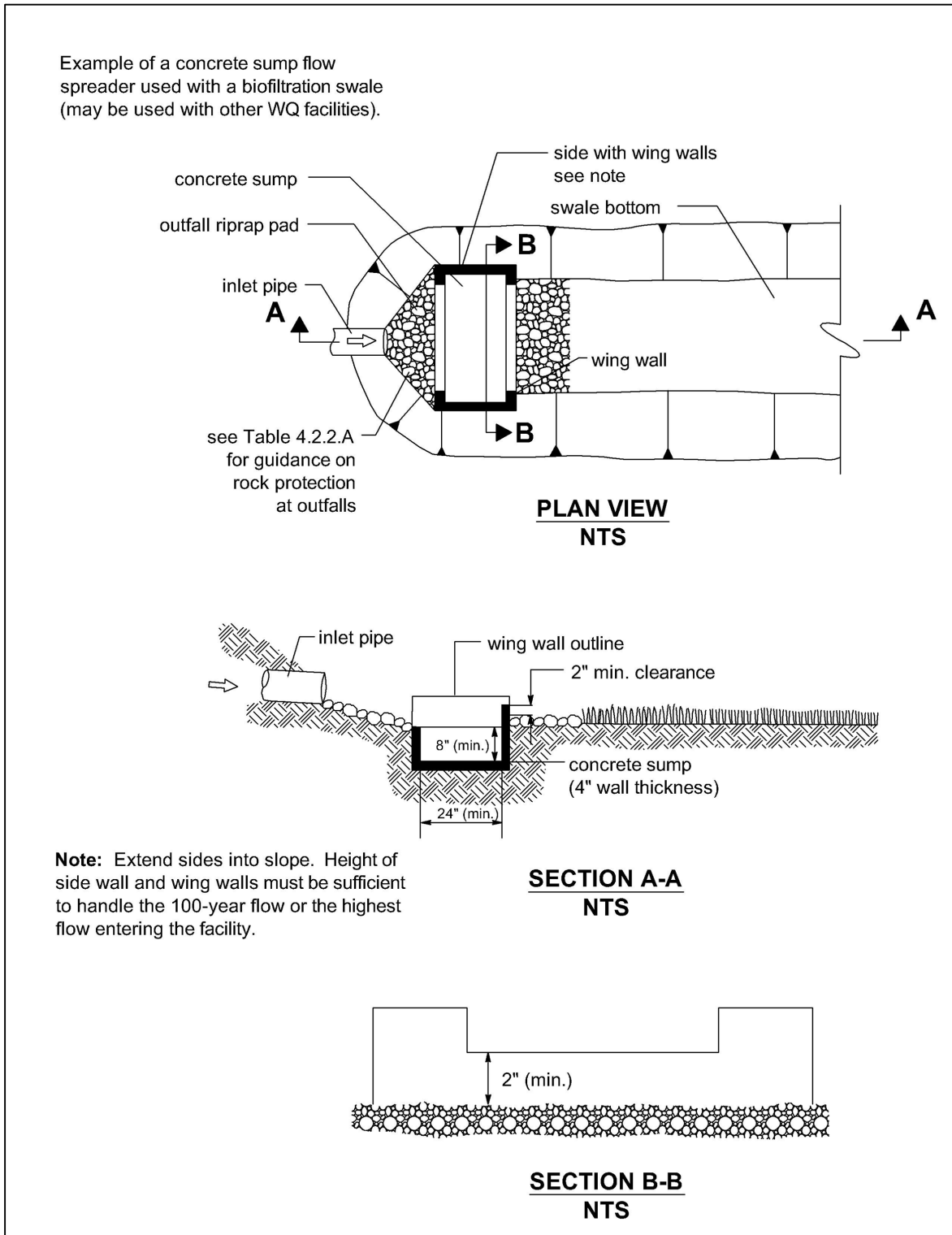


Figure 5 - 3. Flow Spreader Option A – Anchored Plate

**Option B -- Concrete Sump Box**

- The wall of the downstream side of a rectangular concrete sump box must extend a minimum of 2 inches above the treatment bed. This serves as a weir to spread the flows uniformly across the bed.
- The downstream wall of a sump box must have “wing walls” at both ends. Side walls and returns must be slightly higher than the weir so that erosion of the side slope is minimized.
- Concrete for a sump box can be either cast-in-place or precast, but the bottom of the sump must be reinforced with wire mesh for cast-in-place sumps.

- Sump boxes must be placed over bases that consists of 4 inches of crushed rock, 5/8-inch minus to help assure the sump remains level.

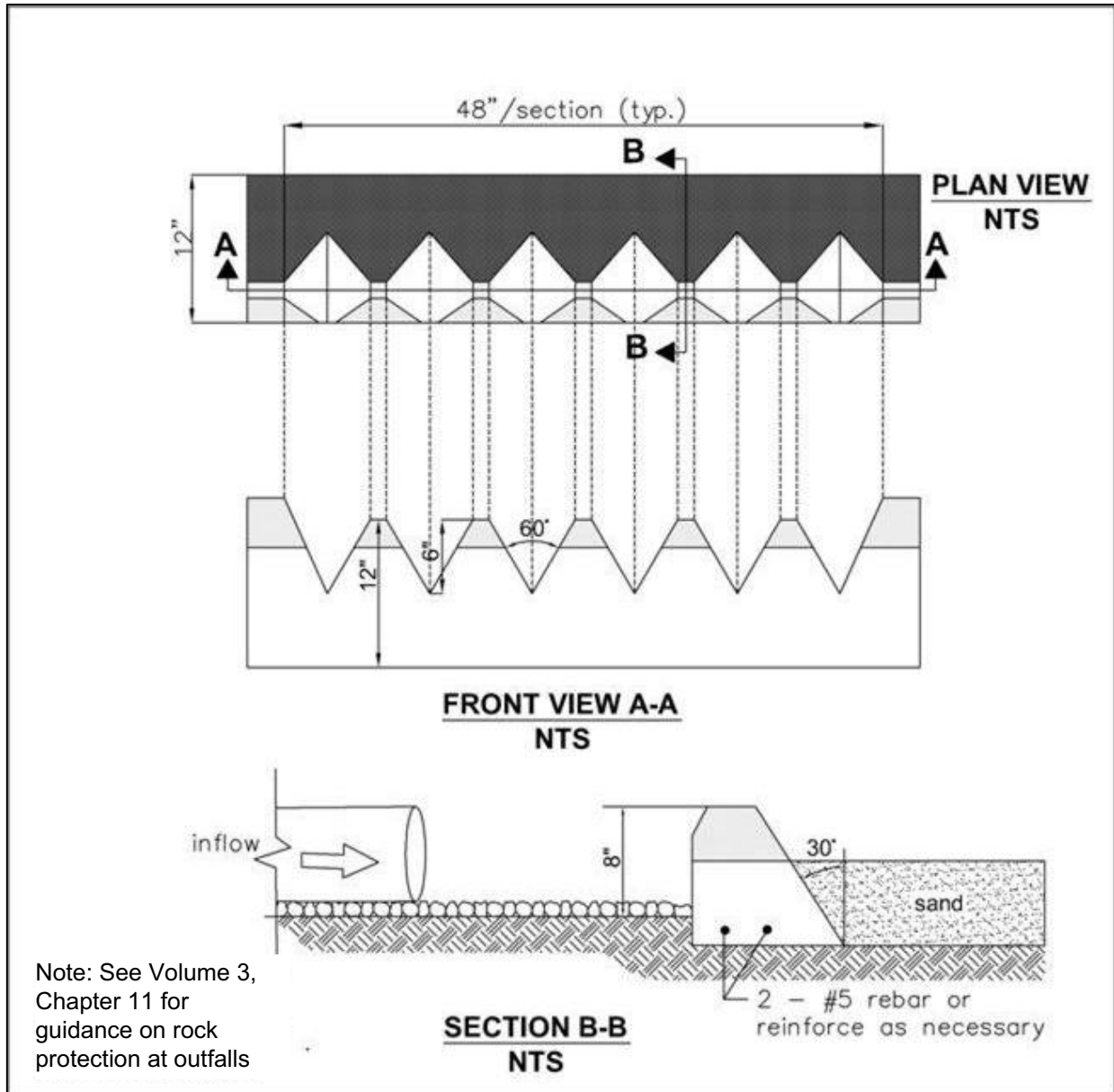


**Figure 5 - 4. Flow Spreader Option B – Concrete Sump Box**



**Option C -- Notched Curb Spreader**

Notched curb spreader sections must be made of extruded concrete laid side-by-side and level. Typically five “teeth” per four-foot section provide good spacing. The space between adjacent “teeth” forms a v-notch.



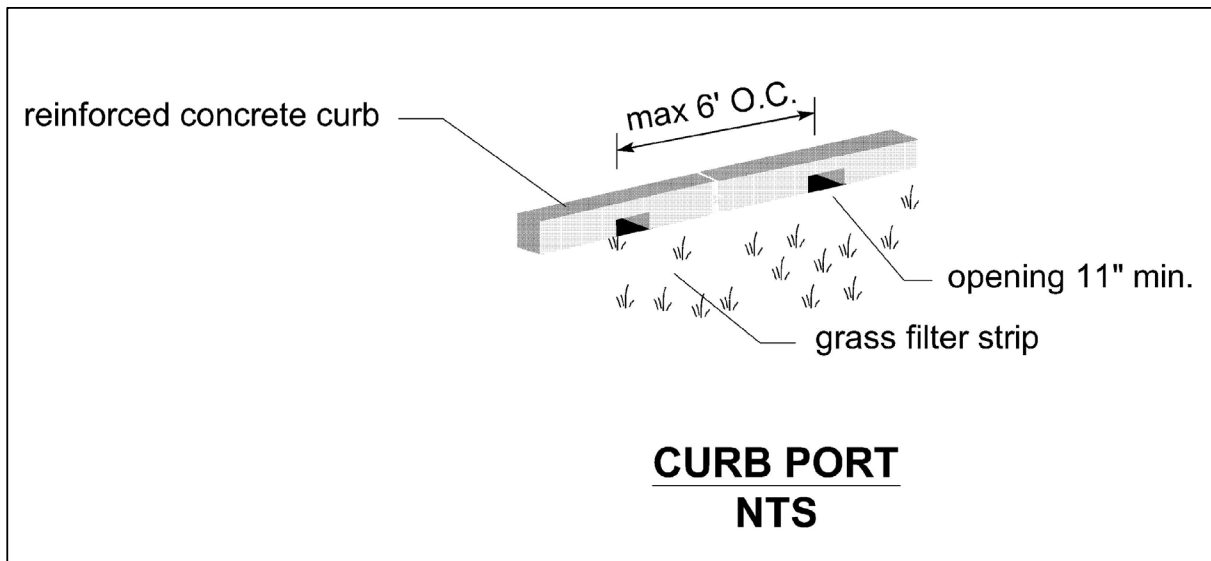
**Figure 5 - 5. Flow Spreader Option C – Notched Curb Spreader**

**Option D -- Through-Curb Ports (Figure 5 - 6)**

Unconcentrated flows from paved areas entering filter strips or continuous inflow biofiltration swales can use curb ports or interrupted curbs (Option E) to allow flows to enter the strip or

swale. Curb ports use fabricated openings that allow concrete curbing to be poured or extruded while still providing an opening through the curb to admit water to the water quality facility.

Openings in the curb must be at regular intervals but at least every 6 feet (minimum). The width of each curb port opening must be a minimum of 11 inches. Approximately 15 percent or more of the curb section length shall be in open ports, and no port shall discharge more than about 10 percent of the flow.



**Figure 5 - 6. Flow Spreader Option D – Through-Curb Ports**

### **Option E -- Interrupted Curb**

Interrupted curbs are sections of curb placed to have gaps spaced at regular intervals along the total width (or length, depending on facility) of the treatment area. At a minimum, gaps must be every 6 feet to allow distribution of flows into the treatment facility before they become too concentrated. The opening must be a minimum of 11 inches. As a general rule, no opening shall discharge more than 10 percent of the overall flow entering the facility.

### **5.2.2 Maintenance**

Per Minimum Requirement #9, an operation and maintenance plan shall be prepared for all stormwater management facilities. See Volume 1, Appendix C, Maintenance Checklist #8 for specific maintenance requirements for energy dissipators. Maintenance shall be a basic consideration in design and cost-determination of the stormwater management facility.

Any standing water removed during maintenance operation must be disposed of in a City approved manner. See the dewatering requirements in Volume 4 of this manual. Pretreatment may be necessary. Solids must be disposed of in accordance with state and local waste regulations.

Facilities shall be designed and constructed such that the facility can be safely and easily inspected by one person and safely and easily maintained. This may require construction of additional inspection ports or access manholes to allow inspection access to be opened by one person.

**This Page Intentionally Left Blank**

## Chapter 6 Pretreatment

### 6.1 Purpose

This chapter presents the methods that may be used to provide pretreatment prior to water quality facilities. Pretreatment must be provided in the following applications:

- For sand filtration and water quality infiltration BMPs to protect them from excessive siltation and debris;
- Where the proposed treatment facility may be adversely affected by a pollutant load. Environmental Services will make the final determination if pretreatment is required.

### 6.2 Application

Presettling basins are a typical pretreatment BMP used to remove suspended solids. All basic, enhanced, and phosphorus treatment options may be used for pretreatment to reduce suspended solids.

A detention pond sized to meet the flow control standard in Volume 1 may also be used to provide pretreatment for suspended solids removal.

### 6.3 Best Management Practices (BMPs) for Pretreatment

#### 6.3.1 BMP T610 Presettling Basin

##### 6.3.1.1 Purpose and Definition

A presettling basin provides pretreatment of runoff in order to remove suspended solids, which can impact other runoff treatment BMPs.

##### 6.3.1.2 Application and Limitations

Runoff treated by a presettling basin may not be discharged directly to a receiving water; it must be further treated by a basic, enhanced, or phosphorus runoff treatment BMP.

##### 6.3.1.3 Design Criteria

- A presettling basin shall be designed using analysis techniques for a wetpool or using WWHM. The treatment volume shall be at least 30 percent of the total volume of runoff from the 6-month, 24-hour storm event.
- If the runoff in the presettling basin will be in direct contact with the soil, it must be lined per the liner requirement in Chapter 4.
- The presettling basin shall conform to the following:
  - The length-to-width ratio shall be at least 3:1. Berms or baffles may be used to lengthen the flowpath.
  - The minimum depth shall be 4 feet; the maximum depth shall be 6 feet.
- Inlets and outlets shall be designed to minimize velocity and reduce turbulence. Inlet and outlet structures should be located at extreme ends of the basin in order to maximize particle-settling opportunities.

**This Page Intentionally Left Blank**

## Chapter 7 Infiltration Treatment Facilities

### 7.1 Purpose

This Chapter provides site suitability, design, and maintenance criteria for infiltration treatment systems. Infiltration treatment Best Management Practices (BMPs) serve the dual purpose of removing pollutants from stormwater and recharging aquifers.

The infiltration BMPs described in this chapter include:

- BMP T710 Infiltration basins
- BMP T720 Infiltration trenches

Bioretention facilities can be designed as infiltration facilities. See Volume 6 for bioretention design criteria.

### 7.2 Application

These infiltration treatment measures are capable of achieving the performance objectives cited in Chapter 3 for specific treatment menus. In general, these treatment techniques can capture and remove or reduce the target pollutants to levels that will not adversely affect public health or beneficial uses of surface and groundwater resources.

### 7.3 Design Methodology

#### 7.3.1 Select a location

This will be based on the ability to convey flow to the location and the expected soil conditions of the location. Do a preliminary check of Site Suitability Criteria (Section 7.6) to estimate feasibility.

#### 7.3.2 Estimate volume of stormwater, $V_{\text{design}}$

Use WWHM to estimate the design volume.

#### 7.3.3 Develop trial infiltration facility geometry

To accomplish this, an infiltration rate will need to be assumed based on previously available data, or a default infiltration rate of 0.5 inches/hour can be used. This trial facility geometry should be used to help locate the facility and for planning purposes in developing the geotechnical subsurface investigation plan.

#### 7.3.4 Complete a more detailed site characterization study and consider site suitability criteria

Information gathered during initial geotechnical and surface investigations are necessary to know whether infiltration is feasible. The geotechnical investigation evaluates the suitability of the site for infiltration, establishes the infiltration rate for design, and evaluates slope stability, foundation capacity, and other geotechnical design information needed to design and assess constructability of the facility.

The site characterization study conditions shall be assessed by a qualified engineer with geotechnical experience, or a licensed geologist, hydrogeologist, or engineering geologist.

See Sections 7.4 and 7.6.

### 7.3.5 Determine the infiltration rate

Methods for estimating the long-term infiltration rate are provided in Section 7.5.

### 7.3.6 Size the facility

The size of the infiltration facility can be determined by routing the influent runoff file generated by WWHM through it. The primary mode of discharge from an infiltration facility is infiltration into the ground. However, when the infiltration capacity of the facility is reached, additional runoff to the facility will cause the facility to overflow. Overflows from an infiltration facility designed for flow control must comply with the Minimum Requirement #7.

**NOTE:** Infiltration facilities designed for flow control do not have a required drawdown time.

In order to determine compliance with the flow control requirements, the Western Washington Hydrology Model (WWHM) must be used.

#### (A) For 100% infiltration

Using the output files from WWHM, ensure that the facility infiltrates 100% of the runoff file.

#### (B) For 91% infiltration (water quality treatment volume)

Using the output file from WWHM, ensure that the facility infiltrates 91% of the runoff file.

Infiltration facilities for treatment can be located upstream or downstream of detention and can be off-line or on-line.

- **On-line** treatment facilities placed **upstream or downstream** of a detention facility must be sized to infiltrate 91% of the runoff volume directed to it.
- **Off-line** treatment facilities placed **upstream** of a detention facility must have a flow splitter designed to send all flows at or below the 15-minute water quality flow rate, as predicted by WWHM to the treatment facility. The treatment facility must be sized to infiltrate all the runoff sent to it (no overflows from the treatment facility are allowed).
- **Off-line** treatment facilities placed **downstream** of a detention facility must have a flow splitter designed to send all flows at or below the 2-year flow frequency from the detention pond, as predicted by WWHM to the treatment facility. The treatment facility must be sized to infiltrate all the runoff sent to it (no overflows from the treatment facility are allowed).

See Volume 5, Section 5.1 for flow splitter design details.

#### (C) To meet the flow duration standard

Using the output files from WWHM, ensure that the total of any bypass and overflow from the facility meets the applicable flow control standard.

#### (D) To meet the LID performance standard

Using the output files from WWHM, ensure the total of any bypass and overflow from the facility meets the applicable LID performance standard.

#### 7.3.6.1 Drawdown Time

See Section 7.6.4.2.

### **7.3.7 Construction Criteria**

Initial basin excavation should be conducted to within 1-foot of the final elevation of the basin floor. Excavate infiltration trenches and basins to final grade only after all disturbed areas in the upgradient project drainage area have been permanently stabilized. The final phase of excavation should remove all accumulation of silt in the infiltration facility before putting it in service. Post construction all water must be conveyed through a pretreatment device to prevent sedimentation.

Infiltration facilities should generally not be used as temporary sediment traps during construction. If an infiltration facility is to be used as a sediment trap, it must not be excavated to final grade until after the upgradient drainage area has been stabilized. Any accumulation of silt in the basin must be removed before putting it in service.

Traffic Control – Relatively light-tracked equipment is recommended for use within infiltration areas for excavation and cleaning to avoid compaction of the basin floor. The use of draglines and trackhoes should be considered for constructing infiltration basins. The infiltration area should be flagged or marked to keep heavy equipment away.

### **7.3.8 Maintenance Criteria**

Per Minimum Requirement #9, an operation and maintenance plan shall be prepared for all stormwater management facilities. See Volume 1, Appendix C for specific maintenance requirements. Maintenance shall be a basic consideration in design and cost-determination of the stormwater management facility.

Any standing water removed during the maintenance operation must be disposed of in a City approved manner. See the dewatering requirements in Volume 4 of this manual. Pretreatment may be necessary. Solids must be disposed of in accordance with state and local waste regulations.

Facilities shall be designed and constructed such that the facility can be safely and easily inspected by one person and safely and easily maintained. This may require construction of additional inspection ports or access manholes to allow inspection access to be opened by one person.

### **7.3.9 Verification Testing of the Completed Facility**

Verification testing of the completed facility is recommended to demonstrate that the facility performs as designed. Use the same method for saturated hydraulic conductivity as used in the planning stages to ensure comparable results. Perform the testing after stabilizing the construction site. If the rates are lower than the design saturated hydraulic conductivity, the applicant shall implement measures to improve infiltration capability of the facility and retest. Replacement of the top foot of soil or more may be needed to ensure the facility performs as designed. Longer-term monitoring of the facility may be needed for some facilities. Environmental Services may require verification testing on a case-by-case basis.

## **7.4 Site Characterization Criteria**

One of the first steps in siting and designing infiltration facilities is to conduct a characterization study. Information gathered during initial geotechnical investigations can be used for the site characterization.



### **7.4.1 Surface Features Characterization**

- Topography within 500 feet of the proposed facility.
- Anticipated site use (street/highway, residential, commercial, high-use site).
- Location of water supply wells within 500 feet of proposed facility.
- Location of groundwater protection areas and/or 1, 5 and 10 year time of travel zones for municipal well protection areas.
- A description of local site geology, including soil or rock units likely to be encountered, the groundwater regime, and geologic history of the site.

### **7.4.2 Subsurface Characterization**

- Conduct pit/hole explorations during the wet season (December 1<sup>st</sup> through March 31<sup>st</sup>) to provide accurate groundwater saturation and groundwater information.
- Subsurface explorations (test holes or test pits) to a depth below the base of the infiltration facility of at least 5 times the maximum design depth of ponded water proposed for the infiltration facility, but not less than 10 feet.
- Continuous sampling (representative samples from each soil type and/or unit within the infiltration receptor) to a depth below the base of the infiltration facility of 2.5 times the maximum design ponded water depth, but not less than 10 feet.
- For basins, at least one test pit or test hole per 5,000 ft<sup>2</sup> of basin infiltrating surface (in no case less than two per basin).
- For trenches, at least one test pit or test hole per 200 feet of trench length (in no case less than two per trench).
- For large infiltration facilities serving drainage areas of 10 acres or more, perform soil grain size analyses on layers up to 50 feet deep or no more than 10 feet below the groundwater table.

The depth and number of test holes or test pits and samples should be increased, if in the judgment of a licensed engineer with geotechnical expertise (P.E.), a licensed geologist, engineering geologist, hydrogeologist, or other licensed professional acceptable to the City, the conditions are highly variable and such increases are necessary to accurately estimate the performance of the infiltration system. The exploration program may be decreased if, in the opinion of the licensed engineer or other professional, the conditions are relatively uniform and the borings/test pits omitted will not influence the design or successful operation of the facility. In high water table sites, the subsurface exploration sampling need not be conducted lower than two (2) feet below the groundwater table.

Prepare detailed logs for each test pit or test hole and a map showing the location of the test pits or test holes. Logs must include at a minimum, depth of pit or hole, soil descriptions, depth to water, and presence of stratification. Logs must substantiate whether stratification does or does not exist. The licensed professional may consider additional methods of analysis to substantiate the presence of stratification that will significantly impact the design of the infiltration facility.

### **7.4.3 Infiltration Rate Determination**

Determine the representative infiltration rate of the unsaturated vadose zone based on methods outlined in Section 7.5.

#### 7.4.4 Soil Testing

Soil characterization for each soil unit (soils of the same texture, color, density, compaction, consolidation and permeability) encountered must be based upon the method used for determining the long-term infiltration rate (see Section 7.5) and must also include:

- Percent clay content (include type of clay, if known)
- Color/mottling
- Variations and nature of stratification

#### 7.4.5 Infiltration Receptor

The requirements of this section will be applied as directed by Environmental Services. Infiltration receptor (unsaturated and saturated soil receiving the stormwater) characterization should include:

- Installation of groundwater monitoring wells (at least three per infiltration facility, or three hydraulically connected surface and groundwater features that will establish a three-dimensional relationship for the groundwater table, unless the highest groundwater level is known to be at least 50 feet below the proposed infiltration facility) to:
  - Monitor the seasonal groundwater levels at the site during at least one wet season, and,
  - Consider the potential for both unconfined and confined aquifers, or confining units, at the site that may influence the proposed infiltration facility as well as the groundwater gradient. Other approaches to determine groundwater levels at the proposed site could be considered if pre-approved by Environmental Services, and
  - Determine the ambient groundwater quality, if that is a concern.
- An estimate of the volumetric water holding capacity of the infiltration receptor soil. This is the soil layer below the infiltration facility and above the seasonal high-water mark, bedrock, hardpan, or other low permeability layer. This analysis should be conducted at a conservatively high infiltration rate based on vadose zone porosity, and the water quality runoff volume to be infiltrated. This, along with an analysis of groundwater movement, will be useful in determining if there are volumetric limitations that would adversely affect drawdown.
- Determination of:
  - Depth to groundwater table and to bedrock/impermeable layers
  - Seasonal variation of groundwater table based on well water levels and observed mottling
  - Existing groundwater flow direction and gradient
  - Lateral extent of infiltration receptor
  - Horizontal hydraulic conductivity of the saturated zone to assess the aquifer's ability to laterally transport the infiltrated water.
- Impact of the infiltration rate and volume at the project site on groundwater mounding, flow direction, and water table; and the discharge point or area of the infiltrating water. A groundwater mounding analysis should be conducted at all sites where the depth to seasonal groundwater table or low permeability stratum is less than 15 feet and the runoff to the infiltration facility is from more than one acre. (The site professional may consider

conducting an aquifer test, or slug test to aid in determining the type of groundwater mounding analysis necessary at the site)

A detailed soils and hydrogeologic investigation should be conducted if potential pollutant impacts to groundwater are a concern, or if the applicant is proposing to infiltrate in areas underlain by till or other impermeable layers. (Suggested references: “Implementation Guidance for the Groundwater Quality Standards”, Department of Ecology, publication 96-2, 2005).

## **7.5 Design Saturated Hydraulic Conductivity – Guidelines and Criteria**

Measured (initial) hydraulic saturated conductivity rates can be determined by one of the following three methods. The Soil Grain Size Analysis Method can only be used if the site soils are unconsolidated by glacial advance.

- Large Scale Pilot Infiltration Test (PIT) – Section 7.5.1
- Small Scale Pilot Infiltration Test (PIT) – Section 7.5.2
- Soil Grain Size Analysis Method – Section 7.5.3

### **7.5.1 Large Scale Pilot Infiltration Test (PIT)**

Large-scale in-situ infiltration measurements, using the Pilot Infiltration Test (PIT) described below is the preferred method for estimating the measured (initial) saturated hydraulic conductivity (Ksat) of the soil profile beneath the proposed infiltration facility. The PIT reduces some of the scale errors associated with relatively small-scale double ring infiltrometer or “stove-pipe” infiltration tests. It is not a standard test but rather a practical field procedure recommended by Ecology’s Technical Advisory Committee.

#### **7.5.1.1 Infiltration Test**

- Excavate the test pit to the estimated surface elevation of the proposed infiltration facility. Lay back the slopes sufficiently to avoid caving and erosion during the test. Alternatively, consider shoring the sides of the test pit.
- The horizontal surface area of the bottom of the test pit should be approximately 100 square feet. Accurately document the size and geometry of the test pit.
- Install a vertical measuring rod (minimum 5-ft. long) marked in half-inch increments in the center of the pit bottom.
- Use a rigid 6-inch diameter pipe with a splash plate on the bottom to convey water to the pit and reduce side-wall erosion or excessive disturbance of the pond bottom. Excessive erosion and bottom disturbance will result in clogging of the infiltration receptor and yield lower than actual infiltration rates.
- Add water to the pit at a rate that will maintain a water level between 6 and 12 inches above the bottom of the pit. A rotameter can be used to measure the flow rate into the pit.

**NOTE:** Note: The depth should not exceed the proposed maximum depth of water expected in the completed facility. For infiltration facilities serving large drainage areas, designs with multiple feet of standing water can have infiltration tests with greater than 1 foot of standing water.

Every 15-30 min, record the cumulative volume and instantaneous flow rate in gallons per minute necessary to maintain the water level at the same point on the measuring rod.

Keep adding water to the pit until one hour after the flow rate into the pit has stabilized (constant flow rate; a goal of 5% variation or less variation in the total flow) while maintaining the same pond water level. The total of the pre-soak time plus one hour after the flow rate has stabilized should be no less than 6 hours.

- After the flow rate has stabilized for at least one hour, turn off the water and record the rate of infiltration (the drop rate of the standing water) in inches per hour from the measuring rod data, until the pit is empty. Consider running this falling head phase of the test several times to estimate the dependency of infiltration rate with head.
- At the conclusion of testing, over-excavate the pit to see if the test water is mounded on shallow restrictive layers or if it has continued to flow deep into the subsurface. The depth of excavation varies depending on soil type and depth to hydraulic restricting layer, and is determined by the engineer or certified soils professional. Mounding is an indication that a mounding analysis is necessary.

### 7.5.1.2 Data Analysis

Calculate and record the saturated hydraulic conductivity rate in inches per hour in 30 minutes or one-hour increments until one hour after the flow has stabilized.

**NOTE:** Note: Use statistical/trend analysis to obtain the hourly flow rate when the flow stabilizes. This would be the lowest hourly flow rate.

Apply appropriate correction factors per Volume 3, Section 6.5.4 to determine the site-specific design infiltration rate.

#### Example

The area of the bottom of the test pit is 8.5-ft. by 11.5-ft.

Water flow rate was measured and recorded at intervals ranging from 15 to 30 minutes throughout the test. Between 400 minutes and 1,000 minutes the flow rate stabilized between 10 and 12.5 gallons per minute or 600 to 750 gallons per hour, or an average of  $(9.8 + 12.3) / 2 = 11.1$  inches per hour.

## 7.5.2 Small Scale Pilot Infiltration Test (PIT)

A smaller-scale PIT can be substituted for the large-scale PIT in any of the following instances.

- The drainage area to the infiltration site is less than 1 acre.
- The testing is for the LID BMP's of bioretention or permeable pavement that either serve small drainage areas and /or are widely dispersed throughout a project site.
- The site has a high infiltration rate, making a full-scale PIT difficult, and the site geotechnical investigation suggests uniform subsurface characteristics.

### 7.5.2.1 Infiltration Test

- Excavate the test pit to the estimated surface elevation of the proposed infiltration facility. In the case of bioretention, excavate to the estimated top elevation where the imported soil mix meets the underlying native soil. For permeable pavements, excavate to the elevation at which the imported subgrade materials, or the pavement itself, will contact the underlying native soil. If the native soils (road subgrade) will have to meet a minimum subgrade compaction requirement, compact the native soil to that requirement prior to testing. Note that the permeable pavement design guidance recommends compaction not

exceed 90% - 92%. Finally, lay back the slopes sufficiently to avoid caving and erosion during the test. Alternatively, consider shoring the sides of the test pit.

- The horizontal surface area of the bottom of the test pit should be 12 to 32 square feet. It may be circular or rectangular, but accurately document the size and geometry of the test pit.
- Install a vertical measuring rod adequate to measure the ponded water depth and that is marked in half-inch increments in the center of the pit bottom.
- Use a rigid pipe with a splash plate on the bottom to convey water to the pit and reduce side-wall erosion or excessive disturbance of the pond bottom. Excessive erosion and bottom disturbance will result in clogging of the infiltration receptor and yield lower than actual infiltration rates. Use a 3 inch diameter pipe for pits on the smaller end of the recommended surface area, and a 4 inch pipe for pits on the larger end of the recommended surface area.
- Pre-soak period: Add water to the pit so that there is standing water for at least 6 hours. Maintain the pre-soak water level at least 12 inches above the bottom of the pit.
- At the end of the pre-soak period, add water to the pit at a rate that will maintain a 6-12 inch water level above the bottom of the pit over a full hour. The depth should not exceed the proposed maximum depth of water expected in the completed facility.
- Every 15 minutes, record the cumulative volume and instantaneous flow rate in gallons per minute necessary to maintain the water level at the same point (between 6 inches and 1 foot) on the measuring rod. The specific depth should be the same as the maximum designed ponding depth (usually 6 – 12 inches).
- After one hour, turn off the water and record the rate of infiltration (the drop rate of the standing water) in inches per hour from the measuring rod data, until the pit is empty.
- A self-logging pressure sensor may also be used to determine water depth and drain-down.
- At the conclusion of testing, over-excavate the pit to see if the test water is mounded on shallow restrictive layers or if it has continued to flow deep into the subsurface. The depth of excavation varies depending on soil type and depth to hydraulic restricting layer, and is determined by the engineer or certified soils professional. The soils professional should judge whether a mounding analysis is necessary.

### 7.5.2.2 Data Analysis

Calculate and record the saturated hydraulic conductivity rate in inches per hour in 30 minutes or one-hour increments until one hour after the flow has stabilized.

**NOTE:** Note: Use statistical/trend analysis to obtain the hourly flow rate when the flow stabilizes. This would be the lowest hourly flow rate.

Apply appropriate correction factors per Volume 3, Section 6.5.4 to determine the site-specific design infiltration rate.

#### Example

The area of the bottom of the test pit is 8.5-ft. by 11.5-ft.

Water flow rate was measured and recorded at intervals ranging from 15 to 30 minutes throughout the test. Between 400 minutes and 1,000 minutes the flow rate stabilized between 10 and 12.5 gallons per minute or 600 to 750 gallons per hour, or an average of  $(9.8 + 12.3) / 2 = 11.1$  inches per hour.

### 7.5.3 Soil Grain Size Analysis Method

For each defined layer below the infiltration facility to a depth below the facility bottom of 2.5 times the maximum depth of water in the facility, but not less than 10 feet, estimate the saturated hydraulic conductivity in cm/sec using the following relationship (see Massmann 2003, and Massmann et al., 2003). For large infiltration facilities serving drainage areas of 10 acres or more, soil grain size analysis shall be performed on layers up to 50 feet deep (or no more than 10 feet below the water table).

$$\log_{10}(K_{sat}) = -1.57 + 1.90D_{10} + 0.015D_{60} - 0.013D_{90} - 2.08F_{fines} \quad (\text{equation 1})$$

Where,  $D_{10}$ ,  $D_{60}$  and  $D_{90}$  are the grain sizes in mm for which 10 percent, 60 percent and 90 percent of the sample is more fine and  $f_{fines}$  is the fraction of the soil (by weight) that passes the #200 sieve ( $K_{sat}$  is in cm/s).

For bioretention facilities, analyze each defined layer below the top of the final bioretention area subgrade to a depth of at least 3 times the maximum ponding depth, but not less than 3 feet (1 meter). For permeable pavement, analyze for each defined layer below the top of the final subgrade to a depth of at least 3 times the maximum ponding depth within the base course, but not less than 3 feet (1 meter).

If the licensed professional conducting the investigation determines that deeper layers will influence the rate of infiltration for the facility, soil layers at greater depths must be considered when assessing the site's hydraulic conductivity characteristics. Massmann (2003) indicates that where the water table is deep, soil or rock strata up to 100 feet below an infiltration facility can influence the rate of infiltration. Note that only the layers near and above the water table or low permeability zone (e.g., a clay, dense glacial till, or rock layer) need to be considered, as the layers below the groundwater table or low permeability zone do not significantly influence the rate of infiltration. Also note that this equation for estimating hydraulic conductivity assumes minimal compaction consistent with the use of tracked (i.e., low to moderate ground pressure) excavation equipment. If the soil layer being characterized has been exposed to heavy compaction, the hydraulic conductivity for the layer could be approximately an order of magnitude less than what would be estimated based on grain size characteristics alone (Pitt, 2003). In such cases, compaction effects must be taken into account when estimating hydraulic conductivity. For clean, uniformly graded sands and gravels, the reduction in  $K_{sat}$  due to compaction will be much less than an order of magnitude. For well-graded sands and gravels with moderate to high silt content, the reduction in  $K_{sat}$  will be close to an order of magnitude. For soils that contain clay, the reduction in  $K_{sat}$  could be greater than an order of magnitude.

If greater certainty is desired, the in-situ saturated conductivity of a specific layer can be obtained through the use of a pilot infiltration test (PIT). Note that these field tests generally provide a hydraulic conductivity combined with a hydraulic gradient. In some of these tests, the hydraulic gradient may be close to 1.0; therefore, in effect, the magnitude of the test result is the same as the hydraulic conductivity. In other cases, the hydraulic gradient may be close to the gradient that is likely to occur in the full-scale infiltration facility. The hydraulic gradient will need to be evaluated on a case-by-case basis when interpreting the results of field tests. It is important to recognize that the gradient in the test may not be the same as the gradient likely to occur in the full-scale infiltration facility in the long-term (i.e., when groundwater mounding is fully developed).

Once the saturated hydraulic conductivity for each layer has been identified, determine the effective average saturated hydraulic conductivity below the facility. Hydraulic conductivity estimates from different layers can be combined using the harmonic mean.

$$K_{equiv} = \frac{d}{\sum \frac{d_i}{K_i}} \quad \text{(equation 2)}$$

Where, *d* is the total depth of the soil column, *d<sub>i</sub>* is the thickness of layer “*i*” in the soil column, and *K<sub>i</sub>* is the saturated hydraulic conductivity of layer “*i*” in the soil column. The depth of the soil column, *d*, typically would include all layers between the facility bottom and the water table. However, for sites with very deep water tables (>100 feet) where groundwater mounding to the base of the facility is not likely to occur, it is recommended that the total depth of the soil column in Equation 2 be limited to approximately 20 times the depth of facility, but not more than 50 ft. This is to ensure that the most important and relevant layers are included in the hydraulic conductivity calculations. Deep layers that are not likely to affect the infiltration rate near the facility bottom should not be included in Equation 2. Equation 2 may over-estimate the effective hydraulic conductivity value at sites with low conductivity layers immediately beneath the infiltration facility. For sites where the lowest conductivity layer is within five feet of the base of the pond, it is suggested that this lowest hydraulic conductivity value be used as the equivalent hydraulic conductivity rather than the value from Equation 2. Using the layer with the lowest *K<sub>sat</sub>* is advised for designing bioretention facilities or permeable pavements. The harmonic mean given by Equation 2 is the appropriate effective hydraulic conductivity for flow that is perpendicular to stratigraphic layers, and will produce conservative results when flow has a significant horizontal component such as could occur due to groundwater mounding.

**7.5.4 Correction Factors**

The hydraulic saturated conductivity obtained from the PIT test or Soil Grain Size Analysis Method is an initial rate. This initial rate shall be reduced through correction factors that are appropriate for the design situation to produce a design infiltration rate. Use the correction factors from Table 3-9 below or alternative values can be proposed based upon the professional judgment of the licensed engineer or site professional. Justification for alternate values must be provided to Environmental Services.

**Table 5 - 6: Measured Hydraulic Saturated Conductivity Rate Reduction Factors**

Issue	Partial Correction Factor
Site Variability and Number of Locations Tested	CF <sub>v</sub> = 0.33 to 1.0
Test Method	
<ul style="list-style-type: none"> <li>• Large-Scale PIT</li> </ul>	CF <sub>t</sub> = 0.75

• Small-Scale PIT	$CF_t = 0.50$
• Grain Size Method	$CF_t = 0.40$
Siltation and Biofouling	$CF_m = 0.9$

Total Correction Factor,  $CF_T = CF_v \times CF_t \times CF_m$

$$K_{\text{sat design}} = K_{\text{sat initial}} * CF_T$$

#### 7.5.4.1 Site variability and number of locations tested ( $CF_v$ )

The number of locations tested must be capable of producing a picture of the subsurface conditions that fully represents the conditions throughout the facility site. The partial correction factor used for this issue depends on the level of uncertainty that adverse subsurface conditions may occur. If the range of uncertainty is low - for example, conditions are known to be uniform through previous exploration and site geological factors - one pilot infiltration test (or grain size analysis location) may be adequate to justify a partial correction factor at the high end of the range.

If the level of uncertainty is high, a partial correction factor near the low end of the range may be appropriate. This might be the case where the site conditions are highly variable due to conditions such as a deposit of ancient landslide debris, or buried stream channels. In these cases, even with many explorations and several pilot infiltration tests (or several grain size test locations), the level of uncertainty may still be high.

A partial correction factor near the low end of the range could be assigned where conditions have a more typical variability, but few explorations and only one pilot infiltration test (or one grain size analysis location) is conducted. That is, the number of explorations and tests conducted do not match the degree of site variability anticipated.

#### 7.5.4.2 Uncertainty of Test Method ( $CF_t$ )

This correction factor accounts for uncertainties in the testing methods. These values are intended to represent the difference in each test's ability to estimate the actual saturated hydraulic conductivity. The assumption is the larger the scale of the test, the more reliable the result.

#### 7.5.4.3 Siltation and Biofouling ( $CF_m$ )

Even with a presettling basin or a basic treatment facility for pretreatment, the soil's initial infiltration rate will gradually decline as more and more stormwater, with some amount of suspended material, passes through the soil profile. The maintenance schedule calls for removing sediment when the facility is infiltrating at only 90% of its design capacity. Therefore, a correction factor,  $CF_m$ , of 0.9 is called for.

## 7.6 Site Suitability

The following site suitability criteria must be considered as well as the above design criteria. When a site investigation reveals that any of the eight applicable criteria cannot be met, appropriate mitigation measures must be implemented so that the infiltration facility will not pose a threat to safety, health, and the environment.

For site selection and design decisions a geotechnical and hydrogeologic report must be prepared by a qualified engineer with geotechnical and hydrogeologic experience, or an equivalent professional acceptable to the City, under the seal of a registered Professional



Engineer. The design engineer may utilize a team of certified or registered professionals in soil science, hydrogeology, geology, and other related fields. The results of this report must meet all applicable standards in the design criteria section above.

### **7.6.1 Setback Criteria**

Typical setbacks are outlined in Section 3.3.

Setback criteria for the various infiltration and dispersion facilities can be found in the design criteria for each BMP in this chapter. ***Below are conditions that the soils professional must evaluate to determine the need for additional or more stringent setbacks than outlined in this manual.***

The professional must evaluate:

- Potential impacts to drinking water wells, septic tanks or drainfields, and springs used for public drinking water supplies.
- Potential impacts from roadways subject to deicers or herbicides which are likely to be present in the influent to the infiltration system.
- Potential impacts to all building foundations in the vicinity of the proposed infiltration facility. Recommend investigating all building foundations: within 100 feet upslope and 20 feet downslope from the facility.
- Potential impacts to all property lines within 20 feet of the facility.
- Potential impacts to a Native Growth Protection Easement (NGPE);  $\geq 20$  feet.
- Potential impacts to the top of slopes  $>15\%$  and within 50 feet.
- On-site and off-site structural stability due to extended subgrade saturation and/or head loading of the permeable layer, including the potential impacts to downgradient properties, especially on hills with known side-hill seeps.

### **7.6.2 Groundwater Protection Areas**

A site is not suitable if the infiltration facility will cause a violation of Ecology's Groundwater Quality Standards.

The City of Tacoma Public Works Department and Tacoma-Pierce County Health Department developed a guidance document that provides the circumstances and requirements for approval of infiltration facilities for managing pollution-generating stormwater runoff in the STGPD. The document, "Implementation of Stormwater Infiltration for Pollution-Generating Surfaces in the South Tacoma Groundwater Protection District" is available at [www.cityoftacoma.org/stormwater](http://www.cityoftacoma.org/stormwater).

See Chapter 2 of Volume 1 for geographic-specific requirements.

### **7.6.3 High Vehicle Traffic Areas**

An infiltration BMP may be considered for runoff from areas of industrial activity and the high vehicle traffic areas described below. For such applications sufficient pollutant removal (including oil removal) shall be provided upstream of the infiltration facility to ensure that groundwater quality standards will not be violated and that the infiltration facility is not adversely affected.

High Vehicle Traffic Areas are:

- Commercial or industrial sites subject to an expected average daily traffic count (ADT)  $\geq 100$  vehicles/1,000 ft<sup>2</sup> gross building area (trip generation), and
- Road intersections with an ADT of  $\geq 25,000$  on the main roadway, or  $\geq 15,000$  on any intersecting roadway.

## **7.6.4 Soil Infiltration Rate/Drawdown Time for Treatment**

### **7.6.4.1 Infiltration Rates: Measured (initial) and Design (long-term)**

For treatment purposes, the measured (initial) soil infiltration rate shall be 9 inches/hour or less. Design (long-term) infiltration rates up to 3 inches/hour can be considered if the infiltration receptor is not a sole-source aquifer, and in the judgment of the site professional the treatments soil has characteristics comparable to Section 7.6.6.

The design (long-term) infiltration rate should be used for drawdown time and routing calculations.

### **7.6.4.2 Drawdown Time**

Refer to Section 7.5 for infiltration rate determination. Document that the water quality design storm volume (indicated by WWHM) can infiltrate through the infiltration basin surface within 48 hours. This can be calculated using a horizontal projection of the infiltration basin mid-depth dimensions and the estimated design infiltration rate, and multiply the results by 48 hours.

This drawdown restriction is intended to meet the following objectives:

- Restore hydraulic capacity to receive runoff from a new storm,
- Maintain infiltration rates,
- Aerate vegetation and soil to keep the vegetation healthy, and
- Enhance the biodegradation of pollutants and organics in the soil.

## **7.6.5 Depth to Bedrock, Water Table, or Impermeable Layer**

The base of all infiltration basins or trench systems shall be  $\geq 5$  feet above the seasonal high-water mark, bedrock (or hardpan) or other low permeability layer. A separation down to 3 feet may be considered if the groundwater mounding analysis, volumetric receptor capacity, and the design of the overflow and/or bypass structures are judged by the site professional to be adequate to prevent overtopping and meet the site suitability criteria specified in this section.

## **7.6.6 Soil Physical and Chemical Suitability for Treatment**

The soil texture and design infiltration rates shall be considered along with the physical and chemical characteristics specified below to determine if the soil is adequate for removing the target pollutants. The following soil properties must be carefully considered in making such a determination:

- Cation exchange capacity (CEC) of the treatment soil must be  $\geq 5$  milliequivalents CEC/100 g dry soil (USEPA Method 9081). *Consider empirical testing of soil sorption capacity, if practicable.* Ensure that soil CEC is sufficient for expected pollutant loadings, particularly heavy metals. CEC values of  $>5$  meq/100g are expected in loamy sands, according to Rawls, et al.
- Depth of soil used for infiltration treatment must be a minimum of 18 inches.

- Organic content shall be a minimum of 1%. Organic content shall be measured on a dry weight basis using ASTM D2974.
- Waste fill materials should not be used as infiltration soil media nor should such media be placed over uncontrolled or non-engineered fill soils.

Engineered soils may be used to meet the design criteria in this chapter and the performance goals in Chapter 2 and Chapter 3. The treatment soils must not leach pollutants into the groundwater table or underground piping. Pollutants can include but not be limited to high or low pH, phosphorus and heavy metals. Environmental Services may require that additional testing be conducted on the treatment soils.

### **7.6.7 Seepage Analysis and Control**

Determine whether there would be any adverse effects caused by seepage zones on nearby building foundations, basements, roads, parking lots or sloping sites.

### **7.6.8 Cold Climate and Impact of Roadway Deicers**

For cold climate design criteria (snowmelt/ice impacts) refer to D. Caraco and R. Claytor, "Stormwater BMP Design Supplement for Cold Climates", Center for Watershed Protection, 1997.

Potential impact of roadway deicers on potable water wells must be considered in the siting determination. Mitigation measures must be implemented if infiltration of roadway deicers can cause a violation of groundwater quality standards.

## **7.7 Best Management Practices (BMPs) for Infiltration Treatment**

The three BMPs discussed below are recognized currently as effective treatment techniques using infiltration and bio-infiltration. Selection of a specific BMP should be based on the Treatment Facility Menus provided in Chapter 2.

### **7.7.1 Design Criteria for Infiltration Facilities**

#### **7.7.1.1 Infiltration Facility Access**

- The infiltration facility shall be easily accessible in order to perform necessary inspections and maintain the facility.
- Maintenance access road(s) shall be provided to the control structure and other drainage structures associated with the facility.
- Post construction, all water must be conveyed through a pretreatment device to prevent sedimentation.
- Access roads/ramps must meet the following requirements:
  - Access roads may be constructed with an asphalt or gravel surface, or modular grid pavement.
  - Maximum grade shall be 15 percent.
  - Outside turning radius shall be a minimum of 40 feet.
  - Fence gates shall be located only on straight sections of road.
  - Access roads shall be 15 feet in width on curves and 12 feet on straight sections.
  - A driveway meeting City design standards must be provided where access roads connect to paved public roadways.
- If a fence is required, access shall be limited by a double-posted gate. If a fence is not required, access shall be limited by two fixed bollards on each side of the access road and two removable bollards equally located between the fixed bollards.
- Additional easements or modifications to proposed lot boundaries may be required to provide adequate access to stormwater facilities. Right-of-way may be needed for facility maintenance. Any tract not abutting public right-of-way shall have a 15-foot wide extension of the tract to an acceptable access location.

#### **7.7.1.2 Infiltration Facility Overflow**

Provide for a primary overflow designed to bypass the 100-year, 24-hour developed peak flowrate or 100-year return period flowrate as estimated by WWHM. The design must provide controlled discharge to a location acceptable to Environmental Services.

#### **7.7.1.3 Infiltration Facility Seeps and Springs**

Intermittent seeps along cut slopes are typically fed by a shallow groundwater source (interflow) flowing along a relatively impermeable soil stratum. These flows are storm driven. However, more continuous seeps and springs, which extend through longer dry periods, are likely from a deeper groundwater source. When continuous flows are intercepted and directed through infiltration facilities, adjustments to the facility design shall be made to account for the additional base flow. Flow monitoring of intercepted flow may be required for design purposes.

#### **7.7.1.4 Infiltration Facility Construction Criteria**

Construct the facility in a way that does not compact the infiltration facility and does not cause siltation in the bottom of the facility. On a case-by-case basis, the City may require a specific construction schedule be supplied to ensure the infiltration facility will function appropriately when brought online. The following practices are recommended:

- Excavate to within one foot of the final elevation of the basin floor. Excavate to final grade only after all disturbed areas have been permanently stabilized. The final phase of excavation should remove any accumulation of fine particles before putting the facility into service.
- Do not use infiltration facilities as temporary sediment traps or ponds during construction.
- Keep heavy equipment away from excavated infiltration facility area.

#### **7.7.1.5 Infiltration Facility Maintenance**

Per Minimum Requirement #9, an operation and maintenance plan shall be prepared for all stormwater management facilities. See Volume 1, Appendix C for specific maintenance requirements. Maintenance shall be a basic consideration in design and cost-determination of the stormwater management facility.

Any standing water removed during the maintenance operation must be disposed of in a City approved manner. See the dewatering requirements in Volume 4, Appendix D of this manual. Pretreatment may be necessary. Solids must be disposed in accordance with state and local waste regulations.

Facilities shall be designed and constructed such that the facility can be safely and easily inspected by one person and safely and easily maintained. This may require construction of additional inspection ports or access manholes to allow inspection access to be opened by one person.

#### **7.7.1.6 Infiltration Facility Easements**

See Volume 3, Chapter 13 for information concerning easements.

### **7.7.2 BMP T710 Infiltration Basins**

#### **7.7.2.1 Description**

Infiltration basins are earthen impoundments used for the collection, temporary storage and infiltration of incoming stormwater runoff.

#### **7.7.2.2 Design Criteria Specific for Basins**

- Access should be provided for vehicles to easily maintain the forebay (presettling basin) area and not disturb vegetation, or resuspend sediment any more than is absolutely necessary.
- The slope of the basin bottom should not exceed 3% in any direction.
- A minimum of one foot of freeboard is recommended when establishing the design ponded water depth. Freeboard is measured from the rim of the infiltration facility to the maximum ponding level or from the rim down to the overflow point if overflow or a spillway is included.
- Erosion protection of inflow points to the basin must also be provided (e.g., riprap, flow spreaders, energy dissipators (See Volume 3, Chapter 3). Select suitable vegetative

materials for the basin floor and side slopes to be stabilized. Refer to Volume 5, Chapter 7 for recommended vegetation.

- Lining material – Basins can be open or covered with a 6 to 12-inch layer of filter material such as coarse sand, or a suitable filter fabric to help prevent the buildup of impervious deposits on the soil surface. A nonwoven geotextile should be selected that will function sufficiently without plugging (see geotextile specifications in Appendix B of Volume 5). The filter layer can be replaced or cleaned when/if it becomes clogged.
- Vegetation – The embankment, emergency spillways, spoil and borrow areas, and other disturbed areas should be stabilized and planted, preferably with grass, in accordance with the Stormwater Site Plan (See Minimum Requirement #1 of Volume 1). Without healthy vegetation the surface soil pores would quickly plug.
- Ponds shall have a sign placed for maximum visibility from adjacent streets, sidewalks, and paths. An example and specifications for ponds is provided in Volume 3 Section 7.2.2.9; Figure 3 - 18 and Table 3 - 9.

### **7.7.3 BMP T720 Infiltration Trenches**

#### **7.7.3.1 Description**

Infiltration trenches are generally at least 24 inches wide, and are backfilled with a coarse stone aggregate, allowing for temporary storage of stormwater runoff in the voids of the aggregate material. Stored runoff gradually infiltrates into the surrounding soil. The surface of the trench can be covered with grating and/or consist of stone, gabion, sand, or a grassed covered area with a surface inlet. Perforated rigid pipe of at least 8-inch diameter can also be used to distribute the stormwater in a stone trench.

#### **7.7.3.2 Design Criteria**

Due to accessibility and maintenance limitations, infiltration trenches must be carefully designed and constructed.

Infiltration trenches may be placed in fill material if the fill is placed and compacted under the direct supervision of a geotechnical engineer or professional civil engineer with geotechnical expertise, and if the measured infiltration rate is at least 8 inches per hour.

The base of the infiltration facility shall be level.

##### **7.7.3.2.1 Cleanouts/Access Ports**

Install cleanouts and/or access ports to allow cleaning and inspection of the system.

##### **7.7.3.2.2 Backfill Material**

The aggregate material for the infiltration trench shall consist of a clean aggregate with a maximum diameter of 3 inches and a minimum diameter of 1.5 inches. Void space for these aggregates shall be in the range of 30 to 40 percent.

##### **7.7.3.2.3 Geotextile Fabric Liner**

The aggregate fill material shall be completely encased in an engineering geotextile material. Geotextile should surround all of the aggregate fill material except for the top one-foot, which is placed over the geotextile. Geotextile fabric with acceptable properties must be carefully selected to avoid plugging (see Appendix B of Volume 5).

The bottom sand or geotextile fabric is optional.

*Refer to the Federal Highway Administration Manual "Geosynthetic Design and Construction Guidelines," Publication No. FHWA HI-95-038, May 1995 for design guidance on geotextiles in drainage applications. Refer to the NCHRP Report 367, "Long-Term Performance of Geosynthetics in Drainage Applications," 1994, for long-term performance data and background on the potential for geotextiles to clog, blind, or to allow piping to occur and how to design for these issues.*

#### **7.7.3.2.4 Overflow Channel**

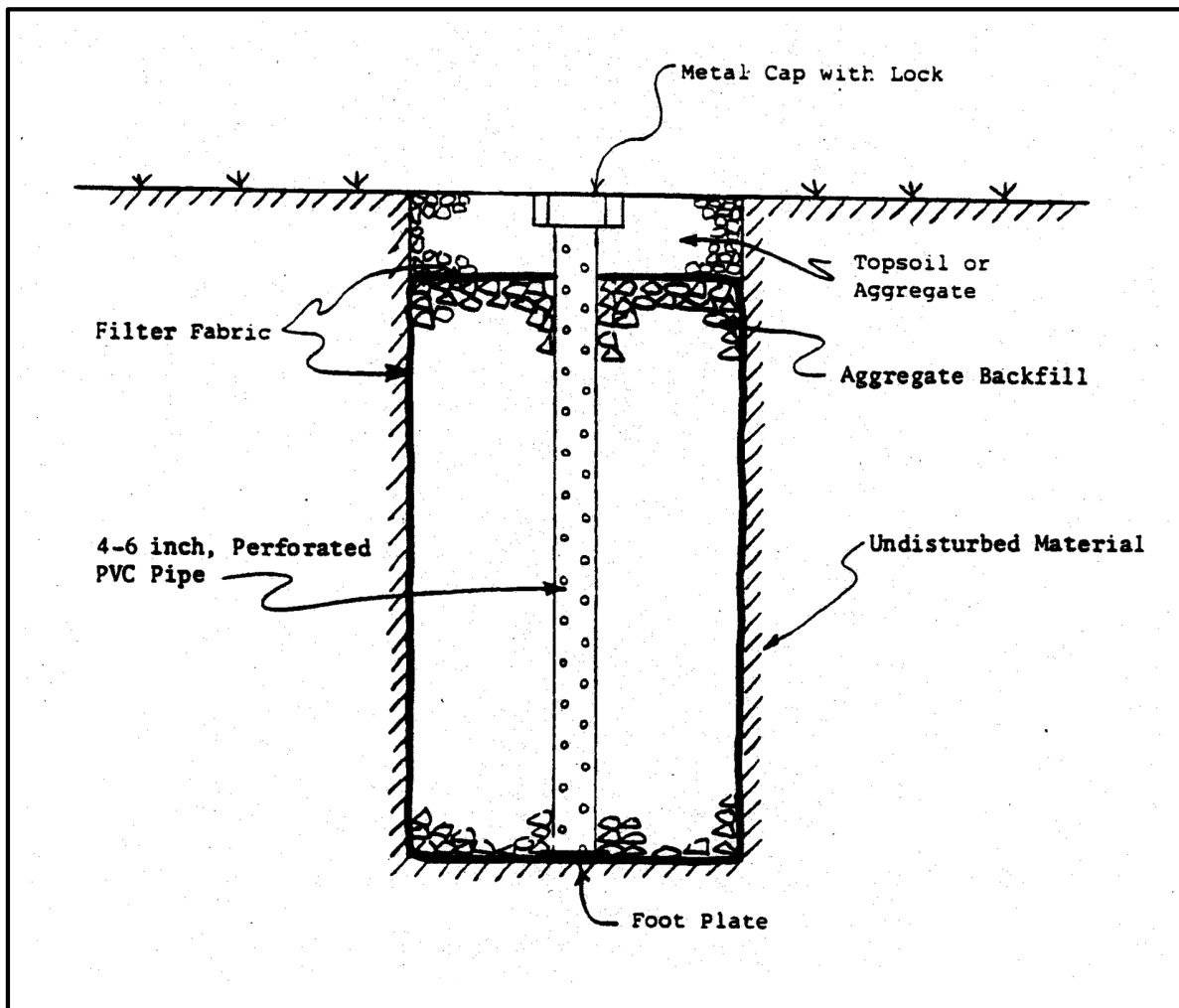
Because an infiltration trench is generally used for small drainage areas, an emergency spillway is not necessary. However, a non-erosive overflow channel leading to a stabilized watercourse or other Environmental Services approved location should be provided.

#### **7.7.3.2.5 Surface Cover**

A stone filled trench can be placed under a porous or impervious surface cover to conserve space.

#### **7.7.3.2.6 Observation Well**

An observation well should be installed at the lower end of the infiltration trench to check water levels, drawdown time, sediment accumulation, and conduct water quality monitoring. Figure 5 - 7 illustrates observation well details. It should consist of a perforated PVC pipe which is 4 to 6 inches in diameter and it should be constructed flush with the ground elevation. For larger trenches, a 12-36 inch diameter well can be installed to facilitate maintenance operations such as pumping out the sediment. The top of the well should be capped to discourage vandalism and tampering.



*Figure 5 - 7. Observation Well Details*

#### **7.7.3.2.7 Pipe**

- Distribution pipe shall be level and shall be either perforated or slotted pipe.
- Perforated pipe shall conform to WSDOT specification 9-05.2.
- Slotted pipe shall have slots cut perpendicular to the long axis of the pipe and be 0.04 to 0.069 inches by 1 inch long and be spaced 0.25 inches apart longitudinally.
- Distribution pipe shall be a minimum of 8 inches in diameter.

#### **7.7.3.3 Construction Criteria**

- **Trench Preparation** – Place excavated materials away from the trench sides to enhance trench wall stability. Keep excavated material away from slopes, neighboring property, sidewalks and streets.
- **Stone Aggregate Placement and Compaction** – Place the stone aggregate in lifts and compact using plate compactors. As a rule of thumb, a maximum loose lift thickness of 12 inches is recommended. The compaction process ensures geotextile conformity to the



excavation sides, thereby reducing potential piping and geotextile clogging, and settlement problems.

- **Potential Contamination** - Prevent natural or fill soils from intermixing with the stone aggregate. Remove all contaminated stone aggregate and replace with uncontaminated stone aggregate.
- **Overlapping and Covering** - Following the stone aggregate placement, fold the geotextile over the stone aggregate to form a 12 inch minimum longitudinal overlap. When overlaps are required between rolls, overlap the upstream roll a minimum of 2 feet over the downstream roll in order to provide a shingled effect.
- **Voids behind Geotextile** – Avoid voids between the geotextile and excavation sides. Remove boulders or other obstacles from the trench walls. Place natural soils in voids at the most convenient time during construction to ensure geotextile conformity to the excavation sides. Soil piping, geotextile clogging, and possible surface subsidence will be avoided by this remedial process.
- **Unstable Excavation Sites** - Vertically excavated walls may be difficult to maintain in areas where the soil moisture is high or where soft or cohesionless soils predominate. Trapezoidal, rather than rectangular, cross-sections may be needed.

## Chapter 8 Sand Filtration Treatment Facilities

### 8.1 Purpose

This chapter presents criteria for the design, construction and maintenance of runoff treatment sand filters. Treatment sand filters are used to collect, treat and remove TSS, phosphorous, and insoluble organics (including oils) from stormwater.

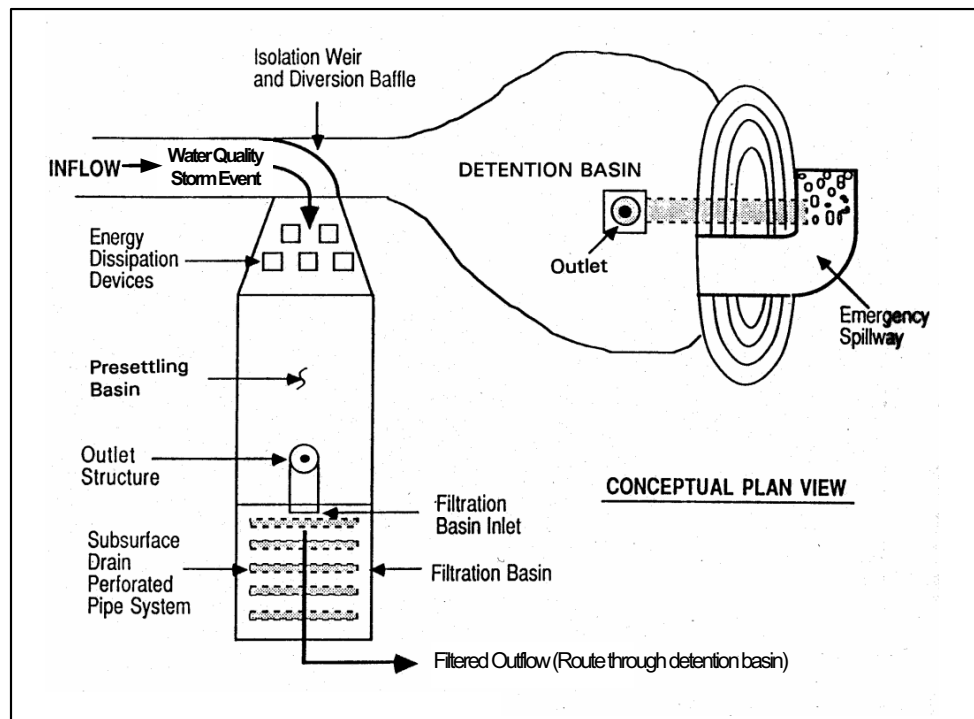
Sand filtration options discussed in this Chapter are:

- BMP T810 Sand Filter Vault
- BMP T820 Linear Sand Filter
- Basic Sand Filter
- Large Sand Filter

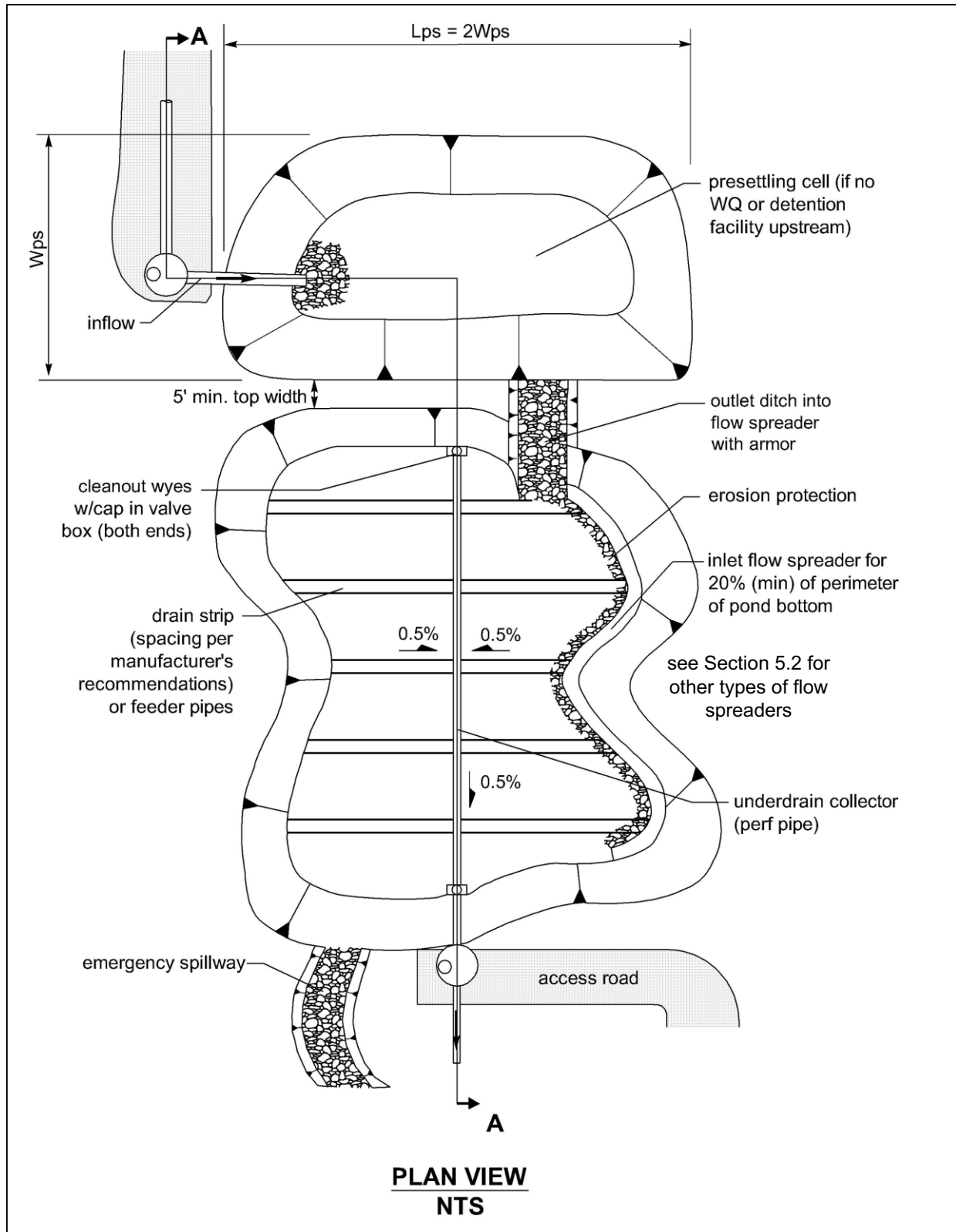
### 8.2 Description

A typical sand filtration system consists of a pretreatment facility, flow spreader(s), a sand bed, and the underdrain piping. The sand filter bed includes a geotextile fabric between the sand bed and the bottom underdrain system.

An impermeable liner under the facility may also be needed if the filtered runoff requires additional treatment to remove soluble groundwater pollutants, or in cases where additional groundwater protection is mandated. The variations of a sand filter include a basic or large sand filter, sand filter with level spreader, sand filter vault, and linear sand filter. Figure 5 - 8 through Figure 5 - 15 provide examples of various sand filter configurations.



**Figure 5 - 8. Sand Filtration Basin Preceded by Presettling Basin  
(Variation of a Basic Sand Filter)**



**Figure 5 - 9. Sand Filter with a Pretreatment Cell (top view)**

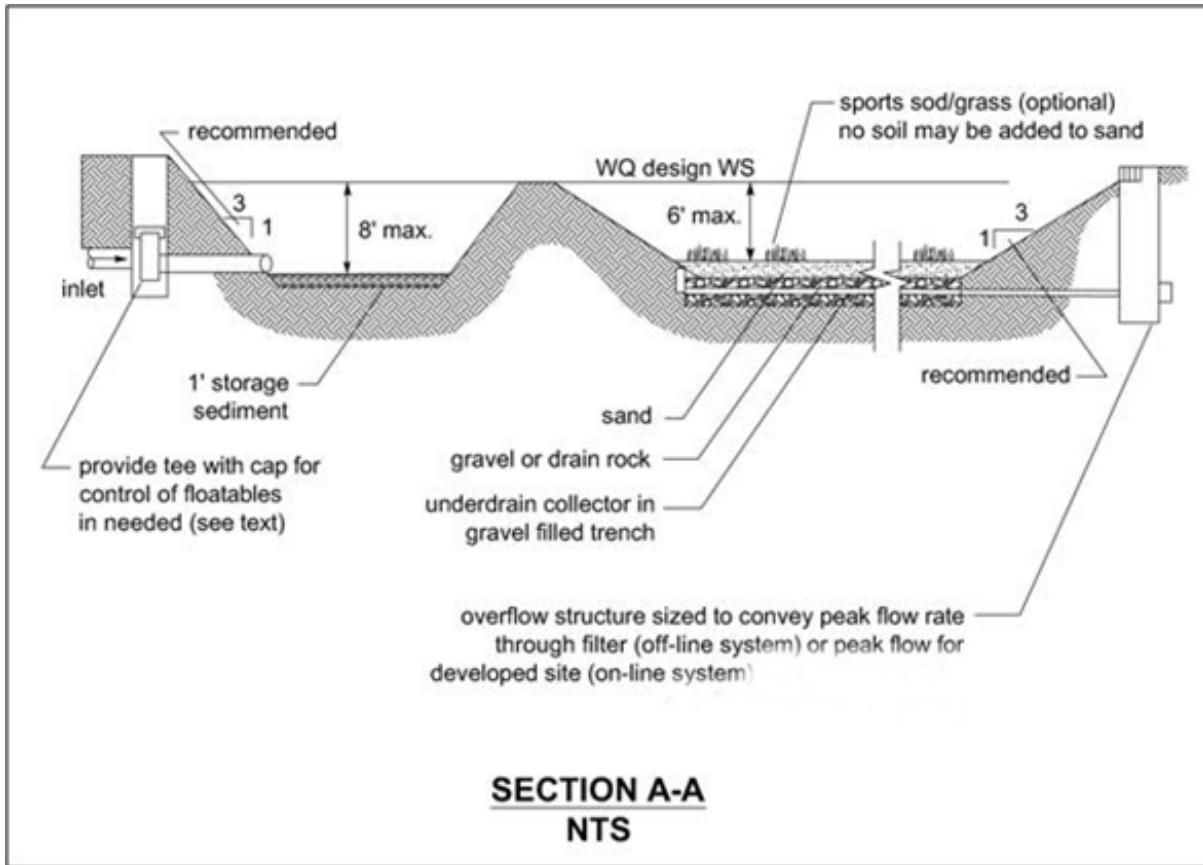
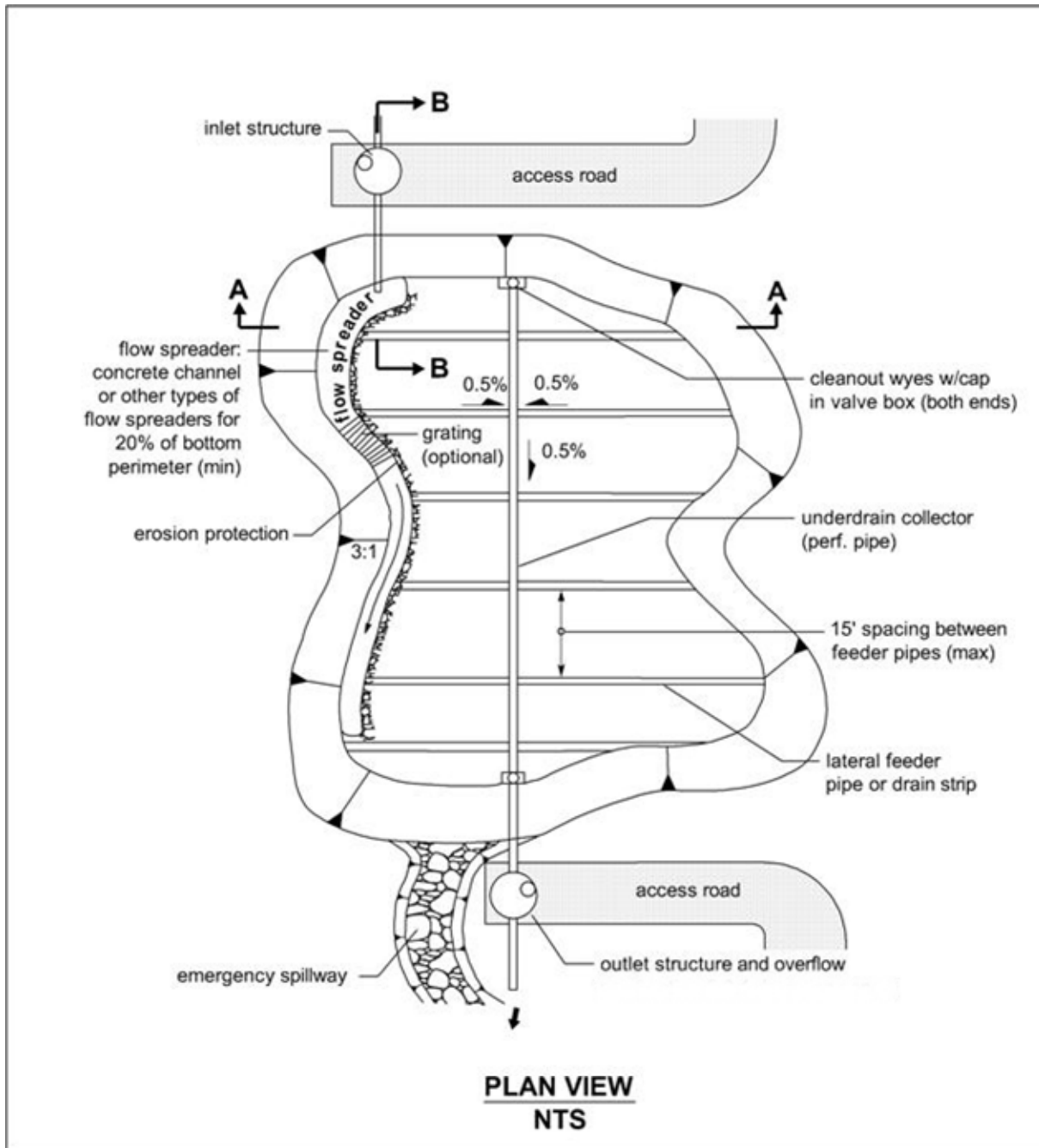


Figure 5 - 10. Sand Filter with a Pretreatment Cell (side view)



**Figure 5 - 11. Sand Filter with Level Spreader (top view)**

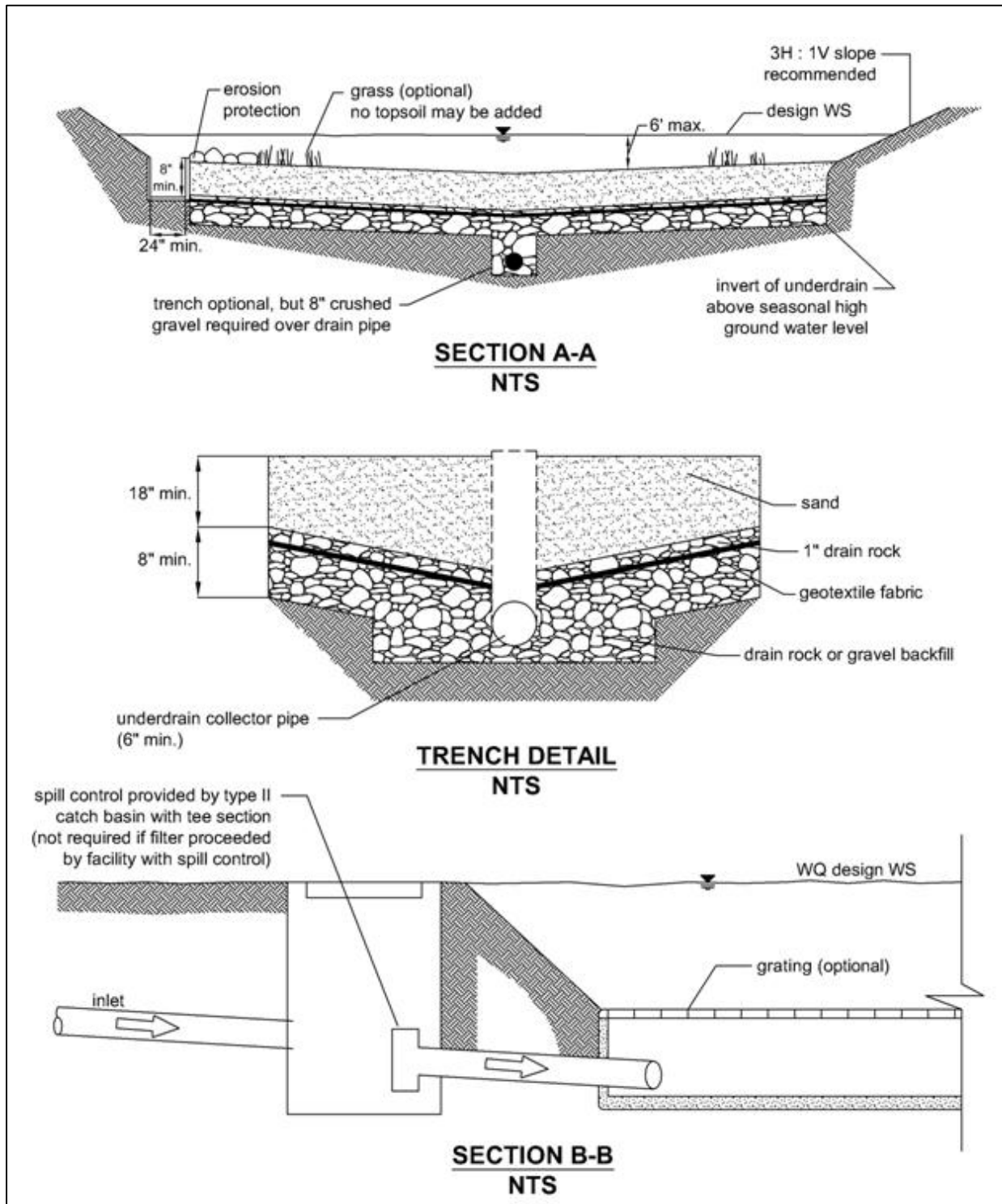


Figure 5 - 12. Sand Filter with Level Spreader (side view)

## 8.3 Applications and Limitations

Sand filtration can be used in most residential, commercial, and industrial developments where debris, heavy sediment loads, and oils and greases will not clog or prematurely overload the sand, or where adequate pretreatment is provided for these pollutants.

Pretreatment is necessary to reduce velocities to the sand filter and remove debris, floatables, large particulate matter, and oils. In high water table areas, adequate drainage of the sand filter may require additional engineering analysis and design considerations. An underground filter should be considered in areas subject to freezing conditions. (Urbonas, 1997)

## 8.4 Site Suitability

The following site characteristics should be considered in siting a sand filtration system:

- Space availability, including the space needed for a presettling basin.
- Sufficient hydraulic head, at least 4 feet from inlet to outlet.
- Adequate Operation and Maintenance capability including accessibility for O & M.
- Sufficient pretreatment of oil, debris and solids in the tributary runoff.

## 8.5 Design Criteria

### 8.5.1 Sand Filter Design Criteria and Sizing

Sand filter design criteria are as follows:

1. Sand filters shall be sized to capture and treat the water quality design volume, which is 91% of the total runoff volume as predicted by WWHM.
2. The design hydraulic conductivity shall be 1 in/hr.
3. **Online** sand filters must NOT be placed **upstream** of a detention facility. This is to prevent exposure of the sand filter surface to high flow rates that could cause loss of media and previously removed pollutants.
4. **Online** sand filters placed **downstream** of a detention facility must be sized using WWHM to filter the water quality design volume.
5. **Offline** sand filters placed **upstream** of a detention facility must have a flow splitter designed to send all flows at or below the 15-minute water quality flow rate, as predicted by WWHM to the sand filter. The sand filter must be sized to filter all the runoff sent to it (no overflows from the treatment facility should occur).
6. **Offline** sand filters placed **downstream** of a detention facility must have a flow splitter designed to send all flows at or below the 2-year return period flowrate as estimated by WWHM, from the detention facility to the treatment facility. The treatment facility must be sized to filter all the runoff sent to it (no overflows from the treatment facility should occur).
7. Include an overflow in the design. The overflow height shall be at the maximum hydraulic head of the water above the sand bed.
8. Pretreat runoff to be treated by the sand filter (e.g., presettling basin, etc. depending on pollutants) to remove debris and other solids, and oil from high use sites.

9. Design inlet bypass and flow spreading structures (e.g., flow spreaders, weirs or multiple orifice openings) to capture the applicable design flow rate, minimize turbulence and to spread the flow uniformly across the surface of the sand filter. Install stone riprap or other energy dissipation devices to prevent gouging of the sand medium and to promote uniform flow. Include emergency spillway or overflow structures (see Volume 3).
  - If the sand filter is curved or an irregular shape, provide a flow spreader for a minimum of 20% of the filter perimeter.
  - If the length-to-width ratio of the filter is 2:1 or greater, locate a flow spreader on the longer side of the filter and for a minimum length of 20% of the facility perimeter.
  - Provide erosion protection along the first foot of the sand bed adjacent to the flow spreader. Methods for this include geotextile weighted with sand bags at 15-foot intervals and quarry spalls.
10. Include underdrain piping in sand filter design. Types of underdrains include a central collector pipe with lateral feeder pipes; or a geotextile drain strip in an 8-inch gravel backfill or drain rock bed; or longitudinal pipes in an 8-inch gravel backfill or drain rock with a collector pipe at the outlet end.
  - Upstream of detention, underdrain piping shall be sized to handle double the two-year return frequency flow indicated by the WWHM (the doubling factor is a factor of safety). Downstream of detention the underdrain piping shall be sized for the two-year return frequency flow indicated by the WWHM. In both instances there shall be at least one foot of hydraulic head above the invert of the upstream end of the collector pipe.
  - Internal diameters of underdrain pipes shall be a minimum of six inches having two rows of ½-inch holes spaced 6 inches apart longitudinally (maximum), with rows 120 degrees apart (laid with holes downward). Maximum perpendicular distance between two feeder pipes or the edge of the filter and a feeder pipe, must be 15 feet. All piping is to be schedule 40 PVC or greater wall thickness. Drain piping could be installed in basin and trench configurations. Other equivalent underdrains can be used.
  - Main collector underdrain pipe shall be at a slope of 0.5 percent minimum.
  - A geotextile fabric (specifications in Appendix B) must be used between the sand layer and drain rock or gravel and placed so that 1-inch of drain rock/gravel is above the fabric. Drain rock shall be 0.75-1.5 inch rock or gravel backfill, washed free of clay and organic material.
11. Provide cleanout wyes with caps or junction boxes at both ends of the collector pipes. Extend cleanouts to the surface of the filter. Provide a valve box for access to the cleanouts. Provide access for cleaning all underdrain piping. This may consist of installing cleanout ports that tee into the underdrain system and surface above the top of the sand bed. To facilitate maintenance of the sand filter an inlet shutoff/bypass valve is recommended.
12. Sand specification: The sand in a filter shall be a minimum 18" in depth and must meet the size gradation (by weight) given in Table 5 - 7. The contractor must obtain a grain size analysis from the supplier to certify that the sieve requirements are met.



**Table 5 - 7: Sand Specifications<sup>a</sup>**

U.S. Sieve Number	Percent Passing
4	95-100
8	70-100
16	40-90
30	25-75
50	2-25
100	<4
200	<2

a. Source: King County Stormwater Design Manual, September 1998

13. Impermeable Liners for Sand Bed Bottom: Impermeable liners are generally required for soluble pollutants such as metals and toxic organics and where the underflow could cause problems with structures. Impermeable liners may be made of clay, concrete or geomembrane. Clay liners shall have a minimum thickness of 12 inches and meet the specifications given in Table 5 - 8.

**Table 5 - 8: Clay Liner Specifications<sup>a</sup>**

Property	Test Method	Unit	Specification
Permeability	ASTM D-2434	cm/sec	$1 \times 10^{-6}$ max.
Plasticity Index of Clay	ASTM D-423 & D-424	percent	Not less than 15
Liquid Limit of Clay	ASTM D-2216	percent	Not less than 30
Clay Particles Passing	ASTM D-422	percent	Not less than 30
Clay Compaction	ASTM D-2216	percent	95% of Standard Proctor Density

a. Source: City of Austin, 1988

- If a geomembrane liner is used it shall have a minimum thickness of 30 mils and be ultraviolet light resistant. The geomembrane liner shall be protected from puncture, tearing, and abrasion by installing geotextile fabric on the top and bottom of the geomembrane.
- Concrete liners may also be used for sedimentation chambers and for sedimentation and sand filtration basins less than 1,000 square feet in area. Concrete shall be 5 inches thick Class A or better and shall be reinforced by steel wire mesh. The steel wire mesh shall be 6 gauge wire or larger and 6-inch by 6-inch mesh or smaller. An "Ordinary Surface Finish" is required. When the underlying soil is clay or has an unconfined compressive strength of 0.25 ton per square foot or less, the concrete shall have a minimum 6-inch compacted aggregate base. This base must consist of coarse sand and river stone, crushed stone or equivalent with diameter of 0.75- to 1-inch.

- If an impermeable liner is not required then a geotextile fabric liner shall be installed that retains the sand and meets the specifications listed in Appendix B unless the basin has been excavated to bedrock.
  - If an impermeable liner is not provided, then an analysis shall be made of possible adverse effects of seepage zones on groundwater, and near building foundations, basements, roads, parking lots and sloping sites. Sand filters without impermeable liners shall not be built on fill sites and shall be located at least 20-feet downslope and 100-feet upslope from building foundations.
14. Include an access ramp with a slope not to exceed 7H:1V, or equivalent, for maintenance purposes at the inlet and the outlet of a surface filter.
  15. Side slopes for earthen/grass embankments shall not exceed 3H:1V to facilitate mowing.
  16. There shall be at least 2 feet clearance between the seasonal high groundwater level and the bottom of the sand filter.

## 8.6 Construction Criteria

- The sand filter shall not be placed into service until site construction is complete and the site is stabilized.
- Place sand in a uniform thickness and compact using a water settling method. Settling shall be accomplished by flooding the sand with 10-15 gallons of water per cubic foot of sand. After flooding, the sand shall be smoothed and leveled.

## 8.7 Maintenance Criteria

Per Minimum Requirement #9, an operation and maintenance plan shall be prepared for all stormwater management facilities. See Volume 1, Appendix C, Maintenance Checklist #15 and #16 for specific maintenance requirements for sand filters. Maintenance shall be a basic consideration in design and cost-determination of the stormwater management facility.

Any standing water removed during maintenance operation must be disposed of in a City approved manner. See the dewatering requirements in Volume 4, Appendix D of this manual. Pretreatment may be necessary. Solids must be disposed of in accordance with state and local waste regulations.

Facilities shall be designed and constructed such that the facility can be safely and easily inspected by one person and safely and easily maintained. This may require construction of additional inspection ports or access manholes to allow inspection access to be opened by one person.

## 8.8 BMP T808 Basic Sand Filter

See Section 8.5 to 8.7 for design criteria for basic sand filters; there are no additional design criteria.

## 8.9 BMP T809 Large Sand Filter

### 8.9.1 Additional Large Sand Filter Design Criteria

- Large sand filters shall be sized to capture and treat 95% of the runoff volume.

- Large sand filter underdrains and overflows shall be designed by increasing the 2-year return period flowrate by the ratio of the 95% runoff volume and the 91% runoff volume.

$$\text{Design flowrate for overflow or underdrain} = \left( \frac{95\% \text{ runoff volume}}{91\% \text{ runoff volume}} \right) * 2 \text{ year return period flowrate}$$

## 8.10 BMP T810 Sand Filter Vault

### 8.10.1 Description (Figure 5 - 13 and Figure 5 - 14)

A sand filter vault is similar to an open sand filter except that the sand layer and underdrains are installed below grade in a vault. It consists of presettling and sand filtration cells.

### 8.10.2 Applications and Limitations

- Use where space limitations preclude above ground facilities
- Not suitable where high water table and heavy sediment loads are expected
- An elevation difference of 4 feet between inlet and outlet is needed

### 8.10.3 Additional Design Criteria for Vaults

- Optimize sand inlet flow distribution with minimal sand bed disturbance. A maximum 8-inch distance between the top of the spreader and the top of the sand bed is required. Flows may enter the sand bed by spilling over the top of the wall into a flow spreader pad or alternatively a pipe and manifold system may be used. Any pipe and manifold system must retain the required dead storage volume in the first cell, minimize turbulence, and be readily maintainable.
- If an inlet pipe and manifold system is used, the minimum pipe size shall be 8 inches. Multiple inlets are required to minimize turbulence and reduce local flow velocities.
- Provide erosion protection along the first foot of the sand bed adjacent to the spreader. Geotextile fabric secured on the surface of the sand bed, or equivalent method, may be used.
- Design the presettling cell for sediment collection and removal. Use a V-shaped bottom, removable bottom panels, or equivalent sludge handling system. Provide one-foot of sediment storage in the presettling cell.
- Seal the pre-settling chamber to trap oil and trash. This chamber is usually connected to the sand filtration chamber using a pipe with an inverted elbow to protect the filter surface from oil and trash.
- If a retaining baffle is necessary for oil/floatables in the presettling cell, it must extend at least one foot above to one foot below the design flow water level. Provide provision for the passage of flows in the event of plugging. Provide access opening and ladder on both sides of the baffle.
- To prevent anoxic conditions, provide a minimum of 24 square feet of ventilation grate for each 250 square feet of sand bed surface area. For sufficient distribution of airflow across the sand bed, grates may be located in one area if the sand filter is small, but placement at each end is preferred. Small grates may also be dispersed over the entire sand bed area.

- Sand filter vaults must conform to the materials, structural suitability, and access criteria specified for wet vaults in Chapter 8.
- Provide a sand filter inlet shutoff/bypass valve for maintenance
- A geotextile fabric over the entire sand bed may be installed that is flexible, highly permeable, three-dimensional matrix, and adequately secured. This is useful in trapping trash and litter.

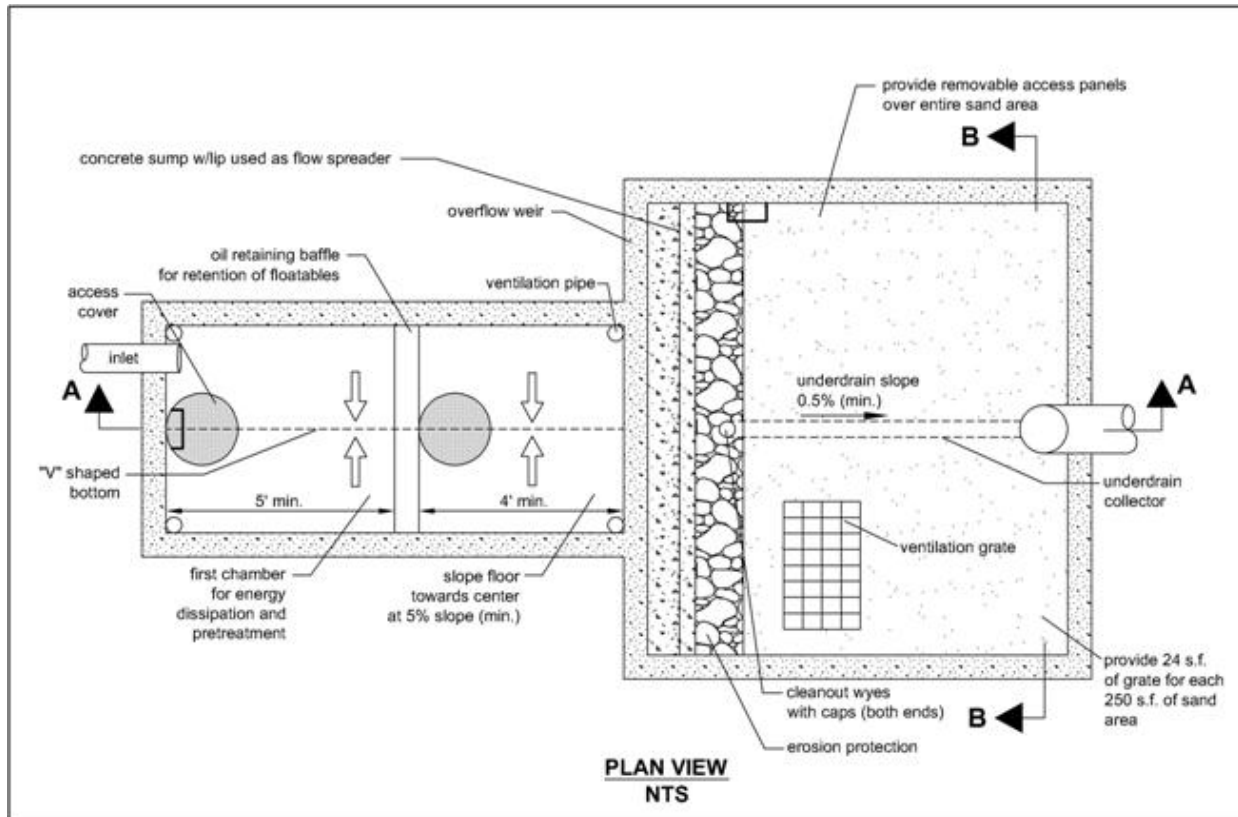


Figure 5 - 13. Sand Filter Vault (top view)

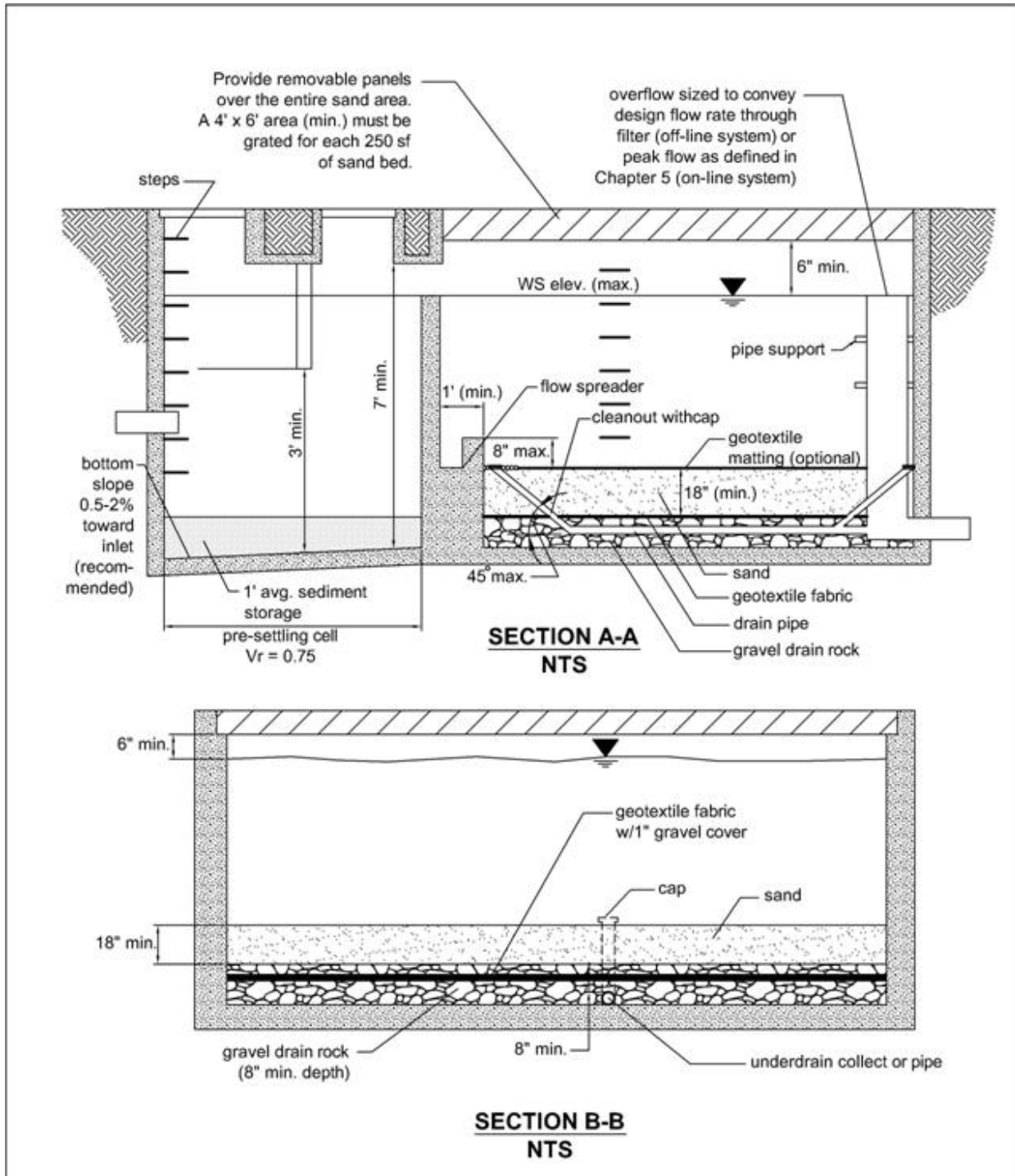


Figure 5 - 14. Sand Filter Vault (side view)

## 8.11 BMP T820 Linear Sand Filter

### 8.11.1 Description

Linear sand filters are typically long, shallow, two-celled, rectangular vaults. The first cell is designed for settling coarse particles, and the second cell contains the sand bed. Stormwater enters the second cell via a weir section that also functions as a flow spreader.

Figure 5 - 15 illustrates a linear sand filter.

### 8.11.2 Application and Limitations

- Applicable in long narrow spaces such as the perimeter of a paved surface.
- As a part of a treatment train such as downstream of a filter strip, upstream of an infiltration system, or upstream of a wet pond or a biofilter for oil control.
- To treat small drainages (less than 2 acres of impervious area).
- To treat runoff from high-use sites for TSS and oil/grease removal, if applicable.

### 8.11.3 Additional Design Criteria for Linear Sand Filters

- Divide the two cells by a divider wall that is level and extends a minimum of 12 inches above the sand bed.
- Stormwater may enter the sediment cell by sheet flow or a piped inlet.
- The width of the sand cell must be 1-foot minimum to 15 feet maximum.
- The sand filter bed must be a minimum of 12 inches deep and have an 8-inch layer of drain rock with perforated drainpipe beneath the sand layer.
- The drainpipe must be 6-inch diameter minimum and be wrapped in geotextile and sloped a minimum of 0.5 percent to promote positive drainage.
- Maximum sand bed ponding depth: 12 inches.
- Must be vented as described above for sand filter vaults.
- Linear sand filters must conform to the materials and structural suitability criteria specified for wet vaults described in Chapter 8.
- Sediment cell width shall be selected based on sand filter width as follows:

Sand filter width, (w) inches	12-24	24-48	48-72	72+
Sediment cell width, inches	12	18	24	w/3

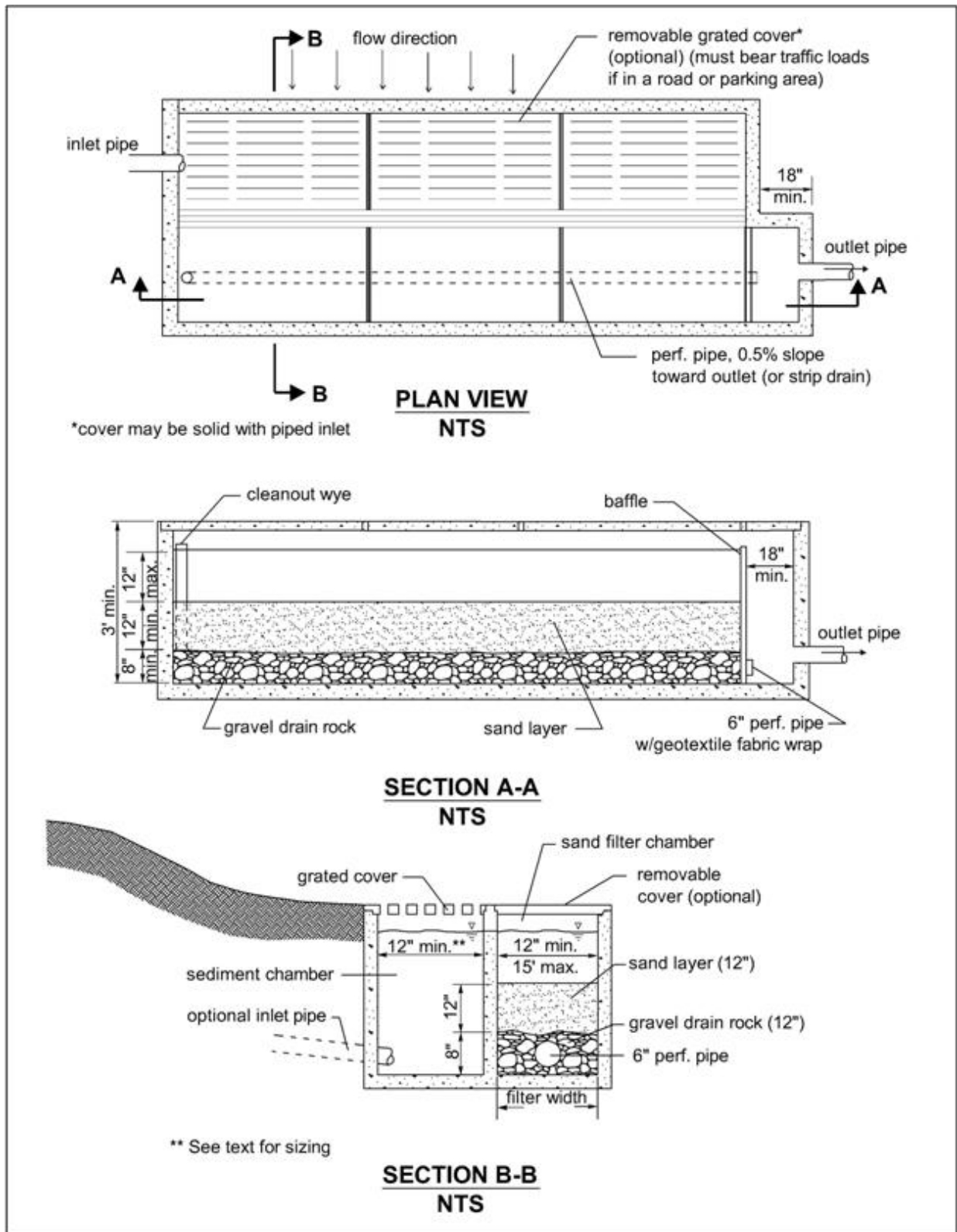


Figure 5 - 15. Linear Sand Filter

## **Chapter 9 Media Filter Drain (previously Ecology Embankment) – BMP T900**

The media filter drain (MFD), previously referred to as the ecology embankment, is a linear flow-through stormwater runoff treatment device that can be sited along highway side slopes (conventional design) and medians (dual media filter drains), borrow ditches, or other linear depressions.

The media filter drain can achieve basic, phosphorus, and enhanced water quality treatment.

Design and sizing criteria can be found in Chapter 5 of the most recent version of Highway Runoff Manual, available at <http://www.wsdot.wa.gov/environment/waterquality/runoff/highwayrunoffmanual.htm>.



**This Page Intentionally Left Blank**

## **Chapter 10 Biofiltration Treatment Facilities**

### **10.1 Purpose**

This Chapter addresses five Best Management Practices (BMPs) that are classified as biofiltration treatment facilities.

Biofilters are vegetated treatment systems (typically grass) that remove pollutants by means of sedimentation, filtration, soil sorption, and/or plant uptake. They are typically configured as swales or flat filter strips.

The BMPs discussed in this chapter are designed to remove low concentrations and quantities of total suspended solids (TSS), heavy metals, petroleum hydrocarbons, and/or nutrients from stormwater.

### **10.2 Applications**

A biofilter can be used as a basic treatment BMP for stormwater runoff from roadways, driveways, parking lots, and highly impervious ultra-urban areas or as the first stage of a treatment train. In cases where hydrocarbons, high TSS concentrations, or debris would be present in the runoff, such as high-use sites, a pretreatment system or oil treatment for those components is necessary. Placement of the biofilter in an offline location is preferred to avoid flattening of the vegetation and the erosive effects of high flows.

### **10.3 Site Suitability**

The following factors must be considered for determining site suitability:

- Accessibility for operation and maintenance.
- Suitable growth environment (soil, exposure to sunlight, etc.) for the vegetation.
- Adequate siting for a pre-treatment facility if high petroleum hydrocarbon levels (oil/grease) or high TSS loads could impair treatment capacity or efficiency.

### **10.4 Best Management Practices**

The following five Biofiltration Treatment Facilities BMPs are discussed in this chapter:

BMP T1010 – Basic Biofiltration Swale

BMP T1020 – Wet Biofiltration Swale

BMP T1030 – Continuous Inflow Biofiltration Swale

BMP T1040 – Basic Filter Strip

BMP T1050 – Compost – Amended Vegetated Filter Strip

## 10.4.1 BMP T1010 Basic Biofiltration Swale

### 10.4.1.1 Description

Biofiltration swales are typically shaped as a trapezoid or a parabola in cross section as shown in Figure 5 - 16 and Figure 5 - 17.

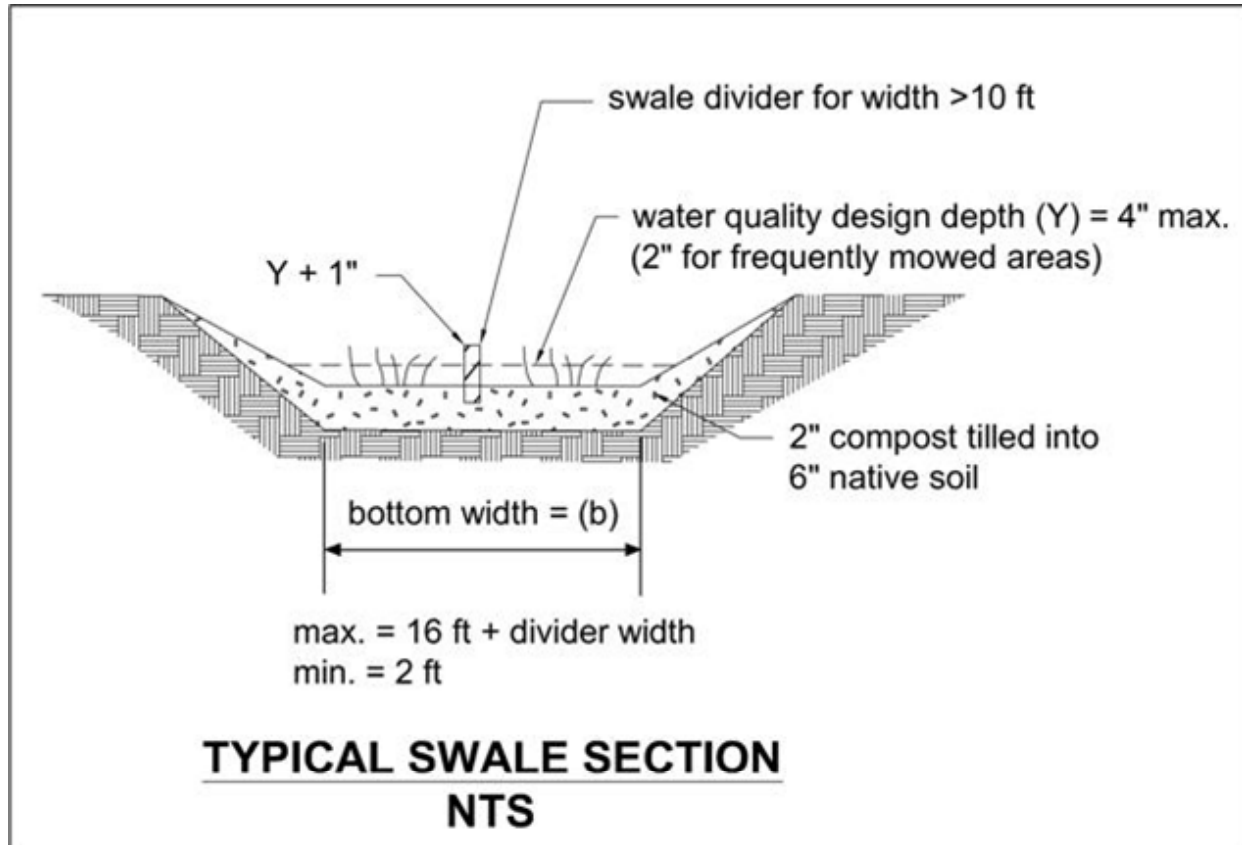
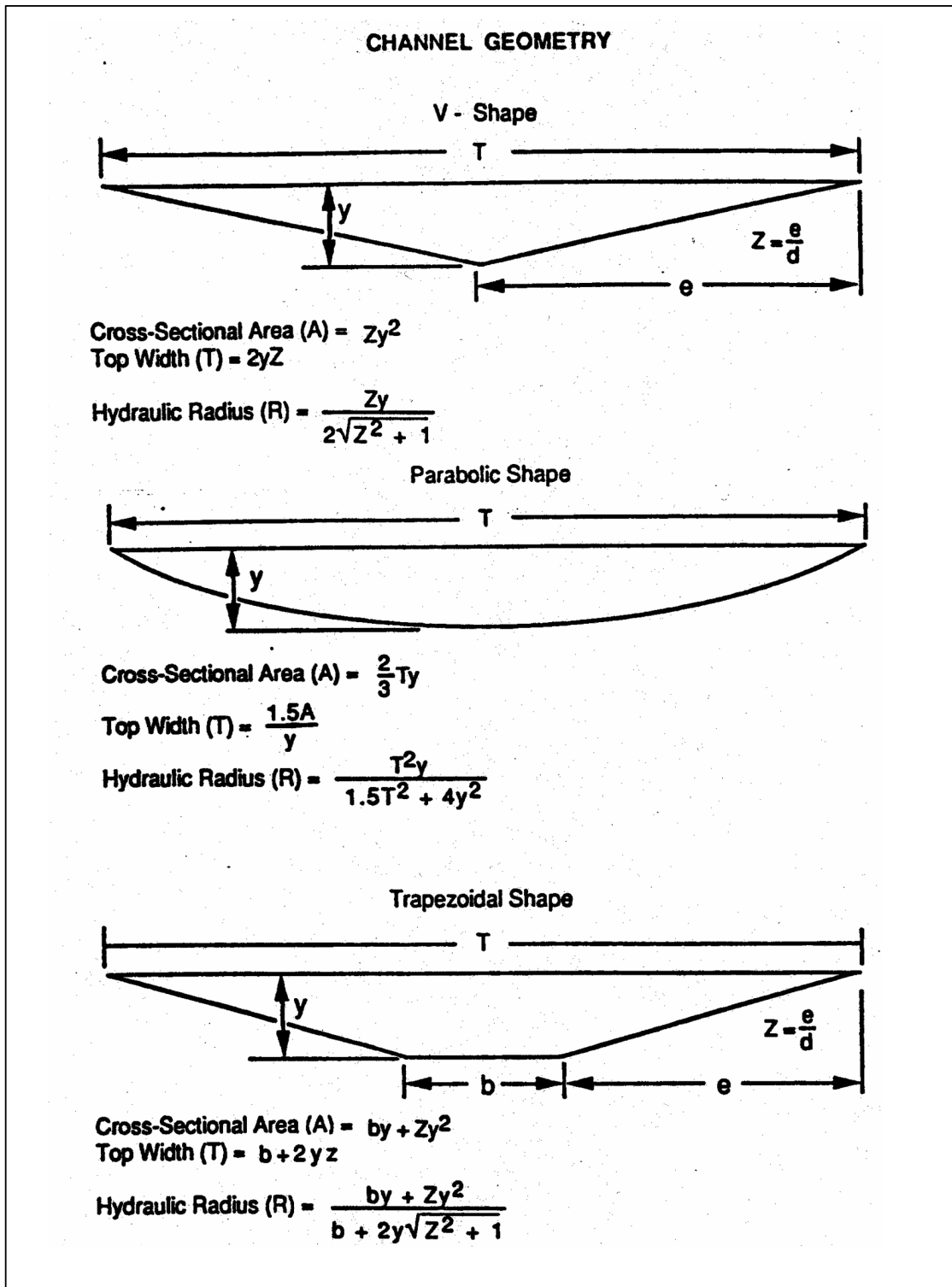


Figure 5 - 16. Typical Swale Section

### 10.4.1.2 Design Criteria

- Size the swale using sizing criteria specified in Table 5 - 9. Minimum length shall be 100 feet.
- Check the hydraulic capacity/stability using  $Q_{\max}$ .
- Select a vegetation cover suitable for the site. Refer to Table 5 - 12 through Table 5 - 14.
- Install level spreaders (minimum 1 inch gravel) at the head of all swales, and every 50 feet in swales of  $\geq 4$  feet width. Include sediment cleanouts (weir, settling basin, or equivalent) at the head of the biofilter as needed.
- Use energy dissipaters (such as quarry spalls or riprap) as necessary. See Volume 3 for additional information.



Source: Livingston, et al, 1984

**Figure 5 - 17. Geometric Formulas for Common Swale Shapes**

**Table 5 - 9: Sizing Criteria**

Design Parameter	BMP T1010 - Biofiltration Swale
Longitudinal Slope <sup>a</sup>	0.015 - 0.025
Maximum velocity <sup>b</sup>	1 ft / sec @ K multiplied by the WQ design flow rate
Maximum velocity for channel stability <sup>c</sup>	3 ft/sec
Maximum water depth <sup>d</sup>	2"- if mowed frequently; 4" if mowed infrequently
Manning coefficient <sup>e</sup>	(0.2 – 0.3) (0.24 if mowed infrequently)
Bed width (bottom) <sup>f</sup>	(2 - 10 ft)
Freeboard height	0.5 ft
Minimum hydraulic residence time at K multiplied by Water Quality Design Flow Rate	9 minutes (18 minutes for continuous inflow)
Minimum length	100 ft
Maximum sideslope	3 H:1 V 4H:1V preferred
Max. tributary drainage flowpath	---
Max. longitudinal slope of contributing area	---
Max lateral slope of contributing area	

a. For swales, if the slope is less than 1.5% install an underdrain using a perforated pipe, or equivalent. Amend the soil if necessary to allow effective percolation of water to the underdrain. Install the low-flow drain 6" deep in the soil. Slopes greater than 2.5% need check dams (riprap) at vertical drops of 12-15 inches. Underdrains can be made of 6 inch Schedule 40 PVC perforated pipe or equivalent with 6" of drain gravel on the pipe. The gravel and pipe must be enclosed by geotextile fabric (see Figure 5 - 19 and Figure 5 - 20).

b.  $K=A$  ratio of the peak 10-minute flow predicted by SBUH to the water quality design flow rate estimated using the WWHM. The value of K for offline systems is 3.5, and for online systems is 2.0 in the City of Tacoma.

c. Maximum flowrate for channel stability shall be the 100-year, return period flowrate as estimated by WWHM ( $Q_{100}$ ). If an hourly time step is used, multiply the  $Q_{100}$  by 1.6.

d. Below the design water depth install an erosion control blanket, at least 4" of topsoil, and the selected biofiltration mix. Provide vegetation above the water line.

e. This range of Manning's n can be used in the equation;  $b = Qn/1.49y^{(1.67)} S^{(0.5)} - Zy$  with wider bottom width b, and lower depth y, at the same flow. This provides the designer with the option of varying the bottom width of the swale depending on space limitations. Designing at the higher n within this range at the same flow decreases the hydraulic design depth, thus placing the pollutants in closer contact with the vegetation and the soil.

f. For swale widths up to 16 feet the cross-section can be divided with a berm (concrete, plastic, compacted earthfill) using a flow spreader at the inlet (Figure 5 - 21).

### 10.4.1.3 Bypass Guidance

Most biofiltration swales are currently designed to be online facilities. However, an offline design is possible. Swales designed in an offline mode should not engage a bypass until the flowrate exceeds a value determined by multiplying Q, the offline water design flowrate predicted by WWHM, by 3.5. This modified design flow rate is an estimate of the design flow rate determined by using SBUH procedures.

### 10.4.1.4 Sizing Procedure for Biofiltration Swales

#### Preliminary Steps

- P.1. Determine the water quality design flowrate (Q) in 15-minute time steps using WWHM and modified per Section 10.4.1.3.
- P.2. Establish the longitudinal slope of the proposed biofilter.
- P.3. Select an appropriate vegetated cover for the site. Refer to Table 5 - 12 through Table 5 - 14.

### **Design Steps**

- D.1. Select the type of vegetation and depth of flow (based on frequency of mowing and type of vegetation).
- D.2. Select a value of Manning's n (see Table 5 - 9).
- D.3. Select swale shape.
- D.4. Use Manning's equation and first approximations relating hydraulic radius and dimensions for the selected swale shape to obtain a working value of a biofilter bottom and top width dimension:

$$Q = \frac{1.49AR^{0.67}s^{0.5}}{n} \quad (1)$$

Where:

Q = Water quality design flowrate per step P.1 (cfs)

n = Manning's n (dimensionless)

s = Longitudinal slope as a ratio of vertical rise/horizontal run (dimensionless)

A = cross-sectional area (ft<sup>2</sup>)

R = hydraulic radius (ft)

Because the depth of flow in most biofiltration swales is shallow relative to the bottom width, channel side slopes can be ignored in the calculation of bottom width. Use the following equation to estimate the swale bottom width for a trapezoidal swale. For other swale shapes, substitute R and A into Equation 1 to solve for b.

$$b \approx \frac{Qn}{1.49y^{1.67} s^{0.5}} - Zy \quad (2)$$

Where:

b = Bottom width (ft)

Q = Water quality design flowrate per step P.1 (cfs)

n = Manning's n (see Table 5 - 9)

y = Design flow depth (see Table 5 - 9)

s = Longitudinal slope (see Table 5 - 9)

Z = Side slope (for trapezoid select 3)

A minimum 2-foot bottom width is required. If the calculated bottom width is less than 2 feet, increase the width to 2 feet and recalculate the design flow depth y, using equation 3 below.

$$y = \frac{Qn}{1.49s^{0.5}b} \quad (3)$$

Where Q, n, and s are the same as equation 2, but b = 2 feet.

Next, compute the top width T (ft). For a trapezoid.

$$T = b + 2yZ$$

If b for a swale is greater than 10 ft, either investigate how Q can be reduced, divide the flow by installing a low berm, or arbitrarily set b = 10 ft and continue with the analysis. For other swale shapes refer to Figure 5 - 17.

#### D.5. Compute A

$$A_{\text{trapezoid}} = by + Zy^2$$

Where:

A = cross-sectional area (ft<sup>2</sup>)

T = top width of trapezoid or width of a rectangle (ft)

y = depth of flow (ft)

b = bottom width of trapezoid (ft)

Z = side slope

D.6. Compute the flow velocity at design flow rate:

$$V = (Q/A)$$

A = cross-sectional area (ft<sup>2</sup>)

Q = water quality design flow rate per step P.1 (cfs)

If  $V > 1.0$  ft/sec (or  $V > 0.5$  ft/sec for a filter strip), repeat steps D-1 to D-6 until the condition is met. A velocity greater than 1.0 ft/sec was found to flatten grasses, thus reducing filtration. A velocity lower than this maximum value will allow a 9-minute hydraulic residence time criterion in a shorter biofilter. If the value of V suggests that a longer biofilter will be needed than space permits, investigate how Q can be reduced (e.g., use of low impact development BMP's), or increase y and/or T (up to the allowable maximum values) and repeat the analysis.

D.7. Compute the swale length (L, ft)

$$L = Vt \text{ (60 sec/min)}$$

Where: t = hydraulic residence time (min)

V = flow velocity

Use t = 9 minutes for this calculation (use t = 18 minutes for a continuous inflow biofiltration swale). If a biofilter length is greater than the space permits, follow the advice in step 6.

If a length less than 100 feet results from this analysis, increase it to 100 feet, the minimum allowed. In this case, it may be possible to save some space in width and still meet all criteria. This possibility can be checked by computing V in the 100 ft biofilter for t = 9 minutes, recalculating A (if  $V < 1.0$  ft/sec) and recalculating T.

D.8. If there are space constraints, the local government and the project proponent should consider the following solutions (listed in order of preference):

1. Divide the site drainage to flow to multiple biofilters.
2. Use infiltration or other low impact development techniques (Volume 6) to provide lower discharge rates to the biofilter (only if the Site Suitability Criteria in Section 7.6 of this volume are met).
3. Increase vegetation height and design depth of flow (note: the design must ensure that vegetation remains standing during design flow).
4. Reduce the developed surface area to gain space for biofiltration.
5. Increase the longitudinal slope.
6. Increase the side slopes.
7. Nest the biofilter within or around another BMP.



**Stability Check Steps**

The stability check must be performed for the combination of highest expected flow and least vegetation coverage and height. A check is not required for biofiltration swales that are located offline from the primary conveyance/detention system. Maintain the same units as in the biofiltration capacity analysis.

The maximum permissible velocity for erosion prevention ( $V_{max}$ ) is 3 feet per second.

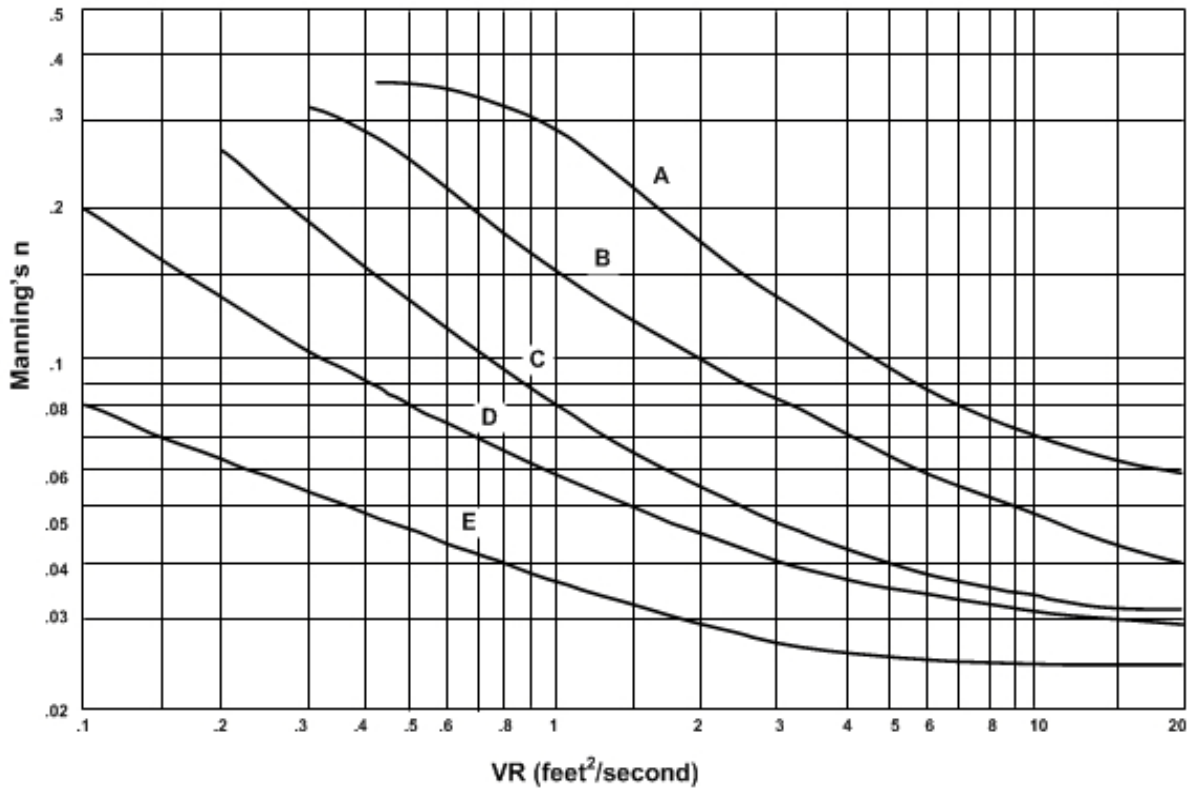
- S.1 Perform the stability check for the 100-year, return frequency flow using 15-minute time steps using WWHM.
- S.2 Estimate the vegetation coverage ("good" or "fair") and height on the first occasion that the biofilter will receive flow, or whenever the coverage and height will be least. Avoid flow introduction during the vegetation establishment period by timing planting.
- S.3 Estimate the degree of retardance from Table 5 - 10. When uncertain, be conservative by selecting a relatively low degree of retardance.

**Table 5 - 10: Stability Check Steps (SC) Guide for Selecting Degree of Retardance<sup>a</sup>**

Coverage	Average Grass Height (inches)	Degree of Retardance
Good	≤ 2	E. Very Low
	2-6	D. Low
	6-10	C. Moderate
	11-24	B. High
	≥ 30	A. Very High
Fair	≤ 2	E. Very Low
	2-6	D. Low
	6-10	D. Low
	11-24	C. Moderate
	≥ 30	B. High

a. See Chow (1959), In addition, Chow recommended selection of retardance C for a grass-legume mixture 6-8 inches high and D for a mixture 4-5 inches high. No retardance recommendations have appeared for emergent wetland species. Therefore, judgment must be used. Since these species generally grow less densely than grasses, using a "fair" coverage would be a reasonable approach

- S.4 Select a trial Manning's n for the high flow condition. The minimum value for poor vegetation cover and low height (possibly, knocked from the vertical by high flow) is 0.033. A good initial choice under these conditions is 0.04.
- S.5 Refer to Figure 5 - 18 to obtain a first approximation for VR.
- S.6 Compute hydraulic radius, R, from VR in Figure 5 - 18 and a  $V_{max}$  in Table 5 - 11.



Note: VR is the product of velocity and hydraulic radius  
 Source: Livingston, et al, 1984

**Figure 5 - 18. The Relationship of Manning's n with VR for Various Degrees of Flow Retardance (A-E)**

**Table 5 - 11: Guide to Selecting Maximum Permissible Swale Velocities for Stability<sup>a</sup>**

Cover	Slope (percent)	Max Velocity - ft/sec (m/sec)	
		Erosion-Resistant Soils	Easily Eroded Soils
Kentucky bluegrass Tall fescue	0-5	6 (1.8)	5 (1.5)
Kentucky bluegrass Ryegrasses Western wheatgrass	5-10	5 (1.5)	4 (1.2)
Grass-legume mixture	0-5	5 (1.5)	4 (1.2)
	5-10	4 (1.2)	3 (0.9)
Red fescue	0-5	3 (0.9)	2.5 (0.8)
Redtop	5-10	Not recommended	Not recommended

<sup>a</sup>.Adapted from Chow (1959), Livingston et al (1984), and Goldman et al (1986)

- S.7 Use Manning's equation to solve for the actual VR.
- S.8 Compare the actual VR from step S.7 and first approximation from step S.5. If they do not agree within 5 percent, repeat steps S.4 to S.8 until acceptable agreement is reached. If  $n < 0.033$  is needed to get agreement, set  $n = 0.033$ , repeat step S.7, and then proceed to step S.9.
- S.9 Compute the actual V for the final design conditions:
- S.10 Check to be sure  $V < V_{\max}$ .
- S.11 Compute the required swale cross-sectional area, A, for stability.
- S.12 Compare the A, computed in step S.11 of the stability analysis, with the A from the biofiltration capacity analysis (step D.5).
- If less area is required for stability than is provided for capacity, the capacity design is acceptable. If not, use A from step S.11 of the stability analysis and recalculate channel dimensions.
- S.13 Calculate the depth of flow at the stability check design flow rate condition for the final dimensions and use A from step S.11.
- S.14 Compare the depth from step S.13 to the depth used in the biofiltration capacity design (Step D.1). Use the larger of the two and add 0.5 ft. of freeboard to obtain the total depth ( $y_t$ ) of the swale. Calculate the top width for the full depth using the appropriate equation.
- S.15 Recalculate the hydraulic radius: (use b from Step D.4 calculated previously for biofiltration capacity, or Step S.12, as appropriate, and  $y_t$  = total depth from Step S.14)
- S.16 Make a final check for capacity based on the stability check design storm (this check will ensure that capacity is adequate if the largest expected event coincides with the greatest retardance). Use Equation 1, a Manning's n selected in step D.2, and the calculated channel dimensions, including freeboard, to compute the flow capacity of the channel under these conditions. Use R from step S.14, above, and  $A = b(y_t) + Z(y_t)^2$  using b from Step D.4, D.8.7, or S.12 as appropriate.
- If the flow capacity is less than the stability check design storm flow rate, increase the channel cross-sectional area as needed for this conveyance. Specify the new channel dimensions.

### **Completion Step**

Review all of the criteria and guidelines for biofilter planning, design, installation, and operation above and specify all of the appropriate features for the application.

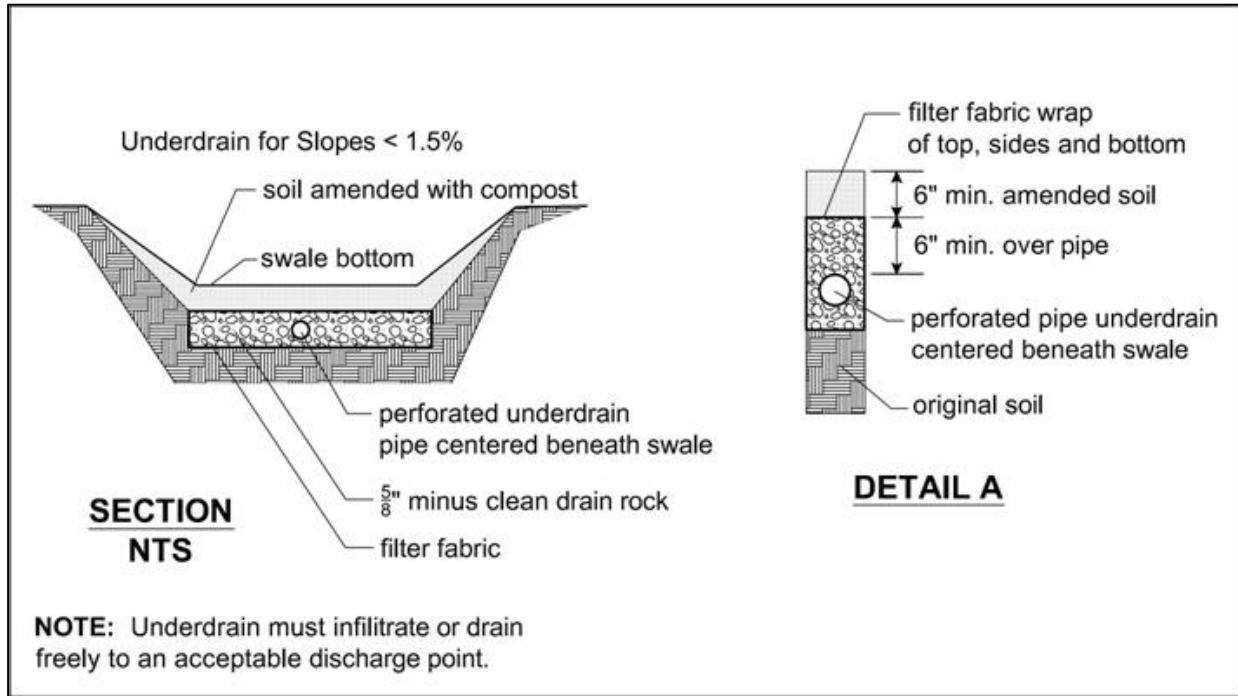


Figure 5 - 19. Biofiltration Swale Underdrain Detail

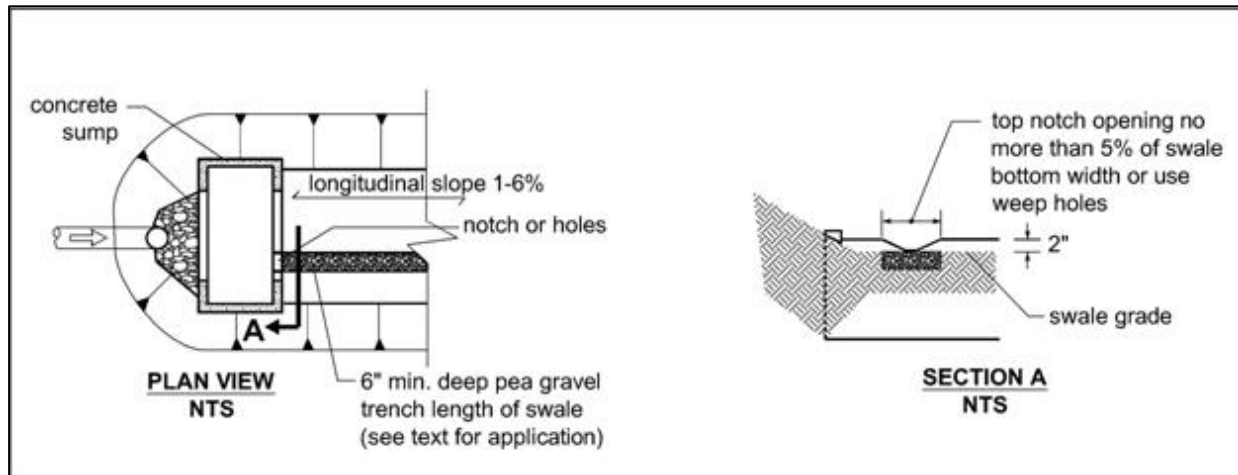


Figure 5 - 20. Biofiltration Swale Low-Flow Drain Detail

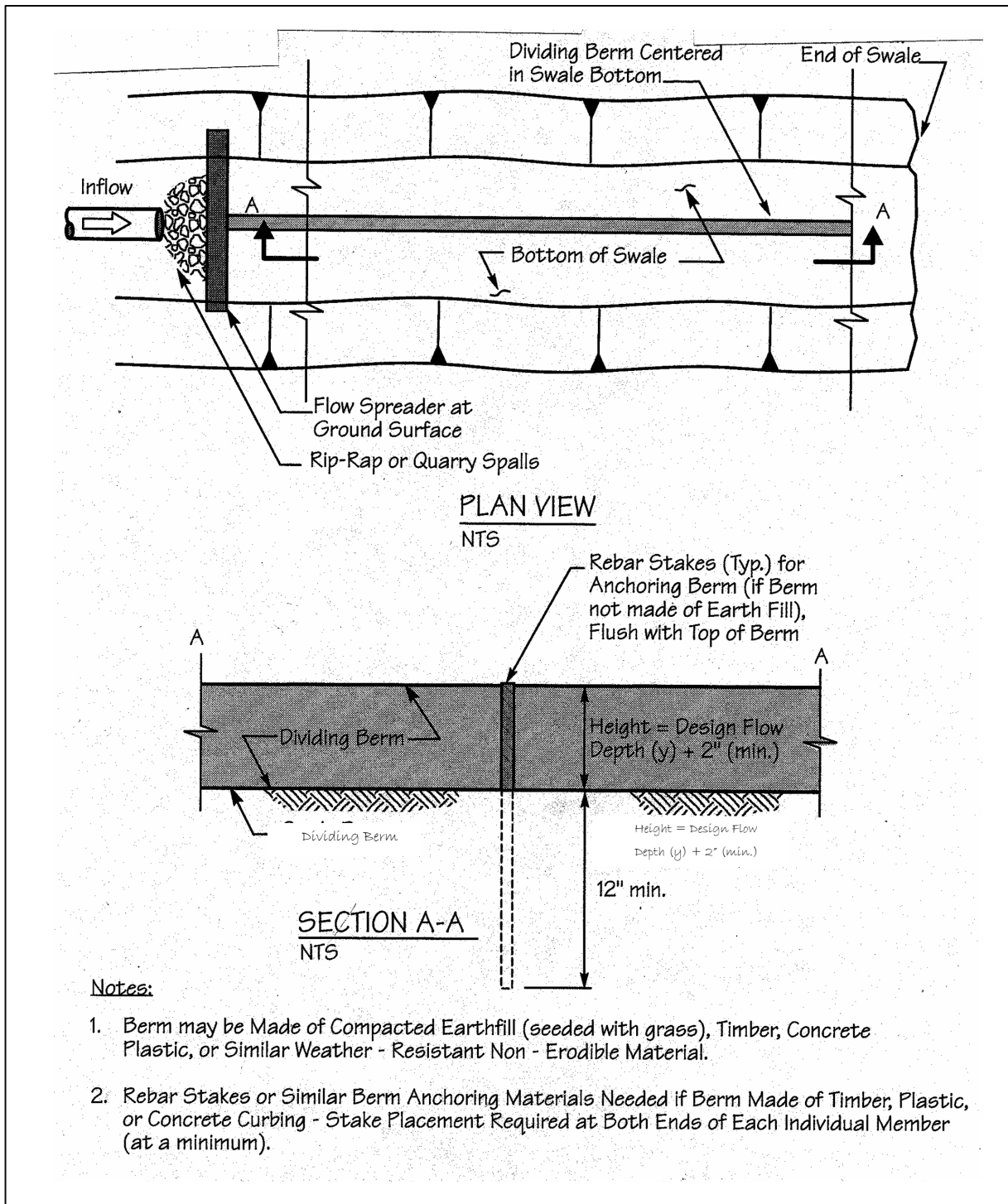


Figure 5 - 21. Swale Dividing Berm

**10.4.1.5 Soil Criteria**

- Use the following list as a guide for choosing appropriate soils for the biofiltration swale. Use at least 8-inches of the following top soil mix:

- Sandy loam 60-90 %
- Clay 0-10 %
- Composted organic matter, 10-30 %  
(excluding animal waste, toxics)
- Compost shall:
  - Meet the definition for “composted material” per WAC 173-350-100 and comply with standards in WAC 173-350-220.
  - Have no visible water or dust during handling.
  - Have soil organic matter content of 40% to 65%.
  - Have a carbon to nitrogen ratio below 25:1. Carbon to nitrogen ratio may be as high as 35:1 for plantings composed entirely of plants native to the Puget Sound Lowlands region.

Compost specifications are also contained in Volume 5, Appendix E.

- Use compost amended soil where practicable.
- Till to at least 8-inch depth.
- For longitudinal slopes of < 2 percent use more sand to obtain more infiltration.
- If groundwater contamination is a concern, seal the bed with clay or a geomembrane liner.

#### **10.4.1.6 Vegetation Criteria**

- See Table 5 - 12 through Table 5 - 14 for recommended grasses, wetland plants, and groundcovers.
- Select fine, turf-forming, water-resistant grasses where vegetative growth and moisture will be adequate for growth.
- Irrigate if moisture is insufficient during dry weather season.
- Use sod with low clay content and where needed to initiate adequate vegetative growth. Preferably sod should be laid to a minimum of one-foot vertical depth above the swale bottom.
- Consider sun/shade conditions for adequate vegetative growth and avoid prolonged shading of any portion not planted with shade tolerant vegetation.
- Stabilize soil areas upslope of the biofilter to prevent erosion.
- Fertilizing a biofilter shall not be allowed.

#### **10.4.1.7 Construction Criteria**

- Do not put swale into operation until exposed soil in contributing drainage area is stabilized.
- Keep erosion and sediment control measures in place until swale vegetation is established.
- Avoid compaction during construction.

Grade biofilters to attain uniform longitudinal and lateral slopes.

**10.4.1.8 Maintenance Criteria**

Per Minimum Requirement #9, an operation and maintenance plan shall be prepared for all stormwater management facilities. See Volume 1, Appendix C, Maintenance Checklist #9 for specific maintenance requirements for biofiltration swales. Maintenance shall be a basic consideration in design and cost-determination of the stormwater management facility.

Any standing water removed during maintenance operation must be disposed of in a City approved manner. See the dewatering requirements in Volume 4 of this manual. Pretreatment may be necessary. Solids must be disposed of in accordance with state and local waste regulations.

Facilities shall be designed and constructed such that the facility can be safely and easily inspected by one person and safely and easily maintained.

**Table 5 - 12: Grass Seed Mixes Suitable for Biofiltration Swale Treatment Areas<sup>a</sup>**

Mix 1		Mix 2	
75-80 percent	tall or meadow fescue	60-70 percent	tall fescue
10-15 percent	seaside/colonial bentgrass	10-15 percent	seaside/colonial bentgrass
5-10 percent	redtop	10-15 percent	meadow foxtail
		6-10 percent	alsike clover
		1-5 percent	marshfield big trefoil
		1-6 percent	redtop

a.All percentages are by weight, based on Briargreen, Inc.

**Table 5 - 13: Groundcovers & Grasses Suitable for the Upper Side Slopes of a Biofiltration Swale in Western Washington**

Groundcovers	
kinnikinnick*	<i>Arctostaphylos uva-ursi</i>
Epimedium	<i>Epimedium grandiflorum</i>
creeping forget-me-not	<i>Omphalodes verna</i>
--	<i>Euonymus lanceolata</i>
yellow-root	<i>Xanthorhiza simplissima</i>
--	<i>Genista</i>
white lawn clover	<i>Trifolium repens</i>
white sweet clover*	<i>Melilotus alba</i>
-----	<i>Rubus calycinoides</i>
Grasses (drought-tolerant, minimum mowing)	
dwarf tall fescues	<i>Festuca</i> spp. (e.g., Many Mustang, Silverado)
hard fescue	<i>Festuca ovina duriuscula</i> (e.g., Reliant, Aurora)
tufted fescue	<i>Festuca amethystina</i>
buffalo grass	<i>Buchloe dactyloides</i>
red fescue*	<i>Festuca rubra</i>
tall fescue grass*	<i>Festuca arundinacea</i>
blue oatgrass	<i>Helictotrichon sempervirens</i>

\* Good choices for swales with significant periods of flow, such as those downstream of a detention facility.



**Table 5 - 14: Recommended Plants for Wet Biofiltration Swale**

Common Name	Scientific Name	Spacing (on center)
Shortawn foxtail	<i>Alopecurus aequalis</i>	seed
Water foxtail	<i>Alopecurus geniculatus</i>	seed
Spike rush	<i>Eleocharis spp.</i>	4 inches
Slough sedge*	<i>Carex obnupta</i>	6 inches or seed
Sawbeak sedge	<i>Carex stipata</i>	6 inches
Sedge	<i>Carex spp.</i>	6 inches
Western mannagrass	<i>Glyceria occidentalis</i>	seed
Velvetgrass	<i>Holcus mollis</i>	seed
Slender rush	<i>Juncus tenuis</i>	6 inches
Water parsley*	<i>Oenanthe sarmentosa</i>	6 inches
Hardstem bulrush	<i>Scirpus acutus</i>	6 inches
Small-fruited bulrush	<i>Scirpus microcarpus</i>	12 inches

\* Good choices for swales with significant periods of flow, such as those downstream of a detention facility. Cattail (*Typha latifolia*) is not appropriate for most wet swales because of its very dense and clumping growth habit which prevents water from filtering through the clump.

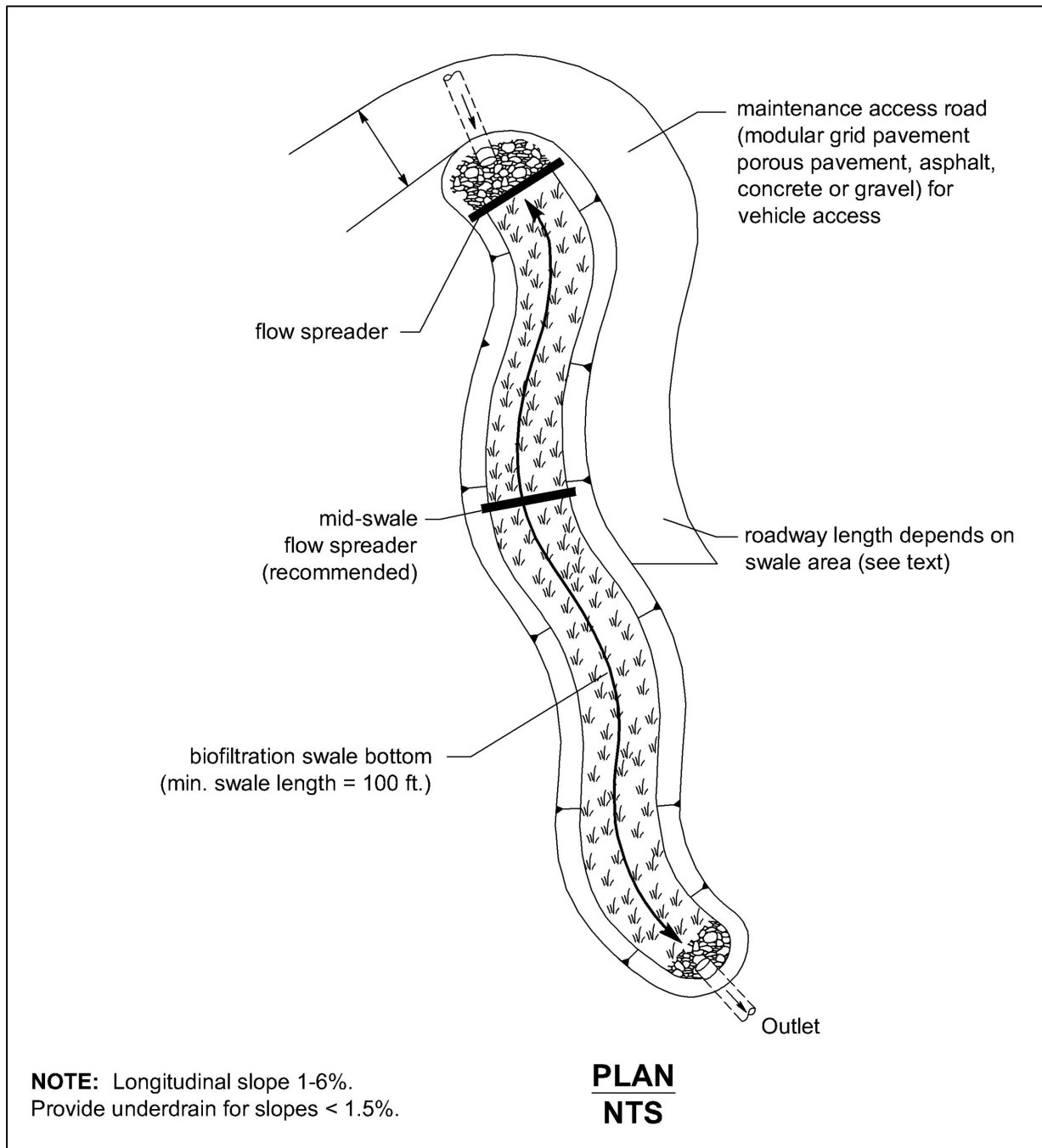


Figure 5 - 22. Biofiltration Swale Access Features

## 10.4.2 BMP T1020 Wet Biofiltration Swale

### 10.4.2.1 Description

A *wet biofiltration swale* is a variation of a basic biofiltration swale for use where the longitudinal slope is slight, water tables are high, or continuous low base flow is likely to result in saturated soil conditions. Where saturation exceeds about 2 weeks, typical grasses will die. Thus, vegetation specifically adapted to saturated soil conditions is needed. Different vegetation in turn requires modification of several of the design parameters for the basic biofiltration swale.

### 10.4.2.2 Performance Objectives

To provide basic water quality treatment.

### 10.4.2.3 Applications/Limitations

Wet biofiltration swales are applied where a basic biofiltration swale is desired but not allowed or advisable because one or more of the following conditions exist:

- The swale is located on glacial till soils and is downstream of a detention pond providing flow control.
- Saturated soil conditions are likely because of seeps or base flows on the site.
- Longitudinal slopes shall be less than 2 percent.

### 10.4.2.4 Design Criteria

Use the same sizing and criteria as for basic biofiltration swales except for the following:

1. Adjust for extended wet season flow.
  - If the swale will be downstream of a detention pond or vault providing flow control, multiply the treatment area (bottom width times length) of the swale by 2, and readjust the swale length, if desired. Maintain a 5:1 length to width ratio.
2. Swale geometry.
  - The bottom width may be increased to 25 feet maximum, but a length-to-width ratio of 5:1 must be provided. No longitudinal dividing berm is needed.  
The minimum swale length is 100 feet.
  - If longitudinal slopes are greater than 2 percent, the wet swale must be stepped so that the slope within the stepped sections averages 2 percent. Steps may be made of retaining walls, log check dams, or short riprap sections. **No underdrain or low-flow drain is required.**
3. High-flow bypass
  - A high-flow bypass (i.e., an offline design) is required for flows greater than the offline water quality design flow that has been increased by 3.5. The bypass may be an open channel parallel to the wet biofiltration swale.
4. Water Depth and Base Flow
  - Design water depth shall be 4 inches for all wetland vegetation selections.
  - No underdrains or low-flow drains are required.
5. Flow Velocity, Energy Dissipation, and Flow Spreading

- No flow spreader is required.

#### 6. Access

- Access is only required to the inflow and outflow of the swale. Access along the swale is not required.
- Wheel strips may not be used for access.

#### 7. Planting Requirements

- A list of acceptable plants and recommended spacing is shown in Table 5 - 14.
- A wetland seed mix may be applied by hydroseeding, but if coverage is poor, planting of rootstock or nursery stock is required. Poor coverage is considered to be more than 30 percent bare area through the upper 2/3 of the swale after four weeks.

#### 8. Maintenance Considerations

- See Volume 1, Appendix C, Checklist #10 for specific maintenance requirements for wet biofiltration swales.

### **10.4.3 BMP T1030 Continuous Inflow Biofiltration Swale**

#### **10.4.3.1 Description**

In situations where water enters a biofiltration swale continuously along the side slope rather than discretely at the head, a different design approach—the continuous inflow biofiltration swale—is needed. The basic swale design is modified by increasing swale length to achieve an equivalent average residence time.

#### **10.4.3.2 Applications**

A continuous inflow biofiltration swale is to be used when inflows are not concentrated, such as locations along the shoulder of a road without curbs. This design may also be used where frequent, small point flows enter a swale, such as through curb inlet ports spaced at intervals along a road, or from a parking lot with frequent curb cuts. In general, no inlet port shall carry more than about 10 percent of the flow.

A continuous inflow swale is not appropriate for a situation in which significant lateral flows enter a swale at some point downstream from the head of the swale. In this situation, the swale width and length must be recalculated from the point of confluence to the discharge point in order to provide adequate treatment for the increased flows.

#### **10.4.3.3 Design Criteria**

Same as specified for basic biofiltration swale except for the following:

- The design flow for continuous inflow swales must include runoff from the pervious side slopes draining to the swale along the entire swale length. Therefore, they must be online facilities.
- If only a single design flow is used, the flow rate at the outlet should be used. The goal is to achieve an average residence time through the swale of 9 minutes as calculated using the online water quality design flow rate multiplied by the ratio, K (see footnotes in Table 5 - 9). Assuming an even distribution of inflow into the side of the swale double the hydraulic residence time to a minimum of 18 minutes.
- Interior side slopes above the water quality design treatment elevation shall be planted in grass. A typical lawn seed mix or the biofiltration seed mixes are acceptable. Landscape plants or groundcovers other than grass may not be used anywhere between the runoff inflow elevation and the bottom of the swale.

## **10.4.4 BMP T1040 Basic Filter Strip**

### **10.4.4.1 Description**

A basic filter strip is flat with no side slopes (Figure 5 - 23). Untreated stormwater is distributed as sheet flow across the inlet width of a biofilter strip.

### **10.4.4.2 Applications/Limitations**

The basic filter strip is typically used online and adjacent and parallel to a paved area such as parking lots, driveways, and roadways.

### **10.4.4.3 Design Criteria for Filter strips**

- Use the Design Criteria specified in Table 5 - 15.
- Filter strips shall only receive sheet flow.
- Use curb cuts  $\geq$  12-inch wide and 1-inch above the filter strip inlet.

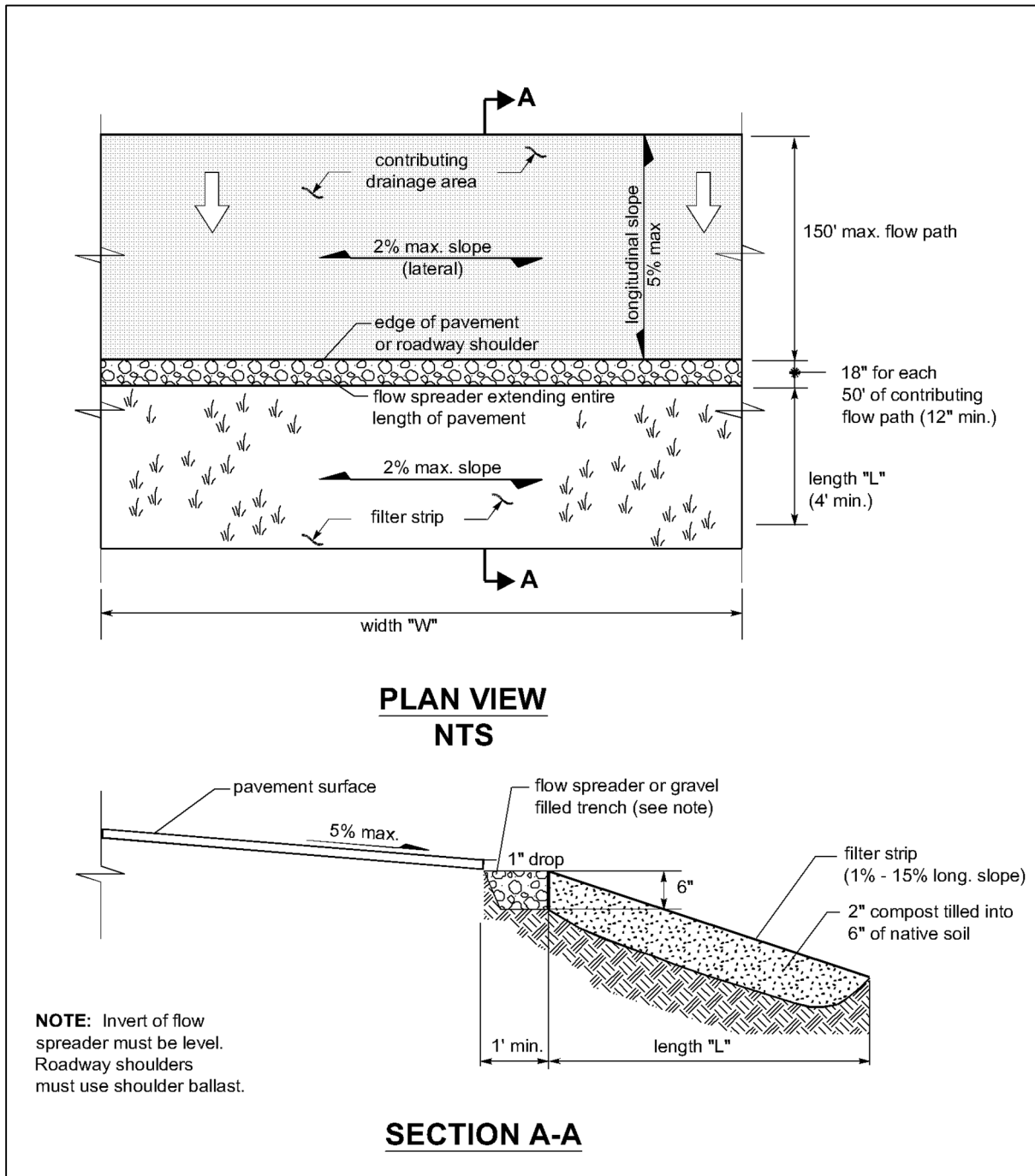


Figure 5 - 23. Typical Filter Strip

**Table 5 - 15: Sizing Criteria**

Design Parameter	BMP T1040 - Filter Strip
Longitudinal Slope <sup>a</sup>	0.01 - 0.33
Maximum velocity <sup>b</sup>	0.5 ft / sec @ K multiplied by the WQ design flow rate
Maximum velocity for channel stability <sup>c</sup>	---
Maximum water depth <sup>d</sup>	1-inch max.
Manning coefficient <sup>e</sup>	0.35
Bed width (bottom) <sup>f</sup>	---
Freeboard height	---
Minimum hydraulic residence time at K multiplied by Water Quality Design Flow Rate	9 minutes
Minimum length	Sufficient to achieve hydraulic residence time in the filter strip
Maximum sideslope	Inlet edge $\geq$ 1" lower than contributing paved area
Max. tributary drainage flowpath	150 feet
Max. longitudinal slope of contributing area	0.05 (steeper than 0.05 need upslope flow spreading and energy dissipation)
Max lateral slope of contributing area	0.02 (at the edge of the strip inlet)

- a. For swales, if the slope is less than 1.5% install an underdrain using a perforated pipe, or equivalent. Amend the soil if necessary to allow effective percolation of water to the underdrain. Install the low-flow drain 6" deep in the soil. Slopes greater than 2.5% need check dams (riprap) at vertical drops of 12-15 inches. Underdrains can be made of 6 inch Schedule 40 PVC perforated pipe or equivalent with 6" of drain gravel on the pipe. The gravel and pipe must be enclosed by geotextile fabric (see Figure 5 - 19 and Figure 5 - 20).
- b. K=A ratio of the peak 10-minute flow predicted by SBUH to the water quality design flow rate estimated using the WWHM. The value of K for offline systems is 3.5, and for online systems is 2.0 in the City of Tacoma.
- c. Maximum flowrate for channel stability shall be the 100-year, return period flowrate as estimated by WWHM ( $Q_{100}$ ). If an hourly time step is used, multiply the  $Q_{100}$  by 1.6.
- d. Below the design water depth install an erosion control blanket, at least 4" of topsoil, and the selected biofiltration mix. Provide vegetation above the water line.
- e. This range of Manning's n can be used in the equation;  $b = Qn/1.49y^{(1.67)} S^{(0.5)} - Zy$  with wider bottom width b, and lower depth y, at the same flow. This provides the designer with the option of varying the bottom width of the swale depending on space limitations. Designing at the higher n within this range at the same flow decreases the hydraulic design depth, thus placing the pollutants in closer contact with the vegetation and the soil.
- f. For swale widths up to 16 feet the cross-section can be divided with a berm (concrete, plastic, compacted earthfill) using a flow spreader at the inlet (Figure 5 - 21).

#### 10.4.4.4 Sizing Procedure

Use the design parameters in Table 5 - 15 above in the equations below as applicable.

1. Calculate the design flow depth using Manning's equation as follows:

$$KQ = (1.49A R^{0.67} s^{0.5})/n$$

Substituting for AR:



$$KQ = (1.49Ty^{1.67} s^{0.5})/n$$

Where:

$$Ty = A_{\text{rectangle, ft}}^2$$

$y$  =  $R_{\text{rectangle}}$ , design depth of flow, ft. (1 inch maximum)

$Q$  = Water Quality design flowrate estimated by WWHM, ft<sup>3</sup>/sec

$K$  = A ratio of the peak 10-minute flow predicted by SBUH to the water quality design flow rate estimated using the WWHM. The value of  $K$  for offline systems is 3.5 and for online systems is 2.0.<sup>1</sup>

$n$  = Manning's roughness coefficient

$s$  = Longitudinal slope of filter strip parallel to direction of flow

$T$  = Width of filter strip perpendicular to the direction of flow, ft.

$A$  = Filter strip inlet cross-sectional flow area (rectangular), ft<sup>2</sup>

$R$  = hydraulic radius, ft.

Rearranging for  $y$ :

$$y = [KQn/1.49Ts^{0.5}]^{0.6}$$

$y$  must not exceed 1 inch

2. Calculate the design flow velocity  $V$ , ft./sec., through the filter strip:

$$V = KQ/Ty$$

$V$  must not exceed 0.5 ft./sec

3. Calculate required length, ft., of the filter strip at the minimum hydraulic residence time,  $t$ , of 9 minutes:

$$L = tV = 540 V$$

#### 10.4.4.5 Maintenance

Per Minimum Requirement #9, an operation and maintenance plan shall be prepared for all stormwater management facilities. See Volume 1, Appendix C, Maintenance Checklist #11 for specific maintenance requirements for filter strips. Maintenance shall be a basic consideration in design and cost-determination of the stormwater management facility.

Any standing water removed during maintenance operation must be disposed of in a City approved manner. See the dewatering requirements in Volume 4 of this manual. Pretreatment may be necessary. Solids must be disposed of in accordance with state and local waste regulations.

Facilities shall be designed and constructed such that the facility can be safely and easily inspected by one person and safely and easily maintained.

---

1. As in swale design, an adjustment factor of  $K$  accounts for the differential between the Water Quality design flow rate calculated using WWHM and the SBUH design flow.

## **10.4.5 BMP T1050: Compost-Amended Vegetated Filter Strip (CAVFS)**

### **10.4.5.1 Description**

CAVFS are a variation of the basic filter strip that includes soil amendments. The soil amendments improve infiltration characteristics, increase surface roughness, and improve plant sustainability.

### **10.4.5.2 Applications**

CAVFS can be used for basic and enhanced water quality treatment.

### **10.4.5.3 Design Criteria**

See Figure 5 - 24.

Filter strips shall only receive sheet flow.

Use curb cuts  $\geq$  12 inch wide and 1 inch above the filter strip inlet.

The CAVFS shall treat 91% of the influent runoff file through the soil profile using WWHM. WWHM 2012 contains a CAVFS element that shall be used for design.

The following apply to the required compost-amended soil section:

- The soil mix shall:
  - Have an initial saturated hydraulic conductivity less than 12 inches/hour.
  - Have a minimum long-term hydraulic conductivity less than 1.0 inches/hour per ASTM D2434 (Standard Test Method for Permeability of Granular Soils) at 85% compaction per ASTM D1557 (Standard Test Method for Laboratory Compaction Characteristics of Soil Using Modified Effort).
  - Have a minimum organic content of 5% by dry weight per ASTM Designation D2974 (Standard Test Method for Moisture, Ash, and Organic Matter of Peat and Other Organic Soils).
  - Have a clay content less than 5%.
  - Have a pH between 5.5 and 7.0.
  - Be uniform and free of stones, stumps, roots, or material larger than 2 inches.
- The compost component shall:
  - Meet the definition of “composted material” in WAC 173-350-100 and comply with testing parameters and other standards in WAC 173-350-220.
  - Be produced at a composting facility that is permitted by the jurisdictional health authority. Permitted compost facilities in Washington are included on a list available at: [www.ecy.wa.gov/programs/swfa/organics](http://www.ecy.wa.gov/programs/swfa/organics)
  - The compost product must originate from a feedstock that contains a minimum of 65% by volume recycled plant waste comprised of “yard debris,” “crop residues,” and “bulking agents”. The remainder of the feedstock may contain a maximum of 35% by volume “post-consumer food waste”. Biosolids are not allowed. Terms are defined in WAC 173-350-100.
  - Stable (low oxygen use and CO<sub>2</sub> generation) and mature (capable of supporting plant growth) by tests shown below. This is critical to plant success in a bioretention soil mix.

- Moisture content range: no visible free water or dust produced when handling the material.
- Tested in accordance with U.S. Composting Council “Test Method for the Examination of Compost and Composting” (TMECC), as established in the Composting Council’s “Seal of Testing Assurance” (STA) program. Most Washington compost facilities now use these tests.
- Be fine compost meeting the following size gradation (by dry weight) when tested in accordance with TMECC test method 02.02-B, “Sample Sieving for Aggregate Size Classification.”

Sieve Size	Minimum Percent Passing
2”	100
1”	99
5/8”	90
1/4”	75

- pH between 6.0 and 8.5 (TMECC 04.11-A).
- “Physical contaminants” (as defined in WAC 173-350-100) content less than 1% by weight (TMECC 03.08-A) total, not to exceed 0.25 percent film plastic by dry weight.
- Minimum organic matter content of 40% (TMECC 05.07-A “Loss on Ignition”)
- Soluble salt content less than 4.0 dS/m (mmhos/cm) (TMECC 04.10-A “Electrical Conductivity, 1.5 Slurry Method, Mass Basis”)
- Maturity indicators from a cucumber bioassay (TMEC 05.05-A “Seedling Emergence and Relative Growth”) must be greater than 80% for both emergence and vigor
- Stability of 7 mg CO<sub>2</sub>-C/g OM/day or below (TMECC 05.08-B “Carbon Dioxide Evolution Rate”)
- Carbon to nitrogen ratio (TMECC 05.02A “Carbon to Nitrogen Ratio” which uses 04.01 “Organic Carbon” and 04.02D “Total Nitrogen by Oxidation”) of less than 25:1. The C:N ratio may be up to 35:1 for planting composed entirely of Puget Sound Lowland native species and up to 40:1 for coarse compost to be used as a surface mulch (not in a soil mix).

Compost specifications are also contained in Volume 5, Appendix E.

- The soil component shall be loamy sand (USDA Soil Textural Classification).
- The final soil mixture should be tested prior to installation for fertility, micronutrient analysis and organic material content.
- Choose one of the following methods in order to obtain a soil mix that meets the criteria above:
  - Presumptive Approach: Place and rototill 1.75 inches of composted material into 6.25 inches of soil to achieve a total amended depth of 9.5 inches, for a settled depth of 8 inches. Water or roll compact soil to 85% maximum. Plant the filter strip.
  - Custom Approach: Place and rototill the calculated amount of composted material into a depth of soil needed to achieve 8 inches of settled soil at 5% organic content. Water or roll to compact soil to 85% maximum. Plant the filter strip.

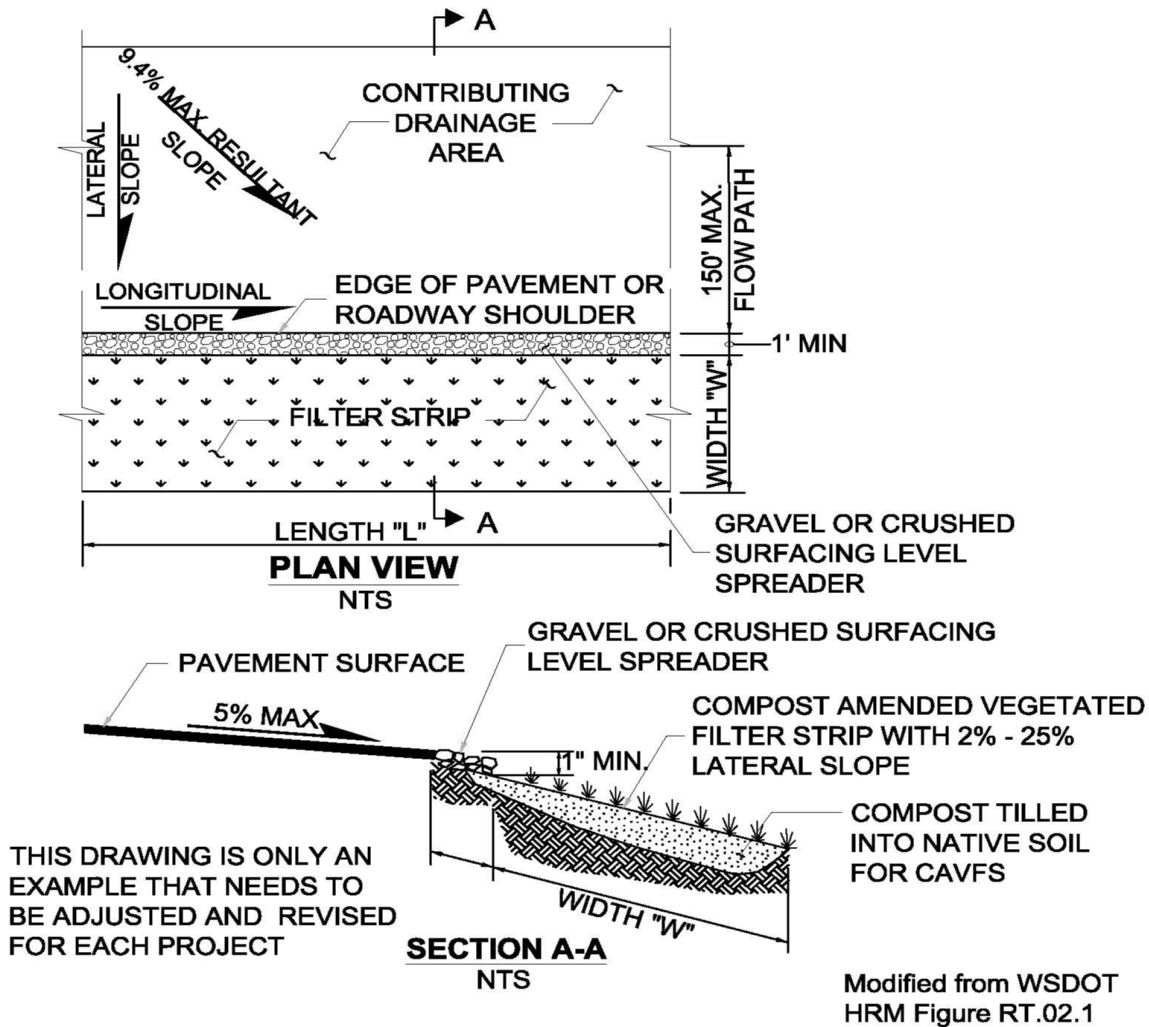
Generally, the required soil mix can be achieved with 60-65% loamy sand mixed with 25-30% compost or a 30% sandy loam, 30% coarse sand, 30% compost blend.

**10.4.5.4 Maintenance**

Per Minimum Requirement #9, an operation and maintenance plan shall be prepared for all stormwater management facilities. See Volume 1, Appendix C, Maintenance Checklist #11 for specific maintenance requirements for filter strips. Maintenance shall be a basic consideration in design and cost-determination of the stormwater management facility.

Any standing water removed during maintenance operation must be disposed of in a City approved manner. See the dewatering requirement in Volume 4 of this manual. Pretreatment may be necessary. Solids must be disposed of in accordance with state and local waste regulations.

Facilities shall be designed and constructed such that the facility can be safely and easily inspected by one person safely and easily maintained.



*Figure 5 - 24. Compost Amended Vegetated Filter Strip (CAVFS)*

**This Page Intentionally Left Blank**

# Chapter 11 Wetpool Facilities

## 11.1 Purpose

This Chapter presents the methods, criteria, and details for analysis and design of wetponds, wetvaults, and stormwater wetlands. These facilities have as a common element, a permanent pool of water - the wetpool. Each of the wetpool facilities can be combined with detention storage in a combined facility.

## 11.2 Best Management Practices

The following wetpool facility BMPs are discussed in this chapter:

- BMP T1110 Wetponds - Basic and Large
- BMP T1120 Wetvaults
- BMP T1130 Stormwater Wetlands
- BMP T1140 Combined Detention and Wetpool Facilities

The specific BMPs that are selected should be based on the Treatment Facility Menus discussed in Chapter 2.

### 11.2.1 BMP T1110 Wetponds - Basic and Large

#### 11.2.1.1 Description

A wetpond is a constructed stormwater pond that retains a permanent pool of water ("wetpool") at least during the wet season. The volume of the wetpool is related to the effectiveness of the pond in settling particulate pollutants. As an option, a shallow marsh area can be created within the permanent pool volume to provide additional treatment for nutrient removal. Flow control can be provided in the "live storage" area above the permanent pool. Figure 5 - 25 and Figure 5 - 26 illustrate a typical wetpond.

#### 11.2.1.2 Design Criteria

For a basic wetpond, the wetpool volume provided shall be equal to or greater than the total volume of runoff from the water quality design storm, which is the 6-month, 24-hour storm event.

Alternatively, the water quality design storm volume shall be equal to the simulated daily volume indicated by WWHM that represents the upper limit of the range of daily volumes that accounts for 91% of the entire runoff volume over a multi-decade period of record.

A large wetpond requires a wetpool volume at least 1.5 times larger than the total volume of runoff from the 6-month, 24-hour storm event.

Design features that encourage plug flow and avoid dead zones are:

- Dissipating energy at the inlet.
- Providing a large length-to-width ratio.
- Providing a broad surface for water exchange using a berm designed as a broad-crested weir to divide the wetpond into two cells rather than a constricted area such as a pipe.
- Maximizing the flowpath between inlet and outlet, including the vertical path, also enhances treatment by increasing residence time.

General wetpond design criteria and concepts are shown in Figure 5 - 25 and Figure 5 - 26.

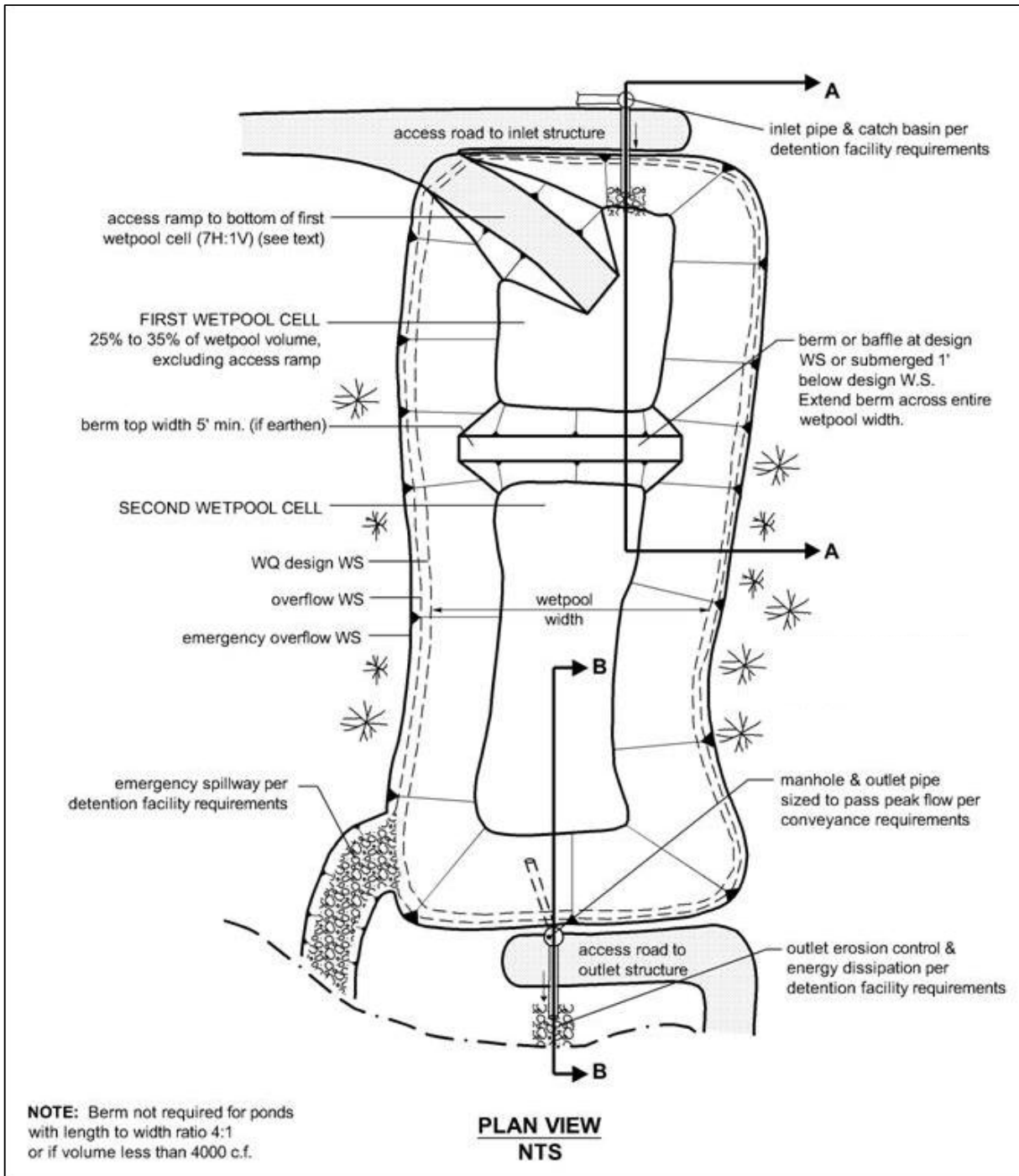


Figure 5 - 25. Wetpond (top view)

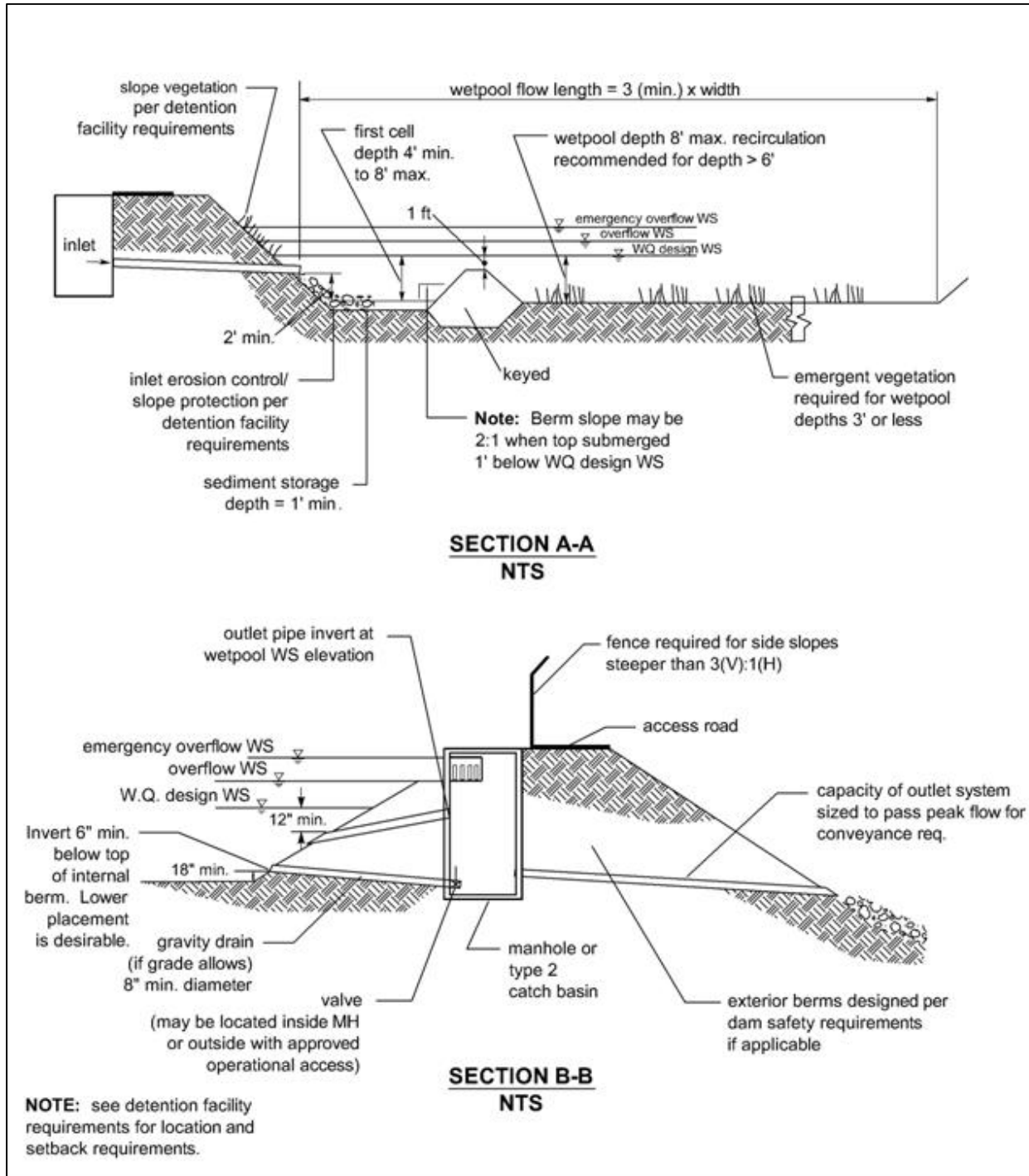


Figure 5 - 26. Wetpond (side view)



### 11.2.1.3 Sizing Procedure

Procedures for determining a wetpond's dimensions and volume are outlined below.

1. Identify required wetpool volume using the SCS (now known as NRCS) curve number equations. A basic wetpond requires a volume equal to or greater than the total volume of runoff from the 6-month, 24-hour storm event, or, alternatively, the water quality design volume using WWHM. A large wetpond requires a volume at least 1.5 times the total volume of runoff from the 6-month, 24-hour storm event or 1.5 times the water quality design volume using WWHM.
2. Determine wetpool dimensions. Determine the wetpool dimensions satisfying the design criteria outlined below and illustrated in Figure 5 - 25 and Figure 5 - 26. A simple way to check the volume of each wetpool cell is to use the following equation:

$$V = \frac{h(A_1 + A_2)}{2}$$

where:  $V$  = wetpool volume (ft<sup>3</sup>)

$h$  = wetpool average depth (ft)

$A_1$  = water quality design surface area of wetpool (sf)

$A_2$  = bottom area of wetpool (sf)

3. Design pond outlet pipe and determine primary overflow water surface. The pond outlet pipe shall be placed on a reverse grade from the pond's wetpool to the outlet structure. Provide documentation on how the outlet pipe was sized. Volume 3 contains guidance for conveyance system design. Pipe sizing shall be based on backwater effects.
4. Determine wetpond dimensions.

### 11.2.1.4 Wetpool Geometry

- Divide the wetpool into two cells separated by a baffle or berm. The first cell shall contain between 25 to 35 percent of the total wetpool volume. The baffle or berm volume shall not count as part of the total wetpool volume.
- Provide sediment storage in the first cell. The sediment storage shall have a minimum depth of 1-foot. Install a fixed sediment depth monitor in the first cell to gauge sediment accumulation unless an alternative gauging method is proposed.
- The minimum depth of the first cell shall be 4 feet, exclusive of sediment storage requirements. The depth of the first cell may be greater than the depth of the second cell.
- The maximum depth of each cell shall not exceed 8 feet (exclusive of sediment storage in the first cell). Plant pool depths of 3 feet or shallower (second cell) with emergent wetland vegetation (see planting requirements).
- Place inlets and outlets to maximize the flowpath through the facility. The ratio of flowpath length to width from the inlet to the outlet shall be at least 3:1. The **flowpath length** is defined as the distance from the inlet to the outlet, as measured at mid-depth. The **width** at mid-depth can be found as follows: width = (average top width + average bottom width)/2.
- Wetponds with wetpool volumes less than or equal to 4,000 cubic feet may be single celled (i.e., no baffle or berm is required). However, it is especially important in this case that the flowpath length be maximized. The ratio of flowpath length to width shall be at least 4:1 in single celled wetponds, but should preferably be 5:1.

- All inlets shall enter the first cell. For multiple inlets, the length-to-width ratio shall be based on the average flowpath length for all inlets.
- Line the first cell in accordance with the liner requirements contained in Chapter 4.

#### **11.2.1.5 Berms, Baffles, and Slopes**

- A berm or baffle shall extend across the full width of the wetpool, and tie into the wetpond side slopes. If the berm embankments are greater than 4 feet in height, the berm must be constructed by excavating a key with dimensions equal to 50 percent of the embankment cross-sectional height and width. This requirement may be waived if recommended by a geotechnical engineer for specific site conditions. The geotechnical analysis shall address situations in which one of the two cells is empty while the other remains full of water.
- The top of the berm may extend to the WQ design water surface or be 1-foot below the WQ design water surface. If at the WQ design water surface, berm side slopes shall be 3H:1V. Berm side slopes may be steeper (up to 2H:1V) if the berm is submerged 1-foot.
- If good vegetation cover is not established on the berm, erosion control measures shall be used to prevent erosion of the berm back-slope when the pond is initially filled.
- The interior berm or baffle may be a retaining wall provided that the design is prepared and stamped by a licensed civil engineer. If a baffle or retaining wall is used, it shall be submerged one foot below the design water surface to discourage access by pedestrians.
- Side slopes shall not exceed a slope of 3H:1V. Moderately undulating slopes are acceptable and can provide a more natural setting for the facility. In general, gentle side slopes improve the aesthetic attributes of the facility and enhance safety.

#### **11.2.1.6 Embankments**

Embankments that impound water must comply with the Washington State Dam Safety Regulations (Chapter 173-175 WAC). If the impoundment has a storage capacity (including both water and sediment storage volumes) greater than 10 acre-feet (435,600 cubic feet or 3.26 million gallons) above natural ground level, then dam safety design and review are required by the Department of Ecology. Contact Ecology for information about this regulation.

#### **11.2.1.7 Inlet and Outlet**

See Figure 5 - 25 and Figure 5 - 26 for details on the following requirements:

- Submerge the inlet to the wetpond with the inlet pipe invert a minimum of two feet from the pond bottom (not including sediment storage). The top of the inlet pipe shall be submerged at least 1-foot, if possible.
- Provide an outlet structure. Either a Type 2 catch basin with a grated opening (“jail house window”) or a manhole with a cone grate (“birdcage”) may be used (see Figure 3 - 17 for an illustration).
- The pond outlet pipe (as opposed to the manhole or type 2 catch basin outlet pipe) shall be back-sloped or have a down-turned elbow, and extend 1 foot below the WQ design water surface.
- Size the pond outlet pipe, at a minimum, to pass the online WQ design flow. The highest invert of the outlet pipe sets the WQ design water surface elevation.
- The overflow criteria for single-purpose (treatment only, not combined with flow control) wetponds are as follows:

- The requirement for primary overflow is satisfied by either the grated inlet to the outlet structure or by a birdcage above the pond outlet structure.
- The bottom of the grate opening in the outlet structure shall be set at or above the height needed to pass the WQ design flow through the pond outlet pipe. The grate invert elevation sets the overflow water surface elevation.
- The grated opening and downstream conveyance shall be sized to pass the 100-year design flow. The capacity of the outlet system shall be sized to pass the peak flow for the conveyance requirements.
- Provide an emergency spillway and design it according to the requirements for detention ponds (see Volume 3, Section 7.1.3).
- The City may require a bypass/shutoff valve to enable the pond to be taken offline for maintenance purposes.
- A gravity drain for maintenance is recommended if grade allows.
  - The drain invert shall be at least 6 inches below the top elevation of the dividing berm or baffle. Deeper drains are encouraged where feasible, but must be no deeper than 18 inches above the pond bottom.
  - The drain shall be at least 8 inches (minimum) diameter and shall be controlled by a valve. Use of a shear gate is allowed only at the inlet end of a pipe located within an approved structure.
  - Provide operational access to the valve to the finished ground surface.
  - The valve location shall be accessible and well marked with 1-foot of paving placed around the box. It must also be protected from damage and unauthorized operation.
  - A valve box is allowed to a maximum depth of 5 feet without an access manhole. If over 5 feet deep, an access manhole or vault is required.
- All metal parts shall be corrosion-resistant. Do not use galvanized materials.

#### **11.2.1.8 Access and Setbacks**

- All facilities shall be a minimum of 20 feet from any structure, property line, and any vegetative buffer required by the local government, and 100 feet from any septic tank/drainfield.
- All facilities shall be a minimum of 50 feet from any slope greater than 15 percent. A geotechnical report must address the potential impact of a wetpond on a slope steeper than 15% or if closer than 50 feet.
- Access is the same as for detention ponds (Volume 3).
- If the dividing berm is also used for access, it should be built to sustain loads of up to 80,000 pounds.

#### **11.2.1.9 Planting Requirements**

Planting requirements for detention ponds also apply to wetponds.

- Large wetponds intended for phosphorus control shall not be planted within the cells, as the plants will release phosphorus in the winter when they die off. The bottom and side slopes shall be stabilized to prevent erosion.
- If the second cell of a basic wetpond is 3 feet deep or shallower, the bottom area shall be planted with emergent wetland vegetation. See Table 5 - 16 for recommended emergent

wetland plant species for wetponds. The recommendations in Table 5 - 16 are for all of western Washington. Local knowledge should be used to tailor this information to Tacoma as appropriate.

- Cattails (*Typha latifolia*) shall not be used because they tend to crowd out other species.
- If the wetpond discharges to a phosphorus-sensitive lake or wetland, shrubs that form a dense cover should be planted on slopes above the WQ design water surface on at least three sides. Native vegetation species shall be used in all cases.
- Provide a planting plan that shows mature plant coverage and species type.

#### **11.2.1.10 Recommended Design Features**

The following features should be incorporated into the wetpond design where site conditions allow:

- The method of construction of soil/landscape systems can cause natural selection of specific plant species. Consult a soil restoration or wetland soil scientist for site-specific recommendations. The soil formulation will impact the plant species that will flourish or suffer on the site, and the formulation should be such that it encourages desired species and discourages undesired species.
- For wetpool depths in excess of 6 feet, it is recommended that some form of recirculation be provided in the summer, such as a fountain or aerator, to prevent stagnation and low dissolved oxygen conditions.
- A flow length-to-width ratio greater than the 3:1 minimum is desirable. If the ratio is 4:1 or greater, then the dividing berm is not required, and the pond may consist of one cell rather than two. A one-cell pond must provide at least 6-inches of sediment storage depth.
- A tear-drop shape, with the inlet at the narrow end, rather than a rectangular pond is preferred since it minimizes dead zones caused by corners.
- A small amount of base flow is desirable to maintain circulation and reduce the potential for low oxygen conditions during late summer.
- Evergreen or columnar deciduous trees along the west and south sides of ponds are recommended to reduce thermal heating, except that no trees or shrubs may be planted on berms meeting the criteria of dams regulated for safety. In addition to shade, trees and shrubs also discourage waterfowl use and the phosphorus enrichment problems they cause. Trees should be set back so that the branches will not extend over the pond.
- The number of inlets to the facility should be limited; ideally there should be only one inlet. The flowpath length should be maximized from inlet to outlet for all inlets to the facility.
- The access and maintenance road could be extended along the full length of the wetpond and could double as play courts or picnic areas. Placing finely ground bark or other natural material over the road surface would render it more pedestrian friendly.
- The following design features should be incorporated to enhance aesthetics where possible:
  - Provide pedestrian access to shallow pool areas enhanced with emergent wetland vegetation. This allows the pond to be more accessible without incurring safety risks.
  - Provide side slopes that are sufficiently gentle to avoid the need for fencing (3H:1V or flatter).

- Create flat areas overlooking or adjoining the pond for picnic tables or seating that can be used by residents. Walking or jogging trails around the pond are easily integrated into site design.
- Include fountains or integrated waterfall features for privately maintained facilities.
- Provide visual enhancement with clusters of trees and shrubs. On most pond sites, it is important to amend the soil before planting since ponds are typically placed well below the native soil horizon in very poor soils. Make sure dam safety restrictions against planting do not apply.
- Orient the pond length along the direction of prevailing summer winds (typically west or southwest) to enhance wind mixing.

**Table 5 - 16: Emergent Wetland Species Recommended for Wetponds**

Species	Common Name	Notes	Maximum Depth
<b>Inundation to 1-Foot</b>			
<i>Agrostis exarata</i> <sup>(1)</sup>	Spike bent grass	Prairie to coast	2 feet
<i>Carex stipata</i>	Sawbeak sedge	Wet ground	
<i>Eleocharis palustris</i>	Spike rush	Margins of ponds, wet meadows	2 feet
<i>Glyceria occidentalis</i>	Western mannagrass	Marshes, pond margins	2 feet
<i>Juncus tenuis</i>	Slender rush	Wet soils, wetland margins	
<i>Oenanthe sarmentosa</i>	Water parsley	Shallow water along stream and pond margins; needs saturated soils all summer	
<i>Scirpus atrocinctus</i> (formerly <i>S. cyperinus</i> )	Woolgrass	Tolerates shallow water; tall clumps	
<i>Scirpus microcarpus</i>	Small-fruited bulrush	Wet ground to 18 inches depth	18 inches
<i>Sagittaria latifolia</i>	Arrowhead	Prairie to coast	
<b>Inundation 1 to 2 Feet</b>			
<i>Agrostis exarata</i> <sup>(1)</sup>	Spike bent grass	Prairie to coast	
<i>Alisma plantago-aquatica</i>	Water plantain		
<i>Eleocharis palustris</i>	Spike rush	Margins of ponds, wet meadows	
<i>Glyceria occidentalis</i>	Western mannagrass	Marshes, pond margins	
<i>Juncus effusus</i>	Soft rush	Wet meadows, pastures, wetland margins	
<i>Scirpus microcarpus</i>	Small-fruited bulrush	Wet ground to 18 inches depth	18 inches
<i>Sparganium emmersum</i>	Bur reed	Shallow standing water, saturated soils	
<b>Inundation 1 to 3 Feet</b>			
<i>Carex obnupta</i>	Slough sedge	Wet ground or standing water	1.5 to 3 feet
<i>Beckmania syzigachne</i> <sup>(1)</sup>	Western sloughgrass	Wet prairie to pond margins	
<i>Scirpus acutus</i> <sup>(2)</sup>	Hardstem bulrush	Single tall stems, not clumping	3 feet
<i>Scirpus validus</i> <sup>(2)</sup>	Softstem bulrush		
<b>Inundation Greater Than 3 Feet</b>			
<i>Nuphar polysepalum</i>	Spatterdock	Deep water	3 to 7.5 feet
<i>Nymphaea odorata</i> <sup>(1)</sup>	White waterlily	Shallow to deep ponds	6 feet

**Notes:**

(1) Non-native species. *Beckmania syzigachne* is native to Oregon. Native species are preferred.

(2) *Scirpus* tubers must be planted shallower for establishment, and protected from foraging waterfowl until established. Emerging aerial stems should project above water surface to allow oxygen transport to the roots.

Primary sources: Municipality of Metropolitan Seattle, *Water Pollution Control Aspects of Aquatic Plants*, 1990. *Hortus Northwest*, *Wetland Plants for Western Oregon*, Issue 2, 1991. Hitchcock and Cronquist, *Flora of the Pacific Northwest*, 1973.

**11.2.1.11 Construction Criteria**

- Remove sediment that has accumulated in the pond after construction in the drainage area of the pond is complete (unless used for a liner - see below).
- Sediment that has accumulated in the pond at the end of construction may be used as a liner in excessively drained soils if the sediment meets the criteria for low permeability or treatment liners in keeping with guidance given in Chapter 3. Sediment used for a soil liner must be graded to provide uniform coverage and must meet the thickness specifications in Chapter 3. The sediment must not reduce the design volume of the pond. The pond must be over-excavated initially to provide sufficient room for the sediments to serve as a liner.

**11.2.1.12 Maintenance**

Per Minimum Requirement #9, an operation and maintenance plan shall be prepared for all stormwater management facilities. See Volume 1, Appendix C, Maintenance Checklist #12 for specific maintenance requirements for wet ponds. Maintenance shall be a basic consideration in design and cost-determination of the stormwater management facility.

Any standing water removed during maintenance operation must be disposed of in a City approved manner. See the dewatering requirements in Volume 4, Appendix D of this manual. Pretreatment may be necessary. Solids must be disposed of in accordance with state and local waste regulations.

Facilities shall be designed and constructed such that the facility can be safely and easily inspected by one person and safely and easily maintained. This may require construction of additional inspection ports or access manholes to allow inspection access to be opened by one person.

## **11.2.2 BMP T1120 Wetvaults**

### **11.2.2.1 Description**

A wetvault is an underground structure similar in appearance to a detention vault, except that a wetvault has a permanent pool of water (wetpool) which dissipates energy and improves the settling of particulate pollutants (see the wetvault details in Figure 5 - 27). Being underground, the wetvault lacks the biological pollutant removal mechanisms, such as algae uptake, present in surface wetponds.

### **11.2.2.2 Applications and Limitations:**

A wetvault may be used for commercial, industrial, or roadway projects if there are space limitations precluding the use of other treatment BMPs. The use of wetvaults for residential development is highly discouraged. Combined detention and wetpools are allowed; see BMP T1040.

If oil control is required for a project, a wetvault may be combined with an API oil/water separator.

### **11.2.2.3 Design Criteria**

#### ***Sizing Procedure***

The wetpool volume for the wetvault shall be equal to or greater than the total volume of runoff from the 6-month, 24-hour storm event. Alternatively, the water quality design storm volume shall be equal to the simulated daily volume indicated by WWHM that represents the upper limit of the range of daily volumes that accounts for 91% of the entire runoff volume over a multi-decade period of record.

Typical design details and concepts for the wetvault are shown in Figure 5 - 27.



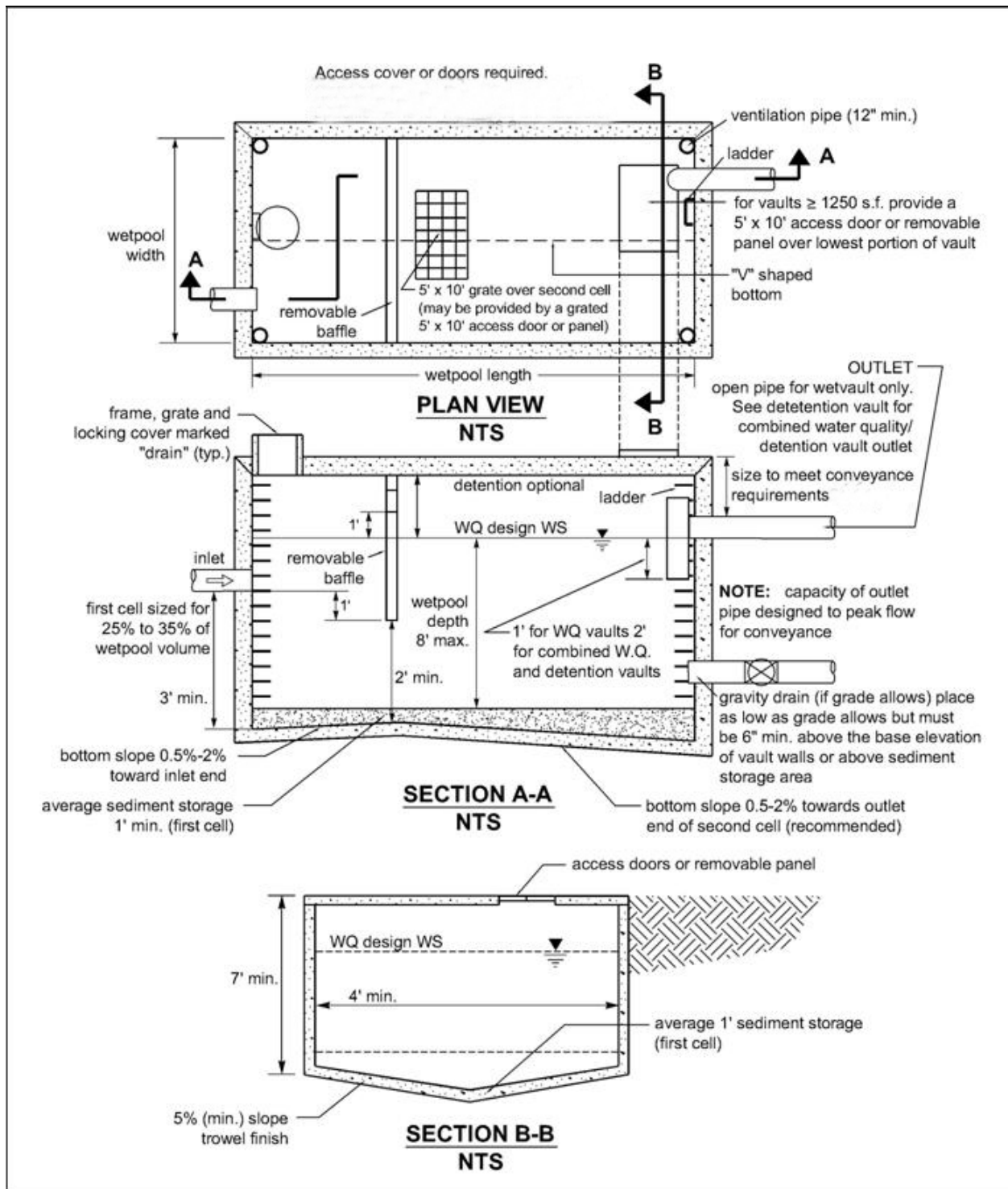


Figure 5 - 27. Wetvault

**11.2.2.4 Wetpool Geometry**

Same as specified for wetponds (see BMP T1010) except for the following two modifications:

- The sediment storage in the first cell shall be an average of 1-foot. Because of the v-shaped bottom, the depth of sediment storage needed above the bottom of the side wall is roughly proportional to vault width according to the schedule below:

Vault Width	Sediment Depth (from bottom of side wall)
15'	10"
20'	9"
40'	6"
60'	4"

- The second cell shall be a minimum of 3 feet deep since planting cannot be used to prevent re-suspension of sediment in shallow water as it can in open ponds.

**11.2.2.5 Vault Structure**

- Separate the vault into two cells by a wall or a removable baffle. If a wall is used, provide a 5-foot by 10-foot removable maintenance access for both cells. If a removable baffle is used, the following criteria apply:
  - The baffle shall extend from a minimum of 1-foot above the WQ design water surface to a minimum of 1-foot below the invert elevation of the inlet pipe.
  - The lowest point of the baffle shall be a minimum of 2 feet from the bottom of the vault, and greater if feasible.
- If the vault is less than 2,000 cubic feet (inside dimensions), or if the length-to-width ratio of the vault pool is 5:1 or greater, the baffle or wall may be omitted and the vault may be one-celled.
- Do not divide the two cells of a wetvault into additional subcells by internal walls. If internal structural support is needed, it is preferred that post and pier construction be used to support the vault lid rather than walls. Any walls used within cells must be positioned so as to lengthen, rather than divide, the flowpath.
- Slope the bottom of the first cell toward the access opening. Slope shall be between 0.5 percent (minimum) and 2 percent (maximum). The second cell may be level (longitudinally) sloped toward the outlet, with a high point between the first and second cells. Sloping the second cell towards the access opening for the first cell is also acceptable. Alternatively, access openings may be positioned a maximum of 10 feet from any location within the vault.
- Slope the vault bottom laterally a minimum of 5 percent from each side towards the center, forming a broad "v" to facilitate sediment removal. Note: More than one "v" may be used to minimize vault depth.
- The City may allow the vault bottom to be flat if removable panels are provided over the entire vault. Removable panels shall be at grade, have stainless steel lifting eyes, and weigh no more than 5 tons per panel.
- The highest point of a vault bottom must be at least 6 inches below the outlet elevation to provide for sediment storage over the entire bottom.
- Evaluate buoyancy of the vault with the results presented in design documentation.

- Wetvaults may be constructed using arch culvert sections provided the top area at the WQ design water surface is, at a minimum, equal to that of a vault with vertical walls designed with an average depth of 6 feet.
- Wetvaults shall conform to the "Materials" and "Structural Stability" criteria specified for detention vaults in Volume 3, Section 7.4.1.
- Where pipes enter and leave the vault below the WQ design water surface, they shall be sealed using water tight seals or couplers.
- Bare galvanized materials shall not be used.

#### **11.2.2.6 Inlet and Outlet**

- Submerge the inlet to the wetvault. The inlet pipe invert shall be a minimum of 3 feet from the vault bottom. Submerge the top of the inlet pipe at least 1-foot, if possible.
- Unless designed as an offline facility, the capacity of the outlet pipe and available head above the outlet pipe shall be designed to convey the 100-year design flow for developed site conditions without overtopping the vault. The available head above the outlet pipe must be a minimum of 6 inches.
- The outlet pipe shall be back-sloped or have tee section, the lower arm of which shall extend 1 foot below the WQ design water surface to provide for trapping of oils and floatables in the vault.
- Center the inlet and outlet pipes over the "V" portion of the vault.

#### **11.2.2.7 Access Requirements**

Same as for detention vaults (see Volume 3, Section 7.4.1.4), except for the following additional requirement for wetvaults:

- Provide a minimum of 50 square feet of grate over the second cell. For vaults in which the surface area of the second cell is greater than 1,250 square feet, grate 4 percent of the top. This requirement may be met by one grate or by many smaller grates distributed over the second cell area.

**NOTE:** A grated access door can be used to meet this requirement.

#### **11.2.2.8 Access Roads, Right of Way, and Setbacks**

Same as for detention vaults (see Volume 3, Section 7.4.1.4).

#### **11.2.2.9 Recommended Design Features**

The following design features should be incorporated into wetvaults where feasible, but they are not specifically required:

- The floor of the second cell should slope toward the outlet for ease of cleaning.
- The inlet and outlet should be at opposing corners of the vault to increase the flowpath.
- A flow length-to-width ratio greater than 3:1 minimum is desirable.
- Lockable grates instead of solid manhole covers are recommended to increase air contact with the wetpool.
- The number of inlets to the wetvault should be limited, and the flowpath length should be maximized from inlet to outlet for all inlets to the vault.

### **11.2.2.10 Construction Criteria**

Remove sediment that has accumulated in the vault after construction in the drainage area is complete.

### **11.2.2.11 Maintenance**

Per Minimum Requirement #9, an operation and maintenance plan shall be prepared for all stormwater management facilities. See Volume 1, Appendix C, Maintenance Checklist #14 for specific maintenance requirements for wet vaults. Maintenance shall be a basic consideration in design and cost-determination of the stormwater management facility.

Any standing water removed during maintenance operation must be disposed of in a City approved manner. See the dewatering requirements in Volume 4, Appendix D of this manual. Pretreatment may be necessary. Solids must be disposed of in accordance with state and local waste regulations.

Facilities shall be designed and constructed such that the facility can be safely and easily inspected by one person and safely and easily maintained. This may require construction of additional inspection ports or access manholes to allow inspection access to be opened by one person.

### **11.2.2.12 Modifications for Combining with a Baffle Oil/Water Separator**

If the project site is a high-use site and a wetvault is proposed, the vault may be combined with a baffle oil/water separator to meet the runoff treatment requirements with one facility rather than two.

- The sizing procedures for the baffle oil/water separator (Chapter 9) shall be run as a check to ensure the vault is large enough. If the oil/water separator sizing procedures result in a larger vault size, increase the wetvault size to match.
- An oil retaining baffle shall be provided in the second cell near the vault outlet. The baffle shall not contain a high-flow overflow, or else the retained oil will be washed out of the vault during large storms.
- The vault shall have a minimum length-to-width ratio of 5:1.
- The vault shall have a design water depth-to-width ratio of between 1:3 to 1:2.
- The vault shall be watertight and shall be coated to protect from corrosion.
- Separator vaults shall have a shutoff mechanism on the outlet pipe to prevent oil discharges during maintenance and to provide emergency shut-off capability in case of a spill. Also, provide a valve box and riser.
- Wetvaults used as oil/water separators must be offline and must bypass flows greater than the offline WQ design flow multiplied by 3.5. This will minimize the entrainment and/or emulsification of previously captured oil during very high flow events.

## **11.2.3 BMP T1130 Stormwater Treatment Wetlands**

### **11.2.3.1 Description**

Stormwater treatment wetlands are shallow man-made ponds that are designed to treat stormwater through the biological processes associated with emergent aquatic plants (see the stormwater wetland details in Figure 5 - 28 and Figure 5 - 29).

Wetlands created to mitigate disturbance impacts, such as filling of wetlands, shall not be used as stormwater treatment facilities.

### **11.2.3.2 Applications and Limitations**

The most critical factor for a successful design is the provision of an adequate supply of water for most of the year. Since water depths are shallower than in wetponds, water loss by evaporation is an important concern. Stormwater wetlands are a good WQ facility choice in areas with high winter groundwater levels.

### **11.2.3.3 Design Criteria**

Stormwater wetlands use most of the same design criteria as wetponds. However, instead of gravity settling being the dominant treatment process, pollutant removal mediated by aquatic vegetation and the microbiological community associated with that vegetation becomes the dominant treatment process. Thus when designing wetlands, water volume is not the dominant design criteria. Rather, factors which affect plant vigor and biomass are the primary concerns.

### **11.2.3.4 Sizing Procedure**

1. The design volume is the total volume of runoff from the 6-month, 24-hour storm event or, alternatively, the water quality design storm volume estimated by WWHM.
2. Calculate the surface area of the stormwater wetland. The surface area of the wetland shall be the same as the top area of a wetpond sized for the same site conditions. Calculate the surface area of the stormwater wetland by using the volume from Step 1 and dividing by the average water depth (use 3 feet).
3. Determine the surface area of the first cell of the stormwater wetland. Use the volume determined from Criterion 2 under "Wetland Geometry", below, and the actual depth of the first cell.
4. Determine the surface area of the wetland cell. Subtract the surface area of the first cell (Step 3) from the total surface area (Step 2).
5. Determine water depth distribution in the second cell. Decide if the top of the dividing berm will be at the surface or submerged (designer's choice). Adjust the distribution of water depths in the second cell according to Step 8 in Section 11.2.3.5. This will result in a facility that holds less volume than that determined in Step 1 above. This is acceptable.
6. Choose plants. See Table 5 - 16 for a list of plants recommended for wetpond water depth zones, or consult a wetland scientist.

### 11.2.3.5 Wetland Geometry

1. Stormwater wetlands shall consist of two cells, a presettling cell and a wetland cell.
2. The presettling cell shall contain approximately 33 percent of the wetpool volume calculated in Step 1 above.
3. The depth of the presettling cell shall be between 4 feet (minimum) and 8 feet (maximum), excluding sediment storage.
4. Provide one-foot of sediment storage in the presettling cell.
5. The wetland cell shall have an average water depth of about 1.5 feet (plus or minus 3 inches).
6. Shape the "berm" separating the two cells such that its downstream side gradually slopes to form the second shallow wetland cell (see the section view in Figure 5 - 28). Alternatively, the second cell may be graded naturalistically from the top of the dividing berm (see Step 8 below).
7. The top of the berm shall be either at the WQ design water surface or submerged 1-foot below the WQ design water surface. Correspondingly, the side slopes of the berm must meet the following criteria:
  - a. If the top of berm is at the WQ design water surface, the berm side slopes shall be no steeper than 3H:1V.
  - b. If the top of berm is submerged 1-foot, the upstream side slope may be up to 2H:1V.
8. Grade the bottom of the wetland cell in one of two ways:
  - a. Shallow evenly graded slope from the upstream to the downstream edge of the wetland cell (see Figure 5 - 28).
  - b. A "naturalistic" alternative, with the specified range of depths intermixed throughout the second cell (see Figure 5 - 29). A distribution of depths shall be provided in the wetland cell depending on whether the dividing berm is at the water surface or submerged.

The maximum depth shall be 2.5 feet in either configuration.

### 11.2.3.6 Lining Requirements

In infiltrative soils, line both cells of the stormwater wetland. To determine whether a low-permeability liner or a treatment liner is required, determine whether the following conditions will be met. If soil permeability will allow sufficient water retention, lining may be waived.

1. The second cell must retain water for at least 10 months of the year.
2. The first cell must retain at least three feet of water year-round.
3. Use a complete precipitation record when establishing these conditions. Take into account evapotranspiration losses as well as infiltration losses. Many wetland plants can adapt to periods of summer drought, so a limited drought period is allowed in the second cell. This may allow a treatment liner rather than a low permeability liner to be used for the second cell. The first cell must retain water year-round in order for the presettling function to be effective.

4. If a low permeability liner is used, place a minimum of 18 inches of native soil amended with good topsoil or compost (one part compost mixed with 3 parts native soil) over the liner. For geomembrane liners, a soil depth of 3 feet is recommended to prevent damage to the liner during planting. Hydric soils are not required.

The criteria for liners given in Chapter 4 must be observed.

#### **11.2.3.7 Inlet and Outlet**

Same as for wetponds (see BMP T1010).

#### **11.2.3.8 Access and Setbacks**

Access shall be the same as for detention ponds.

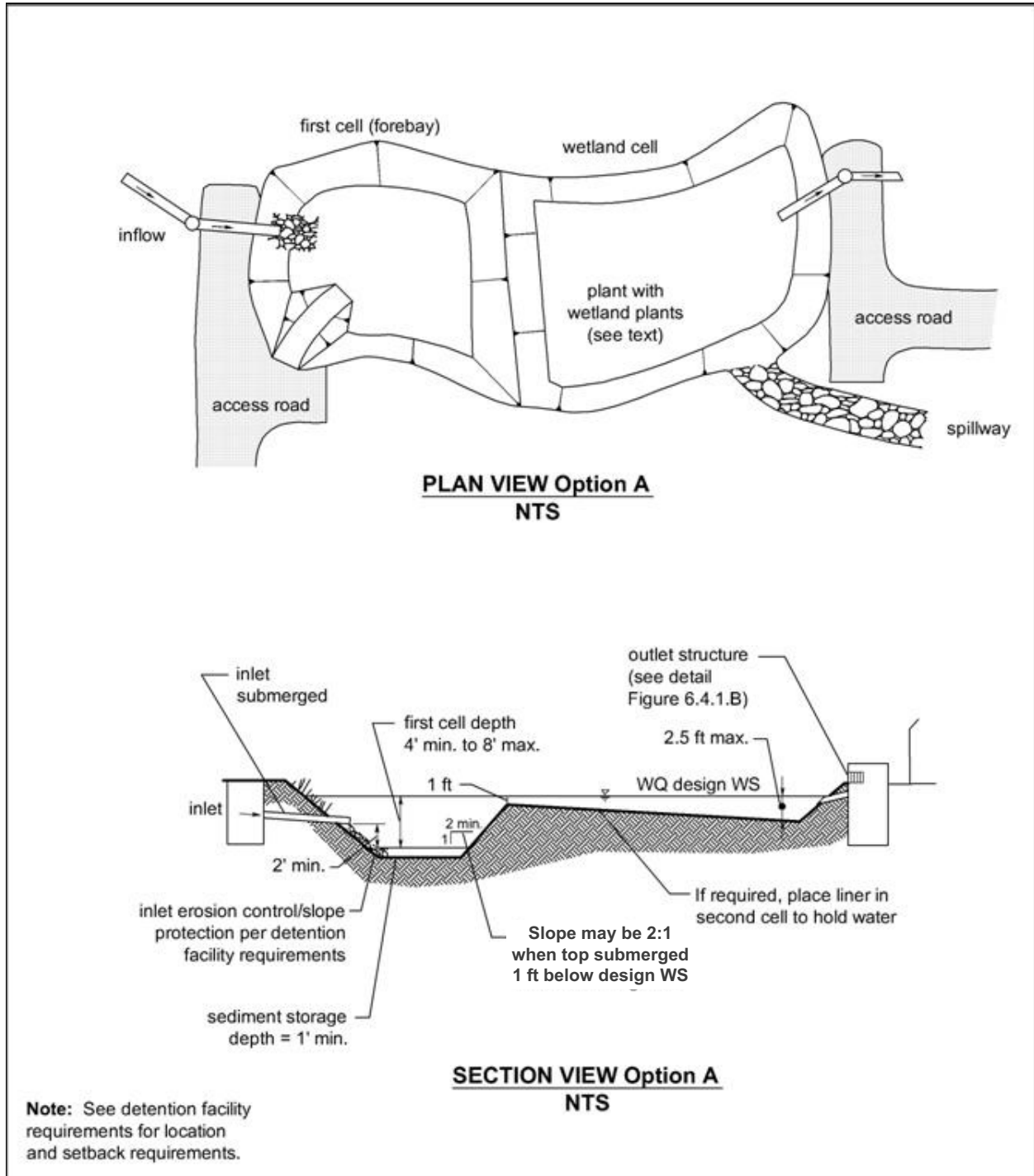


Figure 5 - 28. Stormwater Wetland – Option 1



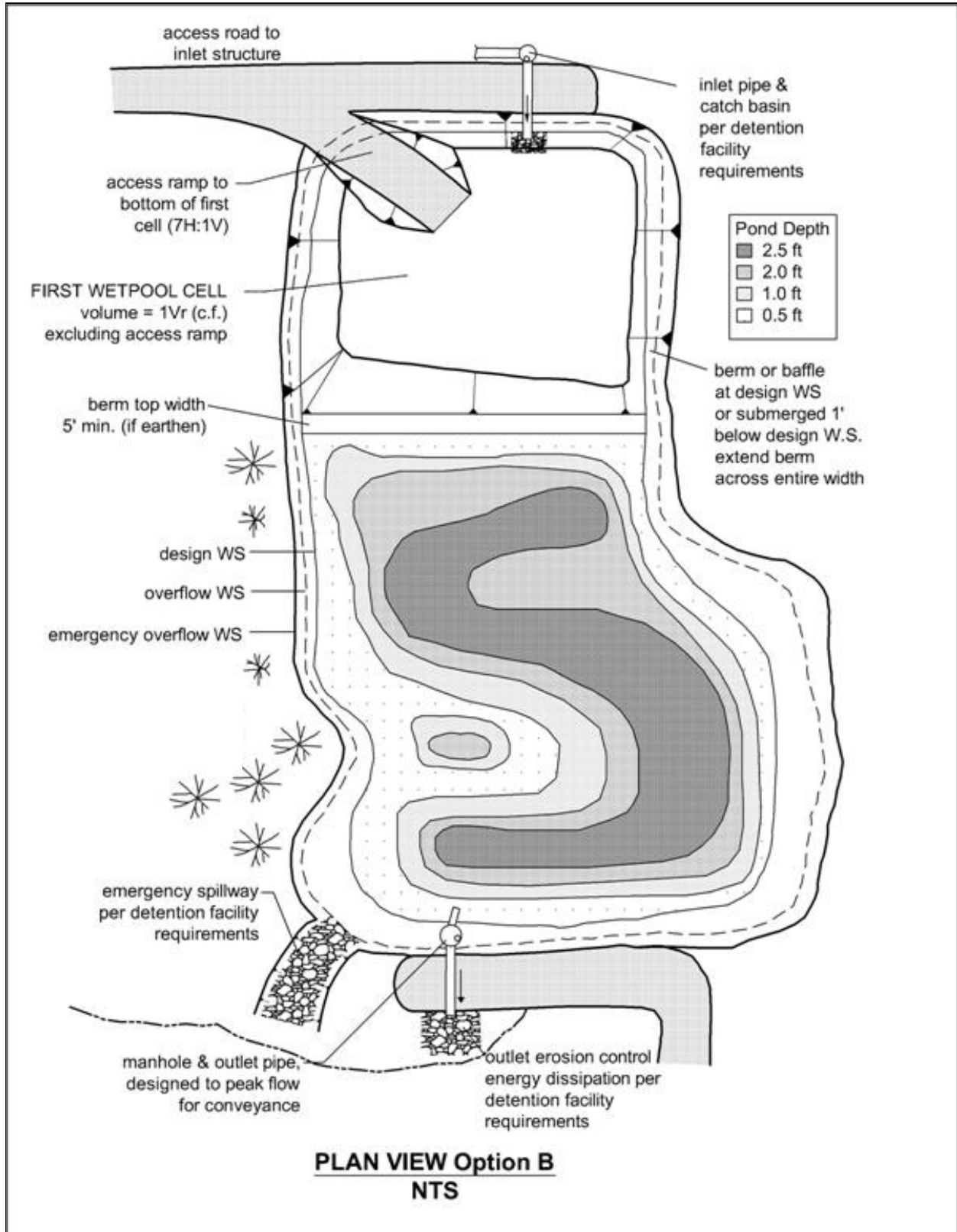


Figure 5 - 29. Stormwater Wetland – Option 2

**Table 5 - 17: Distribution of Depths in Wetland Cell**

Dividing Berm at WQ Design Water Surface		Dividing Berm Submerged 1-Foot	
Depth Range (feet)	Percent	Depth Range (feet)	Percent
0.1 to 1	25	1 to 1.5	40
1 to 2	55	1.5 to 2	40
2 to 2.5	20	2 to 2.5	20

### 11.2.3.9 Planting Requirements

Plant the wetland cell with emergent wetland plants following the recommendations given in Table 5 - 16 or the recommendations of a wetland specialist. Cattails (*Typha latifolia*) are not allowed. Provide a planting plan showing mature plant coverage and species type.

### 11.2.3.10 Construction Criteria

- Construction and maintenance considerations are the same as for wetponds.
- Construction of the naturalistic alternative (Option 2) can be accomplished by first excavating the entire area to the 1.5-foot average depth. Then soil subsequently excavated to form deeper areas can be deposited to raise other areas until the distribution of depths indicated in the design is achieved.

### 11.2.3.11 Maintenance

Per Minimum Requirement #9, an operation and maintenance plan shall be prepared for all stormwater management facilities. See Volume 1, Appendix C, Maintenance Checklist #13 for specific maintenance requirements for treatment wetlands. Maintenance shall be a basic consideration in design and cost-determination of the stormwater management facility.

Any standing water removed during maintenance operation must be disposed of in a City approved manner. See the dewatering requirements in Volume 4, Appendix D of this manual. Pretreatment may be necessary. Solids must be disposed of in accordance with state and local waste regulations.

Facilities shall be designed and constructed such that the facility can be safely and easily inspected by one person and safely and easily maintained.

## **11.2.4 BMP T1140 Combined Detention and Wetpool Facilities**

### **11.2.4.1 Description**

Combined detention and WQ wetpool facilities have the appearance of a detention facility but contain a permanent pool of water as well. The following design procedures, requirements, and recommendations cover differences in the design of the stand-alone WQ facility when combined with detention storage. The following combined facilities are addressed:

- Detention/wetpond (basic and large)
- Detention/wetvault
- Detention/stormwater wetland.

There are two sizes of the combined wetpond, a basic and a large, but only a basic size for the combined wetvault and combined stormwater wetland. The facility sizes (basic and large) are related to the pollutant removal goals. See Chapter 3 for more information about treatment performance goals.

### **11.2.4.2 Applications and Limitations:**

Combined detention and water quality facilities are efficient for sites that also have detention requirements. The water quality facility may often be placed beneath the detention facility without increasing the facility surface area. However, the fluctuating water surface of the live storage will create unique challenges for plant growth and for aesthetics alike.

The live storage component of the facility shall be provided above the seasonal high water table.

### **11.2.4.3 Design Criteria**

Typical design details and concepts for a combined detention and wetpond are shown in Figure 5 - 30 and Figure 5 - 31. The detention portion of the facility shall meet the design criteria and sizing procedures set forth in Volume 3.

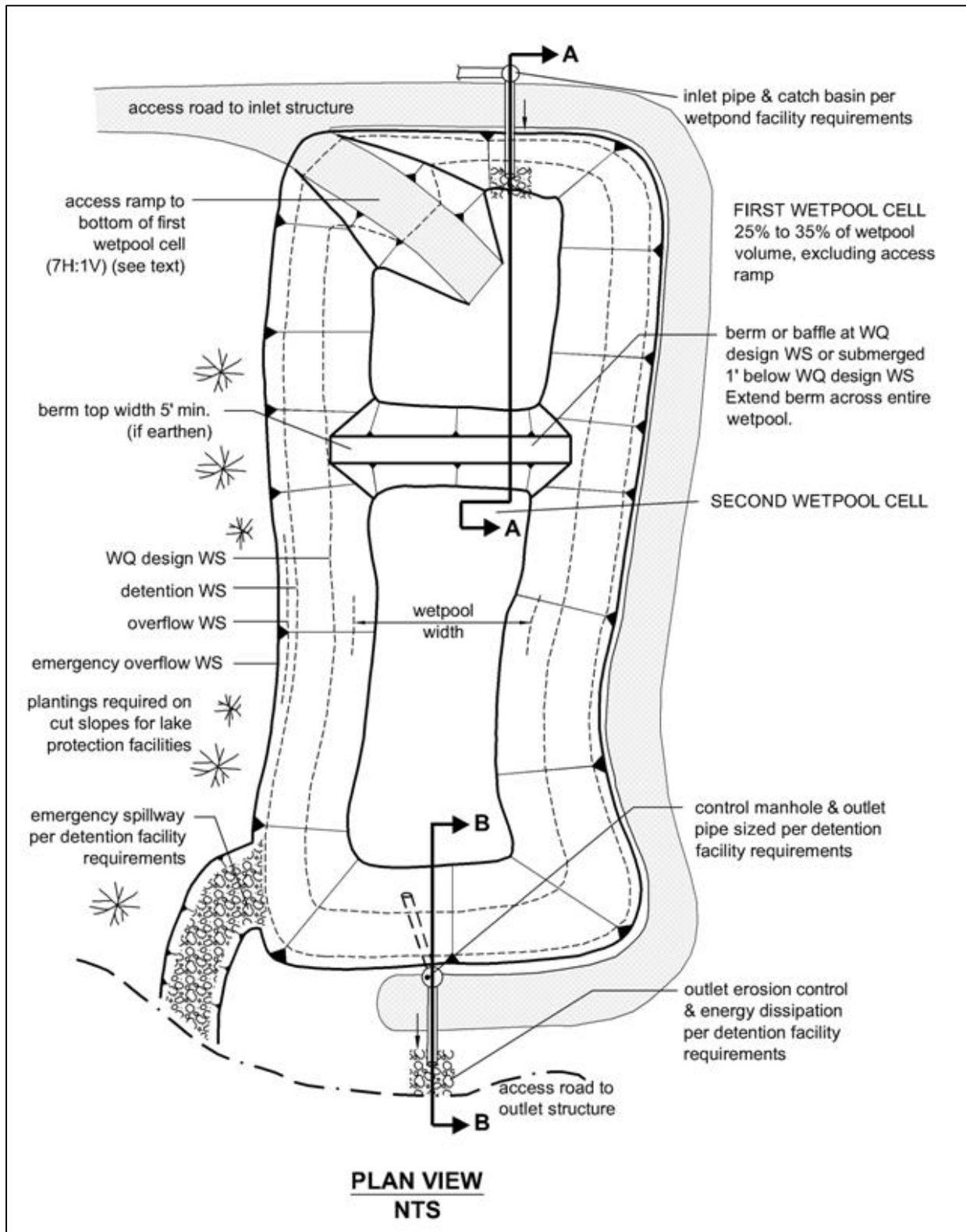


Figure 5 - 30. Combined Detention and Wetpond (top view)

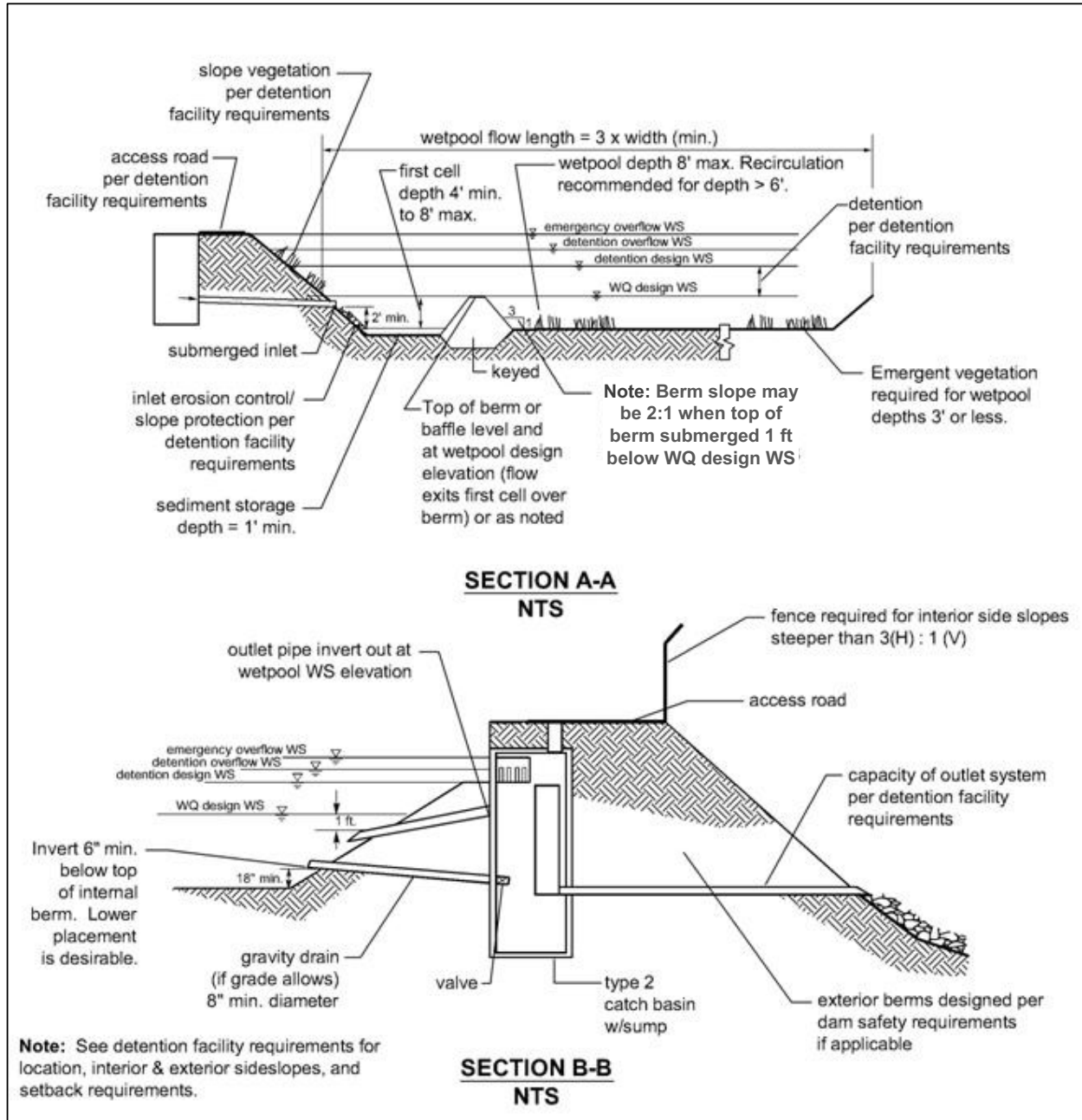


Figure 5 - 31. Combined Detention and Wetpond (side view)

### 11.2.4.4 Sizing

The sizing for combined detention and wetponds are identical to those for wetponds and for detention facilities. The wetpool volume for a combined facility shall be equal to or greater than the total volume of runoff from the 6-month, 24-hour storm event or the water quality design storm volume estimated by WWHM. Follow the standard procedure specified in Volume 3 to size the detention portion of the pond.

#### **11.2.4.5 Detention and Wetpool Geometry**

- Do not include the wetpool and sediment storage volumes in the required detention volume.
- The "Wetpool Geometry" criteria for wetponds (see BMP T1010) shall apply with the following modifications/clarifications:
  - The permanent pool may be shallower to comprise most of the pond bottom, or deeper positioned to comprise a limited portion of the bottom. Note, having the first wetpool cell at the inlet allows for more efficient sediment management than if the cell is moved away from the inlet. Wetpond criteria governing water depth must still be met. See Figure 5 - 32 for two possibilities for wetpool cell placement.
  - The minimum sediment storage depth in the first cell is 1-foot. The 6 inches of sediment storage required for a detention pond does not need to be added to this, but 6 inches of sediment storage must be added to the second cell to comply with the detention sediment storage requirement.

#### **11.2.4.6 Berms, Baffles and Slopes**

Same as for wetponds (see BMP T1010)

#### **11.2.4.7 Inlet and Outlet**

The Inlet and Outlet criteria for wetponds shall apply with the following modifications:

- Provide a sump in the outlet structure of combined ponds.
- Design the detention flow restrictor and its outlet pipe according to the requirements for detention ponds (see Volume 3).

#### **11.2.4.8 Access and Setbacks**

The same as for wetponds.

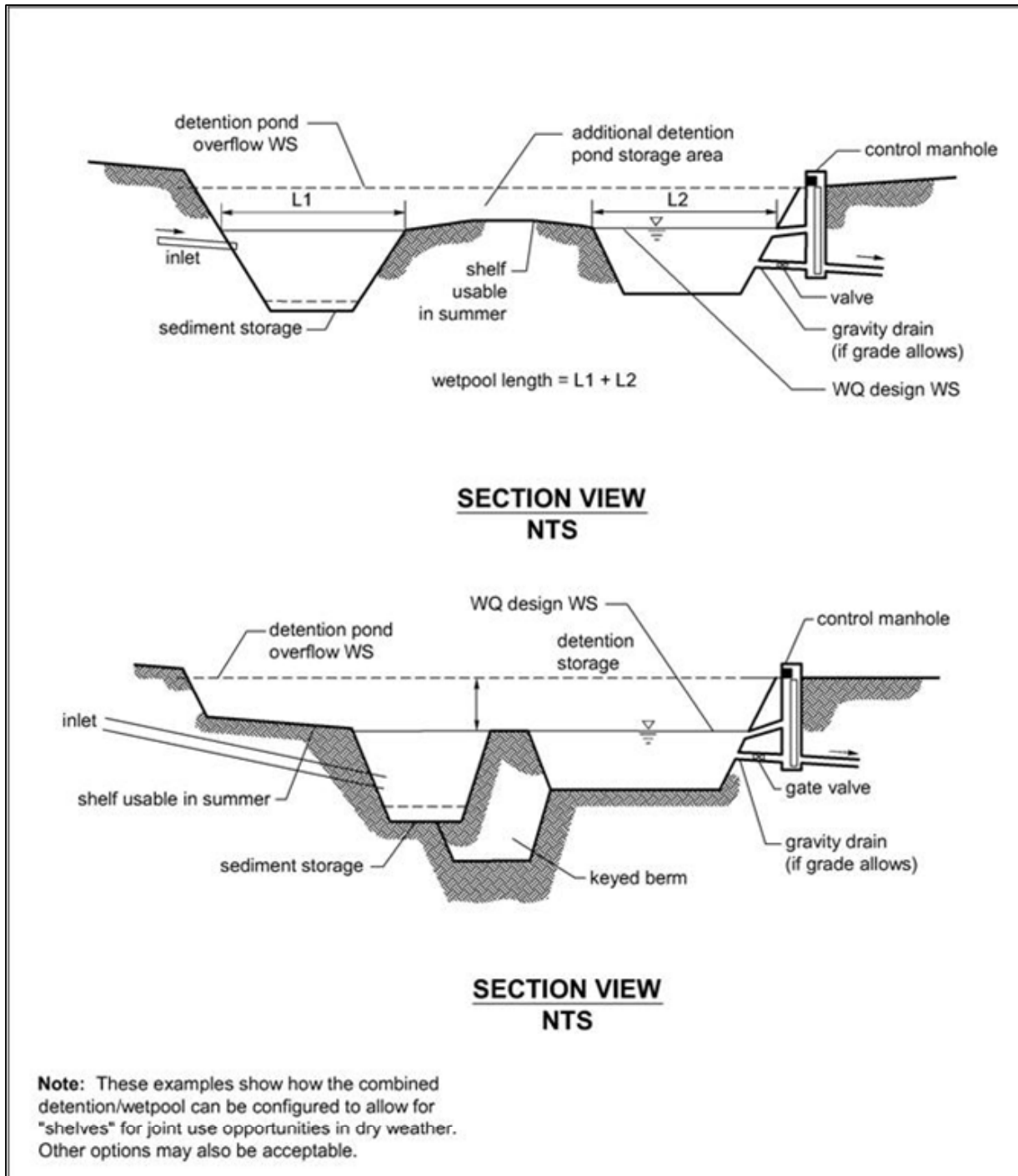
#### **11.2.4.9 Planting Requirements**

The same as for wetponds.

### **11.3 Combined Detention and Wetvault**

The sizing procedure for combined detention and wetvaults is identical to those outlined for wetvaults and for detention facilities. The design criteria for detention vaults and wetvaults must both be met, except for the following modifications or clarifications:

- The minimum sediment storage depth in the first cell shall average 1-foot. The 6 inches of sediment storage required for detention vaults do not need to be added to this, but 6 inches of sediment storage must be added to the second cell to comply with detention vault sediment storage requirements.
- The oil retaining baffle shall extend a minimum of 2 feet below the WQ design water surface.
- If a vault is used for detention as well as water quality control, the facility may not be modified to function as a baffle oil/water separator as allowed for wetvaults in BMP T1020.



**Figure 5 - 32. Alternative Configurations of Detention and Wetpool Areas**

## 11.4 Combined Detention and Stormwater Wetland

### 11.4.1 Sizing Criteria

The sizing procedure for combined detention and stormwater wetlands is identical to those outlined for stormwater wetlands and for detention facilities. Follow the procedure specified in BMP T1030 to determine the stormwater wetland size. Follow the standard procedure specified in Volume 3 to size the detention portion of the wetland.

Water Level Fluctuation Restrictions: The difference between the WQ design water surface and the maximum water surface associated with the 2-year runoff shall not be greater than 3 feet. If this restriction cannot be met, the size of the stormwater wetland must be increased. The additional area may be placed in the first cell, second cell, or both. If placed in the second cell, the additional area need not be planted with wetland vegetation or counted in calculating the average depth.

### 11.4.2 Design Criteria

The design criteria for detention ponds and stormwater wetlands must both be met, except for the following modifications or clarifications. The Wetland Geometry criteria for stormwater wetlands (see BMP T1030) shall be modified as follows:

- The minimum sediment storage depth in the first cell is 1-foot. The 6 inches of sediment storage required for detention ponds does not need to be added to this, nor does the 6 inches of sediment storage in the second cell of detention ponds need to be added.

### 11.4.3 Inlet and Outlet Criteria

The Inlet and Outlet criteria for wetponds shall apply with the following modifications:

- Provide a sump in the outlet structure of combined facilities.
- Design the detention flow restrictor and its outlet pipe according to the requirements for detention ponds (see Volume 3).

### 11.4.4 Planting Requirements

The Planting Requirements for stormwater wetlands are modified to use the following plants which are better adapted to water level fluctuations:

- |  |                |
|--|----------------|
| • <i>Scirpus acutus</i> (hardstem bulrush)           | 2 - 6' depth   |
| • <i>Scirpus microcarpus</i> (small-fruited bulrush) | 1 - 2.5' depth |
| • <i>Sparganium emersum</i> (burreed)                | 1 - 2' depth   |
| • <i>Sparganium eurycarpum</i> (burreed)             | 1 - 2' depth   |
| • <i>Veronica</i> sp. (marsh speedwell)              | 0 - 1' depth   |

In addition, the shrub *Spirea douglasii* (Douglas spirea) may be used in combined facilities. Provide a planting plan showing mature plant coverage and species type.



**This Page Intentionally Left Blank**

## Chapter 12 Oil Water Separators

### 12.1 Purpose

Oil water separators remove oil and other water-insoluble hydrocarbons and settleable solids from stormwater runoff. This chapter provides a discussion of their application and design criteria. BMPs are described for baffle type and coalescing plate separators.

### 12.2 Description

Oil water separators are typically the American Petroleum Institute (API) (also called baffle type) (American Petroleum Institute, 1990) or the coalescing plate (CP) type using a gravity mechanism for separation. See Figure 5 - 33 and Figure 5 - 34. Oil water separators typically consist of three bays; forebay, separator section, and the afterbay. The CP separators need considerably less space for separation of the floating oil due to the shorter travel distances between parallel plates. A spill control (SC) separator (Figure 5 - 35) is a simple catch basin with a T-inlet for temporarily trapping small volumes of oil. The spill control separator is included here for comparison only and is not designed for, or to be used for, treatment purposes.

### 12.3 Applications/Limitations

This BMP is specific for discharges to the stormwater system. Oil water separators that will discharge to the sanitary sewer system shall follow the “City of Tacoma Environmental Services Source Control Oil Water Separator Policy” available at [www.cityoftacoma.org/stormwater](http://www.cityoftacoma.org/stormwater).

For low concentrations of oil, other treatments may be more applicable. These include sand filters and emerging technologies.

Without intense maintenance oil/water separators may not be sufficiently effective in achieving oil and TPH removal down to required levels.

Pretreatment should be considered if the level of total suspended solids (TSS) in the inlet flow would cause clogging or otherwise impair the long-term efficiency of the separator.

For inflows from small drainage areas (fueling stations, maintenance shops, etc.) a coalescing plate (CP) type separator is typically considered, due to space limitations. However, if plugging of the plates is likely, then a new design basis for the baffle type API separator may be considered on an experimental basis (see Section 12.6).

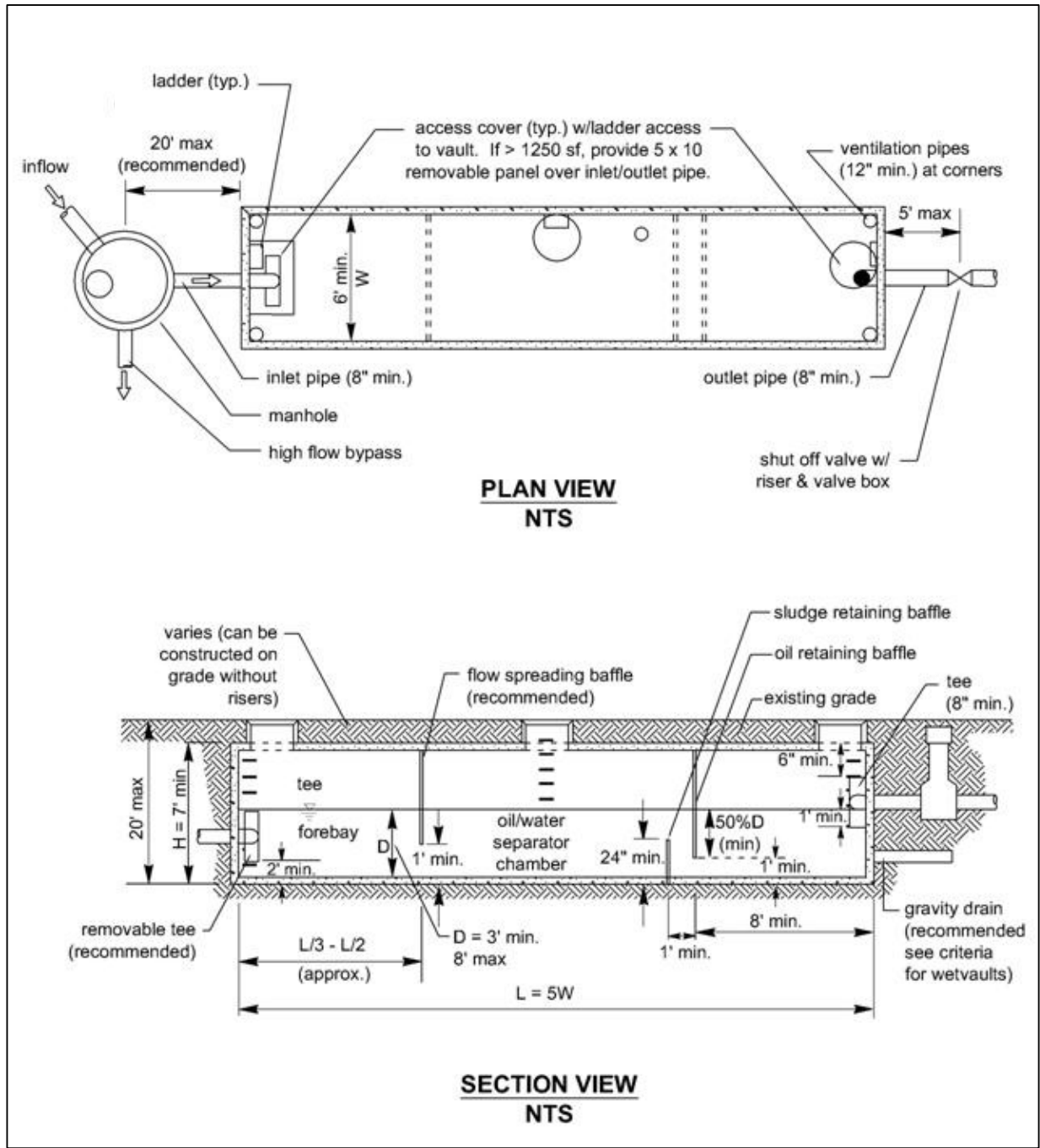


Figure 5 - 33. API (Baffle Type) Separator

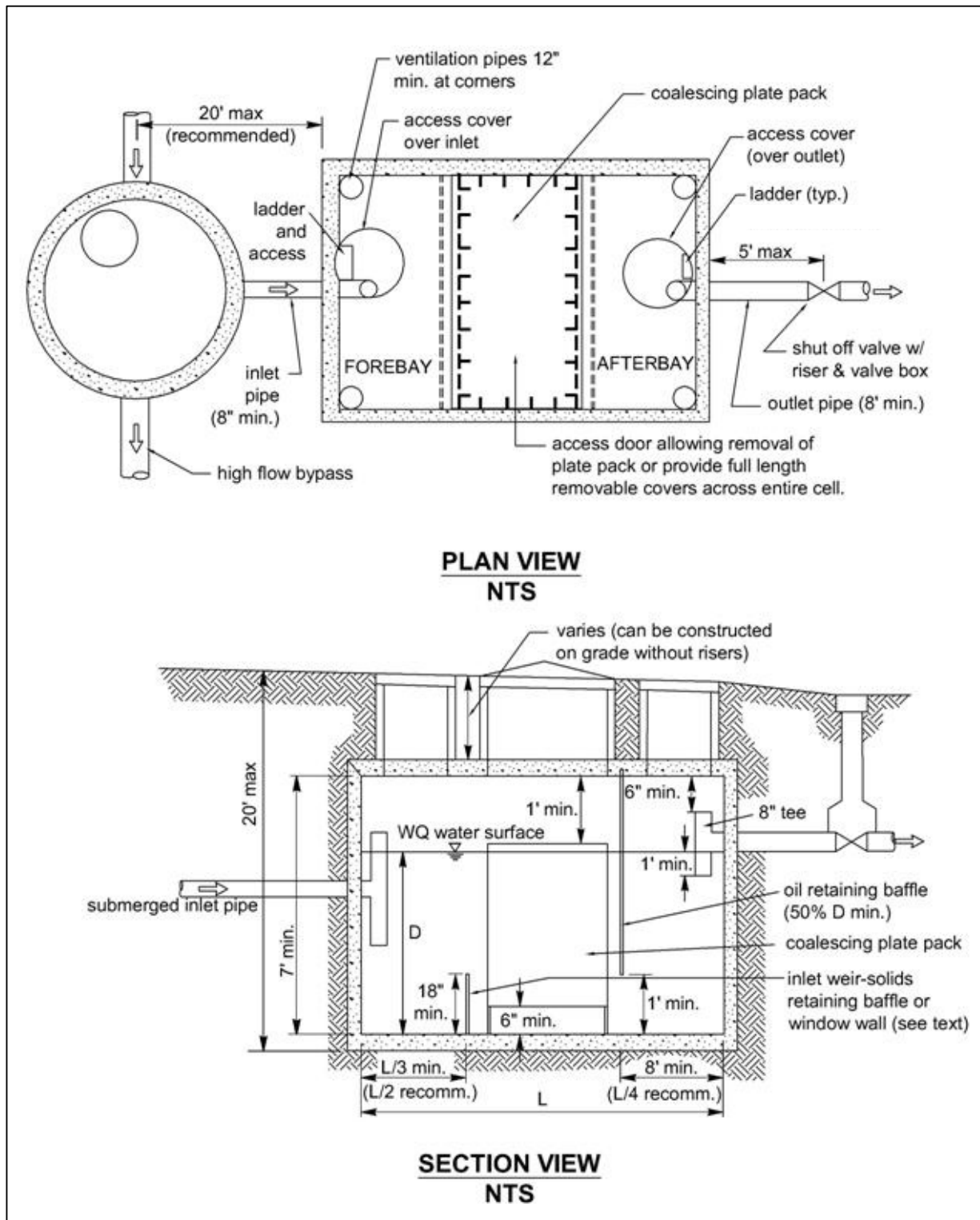
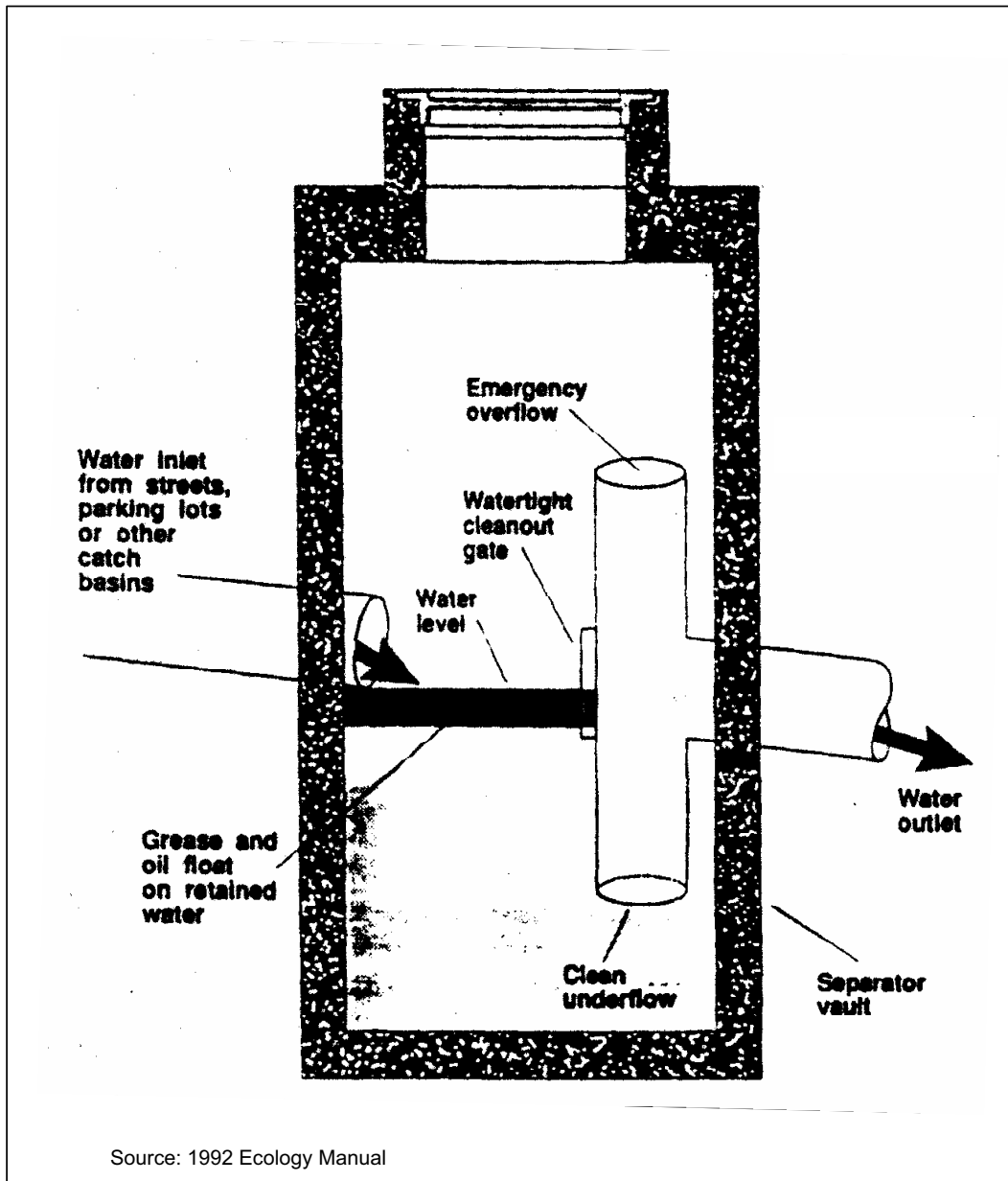


Figure 5 - 34. Coalescing Plate Separator



*Figure 5 - 35. Spill Control Separator (not for oil treatment)*

## 12.4 Site Suitability

Consider the following site characteristics:

- Sufficient land area
- Adequate TSS control or pretreatment capability
- Compliance with environmental objectives
- Adequate influent flow attenuation and/or bypass capability
- Sufficient access for operation and maintenance (O & M)

## 12.5 Design Criteria

### 12.5.1 General Considerations

The following are design criteria applicable to API and CP oil/water separators:

- If practicable, determine oil/grease (or TPH) and TSS concentrations, lowest temperature, pH, empirical oil rise rates in the runoff, and the viscosity and specific gravity of the oil. Also determine whether the oil is emulsified or dissolved. (*Washington State Department of Ecology, 2005*) Do not use oil/water separators for the removal of dissolved or emulsified oils such as coolants, soluble lubricants, glycols, and alcohols.
- Locate the separator offline and bypass the incremental portion of flows that exceed the offline 15-minute water quality design flow rate multiplied by 3.5. If it is necessary to locate the separator online, try to minimize the size of the area needing oil control, and use the online water quality design flow rate multiplied by 2.0.
- The separator shall be installed upstream of any other stormwater treatment facility.
- The separator shall be installed upstream of any pumps to prevent oil from emulsifying.
- Separators may be installed upstream or downstream of flow control facilities.
- Separator vaults shall be watertight. Pipes entering and exiting a vault below the water quality design water surface shall be sealed using a non-porous, non-shrinking vault.
- Separator vaults shall have a shutoff mechanism on the outlet pipe to prevent oil discharges during maintenance and to provide emergency shutoff capability in the event of a spill.
- Include a submerged inlet pipe with a down-turned elbow in the first bay at least two feet from the bottom. The outlet pipe shall be a Tee, sized to pass the design peak flow and placed at least 12 inches below the water surface.
- Use absorbents in the afterbay as needed.
- Use only storm drain pipes or impervious conveyances for routing oil contaminated stormwater to the oil and water separator.
- Specify appropriate performance tests after installation and shakedown, and/or certification by a professional engineer that the separator is functioning in accordance with design objectives. Expedient corrective actions must be taken if it is determined that the separator is not achieving acceptable performance levels.
- Add pretreatment for TSS that could clog the separator, or otherwise impair the long-term effectiveness of the separator.

### 12.5.2 Criteria for Baffles

- Oil retaining baffles (top baffles) shall be located at least 1/4 of the total separator length from the outlet and shall extend down at least 50% of the water depth and at least 1 foot from the separator bottom.
- Baffle height to water depth ratios shall be 0.85 for top baffles and 0.15 for bottom baffles.

### 12.5.3 Maintenance

Per Minimum Requirement #9, an operation and maintenance plan shall be prepared for all stormwater management facilities. See Volume 1, Appendix C, Maintenance Checklist #17 and #18 for specific maintenance requirements for oil water separators. Maintenance shall be a basic consideration in design and cost-determination of the stormwater management facility.

Any standing water removed during maintenance operation must be disposed of in a City approved manner. See the dewatering requirements in Volume 4, Appendix D of this manual. Pretreatment may be necessary. Solids must be disposed of in accordance with state and local waste regulations.

Facilities shall be designed and constructed such that the facility can be safely and easily inspected by one person and safely and easily maintained. This may require construction of additional inspection ports or access manholes to allow inspection access to be opened by one person.

## **12.6 Oil Water Separator BMPs**

Two BMPs are described in this section:

- BMP T1110 for baffle type separators
- BMP T1111 for coalescing plate separators

### **12.6.1 BMP T1110 API (Baffle type) Separators**

#### **12.6.1.1 Design Criteria**

- API separators shall be divided into three compartments: a forebay, an oil separation cell and an afterbay.
  - The forebay is designed primarily to trap and collect sediment, support plug flow conditions and reduce turbulence.
  - The oil separation cell traps and holds oil as it rises from the water column, and it serves as a secondary sediment collection area.
  - The afterbay provides a relatively oil-free cell before the outlet and provides a secondary oil separation area.
- The length of the forebay shall be approximately 1/3 to 1/2 the length of the vault. In addition, the surface area of the forebay must be at least 20 square feet per 10,000 square feet of impervious area draining to the separator.
- A removable flow-spreading baffle, extending from the surface to a depth of up to 1/2 the vault depth (D) is recommended to spread flows. Design guidelines for level spreaders are provided in Section 5.2 of this volume.
- A removable baffle (sediment-retaining baffle) shall be a minimum of 24 inches and located at least 1 foot from the oil-retaining baffle. A “window-wall” baffle may be used, but the area of the window opening must be at least three times greater than the area of the inflow pipe.
- A removable oil retaining baffle shall be provided and located approximately 1/4 L from the outlet wall, or a minimum of 8 feet, whichever is greater (the 8-foot minimum is for maintenance purposes). The oil-retaining baffle shall extend from the elevation of the water surface to a depth of at least 50 percent of the design water depth. Various configurations are possible, but the baffle shall be designed to minimize turbulence and entrainment of sediment.
- Baffles may be fixed rather than removable if additional entry ports and ladders are provided so that both sides of the baffle are accessible to maintenance crews.
- Baffle separator vaults shall have a minimum length-to-width ratio of 5:1.

- The design water depth (D) shall be no deeper than 8 feet unless approved by Environmental Services.
- Baffle separator vaults shall have a design water depth-to-width ratio of between 0.3 and 0.5.

### 12.6.1.2 Sizing Criteria

- Determine the oil rise rate,  $V_t$ , in cm/sec, using Stokes' Law, or empirical determination, or 0.033 ft./min. for 60 $\mu$  (micron) oil droplet size. The application of Stokes' Law to site-based oil droplet sizes and densities, or empirical rise rate determinations recognizes the need to consider actual site conditions. In those cases the design basis would not be the 60 micron droplet size and the 0.033 ft/min. rise rate.

Stokes Law equation for rise rate,  $V_t$  (cm/sec):

$$V_t = [(g)(\rho_w - \rho_o)(d^2)] / [(18*\mu_w)]$$

Where:

$V_t$  = the rise rate of the oil droplet (cm/s or ft/sec)  
 $g$  = acceleration due to gravity (cm/s<sup>2</sup> or ft/s<sup>2</sup>)  
 $\rho_w$  = density of water at the design temperature (g/cm<sup>3</sup> or lbm/ft<sup>3</sup>)  
 $\rho_o$  = density of oil at the design temperature (g/cm<sup>3</sup> or lbm/ft<sup>3</sup>)  
 $d$  = oil droplet diameter (cm or ft)  
 $\mu_w$  = absolute viscosity of the water (g/cm·s or lbm/ft·s)

Use:

oil droplet diameter,  $D=60$  microns (0.006 cm)  
 $\rho_w = 0.999$  gm/cc. at 32° F  
 $\rho_o$ : Select conservatively high oil density,  
 For example, if diesel oil @  $\rho_o = 0.85$  gm/cc and motor oil @  $\rho_o = 0.90$  can be present  
 then use  $\rho_o = 0.90$  gm/cc  
 $\eta_w = 0.017921$  poise, gm/cm-sec. at  $T_w = 32$  °F

Use the following separator dimension criteria:

- Separator water depth,  $d \geq 3 \leq 8$  feet (to minimize turbulence)
- Separator width, 6-20 feet
- Depth/width (d/w) of 0.3-0.5

### **For Stormwater Inflow from Drainages under 2 Acres**

Ecology modified the API criteria for treating stormwater runoff from small drainage areas (fueling stations, commercial parking lots, etc.) by using the design hydraulic horizontal velocity,  $V_h$ , for the design  $V_h/V_t$  ratio rather than the API minimum of  $V_h/V_t = 15$ . The API criteria appear applicable for greater than two acres of impervious drainage area.

The following is the sizing procedure using modified API criteria:

1. Determine  $V_t$  and select depth and width of the separator section based on above criteria.



2. Calculate the minimum residence time ( $t_m$ ) of the separator at depth  $d$ :

$$t_m = d/V_t$$

3. Calculate the horizontal velocity of the bulk fluid,  $V_h$ , vertical cross-sectional area,  $A_v$ , and actual design  $V_h/V_t$ .

$$V_h = Q/dw = Q/A_v \text{ (} V_h \text{ maximum at } < 2.0 \text{ ft/min.)}$$

$Q = (3.5)$  (offline 15 minute water quality design flow rate in  $\text{ft}^3/\text{min}$  determined by WWHM, at minimum residence time,  $t_m$ ) \*If an online facility is required  $Q=(2.0)$ (online 15 minute water quality design flowrate in  $\text{ft}^3/\text{min}$  determined by WWHM at minimum residence time,  $t_m$ )

At  $V_h/V_t$  determine  $F$ , turbulence and short-circuiting factor API  $F$  factors range from 1.28-1.74 (see Appendix C).

4. Calculate the minimum length of the separator section,  $l(s)$ , using:

$$l(s) = FQt_m/wd = F(V_h/V_t)d$$

$$l(t) = l(f) + l(s) + l(a)$$

$$l(t) = l(t)/3 + l(s) + l(t)/4$$

Where:

$l(t)$  = total length of 3 bays

$l(f)$  = length of forebay

$l(a)$  = length of afterbay

5. Calculate  $V = l(s)wd = FQt_m$ , and  $A_h = wl(s)$

$V$  = minimum hydraulic design volume

$A_h$  = minimum horizontal area of the separator

**For Stormwater Inflow from Drainages > 2 Acres:**

Use  $V_h = 15 V_t$  and  $d = (Q/2V_h)^{1/2}$  (with  $d/w = 0.5$ ) and repeat above calculations 3- 5.

## **12.6.2 BMP T1111 Coalescing Plate (CP) Separators**

### **12.6.2.1 Design Criteria**

- Coalescing plate separators shall be divided by baffles or berms into three compartments: a forebay, an oil separation cell which houses the plate pack, and an afterbay. The forebay controls turbulence and traps and collects debris. The oil separation cell captures and holds oil. The afterbay provides a relatively oil-free exit cell before the outlet.
- The length of the forebay shall be a minimum of  $\frac{1}{3}$  the length of the vault, L (though  $\frac{1}{2}$  L is recommended). In addition, it is recommended that the surface area of the forebay be at least 20 square feet per 10,000 square feet of tributary impervious area draining to the separator. In lieu of an attached forebay, a separate grit chamber, sized to be at least 20 square feet per 10,000 square feet of tributary impervious area, may precede the oil/water separator.
- An oil-retaining baffle shall be provided. For large units, a baffle position of  $0.25$  L from the outlet wall is recommended. The oil-retaining baffle shall extend from the water surface to a depth of at least 50 percent of the design water depth. Various configurations are possible, but the baffle shall be designed to minimize turbulence and entrainment of sediment.
- A bottom sediment-retaining baffle shall be provided upstream of the plate pack. The minimum height of the sediment-retaining baffle shall be 18 inches. Window walls may be used, but the window opening must be a minimum of three times greater than the area of the inflow pipe.
- It is recommended that entire space between the sides of the plate pack and the vault wall be filled with a solid but lightweight removable material such as a plastic or polyethylene foam to reduce short-circuiting around the plate pack. Rubber flaps are not effective for this purpose.
- The Reynolds Number through the separator bay shall be  $<500$  (laminar flow).
- The separator plates shall meet the following criteria:
  - Plates shall be inclined at  $45^\circ$  to  $60^\circ$  from the horizontal. This range of angles exceeds the angle of repose of many solids and therefore provides more effective droplet separation while minimizing the accumulation of solids on the individual plates.
  - Plates shall have a minimum plate spacing of  $\frac{1}{2}$  inch (perpendicular distance between plates) and have corrugations.
  - Locate plate pack at least 6 inches from the bottom of the separator for sediment storage.
  - Locate plate pack such that there is 12 inches minimum from the top of the plate pack and the bottom of the vault cover.
  - Design plates for ease of removal and cleaning with high-pressure rinse or equivalent.

### 12.6.2.2 Sizing Criteria

Calculate the projected (horizontal) surface area of plates needed using the following equation; based on an oil droplet size of 60 microns:

$$A_h = Q/Vt = [Q] / [(.00386) * ((S_w - S_o)/(\mu_w))]$$

Where

$A_h$  = horizontal surface area of the plates (ft<sup>2</sup>)

$Vt$  = rise rate of the oil droplet (ft/min), 0.033 ft/min for 60 micron oil droplet.

$Q$  = design flowrate (ft<sup>3</sup>/min) The design flowrate is the offline 15-minute water quality design flowrate predicted by WWHM multiplied by 3.5.

$S_w$  = specific gravity of water at the design temperature

$S_o$  = specific gravity of oil at the design temperature

$\mu_w$  = absolute viscosity of the water (poise)

## Chapter 13 Emerging Technologies

### 13.1 Background

Traditional best management practices (BMPs) such as wetponds and filtration swales may not be appropriate in many situations due to size and space restraints or their inability to remove target pollutants. Because of this, the stormwater treatment industry emerged and new stormwater treatment devices are currently in development.

Emerging technologies are those new stormwater treatment devices that are continually being added to the stormwater treatment marketplace. These devices include both permanent and construction site treatment technologies. Many of these devices have not undergone complete performance testing so their performance claims cannot be verified.

### 13.2 Emerging Technology and the City of Tacoma

Proprietary devices are approved on a case-by-case basis.

See the “City of Tacoma Policy Regarding Proprietary Stormwater Treatment Devices” located on the City of Tacoma website for more information on preapproval requests.

### 13.3 Ecology Role in Evaluating Emerging Technologies

To aid local governments in selecting new stormwater treatment technologies Ecology developed the Technology Assessment Protocol – Ecology (TAPE) and Chemical Technology Assessment Protocol Ecology (CTAPE) protocols. These protocols provide manufacturers with guidance on stormwater monitoring so they may verify their performance claims.

As a part of this process Ecology:

- Posts information on emerging technologies at the emerging technologies website: <http://www.ecy.wa.gov/programs/wq/stormwater/newtech/index.html>.
- Participates in all Technical Review Committee (TRC) and Chemical Technical Review Committee (CTRC) activities which include reviewing manufacturer performance data and providing recommendations on use level designations.
- Grants use level designations based on performance and other pertinent data submitted by the manufacturers and vendors.
- Provides oversight and analysis of all submittals to ensure consistency with this manual.

### 13.4 Evaluation of Emerging Technologies

Local governments should consider the following as they make decisions concerning the use of new stormwater treatment technologies in their jurisdiction:

#### ***Remember the Goal:***

The goal of any stormwater management program or BMP is to treat and release stormwater in a manner that does not harm beneficial uses.

#### ***Exercise Reasonable Caution:***

Before allowing a new technology for an application, the local government should review evaluation information based on the TAPE or CTAPE.

An emerging technology cannot be used for new or redevelopment unless this technology has a use level designation. Having a use level designation means that Ecology and the TRC or CTRC reviewed system performance data and believe the technology has the ability to provide the level of treatment claimed by the manufacturer.

To achieve the goals of the Clean Water Act and the Endangered Species Act, local governments may find it necessary to retrofit stormwater pollutant control systems for many existing stormwater discharges. In retrofit situations, the use of any BMP that makes substantial progress toward these goals is a step forward and Ecology encourages this. To the extent practical, the performance of BMPs used in retrofit situations should be evaluated using the TAPE or CTAPE protocols.

### **13.5 Assessing Levels of Development of Emerging Technologies**

Ecology developed use level designations to assess levels of development for emerging technologies. The use level designations are based upon the quantity, quality, and type of performance data. There are three use level designations: pilot use level designation, conditional use level designation, and general use level designation.

#### ***Pilot Use Level Designation (PULD)***

For technologies that have limited performance data, the pilot use level designation allows limited use to enable field testing to be conducted. Pilot use level designations may be given based solely on laboratory performance data. Pilot use level designations apply for a specified time period only. During this time period, the proponent must complete all field testing and submit a technology evaluation report (TER) to Ecology and the TRC. Ecology will limit the number of installations to five during the pilot use level period.

Local governments may allow PULD technologies to be installed if the manufacturer agrees to conduct additional field testing based on the TAPE at all sites to obtain a general use level designation. Local governments covered by a municipal stormwater NPDES permit must notify Ecology in writing when a PULD technology is proposed. The form can be found: <http://www.ecy.wa.gov/programs/wq/stormwater/newtech/PULDNOI.pdf>

#### ***Conditional Use Level Designation (CULD)***

For emerging technologies that have considerable performance data that was not collected per the TAPE protocol, the CULD was established. Conditional use level designations may be given if field data has been collected by a protocol that is reasonably consistent but does not necessarily fully meet the TAPE protocol. The field data must meet the statistical goals set out in the TAPE guidelines (Appendix D). Laboratory data may be used to supplement field data. Technologies that are granted a CULD will be allowed continued use for a specified time period, during which the field testing necessary to obtain a general use level designation (GULD) must be completed and a TER must be submitted to Ecology and the TRC. Ecology will limit the number of installations to ten during the CULD period.

#### ***General Use Level Designation (GULD)***

The general use level designation (GULD) confers a general acceptance for the specified applications (land uses). Technologies with a GULD may be used anywhere in Washington, subject to Ecology conditions.

## **13.6 Examples of Emerging Technologies for Stormwater Treatment and Control**

Go to the Ecology Emerging Technologies website to obtain information on technologies that have obtained a use level designation:

<http://www.ecy.wa.gov/programs/wq/stormwater/newtech/index.html>

## **13.7 Maintenance**

Per Minimum Requirement #9, an operation and maintenance plan shall be prepared for all stormwater management facilities. See Volume 1, Appendix C, Maintenance Checklist #28 for specific maintenance requirements for proprietary devices. Maintenance shall be a basic consideration in design and cost-determination of the stormwater management facility.

The operation and maintenance requirements of proprietary devices are specified on the use level designation.

Any standing water removed during maintenance operation must be disposed of in a City approved manner. See the dewatering requirements in Volume 4 of this manual. Pretreatment may be necessary. Solids must be disposed of in accordance with state and local waste regulations.

Facilities shall be designed and constructed such that the facility can be safely and easily inspected by one person and safely and easily maintained. This may require construction of additional inspection ports or access manholes to allow inspection access to be opened by one person.

**This Page Intentionally Left Blank**

## Appendix A Basic Treatment Receiving Waters

### *All Salt Waterbodies*

#### *Rivers*

Baker	Anderson Creek
Bogachiel	Bear Creek
Cascade	Marblemount
Chehalis	Bunker Creek
Clearwater	Town of Clearwater
Columbia	Canadian Border
Cowlitz	Skate Creek
Elwha	Lake Mills
Green	Howard Hanson Dam
Hoh	South Fork Hoh River
Humptulips	West and East Fork Confluence
Kalama	Italian Creek
Lewis	Swift Reservoir
Muddy	Clear Creek
Nisqually	Alder Lake
Nooksack	Glacier Creek
South Fork Nooksack	Hutchinson Creek
North River	Raymond
Puyallup	Carbon River
Queets	Clearwater River
Quillayute	Bogachiel River
Quinault	Lake Quinault
Sauk	Clear Creek
Satsop	Middle and East Fork Confluence
Skagit	Cascade River
Skokomish	Vance Creek
Skykomish	Beckler River
Snohomish	Snoqualmie River
Snoqualmie	Middle and North Fork Confluence
Sol Duc	Beaver Creek
Stillaguamish	North and South Fork Confluence
North Fork Stillaguamish	Boulder River
South Fork Stillaguamish	Canyon Creek
Suiattle	Darrington
Tilton	Bear Canyon Creek
Toutle	North and South Fork Confluence
North Fork Toutle	Green River
Washougal	Washougal
White	Greenwater River
Wind	Carson
Wynoochee	Wishkah River Road Bridge



***Lakes***

Washington  
Sammamish  
Union  
Whatcom  
Silver

King  
King  
King  
Whatcom  
Cowlitz

## Appendix B Geotextile Specifications

**Table 5 - 18: Geotextile Properties for Underground Drainage**

Geotextile Property Requirements <sup>a</sup>			
Low Survivability			Moderate Survivability
Geotextile Property	Test Method	Woven/Nonwoven	Woven/Nonwoven
Grab Tensile Strength, min. in machine and x-machine direction	ASTM D4632	180 lbs/115 lbs min.	250 lbs/160 lbs min.
Grab Failure Strain, in machine and x-machine direction	ASTM D4632	<50%/>50%	<50%/>50%
Seam Breaking Strength (if seams are present)	ASTM D4632 and ASTM D4884 (adapted for grab test)	160 lbs/100 lbs min.	220 lbs/140 lbs min.
Puncture Resistance	ASTM D6241	370 lbs/220 lbs min.	495 lbs/310 lbs min.
Tear Strength, min. in machine and x-machine direction	ASTM D4533	67 lbs/40 lbs min.	80 lbs/50 lbs min.
Ultraviolet (UV) Radiation stability	ASTM D4355	50% strength retained min., after 500 hrs. in a xenon arc device	50% strength retained min., after 500 hrs. in a xenon arc device

a. All geotextile properties are minimum average roll values (i.e., the test result for any sampled roll in a lot shall meet or exceed the values shown in the table).

**Table 5 - 19: Geotextile for Underground Drainage Filtration Properties**

Geotextile Property Requirements <sup>a</sup>				
Geotextile Property	Test Method	Class A	Class B	Class C
AOS <sup>b</sup>	ASTM D4751	#40 sieve max	#60 sieve max	#80 sieve max
Water Permittivity	ASTM D4491	.5 sec -1 min.	.4 sec -1 min.	.3 sec -1 min.

a. All geotextile properties are minimum average roll values (i.e. the test result for any sampled roll in a lot shall meet or exceed the values shown in the table).

b. Apparent Opening Size (measure of diameter of the pores in the geotextile).

**Table 5 - 20: Geotextile Strength Properties for Impermeable Liner Protection**

Geotextile Property	Test Method	Geotextile Property Requirements <sup>a</sup>
Grab Tensile Strength, min. in machine and x-machine direction	ASTM D4632	250 lbs min.
Grab Failure Strain, in machine and x-machine direction	ASTM D4632	>50%
Seam Breaking Strength (if seams are present)	ASTM D4632 and ASTM D4884 (adapted for grab test)	220 lbs min.
Puncture Resistance	ASTM D4833	125 lbs min.
Tear Strength, min. in machine and x-machine direction	ASTM D4533	90 lbs min.
Ultraviolet (UV) Radiation	ASTM D4355	50% strength stability retained min., after 500 hrs. in a xenon arc device

a. All geotextile properties are minimum average roll values (i.e., the test result for any sampled roll in a lot shall meet or exceed the values shown in the table).

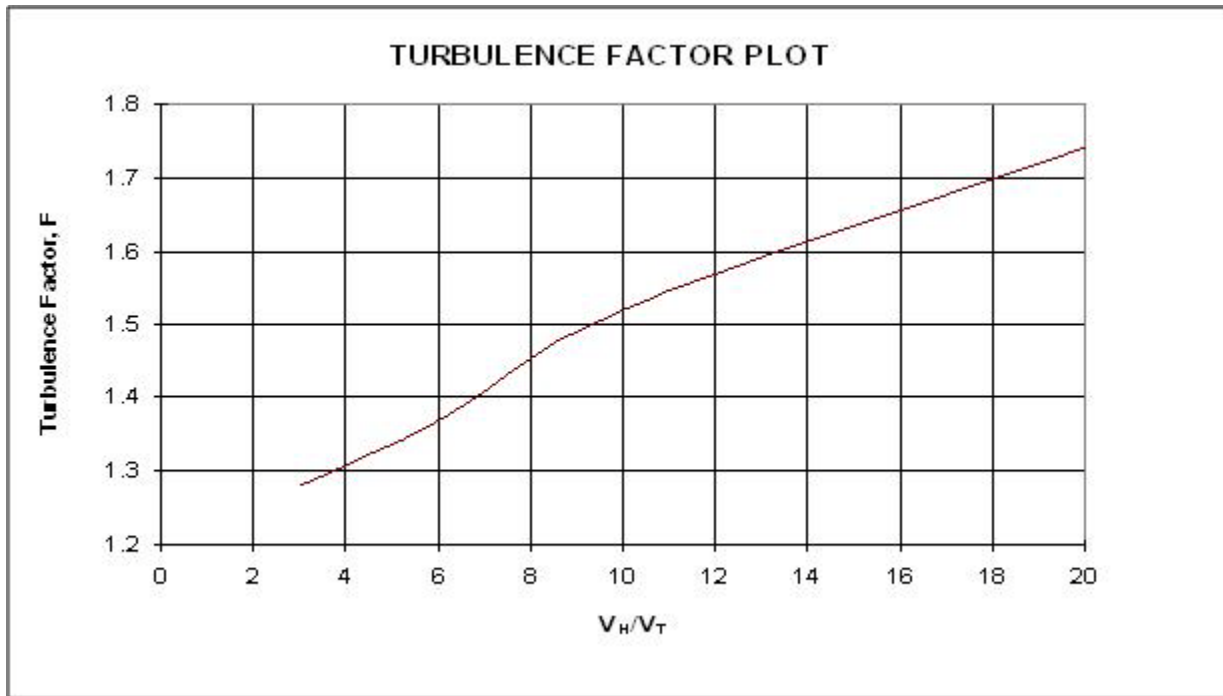
## B.1 Applications

1. For sand filter drain strip between the sand and the drain rock or gravel layers specify Geotextile Properties for Underground Drainage, moderate survivability, Class A, from Table 5 - 18 and Table 5 - 19 in the Geotextile Specifications.
2. For sand filter matting located immediately above the impermeable liner and below the drains, the function of the geotextile is to protect the impermeable liner by acting as a cushion. The specification provided in Table 5 - 20 should be used to specify survivability properties for the liner protection application. Table 5 - 19, Class C should be used for filtration properties. Only nonwoven geotextiles are appropriate for the liner protection application.
3. For an infiltration drain specify Geotextile for Underground Drainage, low survivability, Class C, from Table 5 - 18 and Table 5 - 19 in the Geotextile Specifications.
4. For a sand bed cover a geotextile fabric is placed exposed on top of the sand layer to trap debris brought in by the stormwater and to protect the sand, facilitating easy cleaning of the surface of the sand layer. However, a geotextile is not the best product for this application. A polyethylene or polypropylene geonet would be better. The geonet material should have high UV resistance (90% or more strength retained after 500 hours in the weatherometer, ASTM D4355), and high permittivity (ASTM D4491, 0.8 sec. -1 or more) and percent open area (CWO-22125, 10% or more). Tensile strength should be on the order of 200 lbs grab (ASTM D4632) or more.

Courtesy of Tony Allen, Geotechnical Engineer-WSDOT

Reference for Tables 1 and 2: Section 9-33.2 "Geotextile Properties," 1998 Standard Specifications for Road, Bridge, and Municipal Construction

## Appendix C Turbulence and Short-Circuiting Factor



$V_H/V_T$	Turbulence Factor ( $F_T$ )	$F = 1.2 (F_T)$
20	1.45	1.74
15	1.37	1.64
10	1.27	1.52
6	1.14	1.37
3	1.07	1.28

Figure 5 - 36. Recommended Values of F for Various Values of  $v_H/V_t$

**This Page Intentionally Left Blank**

# **Appendix D South Tacoma Groundwater Protection District Infiltration Policy**



City of Tacoma  
Public Works Department

Memorandum

**To:** Public Works Division Managers, Surface Water Management Staff and City of Tacoma Website

**From:** Richard E. McKinley, Public Works Director *RM*  
Steve Marek, TPCHD Division Director, Environmental Health *SM*

**Subject:** Implementation of Stormwater Infiltration for Pollution Generating Surfaces in the South Tacoma Groundwater Protection District

**Date:** January 21, 2011

The City of Tacoma Public Works Department and Tacoma-Pierce County Health Department (TPCHD) have developed this guidance document to clarify the requirements of TMC Section 13.09 pertaining to the South Tacoma Groundwater Protection District (STGPD), specifically Section 13.09.070 Stormwater Infiltration. The clarified requirements are contained in Table 1 (attached).

**Background:** Tacoma Municipal Code, as it is currently written, prohibits infiltration of pollution generating surfaces in the STGPD except where the Public Works Department and the TPCHD allow an exemption. Table 1 provides the circumstances and requirements for the approval of infiltration facilities for managing pollution generating stormwater runoff in the STGPD.

**Definition:** Per the definition in TMC 13.09.040.KK, a "stormwater infiltration unit" is an impoundment, typically a basin, trench, or bio-infiltration swale whose underlying soil removes pollutants from stormwater. This definition will be interpreted in a broader sense to include pervious pavement and dispersion systems. It is the intent of TMC 13.09.070 to regulate all infiltration facilities in the STGPD.

**Non-Pollution Generating Surfaces:** Infiltration of runoff from non-pollution generating impervious or pervious surfaces is not restricted in the STGPD and will continue to be regulated per the requirements of the Surface Water Management Manual.

**Operation and Maintenance:** It is vital that stormwater treatment facilities be properly maintained and provide appropriate treatment of stormwater prior to infiltration, especially in the STGPD.

Ongoing public education to promote best management practices and required maintenance will be provided to owners of infiltration facilities within the STGPD. Public education will be provided by the TPCHD through their STGPD permit inspections and City of Tacoma Environmental Services through their facility inspections. Coordination for public outreach will be provided with Tacoma Water and Environmental Services customer outreach activities. Ongoing maintenance activities for each facility shall be outlined in the Operation and Maintenance (O&M) Manuals and performed by the owners of the facility.

In addition, each facility will be required to have a Covenant and Easement (C&E) agreement with the City of Tacoma, which will be recorded to the title of the parcel through the Pierce County auditor. The C&E agreement outlines that a facility is present, that the owner is responsible to maintain the facility and that the City of Tacoma may enter the parcel to inspect, and if necessary, maintain the system.

Application: Permit applicants who wish to install stormwater infiltration facilities in the STGPD shall provide design submittals, O&M manuals, Monitoring Plans with associated Quality Assurance Project Plans and C&E agreements for review and approval as outlined in Table 1.

Infiltration within the area of influence of underground contamination or cleanup sites regulated by EPA or another agency shall only be allowed with the approval of the agency with jurisdiction.



Source of stormwater runoff (by Use Intensity)	Permitting and Construction Requirements for Water Quality Treatment	Required Submittal Documents	Operation and Maintenance Responsibility	Monitoring Requirements	Ongoing Inspection Responsibility
<p><b>Low Intensity</b> Residential Street Improvements or residential developments</p>	<p>1. Basic Treatment will be required for all pollution generating surfaces that are infiltrated regardless of:</p> <ul style="list-style-type: none"> <li>the size of the facility,</li> <li>the area contributing to the facility,</li> <li>or if the thresholds of the SWMM are triggered.</li> </ul> <p>2. Stormwater features shall be designed per the requirements in the SWMM. Infiltration facilities shall be reviewed and approved by Environmental Services prior to construction.</p>	<p>1. Permit documents for review</p> <p>2. Covenant and Easement Agreement</p> <p>3. Operations and Maintenance Manual for stormwater facilities</p>	<p>Operation and Maintenance by Owner per requirements listed in the SWMM and O&amp;M Manual.</p>	<p>Monitoring not required.</p>	<p>Inspection by Environmental Services.</p>
<p><b>Medium Intensity</b> Industrial Sites Commercial Sites Multi-family sites High AADT roads (private), or as identified in Step 5 of the Treatment Facility Selection Process for Enhanced Treatment, Chapter 1 of Volume 5, SWMM.</p>	<p>1. Basic and Enhanced Treatment will be required for all pollution generating surfaces that are infiltrated regardless of:</p> <ul style="list-style-type: none"> <li>the size of the facility,</li> <li>the area contributing to the facility,</li> <li>or if the thresholds of the SWMM are triggered.</li> </ul> <p>2. Oil Control will be required for sites meeting the thresholds of the SWMM.</p> <p>3. Monitoring ports shall be installed.</p> <p>4. Health Department to review the overview of the process and site plan.</p> <p>5. When a STGPD Permit is required, the application shall be submitted prior to COT permit issuance.</p> <p>6. A public road would not require a STGPD permit.</p> <p>7. Stormwater features shall be designed per the requirements in the Surface Water Management Manual (SWMM).</p>	<p>1. Overview of process with a site plan to show stormwater features.</p> <p>2. Permit documents for review</p> <p>3. Covenant and Easement Agreement</p> <p>4. Operations and Maintenance Manual for stormwater facilities</p>	<p>Maintenance by Owner per SWMM, O&amp;M Manual and as reviewed and approved by Environmental Services and TPCHD.</p>	<p>Monitoring not required unless specifically requested by TPCHD.</p>	<p>Inspection by Environmental Services and TPCHD, if a STGPD permit is required.</p>
<p>Public Arterial Streets and High public</p>	<p>1. Basic Treatment will be required for all pollution generating surfaces that are infiltrated regardless of:</p>	<p>1. Operation and Maintenance</p>	<p>Maintenance by Sewer Transmission</p>	<p>Monitoring not required unless specifically requested by TPCHD.</p>	<p>Inspection by Environmental Services.</p>

Source of stormwater runoff (by Use Intensity)	Permitting and Construction Requirements for Water Quality Treatment	Required Submittal Documents	Operation and Maintenance Responsibility	Monitoring Requirements	Ongoing Inspection Responsibility
<p>AADT roads</p>	<ul style="list-style-type: none"> <li>• the size of the facility,</li> <li>• the area contributing to the facility, or</li> <li>• or if the thresholds of the SWMM are triggered.</li> </ul> <ol style="list-style-type: none"> <li>2. Oil Removal will be required for sites meeting the thresholds of the SWMM.</li> <li>3. Enhanced Treatment will be required for pollution generating surfaces that are infiltrated when the thresholds of the SWMM are triggered.</li> <li>4. Health Department to review the overview of the process and site plan.</li> <li>5. Monitoring ports shall be installed.</li> <li>6. Stormwater features shall be designed per the requirements in the Surface Water Management Manual (SWMM).</li> </ol>	<p>Manual for stormwater facilities. This information shall be included in the City's Stormwater Detention and Treatment Facility O&amp;M Manual.</p> <ol style="list-style-type: none"> <li>2. Overview of process with a site plan to show stormwater features.</li> </ol>	<p>per the City's Stormwater Detention Treatment Facility O&amp;M Manual.</p>		<p>TPCHD to receive notification of new installations to determine possible need for monitoring.</p>
<p><b>High Intensity</b> Commercial/Industrial Businesses handling, storing, disposing or generating hazardous materials in amounts exceeding the exempted limits identified in TMC 13.09.090. Not including the prohibited uses per TMC 13.09.060.</p>	<ol style="list-style-type: none"> <li>1. Basic Treatment, Enhanced Treatment and Oil Removal will be required for all pollution generating surfaces that are infiltrated regardless of:                             <ul style="list-style-type: none"> <li>• the size of the facility,</li> <li>• the area contributing to the facility,</li> <li>• or if the thresholds of the SWMM are triggered.</li> </ul> </li> <li>2. Monitoring ports shall be installed.</li> <li>3. Health Department to review the overview of the process and site plan.</li> <li>4. STGPD Permit required.</li> <li>5. Stormwater features shall be designed per the requirements in the Surface Water Management Manual (SWMM).</li> </ol>	<ol style="list-style-type: none"> <li>1. Overview of process with a site plan to show stormwater features.</li> <li>2. Permit Construction documents for review</li> <li>3. Covenant and Easement Agreement</li> <li>4. Operations and Maintenance Manual for stormwater facilities</li> <li>5. Quality Assurance Project Plan (QAPP)</li> </ol>	<p>Maintenance by Owner per O&amp;M Manual with STGPD permit and TPCHD review required at permitting phase.</p>	<p>Monitoring by Owner and submitted to the TPCHD and Environmental Services.</p> <ol style="list-style-type: none"> <li>1. May require installation of on-site groundwater monitoring wells with a report of the results from the first storm prior to final certificate of occupancy, or as approved by Environmental Services.</li> <li>2. Will require quarterly monitoring and reporting of stormwater features for the first year.</li> <li>3. May require monitoring and reporting for the life of the project.</li> </ol>	<p>Inspection by Environmental Services and TPCHD. STGPD Permit required.</p>

**This Page Intentionally Left Blank**

## Appendix E Compost Specifications

The following table is a quick guide to compost specification requirements for Best Management Practices that use or may use compost. Refer to the specific BMP for all design and material specifications.

**Table 5 - 21: Mulch Standards and Guidelines**

BMP C120: Temporary and Permanent Seeding											
Compost shall:											
<ul style="list-style-type: none"> <li>• Meet the definition for “composted material” per WAC 173-350-100 and comply with standards in WAC 173-350-220, except the feedstock may contain biosolids or manure feedstocks.</li> <li>• Have no visible water or dust during handling.</li> <li>• Have soil organic matter content of 40% to 65%.</li> <li>• Have a carbon to nitrogen ratio below 25:1. Carbon to nitrogen ratio may be as high as 35:1 for plantings composed entirely of plants native to the Puget Sound Lowlands region.</li> </ul> <p>City of Tacoma TAGRO Potting Soil Mix may be used as an alternative to the compost component.</p>											
BMP C121: Mulching											
Compost shall:											
<ul style="list-style-type: none"> <li>• Meet the definition for “composted material” per WAC 173-350-100 and comply with standards in WAC 173-350-220, except the feedstock may contain biosolids or manure feedstocks.</li> <li>• Be coarse compost meeting the following size gradations (by dry weight) when tested in accordance with the U.S. Composting Council “Test Methods for the Examination of Compost and Composting” (TMECC) Test Method 02.02-B.</li> </ul> <table border="1" data-bbox="425 1247 1172 1440"> <thead> <tr> <th>Sieve Size</th> <th>Minimum Percent Passing</th> </tr> </thead> <tbody> <tr> <td>3”</td> <td>100</td> </tr> <tr> <td>1”</td> <td>90</td> </tr> <tr> <td>3/4”</td> <td>70</td> </tr> <tr> <td>1/4”</td> <td>40</td> </tr> </tbody> </table> <ul style="list-style-type: none"> <li>• Have no visible water or dust during handling</li> <li>• Have soil organic matter content of 40% to 65%.</li> <li>• Have a carbon to nitrogen ratio below 25:1. Carbon to nitrogen ratio may be as high as 35:1 for plantings composed entirely of plants native to the Puget Sound Lowlands region.</li> </ul>		Sieve Size	Minimum Percent Passing	3”	100	1”	90	3/4”	70	1/4”	40
Sieve Size	Minimum Percent Passing										
3”	100										
1”	90										
3/4”	70										
1/4”	40										

**Table 5 - 21: Mulch Standards and Guidelines**

<b>BMP C124: Sodding</b>											
<p>Compost shall:</p> <ul style="list-style-type: none"> <li>• Meet the definition for “composted material” per WAC 173-350-100 and comply with standards in WAC 173-350-220, except the feedstock may contain biosolids or manure feedstocks.</li> <li>• Have no visible water or dust during handling.</li> <li>• Have soil organic matter content of 40% to 65%.</li> <li>• Have a carbon to nitrogen ratio below 25:1. Carbon to nitrogen ratio may be as high as 35:1 for plantings composed entirely of plants native to the Puget Sound Lowlands region.</li> </ul> <p>City of Tacoma TAGRO Potting Soil Mix may be used as an alternative to the compost component.</p>											
<b>BMP C125: Compost</b>											
<p>Compost shall:</p> <ul style="list-style-type: none"> <li>• Meet the definition for “composted material” per WAC 173-350-100 and comply with standards in WAC 173-350-220, except the feedstock may contain biosolids or manure feedstocks.</li> <li>• Be coarse compost meeting the following size gradations (by dry weight) when tested in accordance with the U.S. Composting Council “Test Methods for the Examination of Compost and Composting” (TMECC) Test Method 02.02-B.</li> </ul> <table border="1" style="margin-left: auto; margin-right: auto;"> <thead> <tr> <th style="text-align: center;">Sieve Size</th> <th style="text-align: center;">Minimum Percent Passing</th> </tr> </thead> <tbody> <tr> <td style="text-align: center;">3”</td> <td style="text-align: center;">100</td> </tr> <tr> <td style="text-align: center;">1”</td> <td style="text-align: center;">90</td> </tr> <tr> <td style="text-align: center;">3/4”</td> <td style="text-align: center;">70</td> </tr> <tr> <td style="text-align: center;">1/4”</td> <td style="text-align: center;">40</td> </tr> </tbody> </table> <ul style="list-style-type: none"> <li>• Meet the definition for “composted material” per WAC 173-350-100 and comply with standards in WAC 173-350-220, except the feedstock may contain biosolids or manure feedstocks.</li> <li>• Have no visible water or dust during handling.</li> <li>• Have soil organic matter content of 40% to 65%.</li> <li>• Have a carbon to nitrogen ratio below 25:1. Carbon to nitrogen ratio may be as high as 35:1 for plantings composed entirely of plants native to the Puget Sound Lowlands region.</li> </ul> <p>City of Tacoma TAGRO Potting Soil Mix may be used as an alternative to the compost component.</p>		Sieve Size	Minimum Percent Passing	3”	100	1”	90	3/4”	70	1/4”	40
Sieve Size	Minimum Percent Passing										
3”	100										
1”	90										
3/4”	70										
1/4”	40										

**Table 5 - 21: Mulch Standards and Guidelines**

BMP C126: Topsoiling											
<p>Compost shall:</p> <ul style="list-style-type: none"> <li>• Meet the definition for “composted material” per WAC 173-350-100 and comply with standards in WAC 173-350-220, except the feedstock may contain biosolids or manure feedstocks.</li> <li>• Have no visible water or dust during handling.</li> <li>• Have soil organic matter content of 40% to 65%.</li> <li>• Have a carbon to nitrogen ratio below 25:1. Carbon to nitrogen ratio may be as high as 35:1 for plantings composed entirely of plants native to the Puget Sound Lowlands region.</li> </ul> <p>City of Tacoma TAGRO Potting Soil Mix may be used as an alternative to the compost component.</p>											
BMP C231: Brush Barrier											
<p>Compost shall:</p> <ul style="list-style-type: none"> <li>• Meet the definition for “composted material” per WAC 173-350-100 and comply with standards in WAC 173-350-220, except the feedstock may contain biosolids or manure feedstocks.</li> <li>• Be coarse compost meeting the following size gradations (by dry weight) when tested in accordance with the U.S. Composting Council “Test Methods for the Examination of Compost and Composting” (TMECC) Test Method 02.02-B.</li> </ul> <table border="1" style="margin-left: auto; margin-right: auto;"> <thead> <tr> <th style="text-align: center;">Sieve Size</th> <th style="text-align: center;">Minimum Percent Passing</th> </tr> </thead> <tbody> <tr> <td style="text-align: center;">3”</td> <td style="text-align: center;">100</td> </tr> <tr> <td style="text-align: center;">1”</td> <td style="text-align: center;">90</td> </tr> <tr> <td style="text-align: center;">3/4”</td> <td style="text-align: center;">70</td> </tr> <tr> <td style="text-align: center;">1/4”</td> <td style="text-align: center;">40</td> </tr> </tbody> </table> <ul style="list-style-type: none"> <li>• Have no visible water or dust during handling.</li> <li>• Have soil organic matter content of 40% to 65%.</li> <li>• Have a carbon to nitrogen ratio below 25:1. Carbon to nitrogen ratio may be as high as 35:1 for plantings composed entirely of plants native to the Puget Sound Lowlands region.</li> </ul> <p>City of Tacoma TAGRO Potting Soil Mix may be used as an alternative to the compost component.</p>		Sieve Size	Minimum Percent Passing	3”	100	1”	90	3/4”	70	1/4”	40
Sieve Size	Minimum Percent Passing										
3”	100										
1”	90										
3/4”	70										
1/4”	40										

**Table 5 - 21: Mulch Standards and Guidelines**

BMP C235: Wattles											
Compost shall:											
<ul style="list-style-type: none"> <li>Meet the definition for “composted material” per WAC 173-350-100 and comply with standards in WAC 173-350-220, except the feedstock may contain biosolids or manure feedstocks.</li> <li>Be coarse compost meeting the following size gradations (by dry weight) when tested in accordance with the U.S. Composting Council “Test Methods for the Examination of Compost and Composting” (TMECC) Test Method 02.02-B</li> </ul>											
<table border="1"> <thead> <tr> <th>Sieve Size</th> <th>Minimum Percent Passing</th> </tr> </thead> <tbody> <tr> <td>3”</td> <td>100</td> </tr> <tr> <td>1”</td> <td>90</td> </tr> <tr> <td>3/4”</td> <td>70</td> </tr> <tr> <td>1/4”</td> <td>40</td> </tr> </tbody> </table>		Sieve Size	Minimum Percent Passing	3”	100	1”	90	3/4”	70	1/4”	40
Sieve Size	Minimum Percent Passing										
3”	100										
1”	90										
3/4”	70										
1/4”	40										
<ul style="list-style-type: none"> <li>Have no visible water or dust during handling.</li> <li>Have soil organic matter content of 40% to 65%.</li> <li>Have a carbon to nitrogen ratio below 25:1. Carbon to nitrogen ratio may be as high as 35:1 for plantings composed entirely of plants native to the Puget Sound Lowlands region</li> </ul> <p>City of Tacoma TAGRO Potting Soil Mix may be used as an alternative to the compost component.</p>											
BMP C253: pH Control for High pH Water											
Dispersion though compost amended soils meeting BMP L613 Post-Construction Soil Quality and Depth											
BMP L613 Post-Construction Soil Quality and Depth											
Compost shall:											
<ul style="list-style-type: none"> <li>Meet the definition for “composted material” per WAC 173-350-100 and comply with standards in WAC 173-350-220, except the feedstock may contain biosolids or manure feedstocks.</li> <li>Have no visible water or dust during handling.</li> <li>Have soil organic matter content of 40% to 65%.</li> <li>Have a carbon to nitrogen ratio below 25:1. Carbon to nitrogen ratio may be as high as 35:1 for plantings composed entirely of plants native to the Puget Sound Lowlands region.</li> </ul> <p>City of Tacoma TAGRO Potting Soil Mix may be used as an alternative to the compost component.</p>											

**Table 5 - 21: Mulch Standards and Guidelines**

BMP L601: Rain Gardens (as a component of rain garden oil mix)	
Compost shall:	
<ul style="list-style-type: none"> <li>• Meet the definition of “composted material” in WAC 173-350-100 and complies with testing parameters and other standards in WAC 173-350-220.</li> <li>• Be Fine Compost meeting the following size gradation (by dry weight) when tested in accordance with TMECC test method 02.02-B, “Sample Sieving for Aggregate Size Classification.”</li> </ul>	
Sieve Size	Minimum Percent Passing
2”	100
1”	99
5/8”	90
1/4”	75
BMP L630 Bioretention (compost used as a component of bioretention soil mix)	



**Table 5 - 21: Mulch Standards and Guidelines**

Compost:

- Meets the definition of “composted material” in WAC 173-350-100 and complies with testing parameters and other standards in WAC 173-350-220.
- Produced at a composting facility that is permitted by the jurisdictional health authority. Permitted compost facilities in Washington are included on a list available at: [www.ecy.wa.gov/programs/swfa/organics](http://www.ecy.wa.gov/programs/swfa/organics)
- The compost product must originate from a feedstock that contains a minimum of 65% by volume recycled plant waste comprised of “yard debris,” “crop residues,” and “bulking agents”. The remainder of the feedstock may contain a maximum of 35% by volume “post-consumer food waste”. Biosolids are not allowed. Terms are defined in WAC 173-350-100.
- Stable (low oxygen use and CO2 generation) and mature (capable of supporting plant growth) by tests shown below. This is critical to plant success in a bioretention soil mix.
- Moisture content range: no visible free water or dust produced when handling the material.
- Tested in accordance with U.S. Composting Council “Test Method for the Examination of Compost and Composting” (TMECC), as established in the Composting Council’s “Seal of Testing Assurance” (STA) program. Most Washington compost facilities now use these tests.
- Be fine compost meeting the following size gradation (by dry weight) when tested in accordance with TMECC test method 02.02-B, “Sample Sieving for Aggregate Size Classification.”

Sieve Size	Minimum Percent Passing
2”	100
1”	99
5/8”	90
1/4”	75

- pH between 6.0 and 8.5 (TMECC 04.11-A).
- “Physical contaminants” (as defined in WAC 173-350-100) content less than 1% by weight (TMECC 03.08-A) total, not to exceed 0.25 percent film plastic by dry weight.
- Minimum organic matter content of 40% (TMECC 05.07-A “Loss on Ignition”)
- Soluble salt content less than 4.0 dS/m (mmhos/cm) (TMECC 04.10-A “Electrical Conductivity, 1.5 Slurry Method, Mass Basis”)
- Maturity indicators from a cucumber bioassay (TMEC 05.05-A “Seedling Emergence and Relative Growth”) must be greater than 80% for both emergence and vigor
- Stability of 7 mg CO2-C/g OM/day or below (TMECC 05.08-B “Carbon Dioxide Evolution Rate”)
- Carbon to nitrogen ratio (TMECC 05.02A “Carbon to Nitrogen Ratio” which uses 04.01 “Organic Carbon” and 04.02D “Total Nitrogen by Oxidation”) of less than 25:1. The C:N ratio may be up to 35:1 for planting composed entirely of Puget Sound Lowland native species and up to 40:1 for coarse compost to be used as a surface mulch (not in a soil mix).

**Table 5 - 21: Mulch Standards and Guidelines**

<b>BMP L630 Bioretention (compost used as mulch layer)</b>											
<p>Compost used as the mulch layer in the bioretention facility shall:</p> <ul style="list-style-type: none"> <li>• Meet the definition for “composted material” per WAC 173-350-100 and comply with standards in WAC 173-350-220.</li> <li>• Be coarse compost meeting the following size gradations (by dry weight) when tested in accordance with the U.S. Composting Council “Test Methods for the Examination of Compost and Composting” (TMECC) Test Method 02.02-B.</li> </ul> <table border="1" style="margin-left: auto; margin-right: auto;"> <thead> <tr> <th style="text-align: center;">Sieve Size</th> <th style="text-align: center;">Minimum Percent Passing</th> </tr> </thead> <tbody> <tr> <td style="text-align: center;">3”</td> <td style="text-align: center;">100</td> </tr> <tr> <td style="text-align: center;">1”</td> <td style="text-align: center;">90</td> </tr> <tr> <td style="text-align: center;">3/4”</td> <td style="text-align: center;">70</td> </tr> <tr> <td style="text-align: center;">1/4”</td> <td style="text-align: center;">40</td> </tr> </tbody> </table> <ul style="list-style-type: none"> <li>• Have no visible water or dust during handling.</li> </ul>		Sieve Size	Minimum Percent Passing	3”	100	1”	90	3/4”	70	1/4”	40
Sieve Size	Minimum Percent Passing										
3”	100										
1”	90										
3/4”	70										
1/4”	40										
<b>Volume 3, Section 7.2.2.11 - Detention Ponds</b>											
<p>Compost shall:</p> <ul style="list-style-type: none"> <li>• Meet the definition for “composted material” per WAC 173-350-100 and comply with standards in WAC 173-350-220, except the feedstock may contain biosolids or manure feedstocks.</li> <li>• Have no visible water or dust during handling.</li> <li>• Have soil organic matter content of 40% to 65%.</li> <li>• Have a carbon to nitrogen ratio below 25:1. Carbon to nitrogen ratio may be as high as 35:1 for plantings composed entirely of plants native to the Puget Sound Lowlands region.</li> </ul>											
<b>Volume 5, Section 4.1 - Facility Liners</b>											
<p>Compost shall:</p> <ul style="list-style-type: none"> <li>• Meet the definition for “composted material” per WAC 173-350-100 and comply with standards in WAC 173-350-220, except the feedstock may contain biosolids or manure feedstocks.</li> <li>• Have no visible water or dust during handling.</li> <li>• Have soil organic matter content of 40% to 65%.</li> <li>• Have a carbon to nitrogen ratio below 25:1. Carbon to nitrogen ratio may be as high as 35:1 for plantings composed entirely of plants native to the Puget Sound Lowlands region.</li> </ul>											

**Table 5 - 21: Mulch Standards and Guidelines**

BMP T1010 Basic Biofiltration Swale
<p>Compost shall:</p> <ul style="list-style-type: none"><li>• Meet the definition for “composted material” per WAC 173-350-100 and comply with standards in WAC 173-350-220.</li><li>• Have no visible water or dust during handling.</li><li>• Have soil organic matter content of 40% to 65%.</li><li>• Have a carbon to nitrogen ratio below 25:1. Carbon to nitrogen ratio may be as high as 35:1 for plantings composed entirely of plants native to the Puget Sound Lowlands region.</li></ul>

**Table 5 - 21: Mulch Standards and Guidelines**

BMP T1050: Compost-Amended Vegetated Filter Strip (CAVFS)	
Compost shall meet the specifications below:	
<ul style="list-style-type: none"> <li>Meets the definition of “composted material” in WAC 173-350-100 and complies with testing parameters and other standards in WAC 173-350-220.</li> <li>Produced at a composting facility that is permitted by the jurisdictional health authority. Permitted compost facilities in Washington are included on a list available at: <a href="http://www.ecy.wa.gov/programs/swfa/organics">www.ecy.wa.gov/programs/swfa/organics</a></li> <li>The compost product must originate from a feedstock that contains a minimum of 65% by volume recycled plant waste comprised of “yard debris,” “crop residues,” and “bulking agents”. The remainder of the feedstock may contain a maximum of 35% by volume “post-consumer food waste”. Biosolids are not allowed. Terms are defined in WAC 173-350-100.</li> <li>Stable (low oxygen use and CO2 generation) and mature (capable of supporting plant growth) by tests shown below.</li> <li>Moisture content range: no visible free water or dust produced when handling the material.</li> <li>Tested in accordance with U.S. Composting Council “Test Method for the Examination of Compost and Composting” (TMECC), as established in the Composting Council’s “Seal of Testing Assurance” (STA) program. Most Washington compost facilities now use these tests.</li> <li>Be fine compost meeting the following size gradation (by dry weight) when tested in accordance with TMECC test method 02.02-B, “Sample Sieving for Aggregate Size Classification.”.</li> </ul>	
Sieve Size	Minimum Percent Passing
2”	100
1”	99
5/8”	90
1/4”	75
<ul style="list-style-type: none"> <li>pH between 6.0 and 8.5 (TMECC 04.11-A).</li> <li>“Physical contaminants” (as defined in WAC 173-350-100) content less than 1% by weight (TMECC 03.08-A) total, not to exceed 0.25 percent film plastic by dry weight.</li> <li>Minimum organic matter content of 40% (TMECC 05.07-A “Loss on Ignition”)</li> <li>Soluble salt content less than 4.0 dS/m (mmhos/cm) (TMECC 04.10-A “Electrical Conductivity, 1.5 Slurry Method, Mass Basis”)</li> <li>Maturity indicators from a cucumber bioassay (TMEC 05.05-A “Seedling Emergence and Relative Growth”) must be greater than 80% for both emergence and vigor</li> <li>Stability of 7 mg CO2-C/g OM/day or below (TMECC 05.08-B “Carbon Dioxide Evolution Rate”)</li> <li>Carbon to nitrogen ratio (TMECC 05.02A “Carbon to Nitrogen Ratio” which uses 04.01 “Organic Carbon” and 04.02D “Total Nitrogen by Oxidation”) of less than 25:1. The C:N ratio may be up to 35:1 for planting composed entirely of Puget Sound Lowland native species.</li> </ul>	

**Table 5 - 21: Mulch Standards and Guidelines**

Mulch in Stormwater Treatment BMPs (General)
<p>Compost shall:</p> <ul style="list-style-type: none"><li>• Meet the definition for “composted material” per WAC 173-350-100 and comply with standards in WAC 173-350-220.</li><li>• Have no visible water or dust during handling.</li></ul>

# Volume 6 - Low Impact Development

## Table of Contents

Purpose of this Volume . . . . .	6-1
Content and Organization of this Volume . . . . .	6-1
<b>Chapter 1 General Requirements . . . . .</b>	<b>6-3</b>
1.1 Objectives . . . . .	6-3
1.2 Site Assessment . . . . .	6-3
1.3 Site Planning and Layout . . . . .	6-3
1.4 Retain Native Vegetation . . . . .	6-3
1.5 Minimize Clearing and Grading Impacts . . . . .	6-4
<b>Chapter 2 Low Impact Development Best Management Practices . . . . .</b>	<b>6-5</b>
2.1 Application . . . . .	6-5
2.2 Best Management Practices . . . . .	6-5
2.2.1 Site Design BMPs . . . . .	6-5
2.2.1.1 BMP L620 Preserving Native Vegetation . . . . .	6-5
2.2.1.2 BMP L621 Better Site Design . . . . .	6-6
2.2.2 Structural Low Impact Development BMPS . . . . .	6-7
2.2.2.1 BMP L601 Rain Gardens . . . . .	6-7
2.2.2.2 BMP L630 Bioretention . . . . .	6-14
2.2.2.3 BMP L631 Vegetated Rooftops (Green Roofs) . . . . .	6-29
2.2.2.4 BMP L632 Rainwater Harvesting . . . . .	6-30
2.2.2.5 BMP L633 Permeable Pavements . . . . .	6-30
2.2.2.6 BMP L634 Minimal Excavation Foundations . . . . .	6-39
2.2.2.7 BMP L635 Reverse Slope Sidewalks . . . . .	6-40
<b>Appendix A Recommended Modifications to ASTM D2434 When Measuring Hydraulic Conductivity for Bioretention Soil Mixes . . . . .</b>	<b>6-43</b>
<b>Appendix B Green Stormwater Infrastructure Details . . . . .</b>	<b>6-45</b>





# Low Impact Development

## Purpose of this Volume

This volume focuses on the concept of low impact development. Low impact development is a stormwater and land use management strategy that strives to mimic predisturbance hydrologic processes of infiltration, filtration, storage, evaporation and transpiration by emphasizing conservation, use of onsite natural features, site planning, and distributed stormwater management practices that are integrated into a project design.

Low impact development is sometimes considered to be a component of Green Stormwater Infrastructure which is a set of distributed stormwater best management practices that seek to mimic natural systems and deliver multiple community benefits in addition to stormwater management. Green stormwater infrastructure can be used at a wide range of landscape scales in place of more traditional stormwater control elements to support the principles of Low Impact Development. The terms should not be used interchangeably as some elements that are considered green stormwater infrastructure may not be considered low impact development.

This section should be used in conjunction with “Low Impact Development: Technical Guidance Manual for Puget Sound”, which can be found at: <http://www.ecy.wa.gov/programs/wq/stormwater/municipal/LID/Resources.html>

Volume 3 contains BMPs that are also considered low impact development techniques.

## Content and Organization of this Volume

Volume 6 contains two chapters:

- Chapter 1 provides an overview of the general requirements for low impact development.
- Chapter 2 provides detailed information pertaining to Best Management Practices (BMPs) for low impact development.

The City of Tacoma is developing Standard Plans for Green Stormwater Infrastructure Best Management Practices. These standard plans are available in Volume 6, Appendix B of this manual and may be used in conjunction with the design criteria in each BMP when designing projects. As plans are fully developed and incorporated into the City of Tacoma Right-of-Way Design Manual, the plans will be available at [www.govme.org](http://www.govme.org) under the Standards Plan tab.



**Page Intentionally Left Blank**

# Chapter 1 General Requirements

## 1.1 Objectives

The goal of low impact development is to manage stormwater generated from new development and redevelopment on-site so there will be no negative impacts to adjacent or downstream properties and no degradation to ground or surface waters.

The following are objectives for low impact design:

- Minimize the impacts of increased stormwater runoff from new development and redevelopment by maintaining flow frequencies and durations of the site's undisturbed hydrologic condition.
- Retain and/or restore native soils and vegetation to the maximum extent practicable.
- Retain and incorporate natural site features that promote infiltration of stormwater on the developed site.
- Manage stormwater as close to the source as possible.
- Promote groundwater recharge.
- Provide visible sustainable facilities.
- Minimize impervious surfaces.

## 1.2 Site Assessment

Before implementing LID practices it is necessary to perform a site assessment which includes an assessment of both on-site and off-site conditions and features. See Volume 1, Chapter 4 for Stormwater Site Plan requirements, including site assessment. See Chapter 2 of the "Low Impact Development: Technical Guidance Manual for Puget Sound" for more information on steps for performing a site assessment.

## 1.3 Site Planning and Layout

Sites should be configured to reduce impervious surfaces and utilize natural drainage features. Chapter 3 of the "Low Impact Development: Technical Guidance Manual for Puget Sound" contains information and techniques for site planning.

## 1.4 Retain Native Vegetation

Retain native vegetation to the maximum extent practicable in order to:

- Reduce total impervious surface coverage
- Provide infiltration areas for overland flows generated in adjacent developed portions of the project
- Maintain the natural hydrology of the site.

See BMP L620 in Chapter 2 of this volume, Tree Retention and Transplanting BMPs in Volume 3, Chapter 5, and Chapter 4 of "Low Impact Development: Technical Guidance Manual for Puget Sound" for techniques on retaining native vegetation and trees.

## **1.5 Minimize Clearing and Grading Impacts**

- Conduct a soils analysis prior to clearing and grading to identify predevelopment soil types and infiltration capabilities.
- Keep grading to a minimum by incorporating natural topography.
- Always use appropriate erosion and sediment control techniques when clearing and grading. See Volume 2 of this manual for erosion and sediment control measures.
- Utilize techniques from Chapter 5 of “Low Impact Development: Technical Guidance Manual for Puget Sound”.

## **Chapter 2 Low Impact Development Best Management Practices**

This Chapter presents the methods for analysis and design of on-site stormwater management Best Management Practices (BMPs). Design procedures and requirements for stormwater management BMPs meeting Minimum Requirement #7, Flow Control, are contained in Volume 3.

### **2.1 Application**

Low impact development techniques should be used at every site when feasible. Using low impact development techniques may eliminate the need to install more costly flow control or water quality devices. When utilized in accordance with this manual, most low impact development techniques provide flow credits. Flow credits only apply to flow control thresholds. Flow credits do not apply to water quality thresholds.

### **2.2 Best Management Practices**

The following Low Impact Development BMPs are discussed in this Chapter:

#### ***Site Design BMPs***

- BMP L620 Preserving Natural Vegetation
- BMP L621 Better Site Design

#### ***Structural Low Impact Development BMPs***

- BMP L601 Rain Gardens
- BMP L630 Bioretention Areas
- BMP L631 Vegetated Rooftops
- BMP L632 Rainfall Re-use
- BMP L633 Alternate Paving Systems
- BMP L634 Minimal Excavation Foundations
- BMP L635 Reverse Slope Sidewalks

Infiltration, dispersion, soil quality and tree retention BMPs can be found in Volume 3, Volume 5 and Volume 6.

#### **2.2.1 Site Design BMPs**

##### **2.2.1.1 BMP L620 Preserving Native Vegetation**

###### ***Purpose***

Preserving native vegetation on-site to the maximum extent practicable will minimize the impacts of development on stormwater runoff.

### ***Applications and Limitations***

On lots that are one acre or greater, preservation of 65 percent or more of the site in natural vegetation will allow the use of full dispersion techniques presented in BMP L614 (Volume 3, Section 3.3). Sites that can fully disperse are not required to provide runoff treatment or flow control facilities.

### ***Design Criteria***

- Situate the preserved area to maximize the preservation of wetlands, and to buffer stream corridors and minimize clearing of existing forest.
- Place the preserved area in a separate tract or protect through recorded easements for individual lots.
- If feasible, locate the preserved area downslope from the building sites, since flow control and water quality are enhanced by flow dispersion through duff, undisturbed soils, and native vegetation.
- Show the preserved area on all property maps and clearly mark the area during clearing and construction on the site.

### ***Maintenance***

- Do not remove vegetation and trees from undisturbed areas, except for approved timber harvest activities and the removal of dangerous and diseased trees.

## **2.2.1.2 BMP L621 Better Site Design**

### ***Purpose***

Fundamental hydrological concepts and stormwater management concepts can be applied at the site design phase that are:

- More integrated with natural topography,
- Reinforce the hydrologic cycle,
- More aesthetically pleasing, and
- Often less expensive to build.

### ***Design Criteria***

- **Define Development Envelope and Protected Areas** – The first step in site planning is to define the development envelope. This is done by identifying protected areas, setbacks, easements and other site features, and by consulting applicable local standards and requirements. Site features to be protected may include important existing trees, steep slopes, erosive soils, riparian areas, and wetlands.

By keeping the development envelope compact, environmental impacts can be minimized, construction costs can be reduced, and many of the site's most attractive landscape features can be retained. In some cases, economics or other factors may not allow avoidance of all sensitive areas. In these cases, care can be taken to mitigate the impacts of development through site work and other landscape treatments.

- **Minimize Directly Connected Impervious Areas** – Impervious areas directly connected to the storm drain system are the greatest contributors to urban nonpoint source pollution. Minimize these directly connected impervious areas. This can be done by limiting overall

impervious land coverage or by infiltrating and/or dispersing runoff from these impervious areas.

- **Maximize Permeability** - Within the development envelope, many opportunities are available to maximize the permeability of new construction. These include minimizing impervious areas, paving with permeable materials, clustering buildings, and reducing the land coverage of buildings by smaller footprints. All of these strategies make more land available for infiltration and dispersion through natural vegetation.
- **Build Narrower Streets** - More than any other single element, street design has a powerful impact on stormwater quantity and quality. In residential development, streets and other transportation-related structures typically can comprise between 60 and 70 percent of the total impervious area, and, unlike rooftops, streets are almost always directly connected to the stormwater conveyance system.
- **Maximize Choices for Mobility** - Given the costs of automobile use, both in land area consumed and pollutants generated, maximizing choices for mobility is a basic principle for environmentally responsible site design. By designing residential developments to promote alternatives to automobile use, a primary source of stormwater pollution can be mitigated.
- **Use Drainage as a Design Element** - Unlike conveyance storm drain systems that hide water beneath the surface and work independently of surface topography, a drainage system for stormwater infiltration or dispersion can work with natural land forms and land uses to become a major design element of a site plan.

## **2.2.2 Structural Low Impact Development BMPs**

Low impact development BMPs are structural BMPs that can be used to manage stormwater on-site. Using LID techniques can reduce surface runoff. For each category, basic design criteria is included. The design criteria components in this manual must be used in order to obtain runoff credits.

The guidance provided in “Low Impact Development: Technical Guidance Manual for Puget Sound”, found on the Puget Sound Partnership website: [www.psp.wa.gov](http://www.psp.wa.gov), can also be used in design.

### **2.2.2.1 BMP L601 Rain Gardens**

#### **2.2.2.1.1 Purpose and Definition**

Rain gardens are non-engineered, shallow, landscaped depressions with compost-amended soils and adapted plants. Rain gardens temporarily store stormwater runoff from adjacent areas. Stormwater passes through the amended soil profile and into the native soil beneath. Stormwater that exceeds the rain garden is designed to overflow to an adjacent drainage system. Volume 6, Appendix B of this manual contains several rain garden figures.

#### **2.2.2.1.2 Design Criteria**

##### **2.2.2.1.2.1 Phosphorus-sensitive Waterbodies**

Rain gardens constructed with imported compost material shall not be used within 1/4 mile of phosphorus-sensitive waterbodies if the underlying soils do not meet the soil suitability criteria for treatment (Volume 5, Section 7.3). This restriction does not apply to rain garden construction within 1/4 mile of Wapato Lake. Consult with Environmental Services to determine if a waterbody is considered phosphorus-sensitive.

### **2.2.2.1.2.2 Groundwater Separation**

A minimum of one foot of separation is required between the lowest elevation of the rain garden soil or any underlying gravel infiltration layer and the seasonal high groundwater elevation or other impermeable layer.

### **2.2.2.1.2.3 Infeasibility Criteria**

A rain garden is not required if any of the following infeasibility criteria are met. If a project proponent wishes to use a rain garden facility even when not required to based upon the infeasibility criteria, the criteria in this section apply. Environmental Services will review the proposed design and may allow the installation on a case by case basis. See Volume 3 Appendix B to determine if a soils report is required.

These criteria are in addition to setback criteria described in Volume 3, Section 2.3.3.2.

These criteria are in addition to any competing needs criteria (Vol 1, Sec 3.4.5.7).

Setback distances are measured from the bottom edge of the rain garden soil mix.

The following infeasibility criteria require evaluation of site specific conditions and a written recommendation from a Washington state licensed Professional Engineer or Professional Geologist.

- Where professional geotechnical evaluation recommends infiltration not be used do to reasonable concerns about erosion, slope failure, or down gradient flooding.
- Within an area whose groundwater drains into an erosion hazard or landslide hazard area.
- Where infiltrating water would threaten existing below grade basements.
- Where infiltrating water would threaten shoreline structures such as bulkheads.
- Where the only area available for siting would threaten the safety or reliability of preexisting underground utilities, preexisting underground storage tanks, preexisting structures, or preexisting road or parking lot surfaces.

The following criteria can be cited as reasons for a finding of infeasibility without a written recommendation from a licensed professional engineer or licensed professional geologist, though some require site specific evaluation by an appropriate licensed professional.

- Where the only area available for siting does not allow for a safe overflow pathway to the City storm system or a private storm system.
- Where there is lack of usable space onsite for rain garden facilities at redevelopment sites.
- For work within the public right of way, where there is insufficient space.
- Where they are not compatible with surrounding drainage system (e.g., project drains to an existing stormwater system whose elevation precludes proper connection to a rain garden).
- Where land for the rain garden is within an area designated as an erosion hazard or landslide hazard.
- Where the site cannot be reasonably designed to locate rain gardens on slopes less than 8%.
- For properties with known soil or groundwater contamination:
  - Within 100 feet of an area known to have deep soil contamination;

- Where groundwater modeling indicates infiltration will likely increase or change the direction of the migration of pollutants in the groundwater;
- Wherever surface soils can be found to be contaminated unless those soils are removed within 10 horizontal feet from the infiltration area;
- Any area where these facilities are prohibited by an approved cleanup plan under the state Model Toxics Control Act or Federal Superfund Law, or an environmental covenant under Chapter 64.70 RCW.
- Within 100 feet of a closed or active landfill.
- Within 100 feet of a drinking water well, or a spring used for drinking water supply.
- Within 10 feet of small on-site sewage disposal drainfield, including reserve areas, and grey water reuse systems. For setbacks from a “large on-site sewage disposal system”, see WAC Chapter 246-272B.
- Within 10 feet of an underground storage tank and connecting underground pipes when the capacity of the tank and pipe system is 1100 gallons or less. (As used in this criteria, an underground storage tank means any tank used to store petroleum products, chemicals, or liquid hazardous wastes of which 10% or more of the storage volume (including volume in the connecting piping system) is beneath the ground surface.)
- Within 100 feet of an underground storage tank and connecting underground pipes when the capacity of the tank and pipe system is greater than 1100 gallons.
- Where the field testing indicates potential rain gardens sites have a measured native soil saturated hydraulic conductivity less than 0.30 inches per hour. If the measured native soil infiltration rate is less than 0.30 in/hour, this option should not be used to meet the requirements of MR#5. Soils testing shall comply with Volume 6, Section 6.5.2 – Small Scale PIT Test.

#### **2.2.2.1.2.4 Other Site Suitability Factors**

The following factors should be considered when siting the rain garden facility.

- *Utility conflicts:* See Volume 3, Chapter 10 for utility separation requirements.
- *Transportation safety:* The design configuration and selected plant types should provide adequate sight distances, clear zones, and appropriate setbacks for roadway applications in accordance with City of Tacoma Design Standards.
- *Impacts of surrounding activities:* Human activity influences the location of the facility in the development. For example, locate rain gardens away from traveled areas on individual lots to prevent soil compaction and damage to vegetation or provide elevated or bermed pathways in areas where foot traffic is inevitable. Provide barriers, such as wheel stops, to restrict vehicle access in roadside applications.
- *Visual buffering:* Rain gardens can be used to buffer structures from roads, enhance privacy among residences, and for an aesthetic site feature.

#### **2.2.2.1.2.5 Flow Entrance/Presettling**

- Use one of the following types of flow entrances (other alternatives may be considered on a case-by-case basis):
  - Dispersed across a landscaped area.
  - Dispersed through an open swale with plants and decorative rock. For slopes greater than 2%, add rock check dams every 5 to 10 feet to slow water flow.



- Pipe flow entrance.

Place a rock pad where stormwater enters the rain garden from a swale or pipe. It is recommended to use washed round rock that is a minimum of 2 inches in diameter. Rock pad should be 4” thick and 2 feet wide and extend 2 feet.

Avoid the use of angular rock or quarry spalls as sediment removal is difficult.

- Environmental Services may require flow dispersion for rain gardens depending upon type of inlet design and size of the facility.
- Do not place plants directly in the entrance flowpath as they can restrict or concentrate flows.
- Install flow diversion and erosion control measures to protect the rain garden from sedimentation until the upstream area is stabilized.
- Based upon project site characteristics, Environmental Services may require a presettling facility per Volume 5.

**2.2.2.1.2.6 Cell Ponding Area**

- The ponding depth shall be 6 inches, minimum and 18” maximum.
- See section 2.2.2.1.3 for rain garden sizing and geometry.
- The minimum freeboard measured from the maximum ponding water surface elevation to the top of the facility shall be 2” for drainage areas less than 1,000 square feet and 6” for drainage areas 1,000 square feet or greater.
- If berming is used to achieve the minimum top elevation, maximum slope on berm shall be 2H:1V, and minimum top width of design berm shall be 1 foot. Berm shall be a material which is water tight. Imported soil may be necessary to ensure berm does not fail. Berm shall be tightly packed during construction.

**2.2.2.1.2.7 Overflow**

- Provide an overflow pathway lined with a 4” thick washed rock pad. Washed rock shall be a minimum of 2 inches in diameter. Extend overflow 4 feet past rain garden edge.
- Overflow shall not be directed to structures, neighboring properties, or over sidewalks.
- Overflow shall not cause damage to downstream properties or receiving waters.

**2.2.2.1.2.8 Rain Garden Soil Mix**

- Minimum depth of rain garden mix shall be 12 inches.
- The compost component shall:
  - Meet the definition of “composted material” in WAC 173-350-100 and comply with testing parameters and other standards in WAC 173-350-220.
  - Be Fine Compost meeting the following size gradation (by dry weight) when tested in accordance with TMECC test method 02.02-B, “Sample Sieving for Aggregate Size Classification.”

Sieve Size	Minimum Percent Passing
2”	100
1”	99
5/8”	90

1/4"	75
------	----

- Compost specifications are also contained in Volume 5, Appendix E.
- Obtain a rain garden soil mix by one of the following methods.
  - Method 1: Excavate and replace existing soil with a rain garden soil mix.
    - Use this method if existing soils are poor quality.
      - If clay content is greater than 5%.
      - In gravel soils as plant growth will be inhibited.

A rain garden soil mix typically contains about 60% sand content and 40% compost by volume.

- Method 2: Excavate and amend existing soil
  - Use 1/3 compost to every 2/3 of existing soil.
  - Use this method when existing soils are moderately good to good quality soils.
    - Do not use this method if clay content is greater than 5%. Use Method 1.
- Method 3: Amend Soil in Place
  - Use this method if the existing soils are good quality.
    - Do not use this method if the clay content is greater than 5%. Use Method 1.
    - Use this option only if the infiltration rate is 1 inch per hour or greater.
  - Amend soil by excavating to the ponding depth plus 3 inches. Spread 3 inches of compost and till to depth of 4 to 5 inches to fully incorporate compost component.

### **2.2.2.1.2.9 Planting**

Submit a planting plan showing the type (species), location and size of each plant.

Plants must be tolerant of summer drought, ponding fluctuation, and saturated soil conditions.

Rain gardens have three planting zones. Zone 1 is bottom area of the rain garden, which is frequently wet during the rainy season. Zone 2 includes the side slopes, which occasionally become wet during rain events. Zone 3 includes the area around the perimeter of the rain garden, starting above the top surface of ponding elevation, which has drier soil.

Additional information on planting zones and appropriate plants for each zone can be obtained through the Rain Garden Handbook for Western Washington, available at [www.cityoftacoma.org/raingarden](http://www.cityoftacoma.org/raingarden).

- In general, the following guidelines should be used when considering which plants to use:
  - At least 50% (by quantity) should be evergreen plants. Leaf fall can reduce the function of the facility.

- Do not leave large areas of the soil unplanted/uncovered. Exposed soil can cause erosion and reduce the function of the facility. Plant types can be overlapped (tree canopy can overlap shrubs and groundcover) to reduce the area of exposed soil.
- Provide a variety of plant types with various rooting structures. Plant variety encourages good soil health. Typical plant types used in rain garden construction include:
  - Emergents: Rushes, grasses, and sedges have shallow, fibrous roots that remain close to the soil surface. Planting solely with shallow rooted plants can cause thick root mats to form decreasing the infiltrative ability of the soil.
  - Woody shrubs and trees: Woody shrubs and trees have a mixture of shallow fibrous roots and deeper structural roots that can penetrate deeper into the soil and increase soil porosity over time.
  - Groundcover: Groundcover tends to form dense masses of vegetation low to the ground surface. Low, dense vegetation can be effective at consolidating soil in areas otherwise prone to erosion such as the side slopes of the facility (Zone 2).
  - Herbaceous perennials: Herbaceous perennials do not have woody plant parts and the above ground growth typically dies back in the winter.
- Roots must not damage underground infrastructure.
- Consider adjacent plant communities and avoid potential invasive species.
- Consider aesthetics, rain gardens should blend into surrounding landscapes.
- Irrigation may be required until plants are fully established and in the summer months.

#### **2.2.2.1.2.10 Mulch Layer**

Rain garden facilities should be designed with a mulch layer. Properly selected mulch material reduces weed establishment, regulates soil temperatures and moisture, and adds organic matter to the soil.

- Mulch should be free of weed seeds, soil, roots, and other material that is not trunk or branch wood and bark. Mulch shall not include grass clippings, mineral aggregate, pure bark, or beauty bark. Mulch should be coarse mulch.
- Mulch should be:
  - Wood chip mulch composed of shredded or chipped hardwood or softwood, depth 2-3 inches. Additional rain garden depth will be needed to ensure appropriate ponding and freeboard.
- A dense groundcover can be used as an alternative to mulch although mulch should be used until the dense groundcover is established.

#### **2.2.2.1.3 Sizing and Geometry**

- The top of the ponded surface area below the overflow shall be at least 5% of the total hard surface area draining to it. If lawn/landscaped area will also be draining to the bioretention facility, it is recommended that the top of the ponded surface area below the overflow be increased by 2% of the lawn/landscaped area.

- The maximum side slopes allowed shall be 2:1.

The following table provides the minimum top of ponded surface area, minimum bottom pond area, and minimum top of berm area based upon side slope and contributing area. The applicant shall determine the geometry of their rain garden based upon contributing square footage, minimum sizing criteria and preferred side slope. The applicant shall submit the proposed ponding area, bottom ponding area and top of berm area to Environmental Services for review.

**Table 6 - 1: Rain Garden Sizing and Geometry**

Side Slope	Contributing Area (square feet)	Minimum Top of Ponding Area (square feet)	Minimum Bottom of Ponding Area (square feet)	Minimum Top of Berm Area (square feet)
2:1	800 or less	40	0.11	50
2:1	1400 or less	70	0.13	110
3:1	3000 or less	150	0.06	235

For sites proposing an underdrain, an engineered design will be required. Refer to Volume 6, BMP L630 (Section 2.2.2.2) for sizing guidance.

**2.2.2.1.3.1 Flow Credit**

No flow credits are allowed for rain gardens.

**2.2.2.1.3.2 General Construction Criteria**

- Do not install media or excavate rain garden during soil saturation periods.
- Excavation and soil placement should be done from equipment operating adjacent to the facility – no heavy equipment should be operated in the facility.
- If equipment must be operated within the facility for excavation, use lightweight, low ground pressure equipment and scarify the base to reduce compaction upon completion. Do not use equipment on top of rain garden soil mix.
- Do not use fully excavated rain garden for erosion and sedimentation control during construction.
- Clogged soil and silt shall be removed during excavation to finished bottom grade prior to installing rain garden soil mix.
- Scarify sides and bottom to roughen where equipment may have compacted soil.
- Ensure the rain garden is protected from erosion and sedimentation until all contributory areas are fully stabilized.
- If sedimentation occurs within the rain garden, excavate the area a minimum of 12 inches below final grade to remove sediment and replace media, mulch, and plants as necessary.

**2.2.2.1.4 Maintenance Criteria**

Per Minimum Requirement #9, an operation and maintenance plan shall be prepared for all stormwater management facilities. See Volume 1, Appendix C, Maintenance Checklist #22 for specific maintenance requirements for rain gardens. Maintenance shall be a basic consideration in design and cost-determination of the stormwater management facility.

Any standing water removed during the maintenance operation must be disposed of in a City approved manner. See the dewatering requirements in Volume 4 of this manual. Pretreatment

may be necessary. Solids must be disposed of in accordance with state and local waste regulations.

Facilities shall be designed and constructed such that the facility can be safely and easily inspected by one person and safely and easily maintained. This may require the construction of additional inspection ports or access manholes.

### **2.2.2.2 BMP L630 Bioretention**

#### **2.2.2.2.1 Purpose and Definition**

Bioretention areas are shallow landscaped depressions, with a designed soil mix and plants adapted to the local climate and soil moisture conditions that receive stormwater from a contributing area. Bioretention areas can provide effective removal of many stormwater pollutants, and provide reductions in stormwater runoff quantity and surface runoff flow rates. Bioretention Standard Plans can be found at govme.org under Standard Plans. These Standard Plans can be used for projects in the public ROW and on private property.

In this manual, bioretention areas are categorized as follows:

- Bioretention cells: Shallow depressions with a designed planting soil mix and a variety of plant material, including trees, shrubs, grasses, and/or other herbaceous plants. Bioretention cells may or may not have an underdrain and are not designed as a conveyance system.
- Bioretention swales: Incorporate the same design features as bioretention cells; however, bioretention swales are designed as part of a system that can convey stormwater when maximum ponding depth is exceeded. Bioretention swales have relatively gentle side slopes and ponding depths that are typically 6 to 12 inches.
- Bioretention planters and planter boxes: Designed soil mix and a variety of plant material including trees, shrubs, grasses, and/or other herbaceous plants within a vertical walled container usually constructed from formed concrete, but could include other materials. Planter boxes are completely impervious and include a bottom (must include an underdrain). Planters have an open bottom and allow infiltration to the subgrade. These designs are often used in ultra-urban settings.

**NOTE:** Ecology has approved use of certain patented treatment systems that use specific, high rate media for treatment. Such systems are not considered LID BMPs and are not options for meeting the requirements of Minimum Requirement #5. The Ecology approval is meant to be used for Minimum Requirement #6, where appropriate.

#### **2.2.2.2.2 Phosphorus-sensitive Waterbodies**

Bioretention areas constructed with imported compost material shall not be used within 1/4 mile of phosphorus-sensitive waterbodies if the underlying soils do not meet the soil suitability criteria for treatment (Volume 5, Section 7.3). Facilities with an underdrain that discharge to a phosphorus-sensitive waterbody or to a storm system that discharges to a phosphorus-sensitive waterbody shall not be used within 1/4 mile of phosphorus-sensitive waterbodies. This restriction does not apply to bioretention facility construction within 1/4 mile of Wapato Lake. Consult with Environmental Services to determine if a waterbody is considered phosphorus-sensitive.

#### **2.2.2.2.3 Setback Criteria**

Setback requirements are generally required by the Tacoma Municipal Code, Uniform Building Code, the Tacoma-Pierce County Health Department, or other state regulation. Where a conflict between setbacks occurs, the City shall require compliance with the most stringent of the

setback requirements from the various codes/regulations. The following are the minimum setbacks required per this manual. Additional setbacks may be required by other local, state, or federal agencies. See the individual BMPs for BMP specific setback criteria.

- A least 10 feet from any building structure and at least 5 feet from any other structure or property line unless approved in writing by Environmental Services.
- All facilities shall be a minimum of 50 feet from the top of any steep (greater than 15%) slope. A geotechnical analysis must be prepared addressing impacts to facilities proposed within 50 feet of a steep (greater than 15%) slope. More stringent setbacks may be required based upon other portions of Tacoma Municipal Code.
- At least 10 feet from septic tanks and septic drainfields. Shall not be located upstream of septic systems unless topography or a hydrologic analysis clearly indicates that subsurface flows will not impact the drainfield.
- Environmental Services may require additional setback or analysis for infiltration facilities proposed to be sited within the influence of known contaminated sites or abandoned landfills.

#### **2.2.2.2.4 Site Suitability**

##### **2.2.2.2.4.1 Groundwater Separation**

- A minimum of 3 feet of vertical separation is required between the lowest elevation of the bioretention soil or any underlying gravel infiltration layer and the seasonal high groundwater elevation or other impermeable layer if the area draining to the bioretention facility has 5,000 square feet or more of pollution-generating impervious surface, or 10,000 square feet or more of impervious surface, or  $\frac{3}{4}$  acre or more of pervious surface; and cannot be reasonably broken into smaller amounts.
- A minimum of 1 foot of vertical separation is required between the lowest elevation of the bioretention soil or any underlying gravel infiltration layer and the seasonal high groundwater elevation or other impermeable layer if the area draining to the bioretention facility has less than 5,000 square feet of pollution-generating impervious surface, or less than 10,000 square feet of impervious surface, or less than  $\frac{3}{4}$  acre of pervious surface.

##### **2.2.2.2.4.2 Infeasibility Criteria**

A bioretention facility is not required if any of the following infeasibility criteria are met. If a project proponent wishes to use a bioretention facility even when not required to based upon the infeasibility criteria; Environmental Services will review the proposed design and may allow the installation on a case by case basis. See Volume 3, Appendix B to determine if a soils report is required.

These criteria are in addition to setback criteria described in Section 2.2.2.2.3.

These criteria are in addition to any competing needs criteria (Vol 1, Sec 3.4.5.7).

Setback distances are measures from the bottom edge of the bioretention soil mix.

A site characterization study must be completed in order to determine if the following infeasibility criteria apply.

The following infeasibility criteria require evaluation of site specific conditions and a written recommendation from an appropriate licensed professional (e.g., Professional Engineer, Professional Geologist, Professional Hydrogeologist)

- Where professional geotechnical evaluation recommends infiltration not be used due to reasonable concerns about erosion, slope failure, or down gradient flooding.

- Within an area whose groundwater drains into an erosion hazard or landslide hazard area.
- Where infiltrating water would threaten existing below grade basements.
- Where infiltrating water would threaten shoreline structures such as bulkheads.
- Where the only area available for siting would threaten the safety or reliability of preexisting underground utilities, preexisting underground storage tanks, preexisting structures, or preexisting road or parking lot surfaces.

The following criteria can be cited as reasons for a finding of infeasibility without a written recommendation from a professional engineer though some require site specific evaluation by an appropriate licensed professional.

- Where the only area available for siting does not allow for a safe overflow pathway to the City storm system or a private storm system.
- Where there is lack of usable space onsite for bioretention facilities at redevelopment sites.
- For work within the public right of way, where there is insufficient space.
- Where they are not compatible with surrounding drainage system (e.g., project drains to an existing stormwater system whose elevation precludes proper connection to the bioretention facility).
- Where land for the bioretention facility is within an area designated as an erosion hazard or landslide hazard.
- Where the site cannot be reasonably designed to locate bioretention facilities on slopes less than 8%.
- For properties with known soil or groundwater contamination:
  - Within 100 feet of an area known to have deep soil contamination;
  - Where groundwater modeling indicates infiltration will likely increase or change the direction of the migration of pollutants in the groundwater;
  - Wherever surface soils can be found to be contaminated unless those soils are removed within 10 horizontal feet from the infiltration area;
  - Any area where these facilities are prohibited by an approved cleanup plan under the state Model Toxics Control Act or Federal Superfund Law, or an environmental covenant under Chapter 64.70 RCW.
- Within 100 feet of a closed or active landfill.
- Within 100 feet of a drinking water well, or a spring used for drinking water supply.
- Within 10 feet of small on-site sewage disposal drainfield, including reserve areas, and grey water reuse systems. For setbacks from a “large on-site sewage disposal system”, see WAC Chapter 246-272B.
- Within 10 feet of an underground storage tank and connecting underground pipes when the capacity of the tank and pipe system is 1100 gallons or less. (As used in this criteria, an underground storage tank means any tank used to store petroleum products, chemicals, or liquid hazardous wastes of which 10% or more of the storage volume (including volume in the connecting piping system) is beneath the ground surface.)
- Within 100 feet of an underground storage tank and connecting underground pipes when the capacity of the tank and pipe system is greater than 1100 gallons.

- Where the field testing indicates potential bioretention sites have a measured native soil saturated hydraulic conductivity less than 0.30 inches per hour. If the measured native soil infiltration rate is less than 0.30 in/hour, this option should not be used to meet the requirements of MR#5. In slow draining soils, a bioretention facility with an underdRAIN may be used to treat pollution-generating surfaces to meet Minimum Requirement #6. If the underdrain is elevated within a gravel course, it may provide some flow reduction to help achieve compliance with Minimum Requirement #7.

#### **2.2.2.2.4.3 Other Site Suitability Factors**

The following factors should be considered when siting the bioretention facility.

- *Utility conflicts*: See Volume 3, Chapter 10 for utility separation requirements.
- *Transportation safety*: The design configuration and selected plant types should provide adequate sight distances, clear zones, and appropriate setbacks for roadway applications in accordance with local jurisdiction requirements. The following website contains information for landscaping within the City of Tacoma right of way: <http://cms.cityoftacoma.org/enviro/UrbanForestry/landscape%20standards%20ROW.pdf>. The following website contains information for clearance standards within the City of Tacoma: <http://www.cityoftacoma.org/cms/One.aspx?portalId=169&pageId=12283>
- *Impacts of surrounding activities*: Human activity influences the location of the facility in the development. For example, locate bioretention areas away from traveled areas on individual lots to prevent soil compaction and damage to vegetation or provide elevated or bermed pathways in areas where foot traffic is inevitable. Provide barriers, such as wheel stops, to restrict vehicle access in roadside applications and parking areas.
- *Visual buffering*: Bioretention facilities can be used to buffer structures from roads, enhance privacy among residences, and for an aesthetic site feature.

#### **2.2.2.2.5 Site Characterization**

One of the first steps in siting and designing infiltration facilities is to conduct a characterization study. Information gathered during initial geotechnical investigations can be used for the site characterization. Information gathered during site characterization is used to determine if the infeasibility criteria (Section 2.2.2.2.4.2) apply to the site. See Volume 1, Chapter 4 for site assessment requirements.

##### **2.2.2.2.5.1 Subsurface Characterization**

See Volume 3, Appendix B for soils report requirements.

- Conduct pit/hoLe explorations during the wet season (December 1 through March 31st).
- Subsurface explorations (test holes or test pits) to a depth below the base of the bioretention facility of at least 3 feet.
- Subsurface characterization shall be conducted by a qualified engineer with geotechnical and hydrogeologic experience, or an equivalent professional acceptable to the City, under the seal of a registered Professional Engineer. The design engineer may utilize a team of certified or registered professionals in soil science, hydrogeology, geology, and other related fields.
- The professional can exercise discretion concerning the need for an extent of infiltration rate (saturated hydraulic conductivity) testing. The professional can consider a reduction in the extent of infiltration testing if, in their judgment, information exists confirming that the site is unconsolidated outwash material with high infiltration rates, and there is adequate separation from groundwater.



- On single, smaller commercial properties where one bioretention facility is appropriate, conduct a Small-Scale PIT test per Volume 3, Section 6.5.2.
- On larger commercial and industrial sites, conduct a Small-Scale PIT test every 5000 square feet.
- On multi-lot residential developments, multiple bioretention facilities or a shared facility serving multiple lots may be provided. A Small-Scale PIT test at the location of every bioretention site is required.
- For linear bioretention facilities, a Small-Scale PIT test is required every 200 lineal foot, minimum.
- If the site subsurface characteristics across the site indicate consistent soil characteristics and depths to seasonal high groundwater conditions or hydraulic restriction layer, the number of test locations may be reduced to a frequency recommended by the geotechnical professional.
- If a bioretention area will serve a drainage area exceeding 1 acre, a groundwater mounding analysis may be required.

**2.2.2.2.6 Correction Factors**

The hydraulic saturated conductivity obtained from the PIT test or Soil Grain Size Analysis Method is an initial rate. This initial rate shall be reduced through correction factors that are appropriate for the design situation to produce a design infiltration rate. Use the correction factor from Table 6 - 2 below or alternative values can be proposed based upon the professional judgment of the licensed engineer or site professional. Justification for alternate values must be provided to Environmental Services.

**Table 6 - 2: Measured Hydraulic Saturated Conductivity Rate Reduction Factors**

Issue	Partial Correction Factor
Site Variability and Number of Locations Tested	CF <sub>v</sub> = 0.33 to 1.0

The number of locations tested must be capable of producing a picture of the subsurface conditions that fully represents the conditions throughout the facility site. The partial correction factor used for site variability depends on the level of uncertainty that adverse subsurface conditions may occur. If the range of uncertainty is low - for example, conditions are known to be uniform through previous exploration and site geological factors - one pilot infiltration test (or grain size analysis location) may be adequate to justify a partial correction factor at the high end of the range.

If the level of uncertainty is high, a partial correction factor near the low end of the range may be appropriate. This might be the case where the site conditions are highly variable due to conditions such as a deposit of ancient landslide debris, or buried stream channels. In these cases, even with many explorations and several pilot infiltration tests (or several grain size test locations), the level of uncertainty may still be high.

A partial correction factor near the low end of the range could be assigned where conditions have a more typical variability, but few explorations and only one pilot infiltration test (or one grain size analysis location) is conducted. That is, the number of explorations and tests conducted do not match the degree of site variability anticipated.

## 2.2.2.2.7 Design Criteria

### 2.2.2.2.7.1 Flow Entrance/Presettling

- Flow velocity entering the facility shall be less than 1 ft/sec for the 100-year, 24-hour storm event. If 1 ft/sec cannot be obtained, a designed flow dispersion or energy dissipation device may be required depending on the type of inlet and the size of facility.
- Use the following types of flow entrances (other alternatives may be considered on a case-by-case basis):
  - *Dispersed, low velocity flow across a landscape area:* Landscape areas and vegetated buffer strips slow incoming flows and provide an initial settling of particulates and are the preferred method of delivering flows to the bioretention cell. A minimum 1-inch grade change between the edge of the contributing area and the flow entrance is required.
  - *Dispersed or sheet flow across pavement or gravel and past wheel stops for parking areas.*
    - Curb cuts for roadside, driveway or parking lot areas:
      - Curb cuts should include a rock pad, concrete or other erosion protection material in the channel entrance to dissipate energy.
      - Minimum curb cut width: 12 inches; maximum curb width: 18 inches.
      - Avoid the use of angular rock or quarry spalls and instead use round (river) rock if needed. Removing sediment from angular rock is difficult.
      - Flow entrance should drop 2 to 3 inches from curb line and provide an area for settling and periodic removal of sediment and coarse material before flow dissipates to the remainder of the cell.
    - Curb cuts used for bioretention areas in high use parking lots or roadways require increased level of maintenance due to high coarse particulates and trash accumulation in the flow entrance and associated bypass of flows. The following are methods recommended for areas where heavy trash and coarse particulates are anticipated:
      - Curb cut width: 18 inches.
      - At a minimum, the flow entrance should drop 2 to 3 inches from gutter line into the bioretention area and provide an area for settling and periodic removal of debris.
      - Anticipate relatively more frequent inspection and maintenance for areas with large impervious areas, high traffic loads and larger debris loads.
      - Catch basins or forebays may be necessary at the flow entrance to adequately capture debris and sediment load from large contributing areas and high use areas. Piped flow entrance in this setting can easily clog and catch basins with regular maintenance are necessary to capture coarse and fine debris and sediment.

- *Pipe flow entrance:* Piped entrances should include rock or other erosion protection material in the channel entrance to dissipate energy and disperse flow.
- *Catch basin:* In some locations where road sanding or higher than usual sediment inputs are anticipated, catch basins can be used to settle sediment and release water to the bioretention area through a grate for filtering coarse material.
- *Trench drains:* can be used to cross sidewalks or driveways where a deeper pipe conveyance creates elevation problems. Trench drains tend to clog and may require additional maintenance.
- Do not place plants directly in the entrance flowpath as they can restrict or concentrate flows.
- Install flow diversion and erosion control measures to protect the bioretention area from sedimentation until the upstream area is stabilized.
- If the catchment area exceeds 2,000 square feet, a presettling facility may be required.

#### **2.2.2.2.7.2 Bottom Area and Side Slopes**

Bioretention areas are highly adaptable and can be configured to fit the site by adjusting bottom area and side slope configuration. The following are required maximum and minimum dimensions:

- Maximum planted side slope if total cell depth is greater than 3 feet: 3H:1V. Planted side slopes steeper than 3:1 may be approved if overall facility depth is less than 3 feet. If steeper side slopes are necessary rockeries, concrete walls or soil wraps may be effective design options. Additional safety features may be required where steep side slopes are adjacent to sidewalks, walkways, bike lanes, and parking areas.
- Minimum bottom width for bioretention swales: 1 foot minimum, 2 feet recommended. Carefully consider flow depths and velocities, flow velocity control (check dams) and appropriate vegetation, rock, or mulch to prevent erosion and channelization at bottom widths less than 2 feet.
- Bioretention areas shall have a minimum shoulder of 24 inches between the road edge and beginning of the bioretention side slope where flush curbs are used. Compact shoulder to minimum 90% standard proctor density.
- Bottom area shall be level with no cross slope.

#### **2.2.2.2.7.3 Cell Ponding Area**

- The surface pool drawdown time shall be less than 24 hours.
- Maximum ponding depth shall be 12 inches.
- The minimum freeboard measured from the overflow elevation to the top of the facility shall be 2" for drainage areas less than 1,000 square feet and 6" for drainage areas 1,000 square feet or greater.
- If berming is used to achieve the minimum top elevation, maximum slope on berm shall be 3H:1V, and minimum top width of design berm shall be 1 foot. Soil for berming shall be imported bioretention soil or amended native soil compacted to a minimum of 90% dry density.

#### **2.2.2.2.7.4 Overflow**

- Unless designed for full infiltration of the entire runoff volume, bioretention systems must include an overflow.

- A drain pipe installed at the designed maximum ponding elevation and connected to a downstream BMP or an approved discharge point can be used as the overflow.
- Overflows shall be designed to convey the 100-year recurrence interval flow or maximum flow that can reach the facility if a flow splitter is utilized.
- Overflow channels shall be rock-lined.
- An emergency overflow pathway shall be provided for all facilities to ensure that all potential overflows are directed into the downstream conveyance system or the public right of way.
- See Volume 3, Chapter 11 for additional guidance on rock protection.

**2.2.2.2.7.5 Bioretention Soil Media**

- Minimum depth of bioretention soil mix shall be 18 inches.

**2.2.2.2.7.5.1 Default Bioretention Soil Media**

Projects that use the following bioretention soil mix do not have to test the media for the saturated hydraulic conductivity.

The bioretention soil media (BSM) shall meet the following standards:

- Have a 60-65% mineral aggregate component by volume as specified below and a 35-40% compost component by volume as specified below.
- Have organic matter content of 5-8% by weight.
- Have a cation exchange capacity (CEC)  $\geq 5$  milliequivalents/100 g dry soil. BSM meeting the above specifications do not have to be tested for CEC value; it is assumed the CEC value is met.

The mineral aggregate component shall meet the following standards:

- Have a maximum of 5% fines with an ideal range between 2-4% fines using ASTM D422.
- Be well graded. According to ASTM D 2487-98, well graded sand should have the following gradation coefficients:
  - Coefficient of Uniformity ( $C_u = D_{60}/D_{10}$ ) equal to or greater than 4, and
  - Coefficient of Curve  $C_c = \left( \frac{(D_{30})^2}{D_{60}} \right) \times (D_{10})$  equal to or greater than 1 and less than or equal to 3.
- Meet the gradation presented in Table 6 - 3.

**Table 6 - 3: Bioretention Soil Mix Aggregate Component Gradation**

Aggregate Component (60% by Volume)	
Sieve Size	Percent Passing
3/8"	100
#4	95-100
#10	75-90
#40	25-40
#100	4-10
#200	2-5

Compost used as a component of the default bioretention soil mix (BSM) in bioretention facilities shall meet the specifications below:

- Meets the definition of “composted material” in WAC 173-350-100 and complies with testing parameters and other standards in WAC 173-350-220.
- Produced at a composting facility that is permitted by the jurisdictional health authority. Permitted compost facilities in Washington are included on a list available at: [www.ecy.wa.gov/programs/swfa/organics](http://www.ecy.wa.gov/programs/swfa/organics)
- The compost product must originate from a feedstock that contains a minimum of 65% by volume recycled plant waste comprised of “yard debris,” “crop residues,” and “bulking agents”. The remainder of the feedstock may contain a maximum of 35% by volume “post-consumer food waste”. Biosolids are not allowed. Terms are defined in WAC 173-350-100.
- Stable (low oxygen use and CO2 generation) and mature (capable of supporting plant growth) by tests shown below. This is critical to plant success in a bioretention soil mix.
- Moisture content range: no visible free water or dust produced when handling the material.
- Tested in accordance with U.S. Composting Council “Test Method for the Examination of Compost and Composting” (TMECC), as established in the Composting Council’s “Seal of Testing Assurance” (STA) program. Most Washington compost facilities now use these tests.
- Be fine compost meeting the following size gradation (by dry weight) when tested in accordance with TMECC test method 02.02-B, “Sample Sieving for Aggregate Size Classification.”

Sieve Size	Minimum Percent Passing
2”	100
1”	99
5/8”	90
1/4”	75

- pH between 6.0 and 8.5 (TMECC 04.11-A).
- “Physical contaminants” (as defined in WAC 173-350-100) content less than 1% by weight (TMECC 03.08-A) total, not to exceed 0.25 percent film plastic by dry weight.
- Minimum organic matter content of 40% (TMECC 05.07-A “Loss on Ignition”)
- Soluble salt content less than 4.0 dS/m (mmhos/cm) (TMECC 04.10-A “Electrical Conductivity, 1.5 Slurry Method, Mass Basis”)
- Maturity indicators from a cucumber bioassay (TMECC 05.05-A “Seedling Emergence and Relative Growth”) must be greater than 80% for both emergence and vigor
- Stability of 7 mg CO<sub>2</sub>-C/g OM/day or below (TMECC 05.08-B “Carbon Dioxide Evolution Rate”)
- Carbon to nitrogen ratio (TMECC 05.02A “Carbon to Nitrogen Ratio” which uses 04.01 “Organic Carbon” and 04.02D “Total Nitrogen by Oxidation”) of less than 25:1. The C:N ratio may be up to 35:1 for planting composed entirely of Puget Sound Lowland native species and up to 40:1 for coarse compost to be used as a surface mulch (not in a soil mix).

Compost specifications are also found in Volume 5, Appendix E.

### **2.2.2.2.7.5.2 Custom Bioretention Soil Media**

Projects which prefer to create a custom Bioretention Soil Mix rather than using the default requirements above must demonstrate compliance with the following criteria using the specified test method:

- CEC  $\geq$  5 meq/100 grams of dry soil; USEPA 9081
- pH between 5.5 and 7.0
- 5 - 8 percent organic matter content before and after the saturated hydraulic conductivity test; ASTM D2974(Standard Test Method for Moisture, Ash, and Organic Matter of Peat and Other Organic Soils)
- 2-5 percent fines passing the 200 sieve; TMECC 04.11-A
- Measured (Initial) saturated hydraulic conductivity of less than 12 inches per hour; ASTM D 2434 (Standard Test Method for Permeability of Granular Soils (Constant Head)) at 85% compaction per ASTM D 1557 (Standard Test Methods for Laboratory Compaction Characteristics of Soil Using Modified Effort). Also, use Appendix V-B, Recommended Procedures for ASTM D 2434 When Measuring Hydraulic Conductivity for Bioretention Soil Mixes.
- Design (long-term) saturated hydraulic conductivity of more than 1 inch per hour. Note: Design saturated hydraulic conductivity is determined by applying the appropriate infiltration correction factors as shown in Table 6 - 5.
- If compost is used in creating the custom mix, it must meet all of the specifications listed above for the Default Bioretention Mix, except for the gradation specification. An alternate gradation may be proposed. The applicant is required to submit the alternate gradation specification which shall include similar particle sizes.

### **2.2.2.2.7.6 Filter Fabric**

Do not use filter fabric between the subgrade and the Bioretention Soil Media.

### **2.2.2.2.7.7 Underdrain**

Only install underdrains in bioretention areas if:

- Located near sensitive infrastructure where flooding is likely
- The facility if used for treating stormwater discharge from gas stations or other pollutant hotspots.
- Where a liner is used.
- Where infiltration is not permitted due to site suitability criteria.
- A bioretention facility with elevated underdrain may be used to satisfy Minimum #5 – List #2 provided the following criteria are met (though an underdrain is not required):
  - The estimated initial infiltration rate of the underlying native soils is between 0.3 and 0.6 inches.
  - The invert of the underdrain shall be elevated 6” above the bottom of the aggregate bedding layer.
  - The distance between the bottom of the bioretention soil mix and the crown of the underdrain pipe shall be greater than 6” but less than 12”.
  - The aggregate bedding layer must run the full length and full width of the bottom of the bioretention facility.

- A low permeability liner must not be present.

The underdrain pipe shall meet the following criteria:

- Underdrain pipe diameter will depend on hydraulic capacity required, 4-inch minimum. A minimum 6-inch pipe is required for installations to be maintained by the City of Tacoma.
- Underdrains shall be slotted, thick-walled plastic pipe. The slot opening should be smaller than the smallest aggregate gradation for the gravel filter bed (see underdrain filter bed below) to prevent migration of material into the drain. This configuration allows for pressurized water cleaning and root cutting if necessary. Perforated PVC or flexible slotted HDPE pipe cannot be cleaned with pressurized water or root cutting equipment, are less durable and are not recommended. Wrapping the underdrain pipe in filter fabric increases chances of clogging and is not recommended.
- Slotted subsurface drain PVC per ASTM D1785 SCH 40.
- Slots shall be cut perpendicular to the long axis of the pipe and be 0.04 to 0.069 inches by 1 inch long and be spaced 0.25 inches apart (spaced longitudinally). Slots should be arranged in four rows spaced on 45-degree centers and cover ½ of the circumference of the pipe.
- Underdrains shall be sloped a minimum of 0.5 percent unless otherwise specified by an engineer.
- Provide a 6-inch rigid non-perforated observation pipe or other maintenance access every 250 to 300 feet to provide a clean-out port, as well as an observation well to monitor dewatering rates. Ensure access is placed so that it can be found with full vegetation growth.
- Place underdrain on a bed of mineral aggregate with a minimum thickness of 6 inches and cover with 6” of mineral aggregate to provide a 1-foot minimum depth around the top and sides of the slotted pipe. The following table provides the gradation for the mineral aggregate. All filter media shall be double washed to ensure removal of fines.

**Table 6 - 4: Underdrain sieve sizes**

Sieve Size	Percent Passing
¾ inch	100
US No. 4	28-56
US No. 8	20-50
US No. 50	3-12
US No. 200	0-1

- Underdrains connected directly to a storm drainage structure shall be non-slotted for at least 2 feet from the structure interface.

**2.2.2.2.7.8 Check Dams and Weirs**

Check dams are necessary for reducing flow velocity and potential erosion, as well as increasing detention time and infiltration capability on sloped sites. Typical materials include concrete, wood, rock, compacted dense soil covered with vegetation, and vegetated hedge rows. Design depends on flow control goals, local regulations for structures within road right-of-ways and aesthetics. Optimum spacing is determined by flow control benefit (modeling) in relation to cost

consideration. See the Low Impact Development Technical Guidance Manual for Puget Sound for figures of typical check dams.

#### **2.2.2.2.7.9 UIC Discharge**

Bioretention facilities that infiltrate may be considered Underground Injection Control facilities. Follow UIC regulations as applicable (Chapter 173-218 WAC).

#### **2.2.2.2.7.10 Hydraulic Restriction Layer**

Adjacent roads, foundations or other infrastructure may require that infiltration pathways are restricted to prevent excessive hydrologic loading. Two types of restricting layers can be incorporated into bioretention designs:

- Clay (bentonite) liners are low permeability liners. Where clay liners are used underdrain systems are necessary. See Volume 5, Chapter 4 for guidelines.
- Geomembrane liners completely block infiltration to subgrade soils and are used for groundwater protection when bioretention facilities are installed to filter storm flows from pollutant hotspots or on sidewalls of bioretention areas to restrict lateral flows to roadbeds or other sensitive infrastructure. Where geomembrane liners are used to line the entire facility underdrain systems are necessary. The liner should have a minimum thickness of 30 mils and be ultraviolet (UV) resistant.

#### **2.2.2.2.7.11 Planting**

Submit a planting plan showing the type (species), location and size of each plant.

Plants must be tolerant of summer drought, ponding fluctuation, and saturated soil conditions.

Locate slotted pipe at least 5 feet from tree roots and other utilities.

Bioretention cells have three planting zones. Zone 1 is bottom area of the rain garden, which is frequently wet during the rainy season. Zone 2 includes the side slopes, which occasionally become wet during rain events. Zone 3 includes the area around the perimeter of the bioretention cell, starting above the top surface of ponding elevation, which has drier soil.

Additional information on planting zones and appropriate plants for each zone can be obtained through “Low Impact Development: Technical Guidance Manual for Puget Sound.”

In general, the following guidelines should be used when considering which plants to use:

- At least 50% (by quantity) should be evergreen plants. Leaf fall can reduce the function of the facility.
- Do not leave large areas of the soil unplanted/uncovered. Exposed soil can cause erosion and reduce the function of the facility. Plant types can be overlapped (tree canopy can overlap shrubs and groundcover) to reduce the area of exposed soil.
- Provide a variety of plant types with various rooting structures. Plant variety encourages good soil health. Typical plant types used in bioretention construction include:
  - Emergents: Rushes, grasses, and sedges have shallow, fibrous roots that remain close to the soil surface. Planting solely with shallow rooted plants can cause thick root mats to form decreasing the infiltrative ability of the soil.
  - Woody shrubs and trees: Woody shrubs and trees have a mixture of shallow fibrous roots and deeper structural roots that can penetrate deeper into the soil and increase soil porosity over time.



- Groundcover: Groundcover tends to form dense masses of vegetation low to the ground surface. Low, dense vegetation can be effective at consolidating soil in areas otherwise prone to erosion such as the side slopes of the facility (Zone 2).
- Herbaceous perennials: Herbaceous perennials do not have woody plant parts and the above ground growth typically dies back in the winter.
- Roots must not damage underground infrastructure.
- Consider adjacent plant communities and avoid potential invasive species.
- Consider aesthetics, bioretention facilities should blend into surrounding landscapes.
- Irrigation may be required until plants are fully established and in the summer months.

**2.2.2.2.7.12 Mulch Layer**

Bioretention facilities should be designed with a mulch layer. Properly selected mulch material reduces weed establishment, regulates soil temperatures and moisture, and adds organic matter to soil.

- Mulch should be free of weed seeds, soil, roots, and other material that is not trunk or branch wood and bark. Mulch shall not include grass clippings, mineral aggregate or pure bark.
- Mulch shall be:
  - Coarse compost in the bottom of the facilities, depth 3 inches. Compost shall:
    - Meet the definition for “composted material” per WAC 173-350-100 and comply with standards in WAC 173-350-220.
    - Be coarse compost meeting the following size gradations (by dry weight) when tested in accordance with the U.S. Composting Council “Test Methods for the Examination of Compost and Composting” (TMECC) Test Method 02.02-B.

Sieve Size	Minimum Percent Passing
3”	100
1”	90
3/4”	70
1/4”	40

- Have no visible water or dust during handling.
- Wood chip mulch composed of shredded or chipped hardwood or softwood on side slopes, above ponding elevation, depth 4 inches. Do not use wood chips that may have been contaminated by preservatives, such as construction debris.
- A dense groundcover can be used as an alternative to mulch although mulch shall be required until the dense groundcover is established.

**2.2.2.2.8 Modeling and Sizing**

**For facilities sized to meet Minimum Requirement #5, Onsite Stormwater Management using the list approach:**

The top of the ponded surface area below the overflow shall be at least 5% of the total impervious surface area draining to it. If lawn/landscaped area will also be draining to the

bioretention facility, it is recommended that the top of the ponded surface area below the overflow be increased by 2% of the lawn/landscaped area.

**For facilities sized to meet Minimum Requirement #6, Water Quality:**

Use WWHM and model the facility using the bioretention element. Size the facility to treat or infiltrate the water quality design volume which is 91% of the total runoff volume as predicted by WWHM. Alternatively, size the facility to treat 100% of the water quality design volume. The surface pool drawdown time shall be 24 hours or less.

**For facilities sized to meet Minimum Requirement #7, Flow Control:**

Use WWHM and model the facility using the bioretention element. Size the facility to meet the flow control requirements. The surface pool drawdown time shall be 24 hours or less.

**Table 6 - 5: WWHM Modeling Assumptions for Bioretention**

Variable	Assumptions
Computational Time Step	15 minutes
Inflows to Facility	Surface flow and interflow from drainage area routed to facility
Precipitation and Evaporation applied to Facility	Yes
Bioretention Soil Infiltration Rates	Default Bioretention Soil Media: WWHM assumes a default infiltration rate of 12 inches per hour. Choose the soil layer SMMWW and the appropriate factor of safety below.
	Custom Bioretention Soil Media” Use ASTM D2434 – “Standard Test Method for Permeability of Granular Soils (Constant Head)” with a compaction rate of 85% using ASTM D1557 – “Test Method for Laboratory Compaction Characteristics of Soil Using Modified Effort.” See Appendix A for recommended modifications for ASTM D2434. Enter the derived value in the “View/Edit Soil Types” pull down menu. Model using the appropriate factor of safety below.
Safety Factor for Saturated Hydraulic Conductivity ( $K_{SAT}$ )	Enter a $K_{SAT}$ Safety Factor of 4 if the contributing area to the facility equals or exceeds any of the following: <ul style="list-style-type: none"> <li>• 5,000 square feet of pollution-generating impervious surface;</li> <li>• 10,000 square feet of impervious surface;</li> <li>• <math>\frac{3}{4}</math> acres of lawn and landscape.</li> </ul> If the contributing area is less than all of the above or if the design includes a pretreatment device for solids removal, enter a $K_{SAT}$ Safety Factor of 2.
Bioretention Soil Depths	Minimum of 18 inches
Native Soil Infiltration Rate	Measured infiltration rate. See Volume 3 for more information on infiltration rate determination.
Infiltration Across Wetted Surface Area	Only if sides slopes are 3:1 or flatter

Variable	Assumptions
Overflow	Model as riser outlet structure.
Underdrain	If underdrain is proposed, click underdrain is used box.
Underdrain Aggregate	Use Gravel as the Material Layer for the Underdrain Aggregate Layer. Only the void volume of the aggregate below the underdrain invert and above the bottom of the bioretention facility can be used for flow control benefits.

**2.2.2.2.9 General Construction Criteria:**

- Do not install media or excavate bioretention facility during soil saturation periods.
- Excavation and soil placement should be done from equipment operating adjacent to the facility or by conveyor – no heavy equipment should be operated in the facility.
- If equipment must be operated within the facility, use lightweight, low ground pressure equipment and scarify the base to reduce compaction upon completion.
- Clogged soil and silt shall be removed during excavation to finished bottom grade prior to installing bioretention cell profile.
- Scarify sides and bottom a minimum of 3 inches to roughen before BSM placement.
- Ensure the bioretention facility is protected from erosion and sedimentation until all contributory areas are fully stabilized.
- If sedimentation occurs within the bioretention facility, excavate the area as necessary in minimum 6-inch lifts to remove sediment.
- Subgrade infiltration rates shall be field tested per Vol 6, Sec 2.2.2.2.10 and compared to design rates. Failure to meet or exceed the design infiltration rate will require revised engineering design to verify achievement of treatment and flow control benefits that were estimated in the design.
- Prior to placement of the BSM, the subgrade shall be inspected by the responsible engineer to verify condition.
- Do not mix or place soil if the BSM or subgrade is saturated.
- Place the BSM in horizontal layers not to exceed 12 inches per lift.
- Compact the BSM to a relative compaction of 85% of modified maximum dry density. Compaction can be achieved by boot packing and applying 0.2 inches of water per 1 inch of BSM depth. Water for settling shall be sprayed or sprinkled.
- Do not use bioretention facilities as temporary sediment control facilities. Construction of the bioretention area should not begin until contributing areas are stabilized. Inlets should be blocked until BSM has been placed and bioretention facility has been planted. All inlet protection shall be in place before inlets are unblocked.

**2.2.2.2.10 Verification Testing**

- If using the default bioretention soil media, laboratory analysis for saturated hydraulic conductivity of the bioretention soil media is not required. The applicant shall provide verification of the mineral aggregate gradation, compliance with the compost specifications, and the mix ratio before soil placement.
- If using a custom bioretention soil media, verification of compliance with the minimum design criteria cited above for such custom mixes must be provided. This will require laboratory testing of the material that will be used in the installation. Testing shall be

performed by a Seal of Testing Assurance, AASHTO, ASTM or other standards organization accredited laboratory with current and maintained certification. Samples for testing must be supplied from the BSM that will be placed in the bioretention areas.

- If testing infiltration rates is necessary for post-construction verification, use the Pilot Infiltration Test (PIT) method or a double ring infiltrometer test. If using the PIT method, do not excavate Bioretention Soil Mix (conduct test at level of finished Bioretention Soil Mix elevation), use a maximum of 6 inch ponding depth and conduct test before plants are installed. Environmental Services will determine the need for post construction verification on a case-by-case basis.

#### **2.2.2.2.11 Operation and Maintenance**

- Per Minimum Requirement #9, an operation and maintenance plan shall be prepared for all stormwater management facilities. See Volume 1, Appendix C for specific maintenance requirements for bioretention facilities. Maintenance shall be a basic consideration in design and cost-determination of the stormwater management facility.
- Any standing water removed during maintenance operation must be disposed of in a City approved manner. See the dewatering requirements in Volume 4 of this manual. Pretreatment may be necessary. Solids must be disposed of in accordance with state and local waste regulations.
- Facilities shall be designed and constructed such that the facility can be safely and easily inspected by one person and safely and easily maintained. This may require construction of additional inspection ports or access manholes to allow inspection access to be opened by one person.

#### **2.2.2.3 BMP L631 Vegetated Rooftops (Green Roofs)**

##### **2.2.2.3.1 Purpose and Definition**

A vegetated rooftop, also known as a green roof, is a rooftop that is partially or completely covered with vegetation and a growing medium planted over a waterproofing membrane. The green roof will also contain a root repelling membrane and drainage system.

##### **2.2.2.3.2 Applications and Limitations**

Vegetated rooftops offer a practical method of managing runoff in densely developed urban neighborhoods and can be engineered to achieve specific stormwater runoff control objectives.

##### **2.2.2.3.3 Design Guidelines**

See the “Low Impact Development Technical Guidance for Puget Sound” for design criteria. Figure 6-8 provides a general schematic of a Green Roof Section.

##### **2.2.2.3.4 Flow Credits for Vegetated Roofs**

Modeling in WWHM is required to obtain flow credits. Model the facility using the Green Roof element.

##### **2.2.2.3.5 Maintenance Criteria**

Per Minimum Requirement #9, an operation and maintenance manual shall be prepared for all stormwater management facilities. See Volume 1, Appendix C, Maintenance Checklist #26 for specific maintenance requirements for vegetated roofs. Maintenance shall be a basic consideration in design and cost-determination of the stormwater management facility.

Any standing water removed during the maintenance operation must be disposed of in a City-approved manner. See the dewatering requirements in Volume 4 of this manual. Pretreatment

may be necessary. Solids must be disposed of in accordance with state and local waste regulations.

#### **2.2.2.4 BMP L632 Rainwater Harvesting**

##### **2.2.2.4.1 Purpose and Definition**

Rainwater harvesting systems are designed to collect stormwater and use the collected water.

##### **2.2.2.4.2 Applications and Limitations**

Approval of the water re-use system requires approval of the appropriate state and local agencies as required for any water right.

##### **2.2.2.4.3 Design Guidelines**

- Figure GSI - 010 (see Volume 6, Appendix B) shows a conceptual plan for a vegetated roof section.
- If a rainwater re-use system holds more than 6 inches depth of water, the system should not be easily accessible except for maintenance purposes.
- Design and maintain the system to minimize clogging by leaves and other debris.
- Restrict use to locations with no more than 4 homes/acre when captured water is solely used for outdoor use.

##### **2.2.2.4.4 Flow Credits for Rainwater Harvesting**

The drainage area to the rainfall re-use system does not need to be entered into the runoff model when:

- 100% of the annual average runoff volume (using WWHM) is re-used, or
- Interior uses have a monthly water balance that demonstrates adequate capacity for each month and re-use of all stored water annually.

##### **2.2.2.4.5 Maintenance Criteria**

Per Minimum Requirement #9, an operation and maintenance manual shall be prepared for all stormwater management facilities. See Volume 1, Appendix C, Maintenance Checklist #24 for specific maintenance requirements for cisterns. Maintenance shall be a basic consideration in design and cost-determination of the stormwater management facility.

Any standing water removed during the maintenance operation must be disposed of in a City-approved manner. See the dewatering requirements in Volume 4 of this manual. Pretreatment may be necessary. Solids must be disposed of in accordance with state and local waste regulations.

#### **2.2.2.5 BMP L633 Permeable Pavements**

##### **2.2.2.5.1 Purpose and Definition**

Permeable paving surfaces are an important integrated management practice within the LID approach and can be designed to accommodate pedestrian, bicycle and auto traffic while allowing infiltration, treatment and storage of stormwater.

The general categories of permeable paving systems include:

- Porous hot or warm-mix asphalt pavement is a flexible pavement similar to standard asphalt that uses a bituminous binder to adhere aggregate together. However, the fine

material (sand and finer) is reduced or eliminated and, as a result, voids form between the aggregate in the pavement surface and allow water to infiltrate.

- Pervious Portland cement concrete is a rigid pavement similar to conventional concrete that uses a cementitious material to bind aggregate together. However, the fine aggregate (sand) component is reduced or eliminated in the gradation and, as a result, voids form between the aggregate in the pavement surface and allow water to infiltrate.
- Permeable interlocking concrete pavements (PICP) and aggregate pavers. PICPs are solid, precast, manufactured modular units. The solid pavers are (impervious) high-strength Portland cement concrete manufactured with specialized production equipment. Pavements constructed with these units create joints that are filled with permeable aggregates and installed on an open-graded aggregate bedding course. Aggregate pavers (sometimes called pervious pavers) are a different class of pavers from PICP. These include modular precast paving units made with similar sized aggregates bound together with Portland cement concrete with high-strength epoxy or other adhesives. Like PICP, the joints or openings in the units are filled with open-graded aggregate and placed on an open-graded aggregate bedding course. Aggregate pavers are intended for pedestrian use only.
- Grid systems include those made of concrete or plastic. Concrete units are precast in a manufacturing facility, packaged and shipped to the site for installation. Plastic grids typically are delivered to the site in rolls or sections. The openings in both grid types are filled with topsoil and grass or permeable aggregate. Plastic grid sections connect together and are pinned into a dense-graded base, or are eventually held in place by the grass root structure. Both systems can be installed on an open-graded aggregate base as well as a dense-graded aggregate base.
- The City of Tacoma has developed Standard Plans for permeable pavement sections that can be used for both public and private projects within the City of Tacoma. These plans are available at [govme.org](http://govme.org) under the Standard Plans link.

#### **2.2.2.5.2 Permeable Pavements - Applications and Limitations**

- Permeable paving systems can generally be used where traditional paving surfaces are used. See Volume 6, Appendix B for permeable pavement figures and standard plans.
- Limit run-on to permeable pavement surfaces to the maximum extent practicable. Run-on shall only be allowed from fully stabilized areas.
- Unless the pavement, base course, and subgrade have been designed to accept runoff from adjacent impervious surfaces, slope impervious runoff away from the permeable pavement to the maximum extent practicable. Sheet flow from up-gradient impervious areas is not recommended, but permissible if the permeable pavement area is greater than the impervious pavement area.

#### **2.2.2.5.3 Permeable Pavements – Setbacks**

Setback requirements are generally required by the Tacoma Municipal Code, Uniform Building Code, the Tacoma-Pierce County Health Department, or other state regulation. Where a conflict between setbacks occurs, the City shall require compliance with the most stringent of the setback requirements from the various codes/regulations. The following are the minimum setbacks required per this manual. Additional setbacks may be required by other local, state, or federal agencies. See the individual BMPs for BMP specific setback criteria.

- All facilities shall be a minimum of 50 feet from the top of any steep (greater than 15%) slope. A geotechnical analysis must be prepared addressing impacts to facilities

proposed within 50 feet of a steep (greater than 15%) slope. More stringent setbacks may be required based upon other portions of Tacoma Municipal Code.

- At least 10 feet from septic tank and septic drainfields. Shall not be located upstream of septic systems unless topography or a hydrologic analysis clearly indicates that subsurface flows will not impact the drainfield.
- Environmental Services may require additional setback or analysis for infiltration facilities proposed to be sited within the influence of known contaminated sites or abandoned landfills.

#### **2.2.2.5.4 Permeable Pavements - Groundwater Separation**

- A minimum of 1 foot of vertical separation is required between the bottom of the lowest gravel base course and the seasonal high groundwater elevation or other impermeable layer to ensure that a saturated condition is not created.

#### **2.2.2.5.5 Permeable Pavements - Infeasibility Criteria**

Permeable pavements are not required if any of the following infeasibility criteria are met. If a project proponent wishes to use permeable pavement even when not required to based upon the infeasibility criteria; Environmental Services will review the proposed design and may allow the installation on a case by case basis. See Volume 3, Appendix B to determine if a soils report is required.

These criteria also apply to impervious pavements that would employ stormwater collection from the surface of the impervious pavement with redistribution below the pavement.

These criteria are in addition to setback criteria described in Section 2.2.2.5.3

These criteria are in addition to any competing needs criteria (Vol 1, Sec 3.4.5.7).

Setback distances are measures from the edge of the pavement section.

A site characterization study must be completed in order to determine if the following infeasibility criteria apply.

The following infeasibility criteria require evaluation of site specific conditions and a written recommendation from an appropriate licensed professional (e.g., Professional Engineer, Professional Geologist, Professional Hydrogeologist)

- Where professional geotechnical evaluation recommends infiltration not be used due to reasonable concerns about erosion, slope failure, or down gradient flooding.
- Within an area whose groundwater drains into an erosion hazard or landslide hazard area.
- Where infiltrating and ponded water below new permeable pavement would compromise existing adjacent impervious pavements.
- Where infiltrating and ponded water below new permeable pavement would threaten existing below grade basements.
- Where infiltrating water would threaten shoreline structures such as bulkheads.
- Downslope of steep, erosion prone areas that are likely to erode sediment.
- Where fill soils are used that can become unstable when saturated.
- Excessively steep slopes where water within the aggregate base layer or at the subgrade surface cannot be controlled by detention structures and may cause erosion and

structural failure, or where surface runoff velocities may preclude adequate infiltration at the pavement surface.

- Where permeable pavements cannot provide sufficient strength to support the anticipated loads.
- Where underlying soils are unsuitable for supporting traffic loads when saturated.
- Where installation of permeable pavement would threaten the safety or reliability of preexisting underground utilities, preexisting underground storage tanks, preexisting structures, or preexisting road or parking lot surfaces.

The following criteria can be cited as reasons for a finding of infeasibility without a written recommendation from a professional engineer though some require site specific evaluation by an appropriate licensed professional.

- Within an area designated as an erosion hazard or landslide hazard.
- For properties with known soil or groundwater contamination:
  - Within 100 feet of an area known to have deep soil contamination;
  - Where groundwater modeling indicates infiltration will likely increase or change the direction of the migration of pollutants in the groundwater;
  - Wherever surface soils can be found to be contaminated unless those soils are removed within 10 horizontal feet from the infiltration area;
  - Any area where these facilities are prohibited by an approved cleanup plan under the state Model Toxics Control Act or Federal Superfund Law, or an environmental covenant under Chapter 64.70 RCW.
- Within 100 feet of a closed or active landfill.
- Within 100 feet of a drinking water well, or a spring used for drinking water supply.
- Within 10 feet of small on-site sewage disposal drainfield, including reserve areas, and grey water reuse systems. For setbacks from a “large on-site sewage disposal system”, see WAC Chapter 246-272B.
- Within 10 feet of an underground storage tank and connecting underground pipes, regardless of tank size. As used in this criteria, an underground storage tank means any tank used to store petroleum products, chemicals, or liquid hazardous wastes of which 10% or more of the storage volume (including volume in the connecting piping system) is beneath the ground surface.
- At multi-level parking garages, and over culverts and bridges.
- Where the site cannot reasonably be designed to have a porous asphalt surface at less than 5% slope, or a pervious concrete surface at less than 10% slope, or a permeable interlocking concrete pavement surface at less than 12% slope. Grid systems upper slope limit can range from 6-12%; check with manufacturer.
- Where the native soils below a pollution-generating permeable pavement do not meet the soil suitability criteria for providing treatment. These include:
  - Cation exchange capacity (CEC) of the treatment soil must be  $\geq 5$  milliequivalents CEC/100g dry soil (USEPA Method 9081). Consider empirical testing of soil sorption capacity, if practicable. Ensure that soil CEC is sufficient for expected pollutant loadings, particularly heavy metals. CEC values of  $>5$  meq/100g are expected in loamy sands, according to Rawls, et. al



- Depth of soil used for infiltration treatment must be a minimum of 12 inches
- Organic content shall be a minimum of 1%. Organic content shall be measured on a dry weight basis using ASTM D2974.
- A measured (initial) saturated hydraulic conductivity greater than 9 inches/hour.

If the applicant wishes to use permeable pavement but the criteria above for treatment are not met, they can elect to use a 6" layer of media meeting the soil suitability criteria or a 6" sand layer meeting the sand filter specification (Vol. 5 Ch. 8) to provide treatment.

- Where appropriate field testing indicates soils have a measured native soil saturated hydraulic conductivity less than 0.30 inches per hour. An underdrain may be used in this scenario if desired and properly designed.
- Where the road receives more than very low traffic volumes and more than very low truck traffic. Very low traffic volumes are those with a projected average daily traffic volume of 400 vehicles or less (AASHTO, 2001)(U.S. Department of Transportation, 2013). Very low truck traffic is defined as those areas with less than 2% of ADT as through truck traffic. Very low truck traffic may have up to weekly use by utility trucks (ex. garbage), daily bus use, and multiple daily use by pick-up trucks, mail/parcel delivery trucks, and maintenance vehicles. See RCW 35.78.010, RCW 36.86.070, and RCW 47.05.021. This infeasibility criteria does not extend to sidewalks and other non-traffic bearing surfaces.
- Where replacing existing impervious surfaces unless the existing surface is a non-pollution generating surface over an outwash soil with a saturated hydraulic conductivity of 4 inches/hour or greater.
- At sites defined as "high-use sites".
- In areas with "industrial activity" as identified in 40 CFR 122.26(b)(14).
- Where the risk of concentrated pollutant spills is more likely such as gas stations, truck stops, and industrial chemical storage sites.
- Where routine, heavy applications of sand occur in frequent snow zones to maintain traction during weeks of snow and ice accumulation. Most lowland western Washington areas do not fit this criterion.

#### **2.2.2.5.6 Permeable Pavement Site Characterization**

One of the first steps in siting and designing infiltration facilities is to conduct a characterization study. Information gathered during initial geotechnical investigations can be used for the site characterization. Information gathered during site characterization is used to determine if the infeasibility criteria (Section 2.2.2.5.5) apply to the site. See Volume 1, Chapter 4 for site assessment requirements.

#### **2.2.2.5.7 Permeable Pavement Subsurface Characterization**

See Volume 3, Appendix 1 for soils report requirements.

- Conduct pit/hole explorations during the wet season (December 1 through March 31st).
- Perform tests in the soil profile at the estimated bottom elevation of base materials for the permeable pavement. If no base materials, perform the testing at the estimated bottom elevation of the pavement.
- Subsurface explorations (test holes or test pits) to a depth below the base of the permeable pavement section of at least 1 foot.

- Subsurface characterization shall be conducted by a qualified engineer with geotechnical and hydrogeologic experience, or an equivalent professional acceptable to the City, under the seal of a registered Professional Engineer. The design engineer may utilize a team of certified or registered professionals in soil science, hydrogeology, geology, and other related fields.
- The professional can exercise discretion concerning the need for an extent of infiltration rate (saturated hydraulic conductivity) testing. The professional can consider a reduction in the extent of infiltration testing if, in their judgment, information exists confirming that the site is unconsolidated outwash material with high infiltration rates, and there is adequate separation from groundwater.
- Conduct a Small-Scale PIT Test per Volume 3, Section 6.5.2 for every 5,000 square feet of permeable pavement but not less than 1 test per site.
- On multi-lot residential developments, perform a Small-Scale PIT test at every proposed lot, at least every 200 feet of roadway and within each length of road with significant differences in subsurface characteristics.
- If the site subsurface characteristics across the site indicate consistent soil characteristics and depths to seasonal high groundwater conditions or hydraulic restriction layer, the number of test locations may be reduced to a frequency recommended by the geotechnical professional.
- If a permeable pavement will serve a drainage area exceeding 1 acre, a groundwater mounding analysis may be required.

### 2.2.2.5.8 Permeable Pavements - Correction Factors

The hydraulic saturated conductivity obtained from the PIT test is an initial rate. This initial rate shall be reduced through correction factors that are appropriate for the design situation to produce a design infiltration rate. Use the correction factor from Table 6 - 6 below or alternative values can be proposed based upon the professional judgment of the licensed engineer or site professional. Justification for alternate values must be provided to Environmental Services.

**Table 6 - 6: Measured Hydraulic Saturated Conductivity Rate Reduction Factors**

Issue	Partial Correction Factor
Site Variability and Number of Locations Tested	$CF_v = 0.33$ to 1.0
Quality of Pavement Aggregate Base Material	$CF_m = 0.9$ to 1

Total Correction Factor ( $CF_t$ ) =  $CF_v * CF_m$

The number of locations tested must be capable of producing a picture of the subsurface conditions that fully represents the conditions throughout the facility site. The partial correction factor used for site variability depends on the level of uncertainty that adverse subsurface conditions may occur. If the range of uncertainty is low - for example, conditions are known to be uniform through previous exploration and site geological factors - one pilot infiltration test (or grain size analysis location) may be adequate to justify a partial correction factor at the high end of the range.

If the level of uncertainty is high, a partial correction factor near the low end of the range may be appropriate. This might be the case where the site conditions are highly variable due to conditions such as a deposit of ancient landslide debris, or buried stream channels. In these cases, even with many explorations and several pilot infiltration tests (or several grain size test locations), the level of uncertainty may still be high.

A partial correction factor near the low end of the range could be assigned where conditions have a more typical variability, but few explorations and only one pilot infiltration test (or one grain size analysis location) is conducted. That is, the number of explorations and tests conducted do not match the degree of site variability anticipated.

A correction factor of 1 for the quality of pavement aggregate base material may be appropriate if the aggregate base is clean washed material with 1% or less fines passing the 200 sieve.

#### **2.2.2.5.9 Design Criteria**

At a minimum, comply with the design criteria in the sections below. The City of Tacoma Design Manual, Chapter 4 contains additional requirements for permeable pavement sections that are placed in the ROW. The Low Impact Development Technical Guidance Manual for Puget Sound is also a good guide for general guidance when designing permeable pavements.

##### **2.2.2.5.9.1 Subgrade**

Subgrade shall be a maximum 3% slope. If roadway surface exceeds 3%, subsurface detention structures per 2.2.2.5.9.5 may be required.

Compact the subgrade to the minimum necessary for structural stability and at a minimum be "firm and unyielding". See the City of Tacoma Right of Way Design Manual for additional subgrade preparation for applications within the City ROW. The exposed subgrade shall maintain preconstruction infiltration rates. The subgrade shall be protected during construction including minimizing traffic to the subgrade.

To prevent compaction when installing the aggregate base, the following steps are recommended:

- Dump aggregate onto subgrade from the edge of the installation.
- Dump subsequent aggregate base from on top of the aggregate base.

##### **2.2.2.5.9.2 Separation or Bottom Filter Layer**

A layer of sand or crushed stone (0.5 inches or smaller) is recommended to promote infiltration across the surface, stabilize the base layer, protect underlying soils from compaction, and serve as a transition between the base course and the underlying geotextile material or subgrade.

##### **2.2.2.5.9.3 Geotextile and GeoGrids (Optional)**

Geotextiles between the subgrade and aggregate base are not required or necessary for many soil types. Geotextile is recommended on the side slopes of the open graded base perimeter next to the soil subgrade if concrete curbs or impermeable liners are not provided that extend the full depth of the base.

##### **2.2.2.5.9.4 Permeable Ballast Base Course**

Refer to the City of Tacoma Standard Plan PD-01 for the minimum permeable ballast thickness necessary for structural integrity for permeable pavement roadways, accessways, and trails. The applicant shall submit WWHM calculations showing the proposed ballast thickness is sufficient as a reservoir layer to manage stormwater runoff based on the design criteria applicable to the project.

For private onsite permeable pavement surfaces, the minimum permeable ballast thickness shall be 6 inches for structural integrity and to function as a minimum reservoir layer. The applicant shall submit WWHM calculations showing the required ballast thickness is sufficient as a reservoir layer based on the design criteria applicable to the project. Projects required to comply

with Minimum Requirements #6, 7, or 8 shall submit WWHM calculations. Commercial projects where runoff from adjacent surfaces may reach the permeable pavement surface shall submit WWHM calculations. Single/family duplex projects are not required to submit calculations unless the permeable pavement surface is being used to meet Minimum Requirement #6, 7, or 8.

For pervious concrete sidewalks the minimum ballast thickness shall be 4 inches. Where runoff is minimized to the pervious sidewalk sections, calculations are not necessary to determine if the reservoir layer is sufficient for stormwater management. If runoff to the permeable sidewalk is allowed, additional modeling may be required by Environmental Services.

Permeable ballast base course shall meet the requirements of WSDOT Standard Specifications Section 9-03.9(2) - Permeable Ballast except as modified by this section. The permeable ballast base course shall be seated or compacted until no visible movement of aggregate is observed. Immediately following spreading and final shaping each layer of surfacing shall be lightly compacted in one lift to a firm and unyielding condition.

Permeable ballast base course shall not be manufactured from recycled concrete. The materials shall be uniform in quality and substantially free from wood, roots, bark, and other extraneous material and shall meet the following quality test requirements:

Los Angeles Wear, 500 Rev	30% maximum, WSDOT Test Method T 96
Degradation Factor:	30 minimum, WSDOT Test Method T 113
Minimum Void Ratio Content:	30% as determined by AASHTO T19 or ASTM C29, rodding procedure

**Table 6 - 7: Permeable Ballast Grading Requirement**

Sieve Size	Percent Passing <sup>1</sup>
2-1/2 inch	100
2 inch	90-100
1-1/2 inch	35-70
1 inch	0-15
1/2 inch	0-5
No. 100	0-3
No. 120	0
% Fracture	95

1.All percentages are by weight

The fracture requirement shall be at least two fractured face and will apply the combined aggregate retained on the No. 4 sieve in accordance with FOP for AASHTO T335. Permeable ballast base course shall meet the requirements for grading and quality when placed in hauling vehicles for delivery to the site, after placement in temporary location, when in stockpiles on site, during installation, and after installation and in place after compacted to project specifications.

**2.2.2.5.9.5 Subsurface Detention Structures**

For permeable pavements on slopes  $\geq 3\%$ , provide subsurface detention structures or terrace subgrade to increase infiltration, improve flow attenuation, and reduce structural issues with

subgrade erosion on slopes. See the “Low Impact Technical Guidance Manual for Puget Sound” for examples and design recommendations.

#### **2.2.2.5.9.6 Wearing Layer**

The wearing course includes the actual driving surface and the asphalt treated permeable base layer.

- For permeable pavement roadways and accessways refer to City of Tacoma Standard Plan PD-01 for minimum wearing layer thickness.
- For private onsite permeable pavement surfaces, the minimum wearing layer thickness shall be 4” for porous asphalt and 6” for pervious concrete though actual thickness shall be based on projected traffic use.
- The maximum slope for porous asphalt and permeable concrete shall be 10%.
- A minimum initial infiltration rate of 20 inches per hour is required. High infiltration rates are recommended.
- For porous asphalt, products shall have adequate void space, commonly 16-25%.
- For pervious concrete, products shall have adequate void space, commonly, 15-35%.
- For permeable interlocking concrete pavement and aggregate pavers, pavement joints should be filled with No. 8, 89, or 9 stone.
- For grid/lattice systems filled with gravel, sand, or a soil of finer particles with or without grass, the fill material shall be at least a minimum of 2 inches of sand, gravel, or soil.

#### **2.2.2.5.9.7 Permeable Pavement - Underdrain**

If an underdrain is placed at or near the bottom of the aggregate base in a permeable pavement design, the permeable pavement is not considered a low impact development technique and cannot be used to satisfy Minimum Requirement #5. Elevated underdrains that are placed within the aggregate base course to protect the pavement wearing course from saturation can be used to satisfy Minimum Requirement #5 though an underdrain is not required.

#### **2.2.2.5.9.8 Drainage Conveyance**

Ensure there is an appropriate conveyance path to safely move water away from the road prism.

#### **2.2.2.5.9.9 Acceptance Test**

- For driveways or small permeable pavement sections (1000 square feet or less), test by pouring a bucket of water on the permeable surface. Additional testing prior to acceptance will be needed if there is runoff from the surface.
- For permeable pavement sections greater than 1000 square feet, test the initial infiltration rate using ASTM C1701. Test to determine if the minimum infiltration rate of 10 inches per hour is met. The number of test locations is specified in ASTM C1701.

#### **2.2.2.5.10 Permeable Pavements – Maintenance**

- Per Minimum Requirement #9, an operation and maintenance plan shall be prepared for all stormwater facilities. See Volume 1, Appendix C for specific maintenance requirements. Maintenance shall be a basic consideration in design and cost-determination of the stormwater management facility.
- Any standing water or sediment removed during maintenance operation must be disposed of in a City approved manner. See the dewatering requirements in Volume 4 of

this manual. Pretreatment may be necessary. Solids must be disposed of in accordance with state and local waste regulations.

- Facilities shall be designed and constructed such that the facility can be safely and easily inspected by one person and safely and easily maintained.
- Follow manufacturer's suggestions for maintenance.
- Inspect project upon completion to correct accumulation of fine material. Conduct periodic visual inspections to determine if surfaces are clogged.
- Sweep non-planted surfaces with a high-efficiency sweeper twice per year, once in autumn and once in early spring. Sweeping frequency can be reduced if infiltration rate testing indicates that a rate of 10 inches/hour or greater is being maintained.
- The design engineer should consider the turning radius of the sweeper when designing permeable pavement surfaces to ensure the facility can be properly maintained
- Maintenance records shall be retained and provided to the City upon request.

#### **2.2.2.5.11 Permeable Pavements – Sizing Criteria and Flow Credits**

Modeling in WWHM is required to obtain flow credits and required for all projects except single/family duplex and sidewalks that are only required to comply with Minimum Requirements #1-#5. Model the facility using the Permeable Pavement element.

#### **2.2.2.6 BMP L634 Minimal Excavation Foundations**

##### **2.2.2.6.1 Purpose and Definition**

Minimal excavation foundation systems are those techniques that minimize disturbance to the natural soil profile within the footprint of the structure. This preserves most of the hydrologic properties of the native soil. Pin foundations are an example of a minimal excavation foundation.

##### **2.2.2.6.2 Applications Limitations**

- Heavy equipment cannot be used within or immediately surrounding the building. Terracing of the foundation area may be accomplished by tracked, blading equipment not exceeding 650 lbs/ft<sup>2</sup>.

##### **2.2.2.6.3 Design Criteria**

See Chapter 6 of “Low Impact Development: Technical Guidance Manual for Puget Sound” for design information.

##### **2.2.2.6.4 Flow Credits for Minimal Excavation Foundation Systems**

- Modeling in WWHM is required to obtain flow credits.
- Where roof runoff is dispersed on the up gradient side of a structure in accordance with the design criteria in “Downspout Dispersion”, model the tributary roof area as pasture on the native soil.
- Where “step forming” is used on a slope, the square footage of roof that can be modeled as pasture must be reduced to account for lost soils. In “step forming,” the building area is terraced in cuts of limited depth. This results in a series of level plateaus on which to erect the form boards.

The following equation can be used to reduce the roof area that can be modeled as pasture.

$$A_1 - \frac{dC(0.5)}{dP} \times A_1 = A_2$$

Where:

$A_1$  = roof area draining to up gradient side of structure

dC = depth of cuts into the soil profile

dP = permeable depth of soil (the A horizon plus an additional few inches of the B horizon where roots permeate into ample pore space of soil).

$A_2$  = roof area that can be modeled as pasture on the native soil

- If roof runoff is dispersed down gradient of the structure in accordance with the design criteria and guidelines in BMP L603: Downspout Dispersion, and there is at least 50 feet of vegetated flowpath through native material or lawn/landscape area that meets the guidelines in Volume 3, Chapter/Section 4.1 “BMP L613 Post-Construction Soil Quality and Depth” on page 39, model the tributary roof areas using the lateral flow element to send impervious area runoff onto the lawn/landscaped area that will be used for dispersion.

### **2.2.2.7 BMP L635 Reverse Slope Sidewalks**

#### **2.2.2.7.1 Definition and Purpose**

Reverse slope sidewalks are sloped to drain away from the road and onto adjacent vegetated areas.

#### **2.2.2.7.2 Design Criteria for Reverse Slope Sidewalks**

- There must be greater than 10 feet of vegetated surface downslope that is not directly connected into the storm drainage system.
- Vegetated area receiving flow from sidewalk must be native soil or meet the guidelines in Volume 3 Chapter/Section 4.1 “BMP L613 Post-Construction Soil Quality and Depth” on page 39.

#### **2.2.2.7.3 Flow Credits for Reverse Slope Sidewalks**

- Model the sidewalk area as landscaped area over the underlying soil type.
- Modeling in WWHM is required to obtain flow credits. Model the facility using the Lateral Flow Element to send impervious areas onto lawn areas for dispersion.

**This Page Intentionally Left Blank**



**This Page Intentionally Left Blank**

## **Appendix A Recommended Modifications to ASTM D2434 When Measuring Hydraulic Conductivity for Bioretention Soil Mixes**

Developed by the City of Seattle in cooperation with local soils laboratories.

Proctor method ASTM D1557 Method C (6-inch mold) shall be used to determine maximum dry density values for compaction of bioretention soil sample. Sample preparation for the Proctor test shall be amended in the following ways:

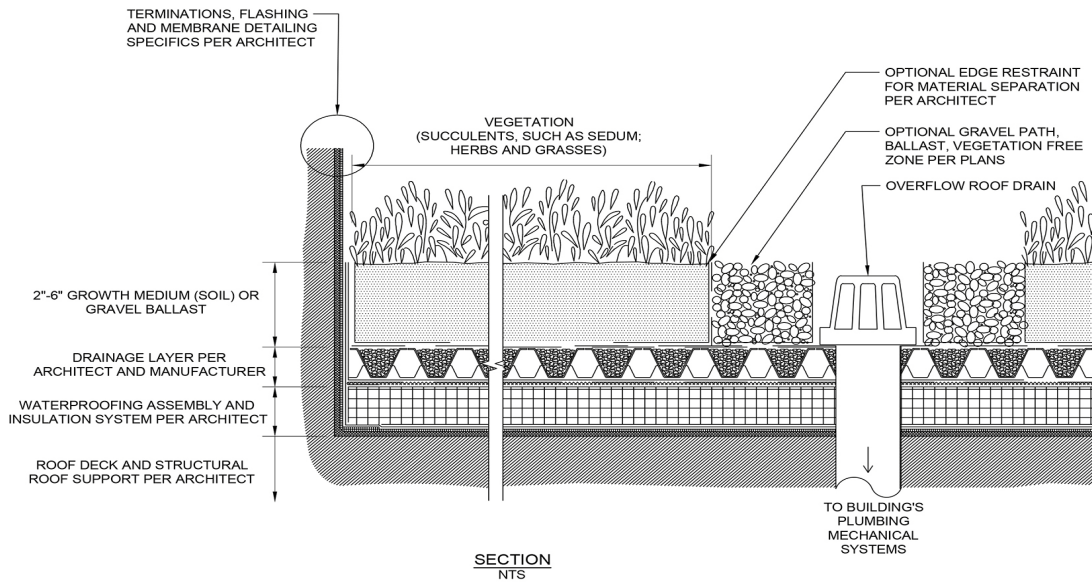
1. Maximum grain size within the sample shall be no more than ½ inches in size.
2. Snip larger organic particles (if present) into ½ inch long pieces.
3. When adding water to the sample during the Proctor test, allow the sample to pre-soak for at least 48 hours to allow the organics to fully saturate before compacting the sample. This pre-soak ensures the organics have been fully saturated at the time of the test.

ASTM D2434 shall be used and amended in the following ways:

1. Apparatus:
  - a. 6-inch mold size shall be used for the test.
  - b. If using porous stone disks for the testing, the permeability of the stone disk shall be measured before and after the soil tests to ensure clogging or decreased permeability has not occurred during testing.
  - c. Use the confined testing method, with 5- to 10-pound force spring
  - d. Use de-aired water.
2. Sample:
  - a. Maximum grain size within the sample shall not be more than ½ inch in size.
  - b. Snip larger organic particles (if present) into ½-inch long pieces.
  - c. Pre-soak the sample for at least 48 hours prior to loading it into the mold. During the pre-soak, the moisture content shall be higher than optimum moisture but less than full saturation (i.e., there shall be no free water). This pre-soak ensures the organics have been fully saturated at the time of the test.
3. Preparation of Sample:
  - a. Place soil in cylinder via a scoop.
  - b. Place soil in 1-inch lifts and compact using a 2-inch-diameter round tamper. Pre-weigh how much soil is necessary to fill 1-inch lift at 85% of maximum dry density, then tamp to 1-inch thickness. Once mold is full, verify that density is at 85% of maximum dry density (+ or – 0.5%). Apply vacuum (20 inches Hg) for 15 minutes before inundation.
  - c. Inundate sample slowly under a vacuum of 20 inches Hg over a period of 60 to 75 minutes.
  - d. Slowly remove vacuum (> 15 seconds).
  - e. Sample shall be soaked in the mold for 24 to 72 hours before starting test.

4. Procedure:
  - a. The permeability test shall be conducted over a range of hydraulic gradients between 0.1 and 2.
  - b. Steady state flow rates shall be documented for four consecutive measurements before increasing the head.
  - c. The permeability test shall be completed within one day (one-day test duration).

# Appendix B Green Stormwater Infrastructure Details



**NOTES:**

1. This is a conceptual plan for an extensive vegetated rooftop. See SWMM BMP L631 for design requirements.

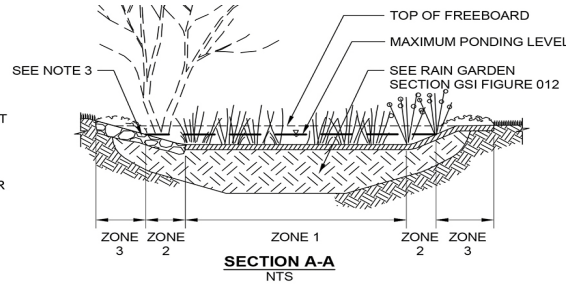
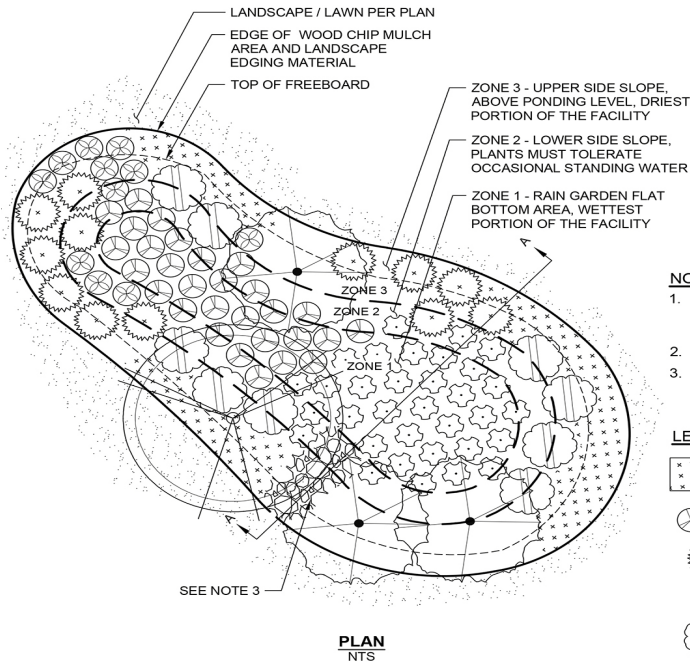


**CITY OF TACOMA  
GREEN STORMWATER INFRASTRUCTURE  
TYPICAL DETAILS**

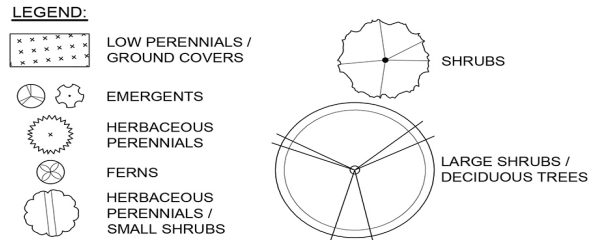
**VEGETATED ROOF SECTION**

**FIGURE NO.**

**010  
January 2016**

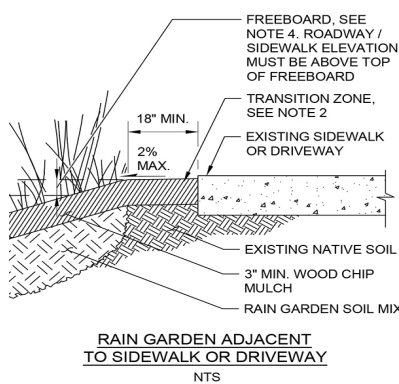
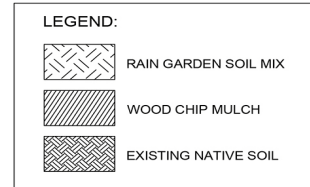
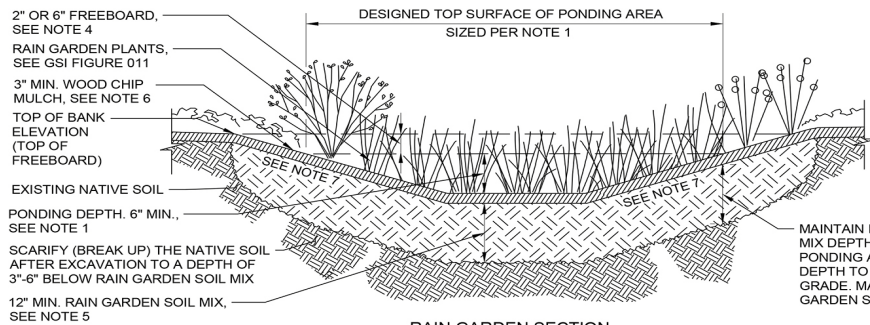


- NOTES:**
1. For guidance on plants for each zone and for example planting plans see the 2013 Rain Garden Handbook for Western Washington, available at [CityofTacoma.org/raingardens](http://CityofTacoma.org/raingardens).
  2. Choose a minimum 50% evergreen plants.
  3. Keep plants clear of inlet, outlet and/or overflows.



**CITY OF TACOMA GREEN STORMWATER INFRASTRUCTURE TYPICAL DETAILS**

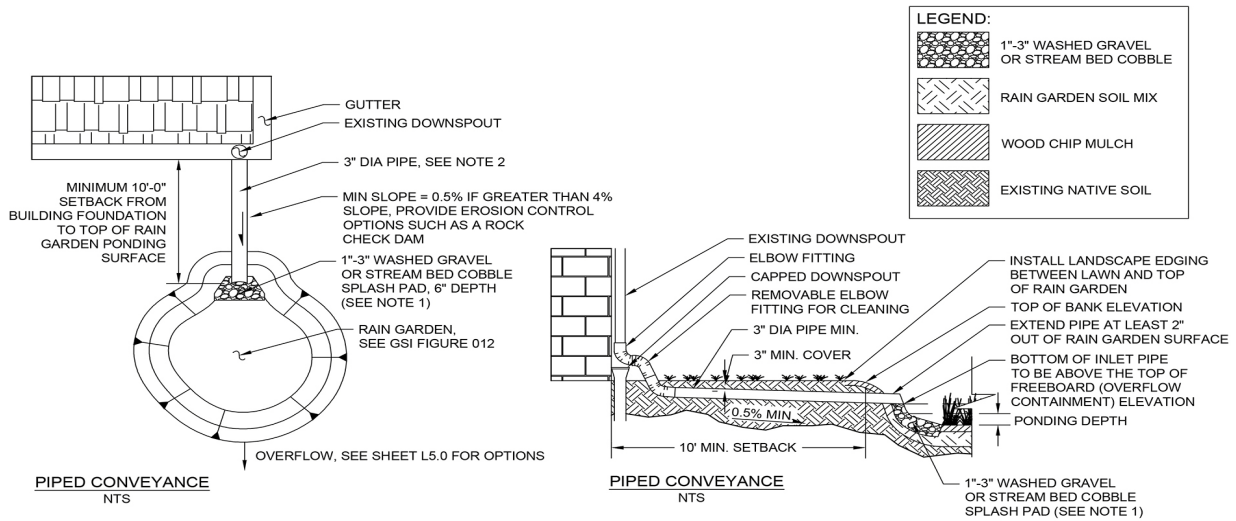
**RAIN GARDEN - PLANTING ZONES**  
 FIGURE NO. 011  
 January 2016



- RAIN GARDEN SECTION NTS**
- NOTES:**
1. Rain gardens sized for compliance with MR #5 shall be in accordance with SWMM BMP L601, available at [www.cityoftacoma.org/stormwatermanual](http://www.cityoftacoma.org/stormwatermanual). Rain gardens not required to comply with SWMM can be sized per the Rain Garden Handbook for Western Washington, available at [cityoftacoma.org/raingardens](http://cityoftacoma.org/raingardens) - where sizing is based upon depth of either 6-inches or 12-inches of ponding.
  2. Transition zone
    - a. 1-inch grade change from edge of sidewalk, curb and/or other hard surface.
    - b. 2% max. slope.
    - c. Transition shall be amended soils per BMP L613 (Std. Plan GSI-01) if applicable or per note 3.
  3. Scarify or till subgrade to 3-inch depth. Place 3-inches of topsoil on surface and till into 5-inches of site soil. Install 3-inches woodchip mulch or as specified on plans.
  4. Freeboard shall be a minimum of 2-inches for contributing areas under 1,000 square feet, or 6-inches for contributing areas 1,000 square feet or greater per SWMM.
  5. Do not compact the rain garden soil mix.
    - a. Do not operate heavy equipment within the the rain garden.
    - b. Do not place or amend rain garden soil when the ground is frozen or when the soil is excessively wet.
  6. Continue mulch for a minimum of 2-feet past the top of bank elevation or install landscape edging if rain garden is adjacent to turf.
  7. Maximum side slope (2:1 or 3:1) varies with size of contributing area. See SWMM BMP L601 or the Rain Garden Handbook for Western Washington, as applicable.

**CITY OF TACOMA GREEN STORMWATER INFRASTRUCTURE TYPICAL DETAILS**

**RAIN GARDEN SECTION**  
 FIGURE NO. 012  
 January 2016



**NOTES:**

1. Gravel or stream bed cobble splash pad minimum depth of 6 inches. Rock splash pad shall be minimum of 1 foot wide and extend beyond the pipe outlet by a minimum of 1 foot.
2. Pipe shall be per SWMM Volume 3.



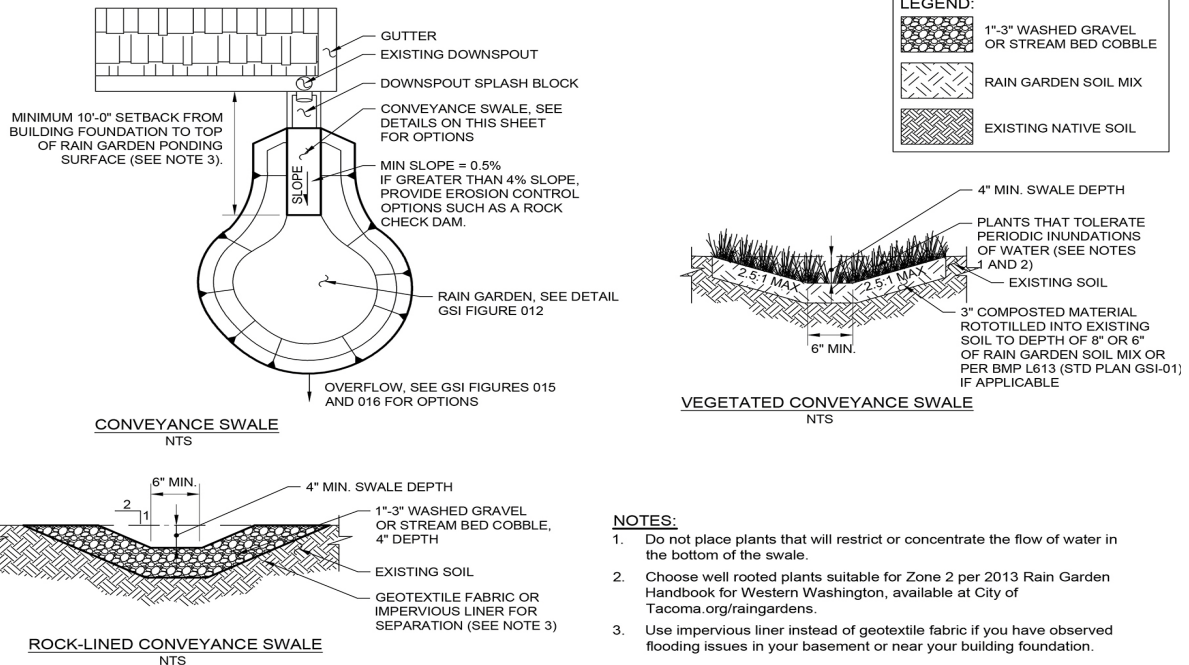
**CITY OF TACOMA GREEN STORMWATER INFRASTRUCTURE TYPICAL DETAILS**

**RAIN GARDEN PIPED INLET**

FIGURE NO.

013

January 2016



**NOTES:**

1. Do not place plants that will restrict or concentrate the flow of water in the bottom of the swale.
2. Choose well rooted plants suitable for Zone 2 per 2013 Rain Garden Handbook for Western Washington, available at City of Tacoma.org/raingardens.
3. Use impervious liner instead of geotextile fabric if you have observed flooding issues in your basement or near your building foundation.



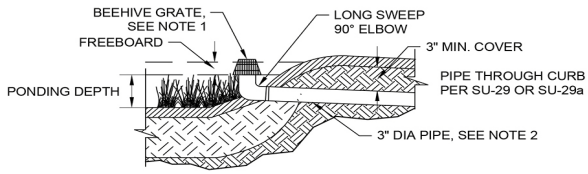
**CITY OF TACOMA GREEN STORMWATER INFRASTRUCTURE TYPICAL DETAILS**

**RAIN GARDEN INLET SWALE**

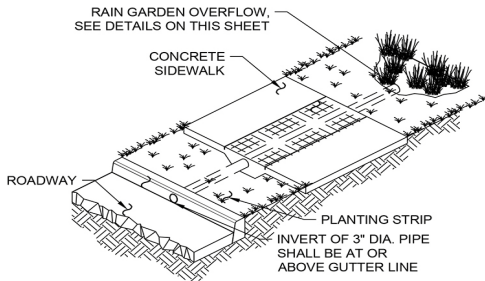
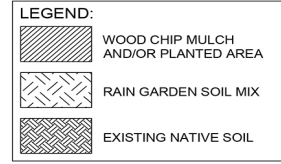
FIGURE NO.

014

January 2016

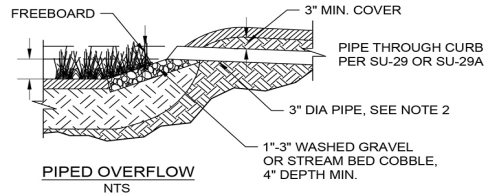


**BEEHIVE OVERFLOW**  
NTS



SEE STD PLAN SU-29 OR SU-29A FOR CONSTRUCTION REQUIREMENTS.

**OVERFLOW PIPE THROUGH SIDEWALK TO CURB**  
NTS



**PIPED OVERFLOW**  
NTS

**NOTES:**

1. Beehive grate must be made of UV stabilized material.
2. Pipe per the City of Tacoma SWMM Volume 3 for privately maintained pipe to edge of ROW. Pipe within ROW shall be per SU-29 or SU-29a.



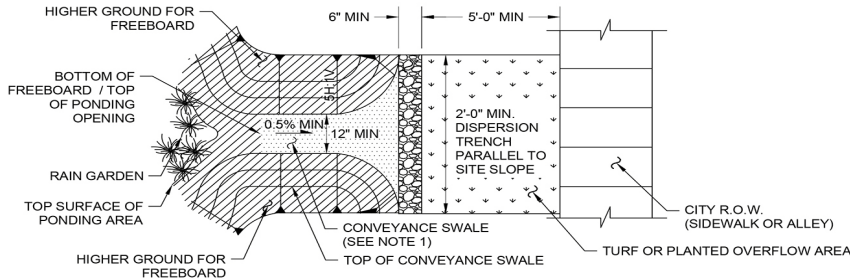
**CITY OF TACOMA  
GREEN STORMWATER INFRASTRUCTURE  
TYPICAL DETAILS**

**RAIN GARDEN PIPED OVERFLOW**

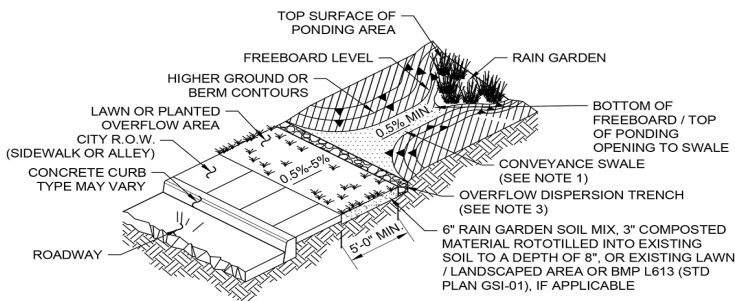
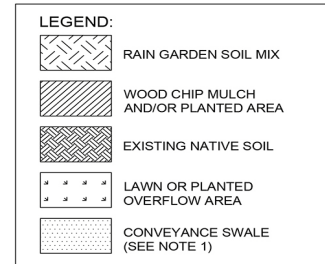
FIGURE NO.

015

January 2016



**OVERFLOW THROUGH CONVEYANCE SWALE TO R.O.W.**  
NTS



**OVERFLOW THROUGH CONVEYANCE SWALE TO R.O.W.**  
NTS

**NOTES:**

1. See GSI Figure 015 for conveyance swale detail.
2. Minimum slope = 0.5%. If greater than 0.4% slope, provide erosion control options such as a rock check dam.
3. Overflow dispersion trench consists of a minimum 6" wide by 6" deep by 24" long drain rock layer lined with geotextile fabric on the sides and bottom for separation.



**CITY OF TACOMA  
GREEN STORMWATER INFRASTRUCTURE  
TYPICAL DETAILS**

**RAIN GARDEN WITH SWALE OVERFLOW**

FIGURE NO.

016

January 2016

**This Page Intentionally Left Blank**



**This Page Intentionally Left Blank**

# Glossary

The following terms are provided for reference and use with this manual. They shall be superseded by any other definitions for these terms adopted by ordinance, unless they are defined in a Washington State WAC or RCW, or are used and defined as part of the Minimum Requirements for all new development and redevelopment.

<b>AASHTO classification</b>	The official classification of soil materials and soil aggregate mixtures for highway construction, used by the American Association of State Highway and Transportation Officials.
<b>Absorption</b>	The penetration of a substance into or through another, such as the dissolving of a soluble gas in a liquid.
<b>Adjacent steep slope</b>	A slope with a gradient of 20 percent or steeper within five hundred feet of the site.
<b>Adjustment</b>	A variation in the application of a Minimum Requirement to a particular project. Adjustments provide equivalent environmental protection.
<b>Adsorption</b>	The adhesion of a substance to the surface of a solid or liquid; often used to extract pollutants by causing them to be attached to such adsorbents as activated carbon or silica gel. Hydrophobic, or water-repulsing adsorbents, are used to extract oil from waterways when oil spills occur. Heavy metals such as zinc and lead often adsorb onto sediment particles.
<b>Aeration</b>	The process of being supplied or impregnated with air. In waste treatment, the process used to foster biological and chemical purification. In soils, the process by which air in the soil is replenished by air from the atmosphere. In a well aerated soil, the soil air is similar in composition to the atmosphere above the soil. Poorly aerated soils usually contain a much higher percentage of carbon dioxide and a correspondingly lower percentage of oxygen.
<b>Aerobic</b>	Living or active only in the presence of free (dissolved or molecular) oxygen.
<b>Aerobic bacteria</b>	Bacteria that require the presence of free oxygen for their metabolic processes.
<b>Aggressive plant species</b>	Opportunistic species of inferior biological value that tend to out-compete more desirable forms and become dominant; applied to native species in this manual.
<b>Algae</b>	Primitive plants, many microscopic, containing chlorophyll and forming the base of the food chain in aquatic environments. Some species may create a nuisance when environmental conditions are suitable for prolific growth.

<b>Algal bloom</b>	Proliferation of living algae on the surface of lakes, streams or ponds; often stimulated by phosphate over-enrichment. Algal blooms reduce the oxygen available to other aquatic organisms.
<b>American Public Works Association (APWA)</b>	The Washington State Chapter of the American Public Works Association.
<b>Anadromous</b>	Fish that grow to maturity in the ocean and return to rivers for spawning.
<b>Anaerobic</b>	Living or active in the absence of oxygen.
<b>Anaerobic bacteria</b>	Bacteria that do not require the presence of free or dissolved oxygen for metabolism.
<b>Annual flood</b>	The highest peak discharge on average which can be expected in any given year.
<b>Antecedent moisture conditions</b>	The degree of wetness of a watershed or within the soil at the beginning of a storm.
<b>Anti-seep collar</b>	A device constructed around a pipe or other conduit and placed through a dam, levee, or dike for the purpose of reducing seepage losses and piping failures.
<b>Anti-vortex device</b>	A facility placed at the entrance to a pipe conduit structure such as a drop inlet spillway or hood inlet spillway to prevent air from entering the structure when the pipe is flowing full.
<b>Applicant</b>	The person who has applied for a development permit or approval.
<b>Appurtenances</b>	Machinery, appliances, or auxiliary structures attached to a main structure, but not considered an integral part thereof, for the purpose of enabling it to function.
<b>Aquatic Life Use</b>	Waterbodies as defined in WAC 173-201A-600 and WAC 173-201A-602.
<b>Aquifer</b>	A geologic stratum containing groundwater that can be withdrawn and used for human purposes.
<b>Arborescent shrubs</b>	Shrubs (woody perennials) that are tree-like but typically multi-stemmed, unable to be trained into a single stem and typically attain a height of 15 feet or less at maturity.
<b>Arterial</b>	A road or street primarily for through traffic. A major arterial connects an Interstate Highway to cities and counties. A minor arterial connects major arterials to collectors. A collector connects an arterial to a neighborhood. A collector is not an arterial. A local access road connects individual homes to a collector.

<b>As-built drawings</b>	Engineering plans which have been revised to reflect all changes to the plans which occurred during construction.
<b>As-graded</b>	The extent of surface conditions on completion of grading.
<b>Background</b>	A description of pollutant levels arising from natural sources, and not due to human activities.
<b>Backwater</b>	Water upstream from an obstruction which is deeper than it would normally be without the obstruction.
<b>Baffle</b>	A device to check, deflect, or regulate flow.
<b>Bank full discharge</b>	A flow condition where streamflow completely fills the stream channel up to the top of the bank. In undisturbed watersheds, the discharge conditions occur on average every 1.5 to 2 years and controls the shape and form of natural channels.
<b>Base flood</b>	A flood having a one percent chance of being equaled or exceeded in any given year. This is also referred to as the 100-year flood.
<b>Base flood elevation</b>	The water surface elevation of the base flood. It shall be referenced to the National Geodetic Vertical Datum of 1929 (NGVD).
<b>Baseflow</b>	Portion of flow that comes from groundwater.
<b>Baseline sample</b>	A sample collected during dry-weather flow (i.e., it does not consist of runoff from a specific precipitation event).
<b>Basin</b>	An area draining to a particular outfall.

**Basin plan**

A plan that assesses, evaluates, and proposes solutions to existing and potential future impacts to the beneficial uses of, and the physical, chemical, and biological properties of waters of the state within a basin. Basins typically range in size from 1 to 50 square miles. A plan should include but not be limited to recommendations for:

- Stormwater requirements for new development and redevelopment;
- Capital improvement projects;
- Land Use management through identification and protection of critical areas, comprehensive land use and transportation plans, zoning regulations, site development standards, and conservation areas;
- Source control activities including public education and involvement, and business programs;
- Other targeted stormwater programs and activities, such as maintenance, inspections and enforcement;
- Monitoring; and
- An implementation schedule and funding strategy.

A plan that is “adopted and implemented” must have the following characteristics:

- It must be adopted by legislative or regulatory action of jurisdictions with responsibilities under the plan;
- Ordinances, regulations, programs, and procedures recommended by the plan should be in effect or on schedule to be in effect; and,
- An implementation schedule and funding strategy that are in progress.

**Bearing capacity**

The maximum load that a material can support before failing.

**Bedrock**

The more or less solid rock in place either on or beneath the surface of the earth. It may be soft, medium, or hard and have a smooth or irregular surface.

**Bench**

A relatively level step excavated into earth material on which fill is to be placed.

**Berm**

A constructed barrier of compacted earth, rock, or gravel. In a stormwater facility, a berm may serve as a vertical divider typically built up from the bottom.

**Best management practice (BMP)**

The schedules of activities, prohibitions of practices, maintenance procedures, and structural and/or managerial practices, that when used singly or in combination, prevent or reduce the release of pollutants and other adverse impacts to waters of Washington State.

<b>Biochemical oxygen demand (BOD)</b>	An indirect measure of the concentration of biologically degradable materials present in organic wastes. The amount of free oxygen utilized by aerobic organisms when allowed to attack the organic material in an aerobically maintained environment at a specified temperature (20°C) for a specific time period (5 days), and thus stated as BOD5. It is expressed in milligrams of oxygen utilized per liter of liquid waste volume (mg/l) or in milligrams of oxygen per kilogram of waste solution (mg/kg = ppm = parts per million parts). Also called biological oxygen demand.
<b>Biodegradable</b>	Capable of being readily broken down by biological means, especially by microbial action. Microbial action includes the combined effect of bacteria, fungus, flagellates, amoebae, ciliates, and nematodes. Degradation can be rapid or may take many years depending upon such factors as available oxygen and moisture.
<b>Bioengineering</b>	The combination of biological, mechanical, and ecological concepts (and methods) to control erosion and stabilize soil through the use of vegetation or in combination with construction materials.
<b>Biofilter</b>	A designed treatment facility using a combined soil and vegetation system for filtration, infiltration, adsorption, and biological uptake of pollutants in stormwater when runoff flows over and through. Vegetation growing in these facilities acts as both a physical filter which causes gravity settling of particulates by regulating velocity of flow, and also as a biological sink when direct uptake of dissolved pollutants occurs. The former mechanism is probably the most important in western Washington where the period of major runoff coincides with the period of lowest biological activity.
<b>Biofiltration</b>	The process of reducing pollutant concentrations in water by filtering the polluted water through biological materials.
<b>Biological control</b>	A method of controlling pest organisms by means of introduced or naturally occurring predatory organisms, sterilization, the use of inhibiting hormones, or other means, rather than by mechanical or chemical means.
<b>Biological magnification</b>	The increasing concentration of a substance along succeeding steps in a food chain. Also called biomagnification.
<b>Bioretention</b>	Engineered facilities that store and treat stormwater by passing it through a specified soil profile, and either retain or detain the treated stormwater for full infiltration or flow attenuation. Refer to Volume 6 for bioretention types and design specifications.

<b>Biosolids</b>	Municipal sewage sludge that is a primarily organic, semisolid product resulting from the wastewater treatment process, that can be beneficially recycled and meets all applicable requirements under Chapter 173-308 WAC. Biosolids include a material derived from biosolids and septic tank sludge, also known as septage, that can be beneficially recycled and meets all applicable requirements under Chapter 173-308 WAC. For the purposes of Chapter 173-308 WAC, semisolid products include biosolids or products derived from biosolids ranging in character from mostly liquid to fully dried solids.
<b>Bituminous surface treatment</b>	<p>A temporary surface treatment provided to control dust and assist in the control of erosion. An unimproved roadway that receives this treatment does not meet the City of Tacoma Standard Roadway Design.</p> <p>When upgrading from bituminous surface treatment to asphalt or concrete, the surface is considered a new impervious surfaces. See Volume 1, Section 3.2.1 for Pavement Maintenance Exemptions.</p>
<b>Bollard</b>	A post (may or may not be removable) used to prevent vehicular access.
<b>Bond</b>	A surety bond, cash deposit or escrow account, assignment of savings, irrevocable letter of credit or other means acceptable to or required by the manager to guarantee that work is completed in compliance with the project's drainage plan and in compliance with all local government requirements.
<b>Borrow area</b>	A source of earth fill material used in the construction of embankments or other earth fill structures.
<b>Breast height</b>	See Diameter at Breast Height.
<b>Buffer</b>	The zone contiguous with a sensitive area that is required for the continued maintenance, function, and structural stability of the sensitive area. The critical functions of a riparian buffer (those associated with an aquatic system) include shading, input of organic debris and coarse sediments, uptake of nutrients, stabilization of banks, interception of fine sediments, overflow during high water events, protection from disturbance by humans and domestic animals, maintenance of wildlife habitat, and room for variation of aquatic system boundaries over time due to hydrologic or climatic effects. The critical functions of terrestrial buffers include protection of slope stability, attenuation of surface water flows from stormwater runoff and precipitation, and erosion control.

<b>Building setback line (BSBL)</b>	A line measured parallel to a property, easement, drainage facility, or buffer boundary, that delineates the area (defined by the distance of separation) where buildings or other obstructions are prohibited (including decks, patios, outbuildings, or overhangs beyond 18 inches). Wooden or chain link fences and landscaping are allowable within a building setback line. In this manual the minimum building setback line shall be 5 feet.
<b>Capital Improvement Project or Program (CIP)</b>	A project prioritized and scheduled as a part of an overall construction program or the actual construction program.
<b>Catch basin</b>	A chamber or well, usually built at the curb line of a street, for the admission of surface water to a sewer or subdrain, having at its base a sediment sump designed to retain grit and detritus below the point of overflow.
<b>Catchline</b>	The point where a severe slope intercepts a different, more gentle slope.
<b>Catchment</b>	Surface drainage area.
<b>Cation Exchange Capacity (CEC)</b>	The degree to which a soil can absorb and exchange cations, at a given pH. Typically defined in milliequivalents per 100 grams of soil (meq/100 g soil). Soil found to have a CEC of 5 meq at pH 7 will have CEC <5 meq when pH <7.
<b>Certified Erosion and Sediment Control Lead (CESCL)</b>	An individual who is knowledgeable in the principles and practices of erosion and sediment control. The CESCL must have the skills to assess: the site conditions and construction activities that could impact the quality of the stormwater; and the effectiveness of erosion and sediment control measures used to control the quality of stormwater discharges. The CESCL must have current certification through an approved erosion and sediment control training program that meets the minimum training standards established by Ecology
<b>Certified Professional in Erosion and Sediment Control (CPESC)</b>	An individual who has educational training, expertise and experience in controlling erosion and sedimentation, and has met certification standards. The CPESC shall have a current certification through a program approved by Ecology.
<b>Channel</b>	A feature that conveys surface water and is open to the air.
<b>Channel, constructed</b>	Channels or ditches constructed (or reconstructed natural channels) to convey surface water.
<b>Channel, natural</b>	Streams, creeks, or swales that convey surface/groundwater and have existed long enough to establish a stable route and/or biological community.



<b>Channel stabilization</b>	Erosion prevention and stabilization of velocity distribution in a channel using vegetation, jetties, drops, revetments, and/or other measures.
<b>Channelization</b>	Alteration of a stream channel by widening, deepening, straightening, cleaning, or paving certain areas which changes characteristics.
<b>Check dam</b>	Small dam constructed in a gully, swale, or other small watercourse to decrease the streamflow velocity, minimize channel scour, and promote deposition of sediment.
<b>Chemical oxygen demand (COD)</b>	A measure of the amount of oxygen required to oxidize organic and oxidizable inorganic compounds in water. The COD test, like the BOD test, is used to determine the degree of pollution in water.
<b>Chip Seal</b>	In the City of Tacoma, chip sealing is a maintenance practice currently used to extend the life of existing asphalt or concrete roadways. The practice involves applying asphalt emulsion and chip rock to the existing asphalt or concrete section. On roadways that have received a chip seal maintenance application, when overlaying with asphalt or concrete, the overlain sections of roadway will not be considered new or replaced impervious surfaces and will not be counted toward the project thresholds. See Volume 1, Section 3.2.1 for Pavement Maintenance Exemptions.
<b>City Block</b>	A City block shall be defined by existing arterial or residential roads. A City block shall not be defined by alleys.
<b>Civil engineer</b>	A professional engineer licensed in the State of Washington in Civil Engineering.
<b>Civil engineering</b>	The application of the knowledge of the forces of nature, principles of mechanics and the properties of materials to the evaluation, design and construction of civil works for the beneficial uses of mankind.
<b>Clay lens</b>	A naturally-occurring localized area of clay which acts as an impermeable layer to runoff infiltration.
<b>Clearing</b>	The destruction and removal of vegetation by manual, mechanical, or chemical methods.
<b>Closed depression</b>	An area which is low-lying and either has no, or such a limited, surface water outlet that during storm events the area acts as a retention basin.
<b>Cohesion</b>	The capacity of a soil to resist shearing stress, exclusive of functional resistance.

<b>Coliform bacteria</b>	Microorganisms common in the intestinal tracts of man and other warm-blooded animals; all the aerobic and facultative anaerobic, gram-negative, nonspore-forming, rod-shaped bacteria which ferment lactose with gas formation within 48 hours at 35°C. Used as an indicator of bacterial pollution.
<b>Commercial agriculture</b>	Those activities conducted on lands defined in RCW 84.34.020(2), and activities involved in the production of crops or livestock for commercial trade. An activity ceases to be considered commercial agriculture when the area on which it is conducted is proposed for conversion to a nonagricultural use or has lain idle for more than five (5) years, unless the idle land is registered in a federal or state soils conservation program, or unless the activity is maintenance of irrigation ditches, laterals, canals, or drainage ditches related to an existing and ongoing agricultural activity.
<b>Commercial sites</b>	Sites not considered residential, industrial or road-related.

### **Common Plan of Development**

A project site where multiple separate and distinct construction activities may be taking place at different times on different schedules and/or by different contractors, but still under a single plan. Examples include:

1. Phased projects and projects with multiple filings or lots, even if the separate phases or filings/lots will be constructed under separate contract or by separate owners (e.g., a plat or short plat where lots are sold to separate builders).
2. A development plan that may be phased over multiple years, but is still under a consistent plan for long-term development.
3. New development or redevelopment in contiguous areas that may be unrelated but still under the same contract, such as construction of a building extension and a new parking lot at the same facility.
4. New development or redevelopment on contiguous lots that are not associated with a land use action, that are owned by a single entity, even if construction on the lots will not occur at the same time.
5. New development or redevelopment on non-contiguous lots that are located on the same City block and discharge to the same threshold discharge area, owned by a single entity, even if construction will not occur at the same time.
6. New development or redevelopment on linear projects such as roads, pipelines, or utilities.

If the project is part of a common plan of development or sale, the disturbed area of the entire plan must be used to determine permit requirements. Conveyances into different ownership for the ostensible purpose of avoiding more comprehensive stormwater review and requirements, or where an innocent conveyance has this effect, may be considered to be part of a Common Plan of Development and reviewed by Environmental Services for cumulative impacts.

### **Compaction**

The densification, settlement, or packing of soil in such a way that permeability of the soil is reduced. Compaction effectively shifts the performance of a hydrologic group to a lower permeability hydrologic group. For example, a group B hydrologic soil can be compacted and be effectively converted to a group C hydrologic soil in the way it performs in regard to runoff.

Compaction may also refer to the densification of a fill by mechanical means.

<b>Compensatory storage</b>	New excavated storage volume equivalent to the flood storage capacity eliminated by filling or grading within the flood fringe. Equivalent shall mean that the storage removed shall be replaced by equal volume between corresponding one-foot contour intervals that are hydraulically connected to the floodway through their entire depth.
<b>Compost</b>	Organic material that has undergone biological degradation and transformation under controlled conditions designed to promote aerobic decomposition at a solid waste facility in compliance with the requirements of Chapter 173-350 WAC, or biosolids composted in compliance with Chapter 173-308 WAC. Composting is a form of organic material recycling. Natural decay of organic solid waste under uncontrolled conditions does not result in composted material. (Note: Various BMPs have restrictions on the percentage of biosolids in compost or do not allow biosolids in compost.)
<b>Composted Mulch</b>	Mulch prepared from decomposed organic materials that have undergone a controlled process to minimize weed seeds. Acceptable feedstocks include, but are not limited to, yard debris, wood waste, land clearing debris, brush, and branches.
<b>Composting</b>	The biological degradation and transformation of organic solid waste under controlled conditions designed to promote aerobic decomposition. Natural decay of organic solid waste under uncontrolled conditions is not composting.
<b>Comprehensive planning</b>	Planning that takes into account all aspects of water, air, and land resources and their uses and limits.
<b>Conservation district</b>	A public organization created under state enabling law as a special-purpose district to develop and carry out a program of soil, water, and related resource conservation, use, and development within its boundaries, usually a subdivision of state government with a local governing body and always with limited authority. Often called a soil conservation district or a soil and water conservation district.
<b>Constructed wetland</b>	Artificial wetlands created where wetlands do not currently exist for managing stormwater discharges. Constructed wetlands are considered part of the stormwater system.
<b>Construction Stormwater Pollution Prevention Plan (SWPPP)</b>	A document that describes the potential for pollution problems on a construction project and explains and illustrates the measures to be taken on the construction site to control those problems.
<b>Contour</b>	An imaginary line on the surface of the earth connecting points of the same elevation.

<b>Converted vegetation (areas)</b>	The surfaces on a project site where native vegetation, pasture, scrub/shrub, uncultivated vegetation, or unmaintained non-native vegetation (e.g., Himalayan blackberries, scotch broom) are converted to lawn to lawn or landscaped areas, or where native vegetation is converted to pasture.
<b>Conveyance</b>	A mechanism for transporting water from one point to another, including pipes, ditches, and channels.
<b>Conveyance system</b>	The drainage facilities, both natural and man-made, which collect, contain, and provide for the flow of surface and stormwater from the highest points on the land down to a receiving water. The natural elements of the conveyance system include swales and small drainage courses, streams, rivers, lakes, and wetlands. The human-made elements of the conveyance system include gutters, ditches, pipes, channels, and most retention/detention facilities.
<b>Cover crop</b>	A close-growing crop grown primarily for the purpose of protecting and improving soil between periods of permanent vegetation.
<b>Created wetland</b>	Wetlands intentionally created from nonwetland sites to produce or replace natural wetland habitat (e.g., compensatory mitigation projects).
<b>Critical Areas</b>	At a minimum, areas which include wetlands, stream corridors, areas with a critical recharging effect on aquifers used for potable water, fish and wildlife habitat conservation areas, frequently flooded areas, geologically hazardous areas, including unstable slopes, and associated areas and ecosystems.
<b>Critical root zone (CRZ)</b>	An area equal to 1-foot radius from the base of the tree's trunk for each 1-inch of the tree's diameter at 4.5 feet above grade (diameter at breast height).
<b>Critical reach</b>	The point in a receiving stream below a discharge point at which the lowest dissolved oxygen level is reached and stream recovery begins.
<b>Crown (pipe)</b>	The highest point of the internal surface of the transverse cross section of a pipe.
<b>Crown (tree)</b>	The upper part of the tree, measured from the lowest branch, including all the branches and foliage.
<b>Culvert</b>	Pipe or concrete box structure that drains open channels, swales or ditches under a roadway or embankment. Typically with no catchbasins or manholes along its length.
<b>Cut</b>	Portion of land surface or area from which earth has been removed or will be removed by excavating; the depth below original ground surface to excavated surface.

<b>Cut-and-fill</b>	Process of earth moving by excavating part of an area and using the excavated material for adjacent embankments or fill areas.
<b>Cut slope</b>	A slope formed by excavating overlying material to connect the original ground surface with a lower ground surface created by the excavation. A cut slope is distinguished from a bermed slope, which is constructed by importing soil to create the slope.
<b>DNS</b>	See Determination of Nonsignificance.
<b>Dead storage</b>	The volume available in a depression in the ground below any conveyance system, or surface drainage pathway, or outlet invert elevation that could allow the discharge of surface and stormwater runoff.
<b>Deciduous</b>	A tree that sheds foliage at the end of the growing season.
<b>Dedication of land</b>	Refers to setting aside a portion of a property for a specific use or function.
<b>Degradation</b>	(Biological or chemical) The breakdown of complex organic or other chemical compounds into simpler substances, usually less harmful than the original compound, as with the degradation of a persistent pesticide. (Geological) Wearing down by erosion. (Water) The lowering of the water quality of a watercourse by an increase in the pollutant loading.
<b>Degraded (disturbed) wetland (community)</b>	A wetland (community) in which the vegetation, soils, and/or hydrology have been adversely altered, resulting in lost or reduced functions and values; generally, implies topographic isolation; hydrologic alterations such as hydroperiod alteration (increased or decreased quantity of water), diking, channelization, and/or outlet modification; soils alterations such as presence of fill, soil removal, and/or compaction; accumulation of toxicants in the biotic or abiotic components of the wetland; and/or low plant species richness with dominance by invasive weedy species.
<b>Denitrification</b>	The biochemical reduction of nitrates or nitrites in the soil or organic deposits to ammonia or free nitrogen.
<b>Depression storage</b>	The amount of precipitation that is trapped in depressions on the surface of the ground.
<b>Design engineer</b>	The professional civil engineer licensed in the State of Washington who prepares the analysis, design, and engineering plans for an applicant's permit or approval submittal.

<b>Design storm</b>	A prescribed hyetograph and total precipitation amount (for a specific duration recurrence frequency) used to estimate runoff for a hypothetical storm of interest or concern for the purposes of analyzing existing drainage, designing new drainage facilities or assessing other impacts of a proposed project on the flow of surface water. (A hyetograph is a graph of percentages of total precipitation for a series of time steps representing the total time during which the precipitation occurs.)
<b>Detention</b>	The release of stormwater runoff from the site at a slower rate than it is collected by the stormwater facility system, the difference being held in temporary storage.
<b>Detention facility</b>	An above or below ground facility, such as a pond or tank, that temporarily stores stormwater runoff and subsequently releases it at a slower rate than it is collected by the drainage facility system. There is little or no infiltration of stored stormwater.
<b>Detention time</b>	The theoretical time required to displace the contents of a stormwater treatment facility at a given rate of discharge (volume divided by rate of discharge).
<b>Determination of Nonsignificance (DNS)</b>	The written decision by the responsible official of the lead agency that a proposal is not likely to have a significant adverse environmental impact, and therefore an EIS is not required.
<b>Development</b>	Means new development, redevelopment, or both. See definitions for each.
<b>Diameter at breast height (DBH)</b>	Diameter of the tree trunk from 4.5 feet above the ground.
<b>Discharge</b>	Runoff leaving a new development or redevelopment via overland flow, built conveyance systems, or infiltration facilities. A hydraulic rate of flow, specifically fluid flow; a volume of fluid passing a point per unit of time, commonly expressed as cubic feet per second, cubic meters per second, gallons per minute, gallons per day, or millions of gallons per day.
<b>Discharge Point</b>	The location where a discharge leaves the Permittee's MS4 through the Permittee's MS4 facilities/BMPs designed to infiltrate.
<b>Dispersion</b>	Release of surface and stormwater runoff from a drainage facility system such that the flow spreads over a wide area and is located so as not to allow flow to concentrate anywhere upstream of a drainage channel with erodible underlying granular soils.
<b>Disturb</b>	See Land Disturbing Activity
<b>Ditch</b>	A long narrow excavation dug in the earth for drainage with its top width less than 10 feet at design flow.

<b>Divide, Drainage</b>	The boundary between one drainage basin and another.
<b>Drain</b>	A buried pipe or other conduit (closed drain). A ditch (open drain) for carrying off surplus surface water or groundwater.
<b>(To) Drain</b>	To provide channels, such as open ditches or closed drains, so that excess water can be removed by surface flow or by internal flow. To lose water (from the soil) by percolation.
<b>Drainage</b>	Refers to the collection, conveyance, containment, and/or discharge of surface and stormwater runoff.
<b>Drainage basin</b>	A geographic and hydrologic subunit of a watershed.
<b>Drainage channel</b>	A drainage pathway with a well-defined bed and banks indicating frequent conveyance of surface and stormwater runoff.
<b>Drainage course</b>	A pathway for watershed drainage characterized by wet soil vegetation; often intermittent in flow.
<b>Drainage easement</b>	A legal encumbrance that is placed against a property's title to reserve specified privileges for the users and beneficiaries of the drainage facilities contained within the boundaries of the easement.
<b>Drainage pathway</b>	The route that surface and stormwater runoff follows downslope as it leaves any part of the site.
<b>Drainage review</b>	An evaluation by City staff of a proposed project's compliance with the drainage requirements in this manual.



**Drainage, Soil**

As a natural condition of the soil, soil drainage refers to the frequency and duration of periods when the soil is free of saturation; for example, in well-drained soils the water is removed readily but not rapidly; in poorly drained soils the root zone is waterlogged for long periods unless artificially drained, and the roots of ordinary crop plants cannot get enough oxygen; in excessively drained soils the water is removed so completely that most crop plants suffer from lack of water. Strictly speaking, excessively drained soils are a result of excessive runoff due to steep slopes or low available water-holding capacity due to small amounts of silt and clay in the soil material. The following classes are used to express soil drainage:

- Well drained - Excess water drains away rapidly and no mottling occurs within 36 inches of the surface.
- Moderately well drained - Water is removed from the soil somewhat slowly, resulting in small but significant periods of wetness. Mottling occurs between 18 and 36 inches.
- Somewhat poorly drained - Water is removed from the soil slowly enough to keep it wet for significant periods but not all of the time. Mottling occurs between 8 and 18 inches.
- Poorly drained - Water is removed so slowly that the soil is wet for a large part of the time. Mottling occurs between 0 and 8 inches.
- Very poorly drained - Water is removed so slowly that the water table remains at or near the surface for the greater part of the time. There may also be periods of surface ponding. The soil has a black to gray surface layer with mottles up to the surface.

**Drawdown**

Lowering of the water surface (in open channel flow), water table or piezometric surface (in groundwater flow) resulting from a withdrawal of water.

**Dripline**

The area on the ground below the tree in which the boundary is designated by an imaginary line defined by the edge of the tree's branch spread.

**Drop-inlet spillway**

Overall structure in which the water drops through a vertical riser connected to a discharge conduit.

**Drop spillway**

Overall structure in which the water drops over a vertical wall onto an apron at a lower elevation.

**Drop structure**

A structure for dropping water to a lower level and dissipating its surplus energy; a fall. A drop may be vertical or inclined.

<b>Drywell</b>	An underground structure that disposes unwanted water. A drywell receives water from entry pipes located at the top of the facility. Typically, drywells are deeper than they are wide and they typically do not contain perforated pipe to distribute water evenly.
<b>Earth material</b>	Any rock, natural soil or fill and/or any combination thereof. Earth material shall not be considered topsoil used for landscape purposes. Topsoil used for landscaped purposes shall comply with ASTM D 5268 specifications. Engineered soil/landscape systems are also defined independently.
<b>Easement</b>	The legal right to use a parcel or portion of land for a particular purpose. It does not include fee ownership, but may restrict the owners use of the land.
<b>Effective Impervious Surface</b>	Those impervious surfaces that are connected via sheet flow or discrete conveyance to a drainage system. Impervious surfaces are considered ineffective if: <ul style="list-style-type: none"><li>• The runoff is dispersed through at least 100 feet of native vegetation in accordance with BMP L614 – Full Dispersion, or</li><li>• Residential Roof Runoff is infiltrated in accordance with BMPL602: Downspout Full Infiltration Systems, or</li><li>• Approved continuous runoff modeling methods indicate that the entire runoff file is infiltrated.</li></ul>
<b>Embankment</b>	A structure of earth, gravel, or similar material raised to form a pond bank or foundation for a road.
<b>Emergent plants</b>	Aquatic plants that are rooted in the sediment but whose leaves are at or above the water surface. These wetland plants often have high habitat value for wildlife and waterfowl, and can aid in pollutant uptake.
<b>Emergency spillway</b>	A vegetated earth channel used to safely convey flood discharges in excess of the capacity of the principal spillway.
<b>Emerging technology</b>	Stormwater treatment technologies that are currently being evaluated for performance or have been evaluated for performance and have achieved a use level designation following the Technology Assessment Protocol – Ecology (TAPE).
<b>Energy dissipater</b>	Any means by which the total energy of flowing water is reduced. In stormwater design, they are usually mechanisms that reduce velocity prior to, or at, discharge from an outfall in order to prevent erosion. They include rock splash pads, drop manholes, concrete stilling basins or baffles, and check dams.
<b>Energy gradient</b>	The slope of the specific energy line (i.e., the sum of the potential and velocity heads).

<b>Engineer of Record</b>	The licensed professional engineer who seals the final engineering specifications, reports, drawings, plans, design information, and calculations.
<b>Engineered soil/landscape system</b>	<p>This is a self-sustaining soil and plant system that simultaneously supports plant growth, soil microbes, water infiltration, nutrient and pollutant adsorption, sediment and pollutant biofiltration, water interflow, and pollution decomposition. The system shall be protected from compaction and erosion. The system shall be planted and/or mulched as part of the installation.</p> <p>The engineered soil/plant system shall have the following characteristics:</p> <ul style="list-style-type: none"> <li>• Be protected from compaction and erosion.</li> <li>• Have a plant system to support a sustained soil quality.</li> <li>• Possess permeability characteristics of not less than 6.0, 2.0, and 0.6 inches/hour for hydrologic soil groups A, B, and C, respectively (per ASTM D 3385). D is less than 0.6 inches/hour.</li> <li>• Possess minimum percent organic matter of 12, 14, 16, and 18 percent (dry-weight basis) for hydrologic soil groups A, B, C, and D, respectively (per ASTM D 2974).</li> </ul>
<b>Engineering geology</b>	The application of geologic knowledge and principles in the investigation and evaluation of naturally occurring rock and soil for use in the design of civil works.
<b>Engineering plan</b>	A plan prepared and stamped by a professional civil engineer.
<b>Enhancement</b>	To raise value, desirability, or attractiveness of an environment associated with surface water.
<b>Environmental Impact Statement (EIS)</b>	A document that discusses the likely significant adverse impacts of a proposal, ways to lessen the impacts, and alternatives to the proposal. They are required by the national and state environmental policy acts when projects are determined to have significant environmental impact.
<b>Erodible granular soils</b>	Soil materials that are easily eroded and transported by running water, typically fine or medium grained sand with minor gravel, silt, or clay content. Such soils are commonly described as Everett or Indianola series soil types in the SCS classification. Also included are any soils showing examples of existing severe stream channel incision as indicated by unvegetated streambanks standing over two feet high above the base of the channel.

<b>Erodible or leachable materials</b>	Wastes, chemicals, or other substances that measurably alter the physical or chemical characteristics of runoff when exposed to rainfall. Examples include erodible soils that are stockpiled, uncovered process wastes, manure, fertilizers, oily substances, ashes, kiln dust, and materials that contribute to garbage dumpster leakage.
<b>Erosion</b>	<p>The wearing away of the land surface by running water, wind, ice, or other geological agents, including such processes as gravitational creep. Also, detachment and movement of soil or rock fragments by water, wind, ice, or gravity. The following terms are used to describe different types of water erosion:</p> <ul style="list-style-type: none"> <li>• <b>Accelerated erosion</b> - Erosion much more rapid than normal or geologic erosion, primarily as a result of the influence of the activities of man or, in some cases, of the animals or natural catastrophes that expose bare surfaces (e.g., overgrazing, fires).</li> <li>• <b>Geological erosion</b> - The normal or natural erosion caused by geological processes acting over long geologic periods and resulting in the wearing away of mountains, the building up of floodplains, coastal plains, etc. Synonymous with natural erosion.</li> <li>• <b>Gully erosion</b> - The erosion process whereby water accumulates in narrow channels and, over short periods, removes the soil from this narrow area to considerable depths, ranging from 1 to 2 feet to as much as 75 to 100 feet.</li> <li>• <b>Natural erosion</b> - Wearing away of the earth's surface by water, ice, or other natural agents under natural environmental conditions of climate, vegetation, etc., undisturbed by man. Synonymous with geological erosion.</li> <li>• <b>Rill erosion</b> - An erosion process in which numerous small channels only several inches deep are formed; occurs mainly on recently disturbed and exposed soils. See <u>Rill</u>.</li> <li>• <b>Sheet erosion</b> - The removal of a fairly uniform layer of soil from the land surface by runoff.</li> <li>• <b>Splash erosion</b> - The spattering of small soil particles caused by the impact of raindrops on wet soils. The loosened and spattered particles may or may not be subsequently removed by surface runoff.</li> </ul>
<b>Erosion classes (soil survey)</b>	A grouping of erosion conditions based on the degree of erosion or on characteristic patterns. Applied to accelerated erosion, not to normal, natural, or geological erosion. Four erosion classes are recognized for water erosion and three for wind erosion.

<b>Erosion and sedimentation control</b>	Any temporary or permanent measures taken to reduce erosion; control siltation and sedimentation; and ensure that sediment-laden water does not leave the site.
<b>Erosion and sediment control facility</b>	A type of drainage facility designed to hold water for a period of time to allow sediment contained in the surface and stormwater runoff directed to the facility to settle out so as to improve the quality of the runoff.
<b>Escarpment</b>	A steep face or a ridge of high land.
<b>Estuarine wetland</b>	Generally, an eelgrass bed; salt marsh; or rocky, sandflat, or mudflat intertidal area where fresh and salt water mix. (Specifically, a tidal wetland with salinity greater than 0.5 parts per thousand, usually semi-enclosed by land but with partially obstructed or sporadic access to the open ocean).
<b>Estuary</b>	An area where fresh water meets salt water, or where the tide meets the river current (e.g., bays, mouths of rivers, salt marshes and lagoons). Estuaries serve as nurseries and spawning and feeding grounds for large groups of marine life and provide shelter and food for birds and wildlife.
<b>Eutrophication</b>	Refers to the process where nutrient over-enrichment of water leads to excessive growth of aquatic plants, especially algae.
<b>Evapotranspiration</b>	The collective term for the processes of evaporation and plant transpiration by which water is returned to the atmosphere.
<b>Evergreen</b>	A tree having foliage that persists and remains green throughout the year.
<b>Excavation</b>	The mechanical removal of earth material.
<b>Exception</b>	Relief from the application of a Minimum Requirement to a project.
<b>Exfiltration</b>	The downward movement of runoff through the bottom of an infiltration BMP into the soil layer or the downward movement of water through soil.
<b>Existing site condition</b>	Actual, legally permitted land coverage of the site at the time of proposed development.
<b>FIRM</b>	See Flood Insurance Rate Map.
<b>Fertilizer</b>	Any material or mixture used to supply one or more of the essential plant nutrient elements.
<b>Field Capacity</b>	Amount of soil moisture or water content held in soil after excess water has drained away and the rate of downward movement has materially decreased.
<b>Fill</b>	A deposit of earth material placed by artificial means.

<b>Filter fabric</b>	A woven or non-woven, water-permeable material generally made of synthetic products such as polypropylene and used in stormwater management and erosion and sediment control applications to trap sediment or prevent the clogging of aggregates by fine soil particles.
<b>Filter fabric fence</b>	A temporary sediment barrier consisting of a filter fabric stretched across and attached to supporting posts and entrenched. The filter fence is constructed of stakes and synthetic filter fabric with a rigid wire fence backing where necessary for support.
<b>Filter strip</b>	A grassy area with gentle slopes that treats stormwater runoff from adjacent paved areas before it concentrates into a discrete channel or is discharged via sheet flow.
<b>Final Stabilization</b>	The establishment of a permanent vegetative cover, or equivalent permanent stabilization measures (such as riprap, gabions, permanent impervious or hard surface) which prevents erosion.
<b>Flocculation</b>	The process by which suspended colloidal or very fine particles are assembled into larger masses or floccules which eventually settle out of suspension. This process occurs naturally but can also be caused through the use of such chemicals as alum.
<b>Flood</b>	An overflow or inundation that comes from a river or any other source, including (but not limited to) streams, tides, wave action, storm drains, or excess rainfall. Any relatively high stream flow overtopping the natural or artificial banks in any reach of a stream.
<b>Flood control</b>	Methods or facilities for reducing flood flows and the extent of flooding.
<b>Flood control project</b>	A structural system installed to protect land and improvements from floods by the construction of dikes, river embankments, channels, or dams.
<b>Flood frequency</b>	The frequency with which the flood of interest may be expected to occur at a site in any average interval of years. Frequency analysis defines the "n-year flood" as being the flood that will, over a long period of time, be equaled or exceeded on the average once every "n" years.
<b>Flood fringe</b>	That portion of the floodplain outside of the floodway which is covered by floodwaters during the base flood; it is generally associated with slower moving or standing water rather than rapidly flowing water.
<b>Flood hazard areas</b>	Those areas subject to inundation by the base flood. Includes, but is not limited to streams, lakes, wetlands, and closed depressions.

<b>Flood Insurance Rate Map (FIRM)</b>	The official map on which the Federal Emergency Management Agency has delineated many areas of flood hazard, floodway, and the risk premium zones.
<b>Flood Insurance Study</b>	The official report provided by the Federal Emergency Management Agency that includes flood profiles and the FIRM.
<b>Flood peak</b>	The highest value of the stage or discharge attained by a flood; thus, peak stage or peak discharge.
<b>Floodplain</b>	The total area subject to inundation by a flood including the flood fringe and floodway.
<b>Flood-proofing</b>	Adaptations that ensure a structure is substantially impermeable to the passage of water below the flood protection elevation that resists hydrostatic and hydrodynamic loads and effects of buoyancy.
<b>Flood protection elevation</b>	The base flood elevation or higher as defined by the local government.
<b>Flood protection facility</b>	Any levee, berm, wall, enclosure, raise bank, revetment, constructed bank stabilization, or armoring, that is commonly recognized by the community as providing significant protection to a property from inundation by flood waters.
<b>Flood routing</b>	An analytical technique used to compute the effects of system storage dynamics on the shape and movement of flow represented by a hydrograph.
<b>Flood stage</b>	The stage at which overflow of the natural banks of a stream begins.
<b>Floodway</b>	The channel of the river or stream and those portions of the adjoining floodplains that are reasonably required to carry and discharge the base flood flow. The portions of the adjoining floodplains which are considered to be "reasonably required" is defined by flood hazard regulations.
<b>Flow control facility</b>	A drainage facility designed to mitigate the impacts of increased surface and stormwater runoff flow rates generated by development. Flow control facilities are designed either to hold water for a considerable length of time and then release it by evaporation, plant transpiration, and/or infiltration into the ground, or to hold runoff for a short period of time, releasing it to the conveyance system at a controlled rate.
<b>Flow duration</b>	The aggregate time that peak flows are at or above a particular flow rate of interest. For example, the amount of time that peak flows are at or above 50% of the 2-year peak flow rate for a period of record.

<b>Flow frequency</b>	The inverse of the probability that the flow will be equaled or exceeded in any given year (the exceedance probability). For example, if the exceedance probability is 0.01 or 1 in 100, that flow is referred to as the 100-year flow.
<b>Flowpath</b>	The route that stormwater runoff follows between two points of interest.
<b>Forebay</b>	An easily maintained, extra storage area provided near an inlet of a BMP to trap incoming sediments before they accumulate in a pond or wetland BMP.
<b>Forest practice</b>	Any activity conducted on or directly pertaining to forest land and relating to growing, harvesting, or processing timber, including but not limited to: <ul style="list-style-type: none"> <li>• Road and trail construction.</li> <li>• Harvesting, final and intermediate.</li> <li>• Precommercial thinning.</li> <li>• Reforestation.</li> <li>• Fertilization.</li> <li>• Prevention and suppression of diseases and insects.</li> <li>• Salvage of trees.</li> <li>• Brush control.</li> </ul>
<b>Forested communities (wetlands)</b>	In general terms, communities (wetlands) characterized by woody vegetation that is greater than or equal to 6 meters in height; in this manual the term applies to such communities (wetlands) that represent a significant amount of tree cover consisting of species that offer wildlife habitat and other values and advance the performance of wetland functions overall.
<b>Freeboard</b>	The vertical distance between the design water surface elevation and the elevation of the crest of the facility
<b>Frequently flooded areas</b>	The 100-year floodplain designations of the Federal Emergency Management Agency and the National Flood Insurance Program or as defined by the local government.
<b>Frequency of storm (design storm frequency)</b>	The anticipated period in years that will elapse, based on average probability of storms in the design region, before a storm of a given intensity and/or total volume will recur; thus a 10-year storm can be expected to occur on the average once every 10 years. Conveyance or facilities designed to handle flows that occur under such storm conditions would be expected to be surcharged by any storms of greater amount or intensity.



<b>Frost-heave</b>	The upward movement of soil surface due to the expansion of water stored between particles in the first few feet of the soil profile as it freezes. May cause surface fracturing of asphalt or concrete.
<b>Fully Stabilized</b>	See Final Stabilization
<b>Function(s), (wetland)</b>	The ecological (physical, chemical, and biological) processes or attributes of a wetland without regard for their importance to society (see also values). Wetland functions include food chain support, provision of ecosystem diversity and fish and wildlife habitat, floodflow alteration, groundwater recharge and discharge, water quality improvement, and soil stabilization.
<b>Gabion</b>	A rectangular or cylindrical wire mesh cage (a chicken wire basket) filled with rock and used as a protecting agent, revetment, etc., against erosion. Soft gabions, often used in streambank stabilization, are made of geotextiles filled with dirt, in between which cuttings are placed.
<b>Gage or gauge</b>	A device for registering precipitation, water level, discharge, velocity, pressure, temperature, etc. Also, a measure of the thickness of metal; e.g., diameter of wire, wall thickness of steel pipe.
<b>Gauging station</b>	A selected section of a stream channel equipped with a gauge, recorder, or other facilities for determining stream discharge.
<b>Geologist</b>	A person who has earned a degree in geology from an accredited college or university or who has equivalent educational training and has at least five years of experience as a practicing geologist or four years of experience and at least two years post-graduate study, research or teaching. The practical experience shall include at least three years work in applied geology and landslide evaluation, in close association with qualified practicing geologists or geotechnical professional/civil engineers.
<b>Geologically hazardous areas</b>	Areas that, because of their susceptibility to erosion, sliding, earthquake, or other geological events, are not suited to the siting of commercial, residential, or industrial development consistent with public health or safety concerns.
<b>Geometrics</b>	The mathematical relationships between points, lines, angles, and surfaces used to measure and identify areas of land.
<b>Geotechnical professional civil engineer</b>	A practicing, geotechnical/civil engineer licensed as a professional Civil Engineer with the State of Washington who has at least four years of professional employment as a geotechnical engineer in responsible charge, including experience with landslide evaluation.

<b>Grade</b>	The slope of a road, channel, or natural ground. The finished surface of a canal bed, roadbed, top of embankment, or bottom of excavation; any surface prepared for the support of construction such as paving or the laying of a conduit.
<b>(To) Grade</b>	To finish the surface of a canal bed, roadbed, top of embankment or bottom of excavation.
<b>Gradient terrace</b>	An earth embankment or a ridge-and-channel constructed with suitable spacing and an acceptable grade to reduce erosion damage by intercepting surface runoff and conducting it to a stable outlet at a stable nonerosive velocity.
<b>Grassed waterway</b>	A natural or constructed waterway, usually broad and shallow, covered with erosion-resistant grasses, used to conduct surface water from an area at a reduced flow rate. See also biofilter.
<b>Groundwater</b>	Water in a saturated zone or stratum beneath the land surface or a surface waterbody.
<b>Groundwater recharge</b>	Inflow to a groundwater reservoir.
<b>Groundwater table</b>	The free surface of the groundwater, that surface subject to atmospheric pressure under the ground, generally rising and falling with the season, the rate of withdrawal, the rate of restoration, and other conditions. It is seldom static.
<b>Gully</b>	A channel caused by the concentrated flow of surface and stormwater runoff over unprotected erodible land.
<b>Habitat</b>	The specific area or environment in which a particular type of plant or animal lives. An organism's habitat must provide all of the basic requirements for life and should be protected from harmful biological, chemical, and physical alterations.
<b>Hardpan</b>	A cemented or compacted and often clay-like layer of soil that is impenetrable by roots. Also known as glacial till.
<b>Hard Surface</b>	An impervious surface, a permeable pavement or a vegetated roof.
<b>Harmful pollutant</b>	A substance that has adverse effects to an organism including immediate death, impaired reproduction, cancer or other effects.
<b>Head (hydraulics)</b>	The height of water above any plane of reference. The energy, either kinetic or potential, possessed by each unit weight of a liquid, expressed as the vertical height through which a unit weight would have to fall to release the average energy possessed. Used in various compound terms such as pressure head, velocity head, and head loss.

<b>Head loss</b>	Energy loss due to friction, eddies, changes in velocity, or direction of flow.
<b>Heavy metals</b>	Metals of high specific gravity, present in municipal and industrial wastes, that pose long-term environmental hazards. Such metals include cadmium, chromium, cobalt, copper, lead, mercury, nickel, and zinc.
<b>High-use site</b>	<p>High-use sites are those that typically generate high concentrations of oil due to high traffic turnover or the frequent transfer of oil. High-use sites include:</p> <ul style="list-style-type: none"> <li>• An area of a commercial or industrial site subject to an expected average daily traffic (ADT) count equal to or greater than 100 vehicles per 1,000 square feet of gross building area;</li> <li>• An area of a commercial or industrial site subject to petroleum storage and transfer in excess of 1,500 gallons per year, not including routinely delivered heating oil;</li> <li>• An area of a commercial or industrial site subject to parking, storage or maintenance of 25 or more vehicles that are over 10 tons gross weight (trucks, buses, trains, heavy equipment, etc.);</li> <li>• A road intersection with a measured ADT count of 25,000 vehicles or more on the main roadway and 15,000 vehicles or more on any intersecting roadway, excluding projects proposing primarily pedestrian or bicycle use.</li> </ul>
<b>Highway</b>	A main public road connecting towns and cities.
<b>Hog fuel</b>	See wood-based mulch.
<b>Horton overland flow</b>	A runoff process whereby the rainfall rate exceeds the infiltration rate, so that the precipitation that does not infiltrate flows downhill over the soil surface.
<b>HSPF</b>	<b>Hydrological Simulation Program-Fortran.</b> A continuous simulation hydrologic model that transforms an uninterrupted rainfall record into a concurrent series of runoff or flow data by means of a set of mathematical algorithms which represent the rainfall-runoff process at some conceptual level.
<b>Humus</b>	Organic matter in or on a soil, composed of partly or fully decomposed bits of plant tissue or from animal manure.
<b>Hydraulic Conductivity</b>	The quality of saturated soil that enables water or air to move through it. Also known as permeability coefficient.
<b>Hydraulic gradient</b>	Slope of the potential head relative to a fixed datum.
<b>Hydrodynamics</b>	The dynamic energy, force, or motion of fluids as affected by the physical forces acting upon those fluids.

<b>Hydrograph</b>	A graph of runoff rate, inflow rate or discharge rate, past a specific point over time.
<b>Hydrologic cycle</b>	The circuit of water movement from the atmosphere to the earth and return to the atmosphere through various stages or processes as precipitation, interception, runoff, infiltration, percolation, storage, evaporation, and transpiration.
<b>Hydrologic Soil Groups</b>	<p>A soil characteristic classification system defined by the U.S. Soil Conservation Service in which a soil may be categorized into one of four soil groups (A, B, C, or D) based upon infiltration rate and other properties.</p> <p><b>Type A:</b> Low runoff potential. Soils having high infiltration rates, even when thoroughly wetted, and consisting chiefly of deep, well drained to excessively drained sands or gravels. These soils have a high rate of water transmission.</p> <p><b>Type B:</b> Moderately low runoff potential. Soils having moderate infiltration rates when thoroughly wetted, and consisting chiefly of moderately fine to moderately coarse textures. These soils have a moderate rate of water transmission.</p> <p><b>Type C:</b> Moderately high runoff potential. Soils having slow infiltration rates when thoroughly wetted, and consisting chiefly of soils with a layer that impedes downward movement of water, or soils with moderately fine to fine textures. These soils have a slow rate of water transmission.</p> <p><b>Type D:</b> High runoff potential. Soils having very slow infiltration rates when thoroughly wetted, and consisting chiefly of clay soils with a high swelling potential, soils with a permanent high water table, soils with a hardpan, till, or clay layer at or near the surface, soils with a compacted subgrade at or near the surface, and shallow soils or nearly impervious material. These soils have a very slow rate of water transmission.<sup>1</sup></p> <p><sup>1</sup> Vladimir Novotny and Harvey Olem. <i>Water Quality Prevention, Identification, and Management of Diffuse Pollution</i>, Van Nostrand Reinhold: New York, 1994, p. 109.</p>
<b>Hydrology</b>	The science of the behavior of water in the atmosphere, on the surface of the earth, and underground.
<b>Hydroperiod</b>	A seasonal occurrence of flooding and/or soil saturation; it encompasses depth, frequency, duration, and seasonal pattern of inundation.
<b>Hyetograph</b>	A graph of percentages of total precipitation for a series of time steps representing the total time in which precipitation occurs.
<b>Illicit discharge</b>	Any discharge to the stormwater system that is not composed entirely of stormwater or of non-stormwater discharges as allowed in the Phase I NPDES Municipal Stormwater General Permit (S5.C.8, S6.D.3).

<b>Impact basin</b>	A device used to dissipate the energy of flowing water. Generally constructed of concrete in the form of a partially depressed or partially submerged vessel, it may utilize baffles to dissipate velocities.
<b>Impervious</b>	Not allowing penetration.
<b>Impervious surface</b>	A non-vegetated surface area which either prevents or retards the entry of water into the soil mantle as under natural conditions prior to development. A non-vegetated surface area which causes water to run off the surface in greater quantities or at an increased rate of flow from the flow present under natural conditions prior to development. Common impervious surfaces include, but are not limited to, rooftops, walkways, patios, driveways, parking lots or storage areas, concrete or asphalt paving, gravel roads, packed earthen materials, and oiled, macadam or other surfaces which similarly impede the natural infiltration of stormwater. Open, uncovered retention/detention facilities shall not be considered as impervious surfaces for the purposes of determining whether the thresholds for application of minimum requirements are exceeded. Open, uncovered retention/detention facilities shall be considered impervious surfaces for purposes of runoff modeling.
<b>Impoundment</b>	A natural or man-made containment for surface water.
<b>Improvement</b>	Streets (with or without curbs or gutters), sidewalks, crosswalks, parking lots, water mains, wastewater and stormwater pipes, stormwater facilities, street trees and other appropriate items.
<b>Indirect connections</b>	Stormwater discharges that do not discharge directly into a waterbody, but travel through other conveyance systems before reaching that waterbody.
<b>Industrial activities</b>	Material handling, transportation, or storage; manufacturing; maintenance; treatment; or disposal. Areas with industrial activities include plant yards, access roads and rail lines used by carriers of raw materials, manufactured products, waste material, or by-products; material handling sites; refuse sites; sites used for the application or disposal of process waste waters; sites used for the storage and maintenance of material handling equipment; sites used for residual treatment, storage, or disposal; shipping and receiving areas; manufacturing buildings; storage areas for raw materials, and intermediate and finished products; and areas where industrial activity has taken place in the past and significant materials remain and are exposed to stormwater.
<b>Industrial sites</b>	Those sites zoned industrial or with industrial activities. These include areas that manufacture, process, or store raw materials.

<b>Infiltration</b>	Means the downward movement of water from the surface to the subsoil.
<b>Infiltration facility (or system)</b>	A drainage facility designed to use the hydrologic process of surface and stormwater runoff soaking into the ground, commonly referred to as a percolation, to dispose of surface and stormwater runoff.
<b>Infiltration rate</b>	The rate, usually expressed in inches/hour, at which water moves downward (percolates) through the soil profile. Short-term infiltration rates may be inferred from soil analysis or texture or derived from field measurements. Long-term infiltration rates are affected by variability in soils and subsurface conditions at the site, the effectiveness of pretreatment or influent control, and the degree of long-term maintenance of the infiltration facility.
<b>Ingress/egress</b>	The points of access to and from a property.
<b>Inlet</b>	A form of connection between surface of the ground and a drain or sewer for the admission of surface and stormwater runoff.
<b>Insecticide</b>	A substance, usually chemical, that is used to kill insects.
<b>Integrated Pest Management (IPM)</b>	A natural, long-term ecologically based approach to controlling pest populations.
<b>Interception (Hydraulics)</b>	The process by which precipitation is caught and held by foliage, twigs, and branches of trees, shrubs, and other vegetation. Often used for "interception loss" or the amount of water evaporated from the precipitation intercepted.
<b>Interflow</b>	That portion of rainfall that infiltrates into the soil and moves laterally through the upper soil horizons until intercepted by a stream channel or until it returns to the surface for example, in a roadside ditch, wetland, spring or seep. Interflow is a function of the soil system depth, permeability, and water-holding capacity.
<b>Intermittent stream</b>	A stream or portion of a stream that flows only in direct response to precipitation. It receives little or no water from springs and no long-continued supply from melting snow or other sources. It is dry for a large part of the year, ordinarily more than three months.
<b>Invasive weedy plant species</b>	Opportunistic species of inferior biological value that tend to out-compete more desirable forms and become dominant; applied to non-native species in this manual.
<b>Invert</b>	The lowest point on the inside of a sewer or other conduit.
<b>Invert elevation</b>	The vertical elevation of the pipe invert.
<b>Isopluvial map</b>	A map with lines representing constant depth of total precipitation for a given return frequency.

<b>Lag time</b>	The interval between the center of mass of the storm precipitation and the peak flow of the resultant runoff.
<b>Lake</b>	A natural area permanently inundated by water in excess of two meters deep and greater than 20 acres in size as measured at the ordinary high water marks.
<b>Land disturbing activities</b>	Any activity that results in a change in the existing soil cover (both vegetative and non-vegetative) and/or existing soil topography. Land disturbing activities include, but are not limited to clearing, grading, filling, and excavation. Compaction that is associated with stabilization of structures and road construction shall also be considered a land disturbing activity. Vegetation maintenance practices, including landscape maintenance and gardening, are not considered land disturbing activity if conducted according to established standards and procedures. Stormwater facility maintenance is not considered land disturbing activity if conducted according to established standards and procedures.
<b>Landscaped Areas</b>	Vegetation, including but not limited to, annuals, woody and herbaceous perennials such as shrubs, vines, or trees that are regularly and/or systematically maintained through a combination of pruning, mowing, watering, trimming, fertilizing, and other activities. Landscaped areas are typically used for aesthetic purposes.
<b>Landslide</b>	Episodic downslope movement of a mass of soil or rock that includes but is not limited to rockfalls, slumps, mudflows, and earthflows. For the purpose of these rules, snow avalanches are considered to be a special case of landsliding.
<b>Landslide hazard areas</b>	Those areas subject to a severe risk of landslide.
<b>Lawn Areas</b>	An area of land planted with grasses or other durable plants which are maintained at a short height and used for aesthetic and/or recreational purposes. The definition also includes turf surfaces, artificial lawn surfaces, and artificial turf surfaces.
<b>Leachable materials</b>	Those substances that, when exposed to rainfall, measurably alter the physical or chemical characteristics of the rainfall runoff. Examples include erodible soils, uncovered process wastes, manure, fertilizers, oil substances, ashes, kiln dust, and materials contributing to garbage dumpster leakage.
<b>Leachate</b>	Any liquid that in passing through matter, extracts solutes, suspended solids or any other component of the material through which it has passed.
<b>Leaching</b>	Removal of the more soluble materials from the soil or other material by percolating waters.

<b>Legume</b>	A member of the legume or pulse family, <u>Leguminosae</u> , one of the most important and widely distributed plant families. The fruit is a "legume" or pod. Includes many valuable food and forage species, such as peas, beans, clovers, alfalfas, sweet clovers, and vetches. Practically all legumes are nitrogen-fixing plants.
<b>Level pool routing</b>	The basic technique of storage routing used for sizing and analyzing detention storage and determining water levels for ponding water bodies. The level pool routing technique is based on the continuity equation: $\text{Inflow} - \text{Outflow} = \text{Change in storage}$ .
<b>Level spreader</b>	A device used to spread out stormwater runoff uniformly over the ground surface as sheet flow (i.e., not through channels). The purpose of level spreaders is to prevent concentrated, erosive flows from occurring, and to enhance infiltration.
<b>Local government</b>	Any county, city, town, or special purpose district having its own incorporated government for local affairs.
<b>Low flow channel</b>	An incised or paved channel from inlet to outlet in a dry basin which is designed to carry low runoff flows and/or baseflow, directly to the outlet without detention.
<b>Low impact development</b>	A stormwater and land use management strategy that strives to mimic predisturbance hydrologic processes of infiltration, filtration, storage, evaporation and transpiration by emphasizing conservation, use of onsite natural features, site planning, and distributed stormwater management practices that are integrated into a project design.
<b>Low Impact Development Best Management Practices (LID BMPs)</b>	Distributed stormwater management practices, integrated into a project design, that emphasize predisturbance hydrologic processes of infiltration, filtration, storage, evaporation and transpiration. LID BMPs include, but are not limited to, bioretention, rain gardens, permeable pavements, roof downspout infiltration and dispersion, dispersion, soil quality and depth, minimal excavation foundations, vegetated roofs, and water reuse.
<b>Low Impact Development Principles</b>	Land use management strategies that emphasize conservation, use of onsite natural features, and site planning to minimize impervious surfaces, native vegetation loss and stormwater runoff.
<b>Low permeability liner</b>	A layer of compacted till, compacted clay, concrete, or a geomembrane.



<b>Lowest floor</b>	The lowest enclosed area (including basement) of a structure. An area used solely for parking of vehicles, building access, or storage, in an area other than a basement area, is not considered a building's lowest floor, provided that the enclosed area meets all of the structural requirements of the flood hazard standards.
<b>MDNS</b>	A Mitigated Determination of Nonsignificance (See DNS and Mitigation).
<b>Maintenance</b>	<p>Repair and maintenance includes activities conducted on currently serviceable structures, facilities, and equipment that involves no expansion or use beyond that previously existing and resulting in no significant adverse hydrologic impact. It includes those usual activities taken to prevent a decline, lapse, or cessation in the use of structures and systems and includes replacement of dysfunctioning facilities, including cases where environmental permits require replacing an existing structure with a different type structure, as long as the functioning characteristics of the original structure are not changed. For example, replacing a collapsed, fish blocking, round culvert with a new box culvert under the same span, or width, of roadway.</p> <p>For stormwater facilities, maintenance includes assessment to ensure ongoing proper operation, removal of built up pollutants (i.e., sediments), replacement of failed or failing treatment media, and other actions taken to correct deficits as identified in the maintenance standards, Volume 1, Appendix C. See exemptions for Pavement Maintenance, Volume 1, Section 3.2.</p>
<b>Manning's equation</b>	<p>An equation used to predict the velocity of water flow in an open channel or pipelines:</p> $V = \frac{1.486R^{2/3}S^{1/2}}{n}$ <p>where:</p> <p>V is the mean velocity of flow in feet per second</p> <p>R is the hydraulic radius in feet</p> <p>S is the slope of the energy gradient or, for assumed uniform flow, the slope of the channel in feet per foot; and</p> <p>n is Manning's roughness coefficient or retardance factor of the channel lining.</p>
<b>Mass wasting</b>	The movement of large volumes of earth material downslope.
<b>Master drainage plan</b>	A comprehensive drainage control plan intended to prevent significant adverse impacts to the natural and manmade drainage system, both on and off-site.

<b>Mature tree</b>	A tree that has achieved at least 75% of its full canopy growth or a tree that is over 15 years of age.
<b>Mature tree spread</b>	Crown diameter at maturity.
<b>Maximum Extent Practicable (MEP)</b>	Refers to paragraph 402(p)(3)(B)(iii) of the federal Clean Water Act which reads as follows: Permits for discharges from municipal storm sewers shall require controls to reduce the discharge of pollutants to the maximum extent practicable, including management practices, control techniques, and system design and engineering methods, and other such provisions as the Administrator or the State determines appropriate for the control of such pollutants.
<b>Mean annual water level fluctuation</b>	Derived as follows: <ol style="list-style-type: none"> <li>1. Measure the maximum water level (e.g., with a crest stage gage, Reinelt and Horner 1990) and the existing water level at the time of the site visit (e.g., with a staff gage) on at least eight occasions spread through a year.</li> <li>2. Take the difference of the maximum and existing water level on each occasion and divide by the number of occasions.</li> </ol>
<b>Mean depth</b>	Average depth; cross-sectional area of a stream or channel divided by its surface or top width.
<b>Mean velocity</b>	The average velocity of a stream flowing in a channel or conduit at a given cross-section or in a given reach. It is equal to the discharge divided by the cross-sectional area of the reach.
<b>Measuring weir</b>	A shaped notch through which water flows are measured. Common shapes are rectangular, trapezoidal, and triangular.
<b>Mechanical analysis</b>	The analytical procedure by which soil particles are separated to determine the particle size distribution.
<b>Mechanical practices</b>	Soil and water conservation practices that primarily change the surface of the land or that store, convey, regulate, or dispose of runoff water without excessive erosion.
<b>Metals</b>	Elements, such as mercury, lead, nickel, zinc and cadmium, which are of environmental concern because they do not degrade over time. Although many are necessary nutrients, they are sometimes magnified in the food chain, and they can be toxic to life in high enough concentrations. They are also referred to as heavy metals.

<b>Microbes</b>	The lower trophic levels of the soil food web. They are normally considered to include bacteria, fungi, flagellates, amoebae, ciliates, and nematodes. These in turn support the higher trophic levels, such as mites and earthworms. Together they are the basic life forms that are necessary for plant growth. Soil microbes also function to bioremediate pollutants such as petroleum, nutrients, and pathogens.
<b>Mitigation</b>	To lessen known impacts to the environment. Mitigation should be conducted in the following order of preference: <ol style="list-style-type: none"> <li>1. Avoiding the impact altogether by not taking a certain action or part of an action;</li> <li>2. Minimizing impacts by limiting the degree or magnitude of the action and its implementation, by using appropriate technology, or by taking affirmative steps to avoid or reduce impacts;</li> <li>3. Rectifying the impact by repairing, rehabilitating or restoring the affected environment;</li> <li>4. Reducing or eliminating the impact over time by preservation and maintenance operations during the life of the action; and</li> <li>5. Compensating for the impact by replacing, enhancing, or providing substitute resources or environments.</li> </ol>
<b>Modification, modified (wetland)</b>	A wetland whose physical, hydrological, or water quality characteristics have been purposefully altered for a management purpose, such as by dredging, filling, forebay construction, and inlet or outlet control.
<b>Monitor</b>	To systematically and repeatedly measure something in order to track changes.
<b>Monitoring</b>	The collection of data by various methods for the purposes of understanding natural systems and features, evaluating the impacts of development proposals on such systems, and assessing the performance of mitigation measures imposed as conditions of development.

<b>Mulch</b>	<p>A layer of organic material or aggregate applied to the surface of soil. Its purpose is any or all of the following:</p> <ul style="list-style-type: none"> <li>• To conserve soil moisture or temperature</li> <li>• To improve the fertility and health of the soil</li> <li>• To reduce weed growth</li> <li>• To hold fertilizer, seed, and soil in place.</li> <li>• To enhance aesthetics of the facility.</li> </ul> <p>Types of mulch include: chipped site vegetation, compost, hydromulch, wood-based mulch or wood straw, wood strand, straw, and aggregate.</p>
<b>Multifamily sites</b>	Sites defined as multifamily in TMC 13.06.
<b>NGVD</b>	National Geodetic Vertical Datum.
<b>National Pollutant Discharge Elimination System (NPDES)</b>	The part of the federal Clean Water Act, which requires point source dischargers to obtain permits. These permits are referred to as NPDES permits and, in Washington State, are administered by the Washington State Department of Ecology.
<b>Native Growth Protection Easement (NGPE)</b>	An easement granted for the protection of native vegetation within a sensitive area or its associated buffer. The NGPE shall be recorded on the appropriate documents of title and filed with the County Assessor.
<b>Native vegetation</b>	Vegetation comprised of plant species, other than noxious weeds, that are indigenous to the coastal region of the Pacific Northwest and which reasonably could have been expected to naturally occur on the site. Examples include trees such as Douglas fir, Western Hemlock, Western Red Cedar, Alder, Big-leaf Maple, and Vine Maple; shrubs such as willow, elderberry, salmonberry and salal; and herbaceous plants such as sword fern, foam flower, and fireweed.
<b>Natural Area</b>	Land on which the existing plants arose naturally, or were planted intentionally to mimic natural processes.
<b>Natural location</b>	The location of those channels, swales, and other non-manmade conveyance systems as defined by the first documented topographic contours existing for the subject property, either from maps or photographs, or such other means as appropriate. Based upon site geology and the infiltration capability of the underlying soils, there may be no discernible surface discharge.

**New development**

- Land Disturbing Activities, including Class IV – general forest practices that are conversions from timber land to other uses
- Structural development, including construction or installation of a building or other structure.
- Creation of hard surfaces
- Subdivision, short subdivision, and binding site plans as defined and applied in Chapter 58.17 RCW.

Projects meeting the definition of redevelopment shall not be considered new development

**New Hard Surface**

A newly created impervious surface, permeable pavement, or vegetated roof.

On redevelopment sites, the expansion of a structure over an existing impervious asphalt or concrete surface will not be considered replaced impervious surfaces and will not count toward project thresholds. See exemptions for Pavement Maintenance, Volume 1, Section 3.2.

**New Impervious Surface**

A newly created impervious surface. Creation of an impervious surface shall include:

- Construction of buildings
- Construction of structures
- Construction of new hard surfaces

For pavements:

- Extending the pavement edge without increasing the size of the road prism
- Paving gravel shoulders
- Upgrading from dirt to gravel, asphalt, or concrete
- Upgrading from gravel to asphalt or concrete
- Upgrading from bituminous surface treatment (“chip seal”) to asphalt or concrete.

On redevelopment sites the following apply:

For structures, the construction of a structure over an existing impervious asphalt or concrete surface will not be considered new or replaced impervious surfaces and will not be counted toward project thresholds if the existing underlying surface remains in place and the existing underlying surface is not a foundation. Construction of a structure over an existing foundation will be considered a replaced impervious surface per the definition of Replaced Impervious Surface.

Asphalt or concrete overlays will not be considered a new or replaced impervious surface and will not be counted toward project thresholds. If non-porous asphalt or concrete is laid over existing permeable pavements, the asphalt or concrete will be considered a new impervious surface and the stormwater mitigation provided by the existing permeable surface shall be replaced.

**Nitrate (NO<sub>3</sub>)**

A form of nitrogen which is an essential nutrient to plants. It can cause algal blooms in water if all other nutrients are present in sufficient quantities. It is a product of bacterial oxidation of other forms of nitrogen, from the atmosphere during electrical storms and from fertilizer manufacturing.

**Nitrification**

The biochemical oxidation process by which ammonia is changed first to nitrites and then to nitrates by bacterial action, consuming oxygen in the water.

**Nitrogen, Available**

Usually ammonium, nitrite, and nitrate ions, and certain simple amines available for plant growth. A small fraction of organic or total nitrogen in the soil is available at any time.

**Nonpoint source pollution**

Pollution that enters a waterbody from diffuse origins on the watershed and does not result from discernible, confined, or discrete conveyances.

<b>Normal depth</b>	The depth of uniform flow. This is a unique depth of flow for any combination of channel characteristics and flow conditions. Normal depth is calculated using Manning's Equation.
<b>NRCS Method</b>	A single-event hydrologic analysis technique for estimating runoff based on the Curve Number method. The Curve Numbers are published by NRCS in Technical Release No. 55: Urban Hydrology for Small Watersheds, 1986. This method is also known as the SCS method (the Soil Conservation Service changed names in 1994 to the Natural Resources Conservation Services).
<b>Nutrients</b>	Essential chemicals needed by plants or animals for growth. Excessive amounts of nutrients can lead to degradation of water quality and algal blooms. Some nutrients can be toxic at high concentrations.
<b>Off-line facilities</b>	Stormwater facilities to which stormwater runoff is restricted to some maximum flow rate or volume by a flow-splitter.
<b>Offsite</b>	Any area lying upstream of the site that drains onto the site and any area lying downstream of the site to which the site drains.
<b>Off-system storage</b>	Facilities for holding or retaining excess flows over and above the carrying capacity of the stormwater conveyance system, in chambers, tanks, lagoons, ponds, or other basins that are not a part of the subsurface stormwater system.
<b>Oil Mat</b>	A surface treatment that creates a permanent unyielding non-skid roadway similar to asphalt or concrete and is considered a City of Tacoma Standard Roadway Design. When overlaying an oil mat surface with asphalt or concrete, the surface will not be considered a new or replaced surface and will not count toward the project thresholds. See Volume 1, Section 3.2.1 for Pavement Maintenance Exemptions.
<b>Oil/water separator</b>	A vault, usually underground, designed to provide a quiescent environment to separate oil from water.
<b>On-line facilities</b>	Stormwater facilities which receive all of the stormwater runoff from a drainage area. Flows above the water quality design flow rate or volume are passed through at a lower percent removal efficiency.
<b>Onsite</b>	The entire property that includes any proposed development.
<b>Onsite Stormwater Management BMPs</b>	Best management practices intended to manage stormwater runoff onsite where feasible.

<b>Operational BMPs</b>	Operational BMPs are a type of Source Control BMP. They are schedules of activities, prohibition of practices, and other managerial practices to prevent or reduce pollutants from entering stormwater. Operational BMPs include formation of a pollution prevention team, good housekeeping, preventive maintenance procedures, spill prevention and clean-up, employee training, inspections of pollutant sources and BMPs, and record keeping. They can also include process changes, raw material/product changes, and recycling wastes.
<b>Ordinary high water mark</b>	<p>The term ordinary high water mark means the line on the shore established by the fluctuations of water and indicated by physical characteristics such as a clear, natural line impressed on the bank; shelving; changes in the character of soil destruction on terrestrial vegetation, or the presence of litter and debris; or other appropriate means that consider the characteristics of the surrounding area.</p> <p>The ordinary high water mark will be found by examining the bed and banks of a stream and ascertaining where the presence and action of waters are so common and usual, and so long maintained in all ordinary years, as to mark upon the soil a character distinct from that of the abutting upland, in respect to vegetation. In any area where the ordinary high water mark cannot be found, the line of mean high water shall substitute. In any area where neither can be found, the channel bank shall be substituted. In braided channels and alluvial fans, the ordinary high water mark or substitute shall be measured so as to include the entire stream feature.</p>
<b>Organic matter</b>	Organic matter as decomposed animal or vegetable matter. It is measured by ASTM D 2974. Organic matter is an important reservoir of carbon and a dynamic component of soil and the carbon cycle. It improves soil and plant efficiency by improving soil physical properties including drainage, aeration, and other structural characteristics. It contains the nutrients, microbes, and higher-form soil food web organisms necessary for plant growth. The maturity of organic matter is a measure of its beneficial properties. Raw organic matter can release water-soluble nutrients (similar to chemical fertilizer). Beneficial organic matter has undergone a humification process either naturally in the environment or through a composting process.
<b>Orifice</b>	An opening with closed perimeter, usually sharp-edged, and of regular form in a plate, wall, or partition through which water may flow, generally used for the purpose of measurement or control of water.



<b>Outfall</b>	A point source as defined by 40 CFR 122.2 at the point where a discharge leaves the Permittee's MS4 and enters a surface receiving waterbody or surface receiving waters. Outfall does not include pipes, tunnels, or other conveyances which connect segments of the same stream or other surface waters and are used to convey primarily surface waters (i.e., culverts).
<b>Outlet</b>	Point of water disposal from a stream, river, lake, tidewater, or artificial drain.
<b>Outlet channel</b>	A waterway constructed or altered primarily to carry water from man-made structures, such as terraces, tile lines, and diversions.
<b>Outwash soils</b>	Soils formed from highly permeable sands and gravels.
<b>Overflow</b>	A channel or device that allows that portion of flow above the design flowrate to discharge downstream.
<b>Overlay</b>	Placement of an additional layer of asphalt or concrete over existing asphalt or concrete. An overlay can be done when the existing asphalt or concrete is in overall good condition with minor problem areas (e.g, severe cracking, crumbling, sinking, or wavy).
<b>Overtopping</b>	To flow over the limits of a containment or conveyance element.
<b>Particle Size</b>	The effective diameter of a particle as measured by sedimentation, sieving, or micrometric methods.
<b>Pasture</b>	Land (typically grass) used for domestic grazing animals.
<b>Pavement Preservation</b>	A program employing a network level, long-term strategy that enhances pavement performance by using an integrated, cost-effective set of practices that extend pavement life, improve safety and meet motorist expectations. Pavement preservation includes pavement maintenance activities (such as crack sealing, chip sealing, concrete joint sealing), minor rehabilitation activities (such as grind and overlay, overlay), and routine or corrective maintenance activities (such as pothole patching, square patching, overlays, maintenance of pavement markings).
<b>Peak discharge</b>	The maximum instantaneous rate of flow during a storm, usually in reference to a specific design storm event.
<b>Percolation</b>	The movement of water through soil.
<b>Percolation rate</b>	The rate, often expressed in minutes/inch, at which clear water, maintained at a relatively constant depth, will seep out of a standardized test hole that has been previously saturated. The term percolation rate is often used synonymously with infiltration rate (short-term infiltration rate).

<b>Permanent Stormwater Control (PSC) Plan</b>	A plan which includes permanent BMPs for the control of pollution from stormwater runoff after construction and/or land disturbing activity has been completed.
<b>Permeable pavement</b>	Pervious concrete, porous asphalt, permeable pavers or other forms of pervious or porous paving material intended to allow passage of water through the pavement section. It often includes an aggregate base that provides structural support and acts as a stormwater reservoir.
<b>Permeable soils</b>	Soil materials with a sufficiently rapid infiltration rate so as to greatly reduce or eliminate surface and stormwater runoff. These soils are generally classified as SCS hydrologic soil types A and B.
<b>Person</b>	Any individual, partnership, corporation, association, organization, cooperative, public or municipal corporation, agency of the state, or local government unit, however designated.
<b>Pervious surface</b>	Any surface material that allows stormwater to infiltrate into the ground. Examples include lawn, landscape, pasture, native vegetation areas, and permeable pavements.
<b>Perviousness</b>	Related to the size and continuity of void spaces in soils; related to a soil's infiltration rate.
<b>Pesticide</b>	A general term used to describe any substance - usually chemical - used to destroy or control organisms; includes herbicides, insecticides, algicides, fungicides, and others. Many of these substances are manufactured and are not naturally found in the environment. Others, such as pyrethrum, are natural toxins that are extracted from plants and animals.
<b>pH</b>	A measure of the alkalinity or acidity of a substance which is conducted by measuring the concentration of hydrogen ions in the substance. A pH of 7.0 indicates neutral water. A 6.5 reading is slightly acid.
<b>Physiographic</b>	Characteristics of the natural physical environment (including hills).
<b>Plan Approval Authority</b>	The Plan Approval Authority is defined as that department within a local government that has been delegated authority to approve stormwater site plans.
<b>Planned unit development (PUD)</b>	A special classification authorized in some zoning ordinances, where a unit of land under control of a single developer may be used for a variety of uses and densities, subject to review and approval by the local governing body. The locations of the zones are usually decided on a case-by-case basis.

<b>Plat</b>	A map or representation of a subdivision showing the division of a tract or parcel of land into lots, blocks, streets, or other divisions and dedications.
<b>Plunge pool</b>	A device used to dissipate the energy of flowing water that may be constructed or made by the action of flowing. These facilities may be protected by various lining materials.
<b>Point discharge</b>	The release of collected and/or concentrated surface and stormwater runoff from a pipe, culvert, or channel.
<b>Point of compliance</b>	The location at which compliance with a discharge performance standard or a receiving water quality standard is measured.
<b>Pollution</b>	Contamination or other alteration of the physical, chemical, or biological properties, of waters of the state, including change in temperature, taste, color, turbidity, or odor of the waters, or such discharge of any liquid, gaseous, solid, radioactive or other substance into any waters of the state as will or is likely to create a nuisance or render such waters harmful, detrimental or injurious to the public health, safety or welfare, or to domestic, commercial, industrial, agricultural, recreational, or other legitimate beneficial uses, or to livestock, wild animals, birds, fish or other aquatic life.
<b>Pollution-generating hard surface (PGHS)</b>	Those hard surfaces considered to be a significant source of pollutants in stormwater runoff. PGHS includes permeable pavement subject to vehicular use. See the listing of surfaces under pollution generating impervious surfaces.
<b>Pollution-generating impervious surface (PGIS)</b>	Those impervious surfaces considered to be a significant source of pollutants in stormwater runoff. Such surfaces include: <ul style="list-style-type: none"> <li>• those which are subject to vehicular use (further defined in the glossary);</li> <li>• those which are subject to industrial activities (further defined in the glossary);</li> <li>• those which are subject to storage of erodible or leachable materials, wastes, or chemicals, and which receive direct rainfall or the runoff or blow-in of rainfall;</li> <li>• metal roofs unless they are coated with an inert, non-leachable material;</li> <li>• roof that are subject to venting significant amounts of dusts, mists, or fumes from manufacturing, commercial, or other indoor activities.</li> </ul>

<b>Pollution-generating pervious surface (PGPS)</b>	<p>Any non-impervious surface subject to:</p> <ul style="list-style-type: none"> <li>• vehicular use;</li> <li>• industrial activities (as further defined in the glossary);</li> <li>• storage of erodible or leachable materials, wastes, or chemicals, and which receive direct rainfall or the runoff or blow-in of rainfall;</li> <li>• use of pesticides and fertilizers; or</li> <li>• loss of soil.</li> </ul> <p>Typical PGPS include lawns and landscaped areas including: golf courses, parks, cemeteries, and sports fields (natural and artificial turf).</p>
<b>Predeveloped Condition</b>	<p>The native vegetation and soils that existed at a site prior to the influence of Euro-American settlement. The pre-developed condition shall be assumed to be forested land cover unless reasonable, historic information is provided that indicates the site was prairie prior to settlement.</p>
<b>Prediction</b>	<p>For the purposes of this document an expected outcome based on the results of hydrologic modeling and/or the judgment of a trained professional civil engineer or geologist.</p>
<b>Pretreatment</b>	<p>The removal of material such as solids, grit, grease, and scum from flows prior to physical, biological, or physical treatment processes to improve treatability. Pretreatment may include screening, grit removal, settling, oil/water separation, or application of a Basic Treatment BMP prior to infiltration.</p>
<b>Priority peat systems</b>	<p>Unique, irreplaceable fens that can exhibit water pH in a wide range from highly acidic to alkaline, including fens typified by Sphagnum species, <u>Ledum groenlandicum</u> (Labrador tea), <u>Drosera rotundifolia</u> (sundew), and <u>Vaccinium oxycoccos</u> (bog cranberry); marl fens; estuarine peat deposits; and other moss peat systems with relatively diverse, undisturbed flora and fauna. Bog is the common name for peat systems having the Sphagnum association described, but this term applies strictly only to systems that receive water income from precipitation exclusively.</p>
<b>Professional civil engineer</b>	<p>A person registered with the state of Washington as a professional engineer in civil engineering.</p>

**Project**

Any proposed action to alter or develop a project site. The proposed action of a permit application or an approval which requires drainage review.

Projects can be defined by:

- Common Plans of Development (definition in glossary)
- Land Use Actions, excluding Boundary Line Adjustments (BLAs)
- New development or redevelopment on contiguous or non-contiguous parcels that are permitted under a single permit number or that are part of a subdivision regardless of ownership.
- Other City departmental conditions and review (e.g. offsite improvements are imposed on multiple parcels)

Single Family/Duplex Projects can be defined by:

- Land Use Actions, excluding Boundary Line Adjustments
- New development or redevelopment on contiguous or non-contiguous parcels that are permitted under a single permit number or that are part of a subdivision regardless of ownership.
- Other City departmental conditions and review (e.g. offsite improvements are imposed on multiple parcels)

Land use actions that would affect if a proposed development is a project include, without limitation, plats, short plats, site specific rezones, wetland development permits, conditional use permits, shoreline development permits, and SEPA, if the intent of those land use actions is to develop the affected parcel, parcels or right of way. All other land use permits may create a project depending upon the project scope proposed in the land use action.

Conveyances into different ownership for the ostensible purpose of avoiding more comprehensive stormwater review and requirements, or where an innocent conveyance has this effect, may be considered to be part of a project and reviewed by Environmental Services for cumulative impacts.

The final determination of a project shall be made by Environmental Services

**Project site**

That portion of a property, properties, or right of way subject to land disturbing activities, new hard surfaces, or replaced hard surfaces. On-site and associated off-site improvements shall be added together when determining if a project site exceeds a threshold. Environmental Services shall make the final determination of the project site.

**Properly Functioning Soil System (PFSS)**

Equivalent to engineered soil/landscape system. This can also be a natural system that has not been disturbed or modified.

<b>Puget Sound basin</b>	Puget Sound south of Admiralty Inlet (including Hood Canal and Saratoga Passage); the waters north to the Canadian border, including portions of the Strait of Georgia; the Strait of Juan de Fuca south of the Canadian border; and all the lands draining into these waters as mapped in Water Resources Inventory Areas numbers 1 through 19, set forth in WAC 173-500-040.
<b>Rain Garden</b>	A non-engineered shallow landscaped depression, with compost-amended native soils and adapted plants. The depression is designed to pond and temporarily store stormwater runoff from adjacent areas, and to allow stormwater to pass through the amended soil profile. Refer to the Rain Garden Handbook for Western Washington Homeowners for additional information, <a href="http://raingarden.wsu.edu">http://raingarden.wsu.edu</a>
<b>Rare, threatened, or endangered species</b>	Plant or animal species that are regional relatively uncommon, are nearing endangered status, or whose existence is in immediate jeopardy and is usually restricted to highly specific habitats. Threatened and endangered species are officially listed by federal and state authorities, whereas rare species are unofficial species of concern that fit the above definitions.
<b>Rational method</b>	A means of computing storm drainage flow rates (Q) by use of the formula $Q = CIA$ , where $C$ is a coefficient describing the physical drainage area, $I$ is the rainfall intensity and $A$ is the area.
<b>Reach</b>	A length of channel with uniform characteristics.
<b>Receiving waterbody or Receiving waters</b>	Naturally and/or reconstructed naturally occurring surface waterbodies, such as creeks, streams, rivers, lakes, wetlands, estuaries, and marine waters, or groundwater, to which a MS4 discharges.
<b>Recharge</b>	The addition of water to the zone of saturation (i.e., an aquifer).
<b>Recommended BMPs</b>	As used in Volume 4, recommended BMPs are those BMPs that are not expected to be mandatory by local governments at new development and redevelopment sites. However, they may improve pollutant control efficiency, and may provide a more comprehensive and environmentally effective stormwater management program.

<b>Redevelopment</b>	<p>On a site that is already substantially developed (has 35% or more of existing hard surface coverage - when determining percentage only include those areas that are buildable):</p> <ul style="list-style-type: none"> <li>• The creation or addition of hard surfaces</li> <li>• The expansion of a building footprint or addition or replacement of a structure</li> <li>• Structural development including construction, installation or expansion of a building or other structure</li> <li>• Replacement of hard surface that is not part of a routine maintenance activity</li> <li>• Land disturbing activities</li> </ul>
<b>Regional</b>	An action (here, for stormwater management purposes) that involves more than one discrete property.
<b>Regional stormwater facility</b>	A stormwater facility designed to provide water quality or flow control for a large region or portion of a basin or subbasin.
<b>Release rate</b>	The computed peak rate of surface and stormwater runoff from a site.
<b>Removed impervious surface</b>	Areas where the impervious surface covering (i.e. building, pavement, gravel, etc.) has been removed, the soil has been amended in accordance with the BMP L613 (Volume 3, Section 4.1) and the area is left as a permanent pervious surface (landscaping, natural areas) and planted with native vegetation including evergreen trees. Removed impervious surfaces are not required to be added to the impervious area totals to determine compliance with Minimum Requirements #6, #7 and #8.
<b>Replaced hard surface</b>	<p>For structures, the removal and replacement of hard surfaces down to or including the foundation. For other hard surfaces, the removal down to bare soil or top of base course layer and replacement, including replacement as required for repairing the base course layer.</p> <p>On redevelopment sites, the construction of a structure over an existing asphalt or concrete surface will not be considered new or replaced impervious surfaces and will not count toward project thresholds if the existing underlying asphalt or concrete surface remains in place and undisturbed. See exemptions for Pavement Maintenance, Volume 1, Section 3.2.</p>

<b>Replaced impervious surface</b>	<p>For structures, the removal and replacement of impervious surfaces down to or including the foundation. For other impervious surfaces, the removal down to bare soil or top of base course layer and replacement, including replacement as required for repairing the base course layer.</p> <p>On redevelopment sites, the construction of a structure over an existing asphalt or concrete surface will not be considered new or replaced impervious surfaces and will not count toward project thresholds if the existing underlying asphalt or concrete surface remains in place and undisturbed. See exemptions for Pavement Maintenance, Volume 1, Section 3.2.</p>
<b>Residential</b>	Single family residences, duplexes and triplexes.
<b>Residential density</b>	The number of dwelling units per unit of surface area. Net density includes only occupied land. Gross density includes unoccupied portions of residential areas, such as roads and open space.
<b>Restoration (wetland)</b>	Actions performed to reestablish wetland functional characteristics and processes that have been lost by alterations, activities, or catastrophic events in an area that no longer meets the definition of a wetland.
<b>Resurfacing</b>	Also known as a grind and overlay where the existing asphalt or concrete surface is milled or ground down to remove the damaged surface. An asphalt or concrete overlay is then placed. If material must be removed to the top of the base course layer, the activity is considered replacement of a hard surface and subject to the Minimum Requirements as applicable for replaced surfaces.
<b>Retention</b>	The process of collecting and holding surface and stormwater runoff with no surface outflow.
<b>Retention/detention facility (R/D)</b>	A type of drainage facility designed either to hold water for a considerable length of time and then release it by evaporation, plant transpiration, and/or infiltration into the ground; or to hold surface and stormwater runoff for a short period of time and then release it to the surface and stormwater management system.
<b>Retrofitting</b>	The renovation of an existing structure or facility to meet changed conditions or to improve performance.
<b>Return frequency</b>	A statistical term for the average time of expected interval that an event of some kind will equal or exceed given conditions (e.g., a stormwater flow that occurs every 2 years)
<b>Rhizome</b>	A modified plant stem that grows horizontally underground.



<b>Riffles</b>	Fast sections of a stream where shallow water races over stones and gravel. Riffles usually support a wider variety of bottom organisms than other stream sections.
<b>Rill</b>	A small intermittent watercourse with steep sides, usually only a few inches deep. Often rills are caused by an increase in surface water flow when soil is cleared of vegetation.
<b>Riprap</b>	A facing layer or protective mound of rocks placed to prevent erosion or sloughing of a structure or embankment due to flow of surface and stormwater runoff.
<b>Riparian</b>	Pertaining to the banks of streams, wetlands, lakes, or tidewater.
<b>Riser</b>	A vertical pipe extending from the bottom of a pond BMP that is used to control the discharge rate from a BMP for a specified design storm.
<b>Road Related Project</b>	A project whose objective is the construction or maintenance of elements within the roadway section or right-of-way including the driving surface, sidewalks, bike paths, and pedestrian paths. Sidewalks, bike paths, and pedestrian paths must be associated with an abutting or adjacent driving surface. Roadway elements built as a requirement for onsite actions and permit issuance are not included in this category.
<b>Road Prism</b>	The area containing the road surface (including shoulders and curbs), cut slope and fill slope.
<b>Rodenticide</b>	A substance used to destroy rodents.
<b>Runoff</b>	Water originating from rainfall and other precipitation that is found in drainage facilities, rivers, streams, springs, seeps, ponds, lakes and wetlands as well as shallow groundwater. As applied in this manual, it also means the portion of rainfall or other precipitation that becomes surface flow and interflow.
<b>SCS</b>	Soil Conservation Service (now the Natural Resources Conservation Service), U.S. Department of Agriculture
<b>SCS Method</b>	A single-event hydrologic analysis technique for estimating runoff based on the Curve Number method. The Curve Numbers are published by NRCS <i>in Urban Hydrology for Small Watersheds, 55 TR, June 1976</i> . With the change in name to the Natural Resource Conservation Service, the method may be referred to as the NRCS Method.
<b>Salmonid</b>	A member of the fish family <u>Salmonidae</u> . Chinook, coho, chum, sockeye and pink salmon; cutthroat, brook, brown, rainbow, and steelhead trout; Dolly Varden, kokanee, and char are examples of salmonid species.

<b>Sand filter</b>	A man-made depression or basin with a layer of sand or a sand layer within another facility that treats stormwater as it percolates through the sand and is discharged via a central collector pipe or allowed to infiltrate into the native soil.
<b>Saturation point</b>	In soils, the point at which a soil or an aquifer will no longer absorb any amount of water without losing an equal amount.
<b>Scour</b>	Erosion of channel banks due to excessive velocity of the flow of surface and stormwater runoff.
<b>Sediment</b>	Fragmented material that originates from weathering and erosion of rocks or unconsolidated deposits, and is transported by, suspended in, or deposited by water.
<b>Sedimentation</b>	The depositing or formation of sediment.
<b>Sensitive emergent vegetation communities</b>	Assemblages of erect, rooted, herbaceous vegetation, excluding mosses and lichens, at least some of whose members have relatively narrow ranges of environmental requirements, such as hydroperiod, nutrition, temperature, and light. Examples include fen species such as sundew and, as well as a number of species of Carex (sedges).
<b>Sensitive life stages</b>	Stages during which organisms have limited mobility or alternatives in securing the necessities of life, especially including reproduction, rearing, and migration periods.
<b>Sensitive scrub-shrub vegetation communities</b>	Assemblages of woody vegetation less than 6 meters in height, at least some of whose members have relatively narrow ranges of environmental requirements, such as hydroperiod, nutrition, temperature, and light. Examples include fen species such as Labrador tea, bog laurel, and cranberry.
<b>Settleable solids</b>	Those suspended solids in stormwater that separate by settling when the stormwater is held in a quiescent condition for a specified time.
<b>Sheet erosion</b>	The relatively uniform removal of soil from an area without the development of conspicuous water channels.
<b>Sheet flow</b>	Runoff that flows over the ground surface as a thin, even layer, not concentrated in a channel.
<b>Shoreline development</b>	The proposed project as regulated by the Shoreline Management Act. Usually the construction over water or within a shoreline zone (generally 200 feet landward of the water) of structures such as buildings, piers, bulkheads, and breakwaters, including environmental alterations such as dredging and filling, or any project which interferes with public navigational rights on the surface waters.
<b>Short circuiting</b>	The passage of runoff through a BMP in less than the design treatment time.

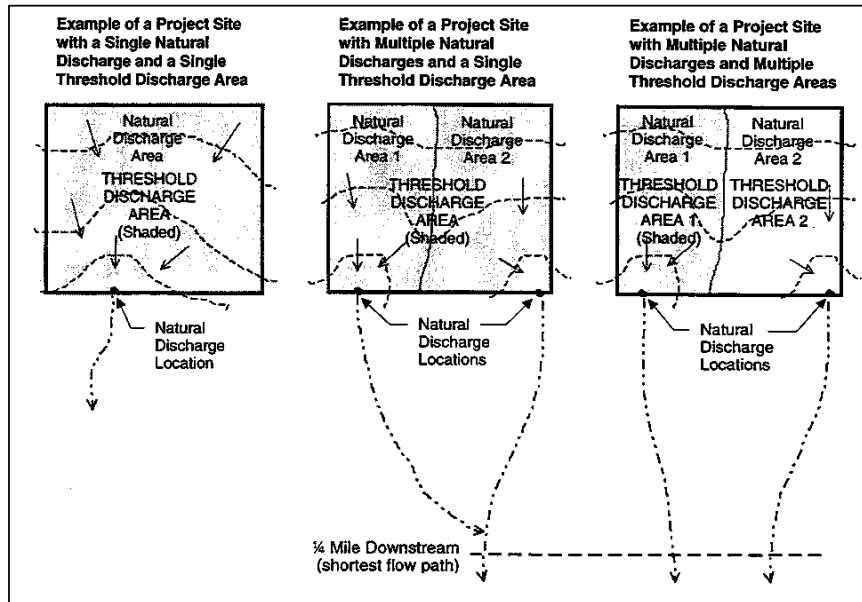
<b>Siltation</b>	The process by which a river, lake, or other waterbody becomes clogged with sediment. Silt can clog gravel beds and prevent successful salmon spawning.
<b>Site</b>	The legal boundaries of a parcel or parcels of land that is (are) subject to new development or redevelopment. For road projects, the length of the project site and the right-of-way boundaries define the site.
<b>Slope</b>	Degree of deviation of a surface from the horizontal; measured as a numerical ratio, percent, or in degrees. Expressed as a ratio, the first number is the horizontal distance (run) and the second is the vertical distance (rise), as 2:1. A 2:1 slope is a 50 percent slope. Expressed in degrees, the slope is the angle from the horizontal plane, with a 90° slope being vertical (maximum) and 45° being a 1:1 or 100 percent slope.
<b>Sloughing</b>	The sliding of overlying material. It is the same effect as caving, but it usually occurs when the bank or an underlying stratum is saturated or scoured.
<b>Soil</b>	The unconsolidated mineral and organic material on the immediate surface of the earth that serves as a natural medium for the growth of land plants. See also topsoil, engineered soil/landscape system, and properly functioning soil system.
<b>Soil group, hydrologic</b>	A classification of soils by the Soil Conservation Service into four runoff potential groups. The groups range from A soils, which are very permeable and produce little or no runoff, to D soils, which are not very permeable and produce much more runoff.
<b>Soil horizon</b>	A layer of soil, approximately parallel to the surface, which has distinct characteristics produced by soil-forming factors.
<b>Soil profile</b>	A vertical section of the soil from the surface through all horizons, including C horizons.
<b>Soil structure</b>	The relation of particles or groups of particles which impart to the whole soil a characteristic manner of breaking; some types are crumb structure, block structure, platy structure, and columnar structure.
<b>Soil permeability</b>	The ease with which gases, liquids, or plant roots penetrate or pass through a layer of soil.
<b>Soil stabilization</b>	The use of measures such as rock lining, vegetation or other engineering structures to prevent the movement of soil when loads are applied to the soil.

<b>Soil Texture Class</b>	The relative proportion, by weight, of particle sizes, based on the USDA system, of individual soil grains less than 2 mm equivalent diameter in a mass of soil. The basic texture classes in the approximate order of increasing proportions of fine particles include: sand, loamy sand, sandy loam, loam, silt loam, silt, clay loam, sandy clay, silty clay, and clay.
<b>Sorption</b>	The physical or chemical binding of pollutants to sediment or organic particles.
<b>Source control BMP</b>	A structure or operation that is intended to prevent pollutants from coming into contact with stormwater through physical separation of areas or careful management of activities that are sources of pollutants. This manual separates source control BMPs into two types. <i>Structural source control BMPs</i> are physical, structural, or mechanical devices or facilities that are intended to prevent pollutants from entering stormwater. <i>Operational BMPs</i> are non-structural practices that prevent or reduce pollutants from entering stormwater. See Volume 4 for details.
<b>Spill control device</b>	A Tee section or turn down elbow designed to retain a limited volume of pollutant that floats on water, such as oil or antifreeze. Spill control devices are passive and must be cleaned-out for the spilled pollutant to actually be removed.
<b>Spillway</b>	A passage such as a paved or otherwise stabilized apron or channel for surplus water over or around a dam or similar obstruction. An open or closed channel, or both, used to convey excess water from a reservoir. It may contain gates, either manually or automatically controlled, to regulate the discharge of excess water.
<b>State Environmental Policy Act (SEPA) RCW 43.21C</b>	The Washington State law intended to minimize environmental damage. SEPA requires that state agencies and local governments consider environmental factors when making decisions on activities, such as development proposals over a certain size and comprehensive plans. As part of this process, environmental documents are prepared and opportunities for public comment are provided.

<b>Steep slope</b>	<p>Slopes of 40 percent gradient or steeper within a vertical elevation change of at least ten feet. A slope is delineated by establishing its toe and top, and is measured by averaging the inclination over at least ten feet of vertical relief. For the purpose of this definition:</p> <p>The toe of a slope is a distinct topographic break in slope that separates slopes inclined at less than 40% from slopes 40% or steeper. Where no distinct break exists, the toe of a steep slope is the lower-most limit of the area where the ground surface drops ten feet or more vertically within a horizontal distance of 25 feet; AND</p> <p>The top of a slope is a distinct topographic break in slope that separates slopes inclined at less than 40% from slopes 40% or steeper. Where no distinct break exists, the top of a steep slope is the upper-most limit of the area where the ground surface drops ten feet or more vertically within a horizontal distance of 25 feet.</p>
<b>Storage routing</b>	A method to account for the attenuation of peak flows passing through a detention facility or other storage feature.
<b>Storm drains</b>	The enclosed conduits that transport surface and stormwater runoff toward points of discharge (sometimes called storm sewers).
<b>Storm drain system</b>	Refers to the system of gutters, pipes, streams, or ditches used to carry surface and stormwater from surrounding lands to streams, lakes, or Puget Sound.
<b>Storm frequency</b>	The time interval between major storms of predetermined intensity and volumes of runoff for which storm sewers and other structures are designed and constructed to handle hydraulically without surcharging and backflooding, e.g., a 2-year, 10-year or 100-year storm.
<b>Storm sewer</b>	A conveyance system that carries stormwater and surface water, street wash and other wash waters or drainage, but excludes sewage and industrial wastes. Also called a storm drain.
<b>Stormwater</b>	That portion of precipitation, including snowmelt, that does not naturally percolate into the ground or evaporate, but flows via overland flow, interflow, pipes and other features of a stormwater drainage system into a receiving water or stormwater facility.
<b>Stormwater drainage system</b>	Constructed and natural features which function together as a system to collect, convey, channel, hold, inhibit, retain, detain, infiltrate, divert, treat or filter stormwater.

<b>Stormwater facility</b>	A component of the stormwater system constructed to perform a particular function such as onsite stormwater management, water quality treatment, flow control, or conveyance.
<b>Stormwater Management Manual for Western Washington (Stormwater Manual)</b>	The manual prepared by Ecology which contains BMPs to prevent, control or treat pollution in stormwater and reduce other stormwater-related impacts to waters of the State. The Stormwater Manual is intended to provide guidance on measures necessary in western Washington to control the quantity and quality of stormwater runoff from new development and redevelopment. This manual is equivalent to the Ecology manual and must be used for projects located within the City of Tacoma.
<b>Stormwater Site Plan (SSP)</b>	A comprehensive report and drawing set containing all the technical information and analysis necessary to evaluate projects for compliance with the stormwater requirements.
<b>Stream gauging</b>	The quantitative determination of stream flow using gages, current meters, weirs, or other measuring instruments at selected locations. See Gauging station.
<b>Streambanks</b>	The usual boundaries, not the flood boundaries, of a stream channel. Right and left banks are named facing downstream.
<b>Streams</b>	Those areas where surface waters flow sufficiently to produce a defined channel or bed. Lands and waters contained within a channel which supports hydrophytes and where the substrate is predominantly undrained hydric soils, nonsoil and/or is saturated with water or covered by water each growing season. The channel or bed need not contain water year-round. This definition is not meant to include irrigation ditches, canals, stormwater runoff devices or other entirely artificial watercourses unless they are used to convey streams naturally occurring prior to construction. Those topographic features that resemble streams but have no defined channels (i.e. swales) shall be considered streams when hydrologic and hydraulic analyses done pursuant to a development proposal predict formation of a defined channel after development.
<b>Structure</b>	Any manmade item. Examples include catch basins, manholes, buildings, decks, etc.
<b>Structural source control BMPs</b>	Physical, structural, or mechanical devices or facilities that are intended to prevent pollutants from entering stormwater. Structural source control BMPs typically include: <ul style="list-style-type: none"> <li>• Enclosing and/or covering the pollutant source (building or other enclosure, a roof over storage and working areas, temporary tarp, etc.).</li> <li>• Segregating the pollutant source to prevent run-on of stormwater, and to direct only contaminated stormwater to appropriate treatment BMPs.</li> </ul>

<b>Stub-out</b>	A short length of pipe provided for future connection to a storm drainage system.
<b>Subbasin</b>	A drainage area that drains to a water-course or waterbody named and noted on common maps and which is contained within a basin.
<b>Subcatchment</b>	A subdivision of a drainage basin (generally determined by topography and pipe network configuration).
<b>Subdrain</b>	A pervious backfilled trench containing stone or a pipe for intercepting groundwater or seepage.
<b>Subgrade</b>	A layer of stone or soil used as the underlying base for a BMP or other facility.
<b>Subsoil</b>	The B horizons of soils with distinct profiles. In soils with weak profile development, the subsoil can be defined as the soil below the plowed soil (or its equivalent of surface soil), in which roots normally grow. Although a common term, it cannot be defined accurately. It has been carried over from early days when "soil" was conceived only as the plowed soil and that under it as the "subsoil."
<b>Substrate</b>	The natural soil base underlying a BMP.
<b>Surcharge</b>	The flow condition occurring in closed conduits when the hydraulic grade line is above the crown of the sewer.
<b>Suspended solids</b>	Organic or inorganic particles that are suspended in and carried by the water. The term includes sand, mud, and clay particles (and associated pollutants) as well as solids in stormwater.
<b>Swale</b>	A shallow drainage conveyance with relatively gentle side slopes, generally with flow depths less than one foot.
<b>TMC</b>	Tacoma Municipal Code
<b>Terrace</b>	An embankment or combination of an embankment and channel across a slope to control erosion by diverting or storing surface runoff instead of permitting it to flow uninterrupted down the slope.
<b>Threshold Discharge Area</b>	<p>An onsite area draining to a single natural or constructed discharge location or multiple natural or constructed discharge locations that converge within one-quarter mile downstream (as determined by the shortest flowpath). The examples in Figure G - 1 illustrate this definition.</p> <p>The purpose of this definition is to clarify how the thresholds of this manual are applied to project sites with multiple discharge points.</p>



**Figure G - 1. Threshold Discharge Area**

<b>Tightline</b>	A continuous length of pipe that conveys water from one point to another (typically down a steep slope) with no inlets or collection points in between.
<b>Tile, Drain</b>	Pipe made of burned clay, concrete, or similar material, in short lengths, usually laid with open joints to collect and carry excess water from the soil.
<b>Tile drainage</b>	Land drainage by means of a series of tile lines laid at a specified depth and grade.
<b>Till</b>	A layer of poorly sorted soil deposited by glacial action that generally has very low infiltration rates.
<b>Time of concentration</b>	The time period necessary for surface runoff to reach the outlet of a subbasin from the hydraulically most remote point in the tributary drainage area.
<b>Topography</b>	General term to include characteristics of the ground surface such as plains, hills, mountains, degree of relief, steepness of slopes, and other physiographic features.
<b>Topsoil</b>	The upper portion of a soil, usually dark colored and rich in organic material. It is more or less equivalent to the upper portion of an A horizon in an ABC soil.
<b>Total dissolved solids</b>	The dissolved salt loading in surface and subsurface waters.



<b>Total Petroleum Hydrocarbons (TPH)</b>	<p>A large family of chemical compounds that come from crude oil. Two types important to stormwater include:</p> <ul style="list-style-type: none"> <li>• TPH-Gx: The qualitative and quantitative method (extended) for volatile (“gasoline”) petroleum products in water; and</li> <li>• TPH-Dx: The qualitative and quantitative method (extended) for semi-volatile (“diesel”) petroleum products in water.</li> </ul>
<b>Total solids</b>	<p>The solids in water, sewage, or other liquids, including the dissolved, filterable, and nonfilterable solids. The residue left when the moisture is evaporated and the remainder is dried at a specified temperature, usually 130°C.</p>
<b>Total suspended solids</b>	<p>That portion of the solids carried by stormwater that can be captured on a standard glass filter.</p>
<b>Total Maximum Daily Load (TMDL) – Water Cleanup Plan</b>	<p>A calculation of the maximum amount of a pollutant that a waterbody can receive and still meet water quality standards, and an allocation of that amount to the pollutant’s sources. A TMDL (also known as a Water Cleanup Plan) is the sum of the allowable loads of a single pollutant from all contributing point and nonpoint sources. The calculation must include a margin of safety to ensure that the waterbody can be used for the purposes the State has designated. The calculation must also account for seasonable variation in water quality. Water quality standards are set by states, territories, and tribes. They identify the uses for each waterbody, for example, drinking water supply, contact recreation (swimming), and aquatic like support (fishing), and the scientific criteria to support that use. The Clean Water Act, Section 303, establishes the water quality standards and TMDL programs.</p>
<b>Toxic</b>	<p>Poisonous, carcinogenic, or otherwise directly harmful to life.</p>
<b>Tract</b>	<p>A legally created parcel of property designated for special nonresidential and noncommercial uses.</p>
<b>Transplanting</b>	<p>The process of relocating and planting an existing plant into a landscape. Note: Trees are considered plants.</p>
<b>Trash rack</b>	<p>A structural device used to prevent debris from entering a spillway or other hydraulic structure.</p>
<b>Travel time</b>	<p>The estimated time for surface water to flow between two points of interest.</p>
<b>Treatment BMP</b>	<p>A BMP that is intended to remove pollutants from stormwater.</p>
<b>Treatment liner</b>	<p>A layer of soil that is designed to slow the rate of infiltration and provide sufficient pollutant removal so as to protect groundwater quality.</p>

<b>Treatment train</b>	A combination of two or more treatment facilities connected in series.
<b>Trunk main</b>	Public stormwater drainage pipes equal to or greater than 36 inches and installed at a minimum slope of 0.5%. Some 36-inch mains may be installed at less than the minimum slope. These shall not be considered trunk mains.
<b>Turbidity</b>	Dispersion or scattering of light in a liquid, caused by suspended solids and other factors; commonly used as a measure of suspended solids in a liquid.
<b>Uncultivated vegetation</b>	Vegetation, including but not limited to, all annuals, woody and herbaceous perennials such as shrubs, vines or trees that are not regularly or systematically maintained through any combination of the following: pruning, mowing, watering, trimming, fertilizing and any other activity intended to ensure public safety and assist vegetation to achieve full environmental and landscape function.
<b>Underdrain</b>	Plastic pipes with holes drilled through the top, installed on the bottom of an infiltration BMP, which are used to collect and remove excess runoff.
<b>Underground utilities</b>	Underground lines which serve the public with various utilities. They are typically located in trenches. Dry utilities include such lines as telephone, cable, electric and gas lines. Wet utilities include storm lines, fire lines, domestic water lines and sewer lines.
<b>Underground utility projects</b>	Those projects with the main objective of repairing, replacing, upsizing, or installing underground utilities. Projects that repair, replace, upsize or install utilities as part of requirements for new or redevelopment are not considered underground utility projects.
<b>Undisturbed buffer</b>	A zone where development activity shall not occur, including logging, and/or the construction of utility trenches, roads, and/or surface and stormwater facilities.
<b>Undisturbed low gradient uplands</b>	Forested land, sufficiently large and flat to infiltrate surface and storm runoff without allowing the concentration of water on the surface of the ground.
<b>Unstable slopes</b>	Those sloping areas of land which have in the past exhibited, are currently exhibiting, or will likely in the future exhibit, mass movement of earth.
<b>Unusual biological community types</b>	Assemblages of interacting organisms that are relatively uncommon regionally.

<b>Urbanized area</b>	Areas designated and identified by the U.S. Bureau of Census according to the following criteria: an incorporated place and densely settled surrounding area that together have a maximum population of 50,000.
<b>U.S. EPA</b>	The United States Environmental Protection Agency.
<b>Values (wetland)</b>	Wetland processes or attributes that are valuable or beneficial to society (also see Functions). Wetland values include support of commercial and sport fish and wildlife species, protection of life and property from flooding, recreation, education, and aesthetic enhancement of human communities.
<b>Variance</b>	See Exception.
<b>Vegetated flowpath</b>	A route with established vegetation measured from the downspout or dispersion system discharge point to the downstream property line, stream, wetland or other impervious surface. The vegetated flowpath shall be measured perpendicular to site contours. For flow credits, this path must contain undisturbed native landscape or lawn landscape installed in soils meeting BMP L613: Post Construction Soil Quality and Depth.
<b>Vegetated roof</b>	A vegetated rooftop, also known as a green roof, is a rooftop that is partially or completely covered with vegetation and a growing medium planted over a waterproofing membrane. The green roof will also contain a root repelling membrane and drainage system.
<b>Vegetation</b>	As related to applicability of the Minimum Requirements, vegetation shall mean native vegetation, pasture, scrub/shrub, uncultivated vegetation, or unmaintained non-native vegetation (e.g., Himalayan blackberries, scotch broom).
<b>Vegetation Maintenance</b>	As related to pavement maintenance, vegetation maintenance includes caring for and controlling vegetation along roadways or paved surfaces to ensure vegetation does not damage the pavement surface or cause a safety concern. Vegetation maintenance may also include moss control and care and control of vegetation that is part of a permeable paver system.

<b>Vehicular Use</b>	<p>Regular use of an impervious or pervious surface by motor vehicles. The following are subject to regular vehicular use:</p> <ul style="list-style-type: none"> <li>• roads;</li> <li>• unvegetated road shoulders;</li> <li>• bike lanes within the traveled lane of a roadway, driveways, parking lots, unrestricted access fire lanes, vehicular equipment storage yards, airport runways, and railroad tracks.</li> </ul> <p>The following are not considered subject to regular vehicular use:</p> <ul style="list-style-type: none"> <li>• paved bike pathways separated from and not subject to drainage from roads for motor vehicles;</li> <li>• restricted access fire lanes;</li> <li>• infrequently used maintenance access roads.</li> </ul>
<b>Waterbody</b>	Surface waters including rivers, streams, lakes, marine waters, estuaries, and wetlands.
<b>Water Cleanup Plan</b>	See Total Maximum Daily Load.
<b>Water quality</b>	A term used to describe the chemical, physical, and biological characteristics of water, usually in respect to its suitability for a particular purpose.
<b>Water quality standards</b>	Minimum requirements of purity of water for various uses; for example, water for agricultural use in irrigation systems should not exceed specific levels of sodium bicarbonate, pH, total dissolved salts, etc. In Washington, the Department of Ecology sets water quality standards.
<b>Watershed</b>	A geographic region within which water drains into a particular river, stream, or body of water. Watersheds can be as large as those identified and numbered by the State of Washington Water Resource Inventory Areas (WRIAs) as defined in Chapter 173-500 WAC.
<b>Water table</b>	The upper surface or top of the saturated portion of the soil or bedrock layer, indicates the uppermost extent of groundwater.
<b>Weir</b>	Device for measuring or regulating the flow of water.
<b>Weir notch</b>	The opening in a weir for the passage of water.

<b>Wetlands</b>	Those areas that are inundated or saturated by surface or groundwater at a frequency and duration sufficient to support, and that under normal circumstances do support, a prevalence of vegetation typically adapted for life in saturated soil conditions. Wetlands generally include swamps, marshes, bogs, and similar areas. Wetlands do not include those artificial wetlands intentionally created from nonwetland sites, including, but not limited to, irrigation and drainage ditches, grass-lined swales, canals, stormwater treatment wetlands, detention facilities, wastewater treatment facilities, farm ponds, and landscape amenities, or those wetlands created after July 1, 1990, that were unintentionally created as a result of the construction of a road, street, or highway. Wetlands may include those artificial wetlands intentionally created from nonwetland areas to mitigate the conversion of wetlands. (Waterbodies not included in the definition of wetlands as well as those mentioned in the definition are still waters of the state.)
<b>Wetland edge</b>	Delineation of the wetland edge shall be based on the U.S. Army Corps of Engineers <u>Wetlands Delineation Manual</u> , Technical Report Y-87-1, U.S. Army Engineers Waterways Experiment Station, Vicksburg, Miss. (1987)
<b>Wetponds and wetvaults</b>	Drainage facilities for water quality treatment that contain permanent pools of water that are filled during the initial runoff from a storm event. They are designed to optimize water quality by providing retention time in order to settle out particles of fine sediment to which pollutants such as heavy metals absorb, and to allow biologic activity to occur that metabolizes nutrients and organic pollutants.
<b>WWHM</b>	Western Washington Hydrology Model. An Ecology and City approved continuous simulation model may be used instead of the WWHM. It is the applicant's responsibility to ensure the appropriate time step is used in the analysis.
<b>Zoning ordinance</b>	An ordinance based on the police power of government to protect the public health, safety, and general welfare. It may regulate the type of use and intensity of development of land and structures to the extent necessary for a public purpose. Requirements may vary among various geographically defined areas called zones. Regulations generally cover such items as height and bulk of buildings, density of dwelling units, off-street parking, control of signs, and use of land for residential, commercial, industrial, or agricultural purposes. A zoning ordinance is one of the major methods for implementation of a comprehensive plan.